

TABLE OF CONTENTS

BODY	09-02-1
INSTALLATION AND ADJUSTMENT	09-02-1
HEADLAMP BEAM AIMING	09-02-1
BULB REPLACEMENT	09-02-1
DECAL	09-02-2
WINDSHIELD INSTALLATION	09-02-2
GUARD	09-02-2
WIRING HARNESS	09-02-2
CABLES	09-02-2
TUBING	09-02-2
PLASTIC MAINTENANCE AND REPAIR	09-02-3
MAINTENANCE	09-02-3
REPAIR.....	09-02-4

FRAME	09-03-1
FRAME CLEANING	09-03-1
FRAME WELDING	09-03-1
FRAME COMPONENT REPLACEMENT	09-03-1

BODY

INSTALLATION AND ADJUSTMENT

HEADLAMP BEAM AIMING

Beam aiming is correct when center of high beam is 25 mm (1 in) below the headlamp horizontal center line, scribed on a test surface, 381 cm (12 ft 6 in) away.

Measure headlamp center distance from ground. Scribe a line at this height on test surface (wall or screen). Light beam center should be 25 mm (1 in) below scribed line.

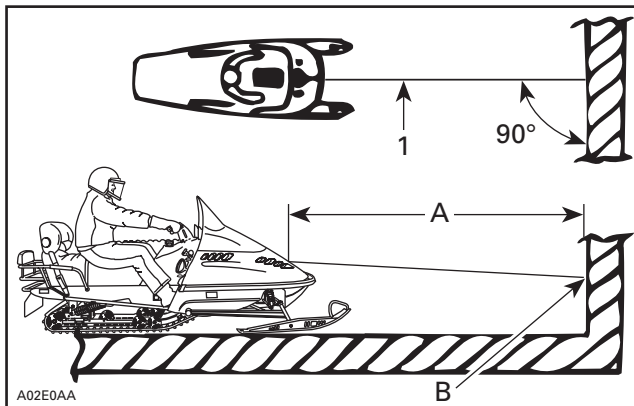

TYPICAL

1. Headlamp center line
- A. 381 cm (12 ft 6 in)
- B. 25 mm (1 in) below center line

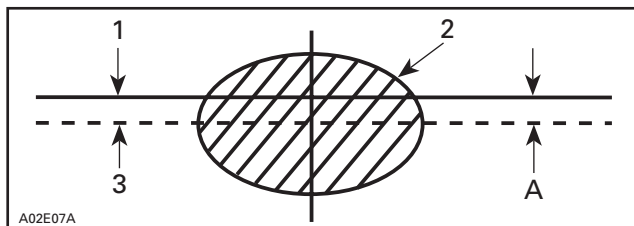

1. Headlamp horizontal
2. Light beam (high beam) (projected on the wall)
3. Light beam center
- A. 25 mm (1 in)

Required Conditions

Place the vehicle on a flat surface perpendicular to test surface (wall or screen) and 381 cm (12 ft 6 in) away from it.

Rider or equivalent weight must be on the vehicle.

Select **high beam**.

BULB REPLACEMENT

Headlamp

If any headlight bulb is burnt, remove windshield. Unplug burnt bulb connector. Remove the rubber boot.

Unfasten bulb retainer ring. Detach the bulb and replace. Properly reinstall parts.

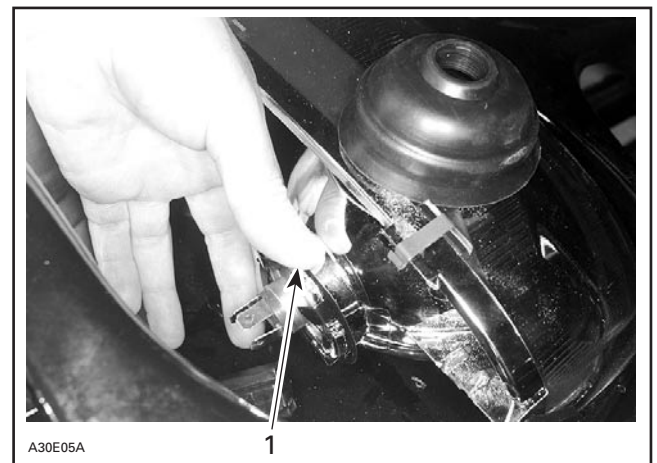

1. Locking ring

CAUTION: Never touch glass portion of an halogen bulb with bare fingers, as it shortens its operating life. If by mistake glass is touched, clean it with isopropyl alcohol which will not leave a film on the bulb.

Taillight

If the taillight bulb is burnt, expose the bulb by removing red plastic lens. To remove, unscrew the 2 retaining screws. Verify all lights after replacement.

Section 09 BODY/FRAME

Subsection 02 (BODY)

DECAL

To remove a decal; heat old decal with a heat gun and peel off slowly.

Using isopropyl alcohol, clean the surface and dry thoroughly.

Apply liquid soap to new decal and carefully position the decal. Using a sponge or a squeegee, remove the air bubbles and surplus water working from the center toward the edges. Allow to air dry.

CAUTION: Do not apply isopropyl alcohol or solvent directly on decals. Use only in a well ventilated area.

WINDSHIELD INSTALLATION

Remove protective film.

Position the windshield on the hood then push it down until the tabs are fully inserted into the hood slots. Lock the windshield tabs in position.

GUARD

Disassembly and Assembly

NOTE: For additional information (ex.: exploded view) refer to the correspondent *Parts Catalog*.

WARNING

Engine should be running only with guard well secured in place.

Inspection

Check guard mounting bosses, clips and retainers for wear.

WIRING HARNESS

WARNING

Ensure all terminals are properly crimped on the wires and that all connector housings are properly fastened. Keep wires away from any rotating, moving, heating and vibrating parts. Use proper fastening devices as required.

CABLES

WARNING

Before installation, ensure that all cables are in perfect condition. Properly install the cable ends and secure them in place. Pay attention to route them properly, away from any rotating, moving, heating or vibrating parts.

TUBING

WARNING

Always ensure that the fuel, vent, primer, impulse, injection oil and rotary valve oil lines are properly fixed to their connectors, that they are not perforated or kinked and that they are properly routed away from any rotating, moving, heating or vibrating parts. Also check for leaks. Replace if required.

NOTE: Refer to proper *Parts Catalog* to find suitable clip part numbers.

PLASTIC MAINTENANCE AND REPAIR

MAINTENANCE

Clean the vehicle thoroughly, removing all dirt and grease accumulation.

To clean use a soft clean cloth and either soapy water or isopropyl alcohol.

To remove grease, oil or glue use isopropyl alcohol.

CAUTION: Do not apply isopropyl alcohol or acetone directly on decals.

CAUTION: The following products must not be used to clean or wax any of the plastic components used on the vehicles:

- gasoline
- brake fluid
- kerosene
- diesel fuel
- lighter fluid
- varsol
- naphtha
- acetone
- strong detergents
- abrasive cleaners
- waxes containing an abrasive or a cleaning agent in their formula.

Apply wax on glossy finish only. Protect the vehicle with a cover to prevent dust accumulation during storage.

CAUTION: If for some reason the snowmobile has to be stored outside, it is preferable to cover it with an opaque tarpaulin. This will prevent the sun rays from affecting the plastic components and the vehicle finish.

Section 09 BODY/FRAME

Subsection 02 (BODY)

REPAIR

The very first step before repairing plastic materials is to find out exactly which type of material is involved. Refer to following chart.

CAUTION: Consult chart below and repair kit instructions carefully, some repair products are not compatible with certain plastics.

WARNING

Polycarbonate windshields must never be repaired by welding or otherwise.

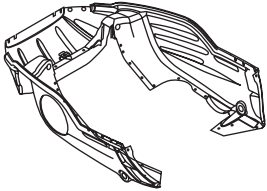
PART	MODEL	REPAIRABLE		
		IMPACT COPOLYMER	R.R.I.M. POLYURETHANE	SURLYN
BOTTOM PAN  A32H344	All ZX series			

For hood repair, refer to a specialized shop.

The following company provides a complete line of products to repair plastic materials:

CREST INDUSTRIES, INC. Trenton, MI 48183	Phone: 734-479-4141 Toll Free: 1-800-822-4100 Fax: 1-800-344-4461 Fax: 734-479-4040 E-Mail: info@crestauto.com www.crestauto.com
---	--

FRAME

FRAME CLEANING

NOTE: For bare aluminum frames use only aluminum cleaner and follow instructions on container. (Dursol cleaner or equivalent).

Clean frame and tunnel with appropriate cleaners and rinse with high pressure hose.

CAUTION: Never direct high-pressure water jet towards decals. They would peel off.

Touch up all metal spots where paint has been scratched off. Spray all bare metal parts of vehicle with metal protector.

Seat Cleaning

For all models, it is recommend to clean the seat with a solution of **warm soapy water**, using a soft clean cloth.

CAUTION: Avoid use of harsh detergents such as strong soaps, degreasing solvents, abrasive cleaners, paint thinners, etc., that may cause damage to the seat cover.

FRAME WELDING

Aluminum Frame

- No welds should be done on aluminum frame except if mentioned or required on a Bombardier bulletin.
- Use ER-5356 rods for MIG or TIG welding.

CAUTION: Before performing electrical welding anywhere on the vehicle, unplug MPEM. On models equipped with a battery, also unplug the negative cable. This will protect the electronic box and battery against damage caused by flowing current when welding.



TYPICAL — MPEM UNPLUGGED

CAUTION: If welding is to be done near plastic material, it is recommended to either remove the part from the area or to protect it with aluminum foil to prevent damage.

FRAME COMPONENT REPLACEMENT

Drilling Procedure

When drilling self-piercing rivets, use Supertanium™ drill bit (P/N 529 031 800), available in a 5 mm (3/16 in) size and shipped in packs of 2.

For proper drilling instructions and to prevent premature wear, follow the procedure below.

Always use a variable speed electric drill.

Partially drill rivet end — not the rivet head.

Maintain a slow to medium speed at all times when drilling. The proper speed is attained when a constant chip is ejected.

NOTE: To increase bit life, use Bombardier synthetic chaincase oil (P/N 413 803 300) as a cutting oil.

CAUTION: High speed drilling will cause excessive heat which may destroy the cutting edge of the bit; therefore, avoid using pneumatic drills.



Cut rivet using a chisel.

Remove riveted part.

Drive out remaining rivet head using a punch.