

WIRING DIAGRAMS

Wiring diagrams can be found at the end of this subsection.

WIRING DIAGRAM LEGEND

⚠ WARNING

Ensure all terminals are properly crimped on the wires and all connector housings are properly fastened.

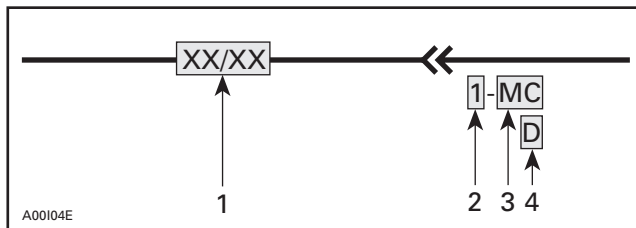

1. Wire colors
2. Connector housing area
3. Housing code per area
4. Wire connector location in housing

WIRE COLORS

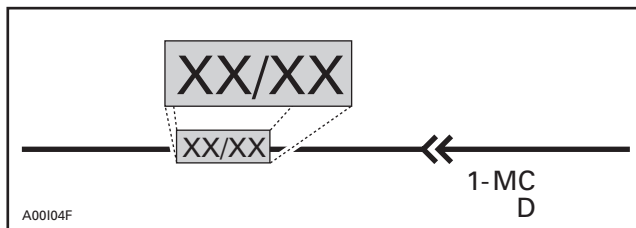

The first color of a wire is the main color, second color is the stripe.

Example: YL/BK is a YELLOW wire with a BLACK stripe.

COLOR CODE					
BE	-	BEIGE	OR	-	ORANGE
BK	-	BLACK	RD	-	RED
BU	-	BLUE	VI	-	VIOLET
BR	-	BROWN	WH	-	WHITE
GN	-	GREEN	YL	-	YELLOW
GY	-	GREY			

CONNECTOR HOUSING AREA

The first digit of the connector identification number presents the location of the connector on the vehicle.

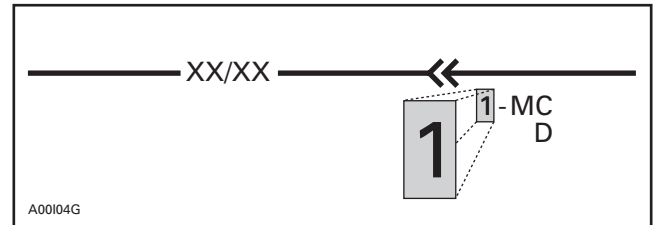

The following illustration shows the snowmobile with number on it. These numbers will correspond with the locations of the connector on the vehicle along with a brief description.

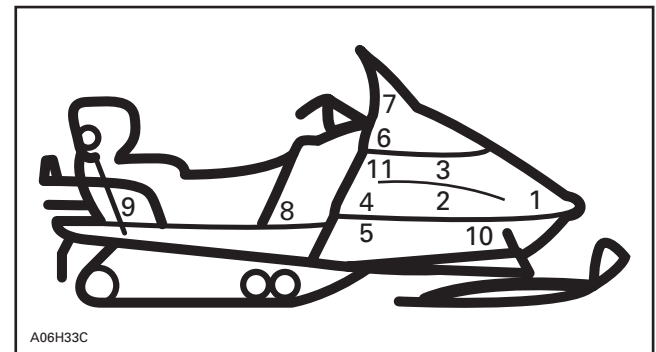

AREA	LOCATION
1	Front of engine compartment
2	Magneto
3	Carburetors
4	Near intake silencer
5	Near driven pulley
6	Under console
7	Under hood
8	Near fuel tank
9	Rear of seat
10	Under engine
11	On injection oil reservoir

Section 11 WIRING DIAGRAMS

Subsection 01 (WIRING DIAGRAMS)

HOUSING REFERENCE PER AREA

The next two letters of the connector identification number represents a connector reference. If there are many connectors in the same area this helps identify which wire is in which connector.

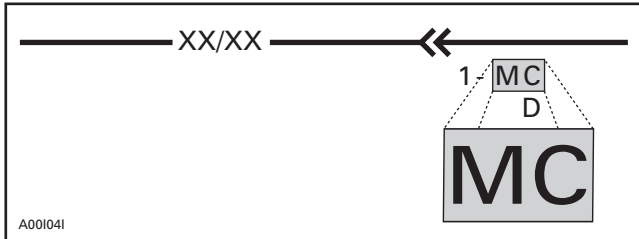

WIRE LOCATION IN CONNECTOR HOUSING

The third portion of the connector identification number represents the location of the wire in the connector housing. This could be identified by either a number such as 1, 2, 3 or by a letter such as A, B, C depending on the type of connector used.

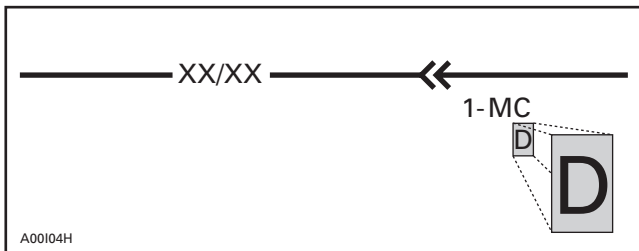

Section 11 WIRING DIAGRAMS



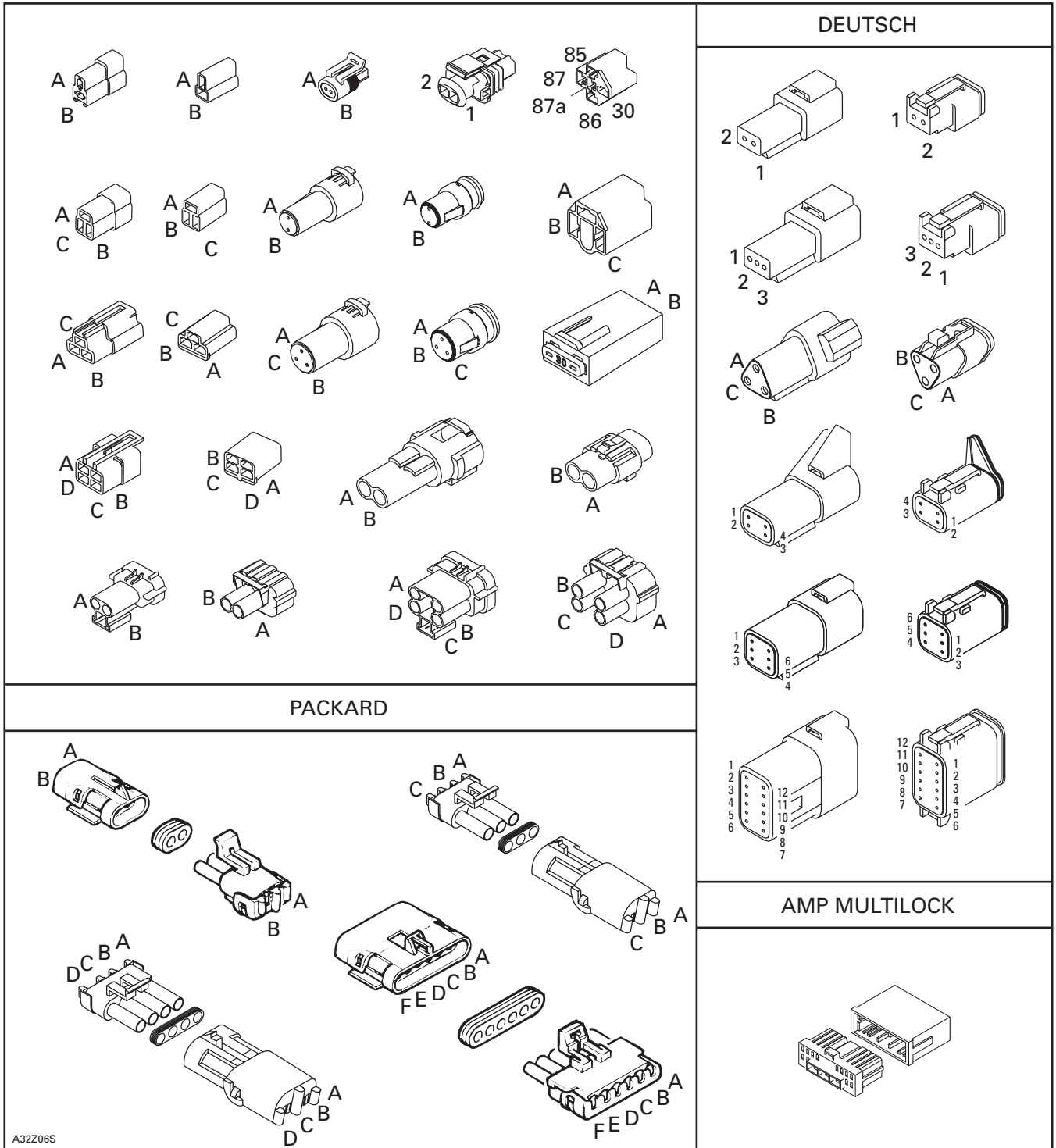







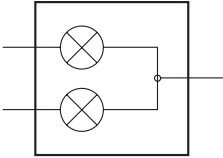
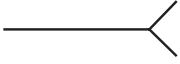
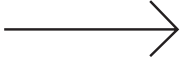

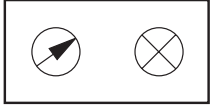

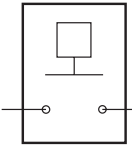
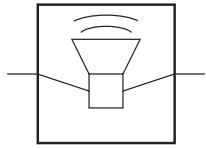

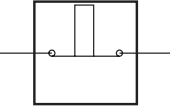
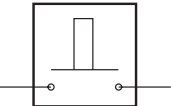

Subsection 01 (WIRING DIAGRAMS)

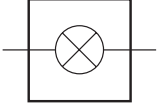
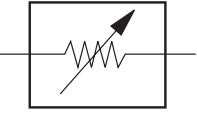
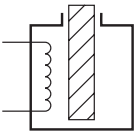

A32Z06S

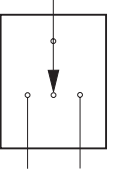
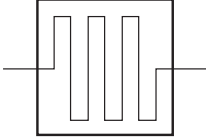
Section 11 WIRING DIAGRAMS
 Subsection 01 (WIRING DIAGRAMS)

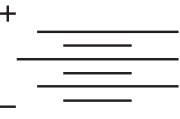
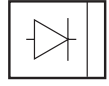
SYMBOLS DESCRIPTION

<p>Beam and tail light</p> 	<p>Female terminal</p> 	<p>Male terminal</p> 	<p>Electronic module</p> 
<p>Meter</p> 	<p>Electric motor</p> 	<p>Low level sensor</p> 	<p>Buzzer</p> 
<p>Ignition coil</p> 	<p>Normally close switch</p> 	<p>Normally open switch</p> 	<p>Male terminal on instrument</p> 
<p>Engine ground</p> 	<p>Frame ground</p> 	<p>Spark plug</p> 	<p>Meter movement</p> 
<p>Bulb</p> 	<p>Pilot</p> 	<p>Analog sensor</p> 	<p>Solenoid valve</p> 
<p>Magneto (Delta)</p> 	<p>3 position switch</p> 	<p>Heating element</p> 	<p>Fuse</p> 
<p>Trigger coil</p> 	<p>Battery</p> 	<p>Diode</p> 	<p>Partially illustrated component</p> 

A00E9PS

UNPLUGGING CONNECTORS

Always unplug connectors by pulling on housing not on wire.

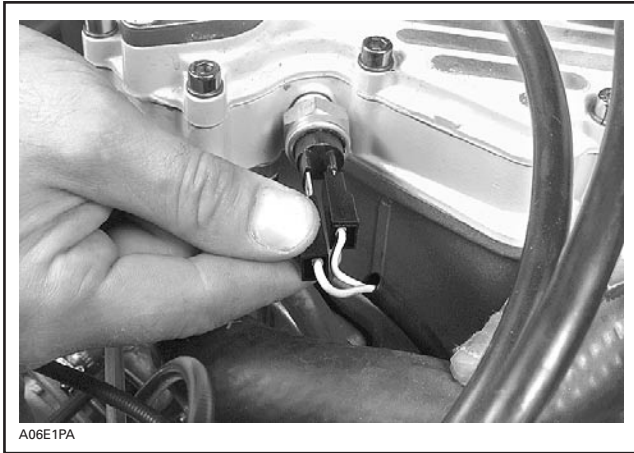

TYPICAL

TAB AND RECEPTACLE CONNECTORS REMOVAL

Tab Connector

It is locked in its housing by a spring tab on its side. Removal is done by squeezing this tab.

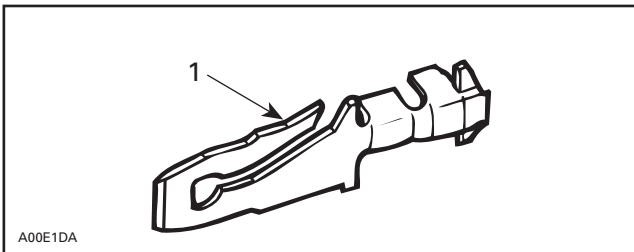

TAB CONNECTOR

1. Locking tab

To remove:

- Insert a screwdriver or Snap-on TT 600-5 from opposite side of wire and pry locking tab.
- While holding locking tab pried, pull connector toward wire side.

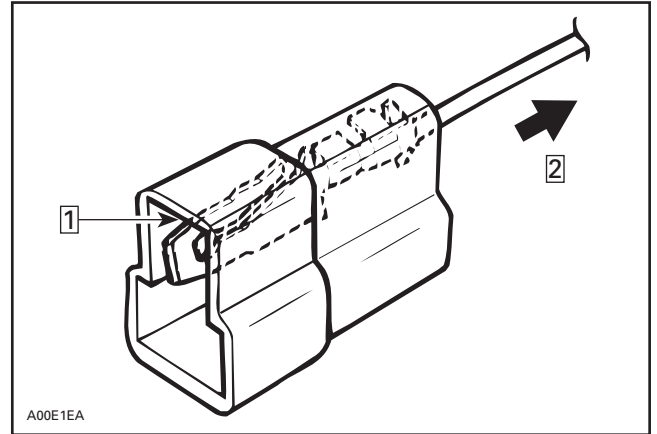

Step 1: Insert screwdriver here

Step 2: Pull this side

Locking Receptacle Connector

To remove:

- Insert tool Snap-on TT 600-5 in access opening then pull housing toward wire side.

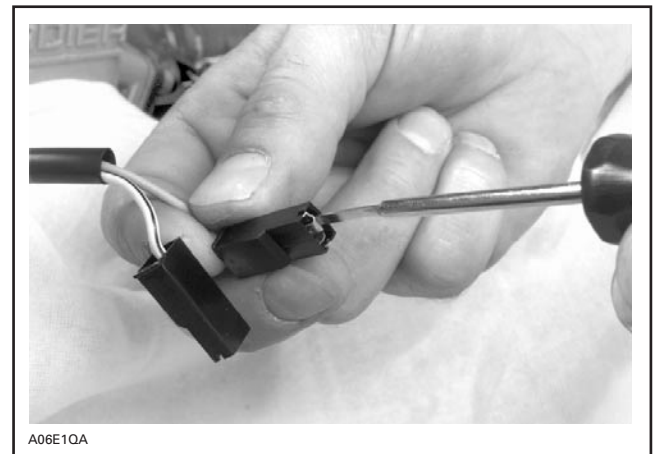

Section 11 WIRING DIAGRAMS

Subsection 01 (WIRING DIAGRAMS)

Waterproof Connector Housing

Female Connector Housing

To remove:

- Insert tool Snap-on TT 600-5 under lock and twist to lift it.

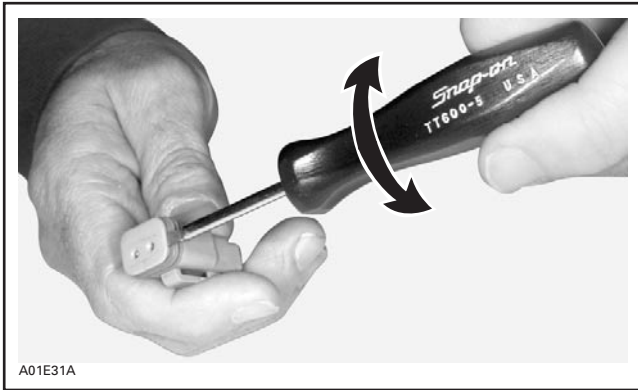

- Pry tab to free connector then pull wire out of housing.

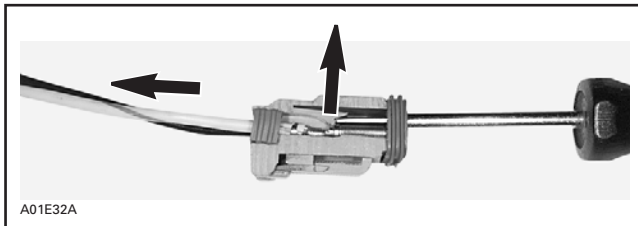

FEMALE CONNECTOR HOUSING — CUT-AWAY

Male Connector Housing

To remove:

- Using a small hook, pull out the lock.

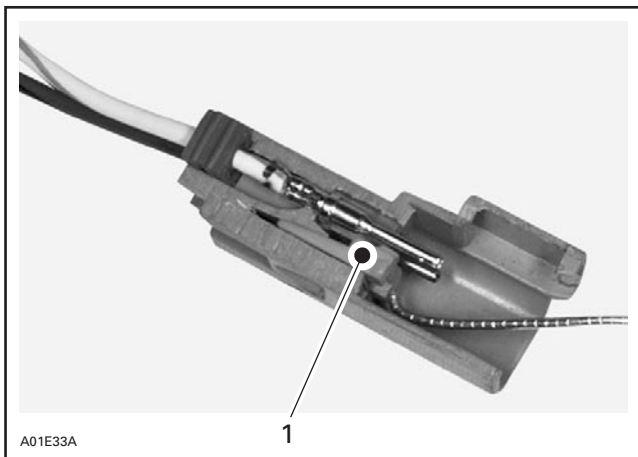

1. Lock

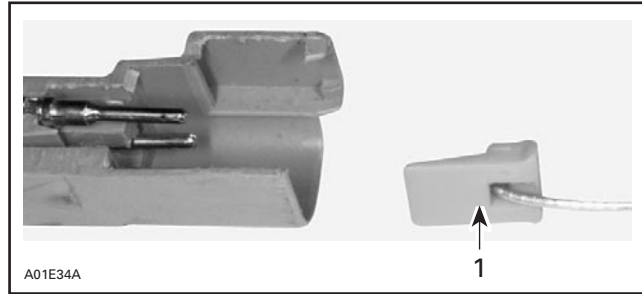

1. Lock

- Pry tab to free connector then pull wire out of housing.

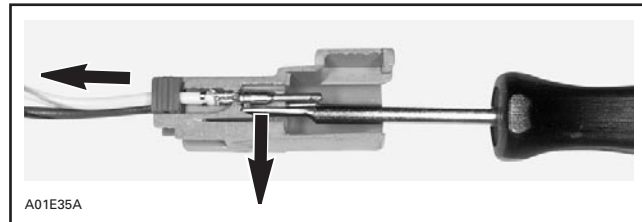

MALE CONNECTOR HOUSING — CUT-AWAY

Round Connector Housing

Female Connector Housing



Section 11 WIRING DIAGRAMS
Subsection 01 (WIRING DIAGRAMS)

Male Connector Housing

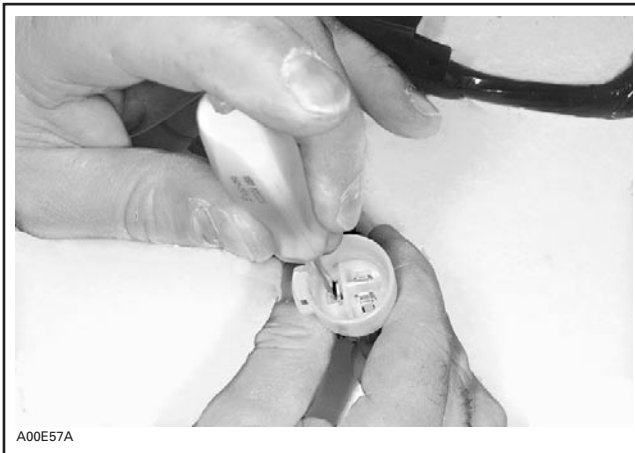

**Multilock Connector Housing
Female Connector Housing**

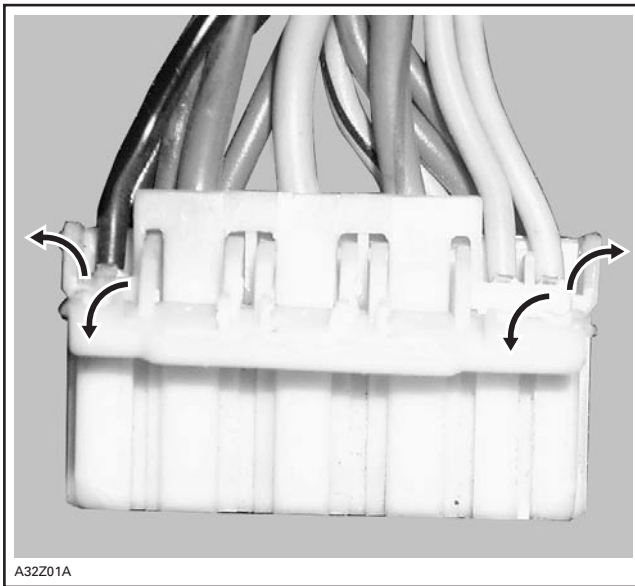

To remove:

- Insert tool AMP- 755430-2 under lock and twist to lift it.

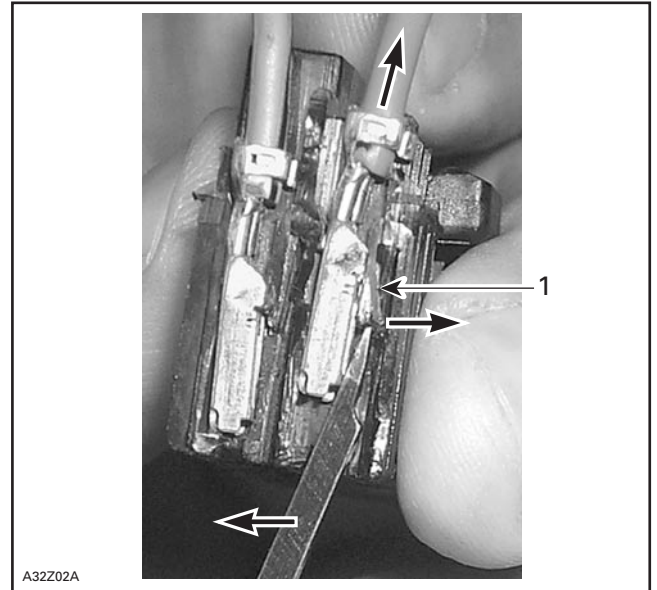

FEMALE CONNECTOR HOUSING — CUT-AWAY

1. Lock

Receptacle connectors can be removed from female housing with sharp head pin.

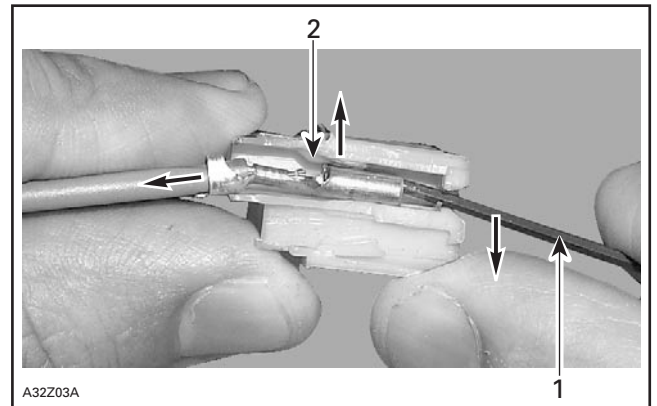

FEMALE CONNECTOR HOUSING — CUT-AWAY

1. Sharp head pin
2. Lock

Section 11 WIRING DIAGRAMS

Subsection 01 (WIRING DIAGRAMS)

Male Connector Housing

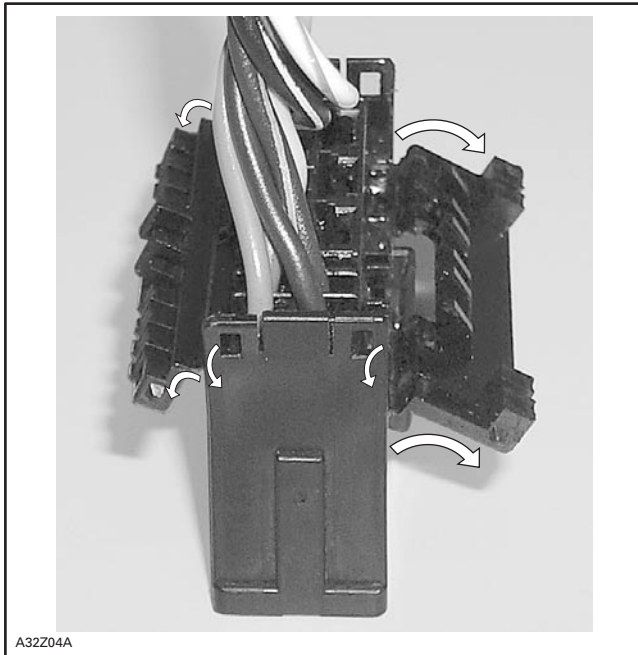

To remove:

- Insert tool AMP- 755430-2 under lock and twist to lift it.

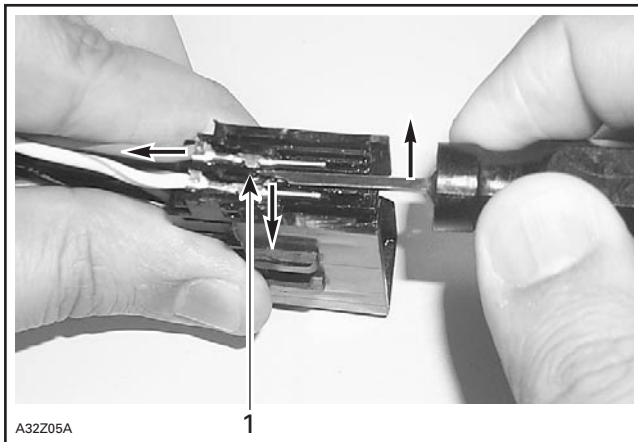

MALE CONNECTOR HOUSING — CUT-AWAY

1. Lock

24-Circuit Connector Housing

Push on both tabs to remove retainer.

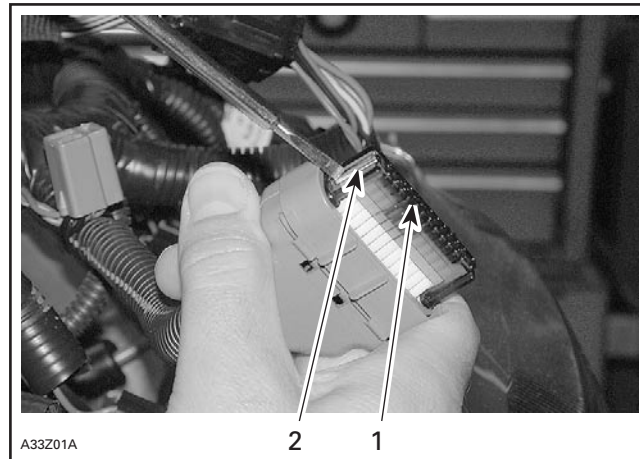

1. Retainer
2. Tab (one on each side)

Open housing by lifting 4 tabs.

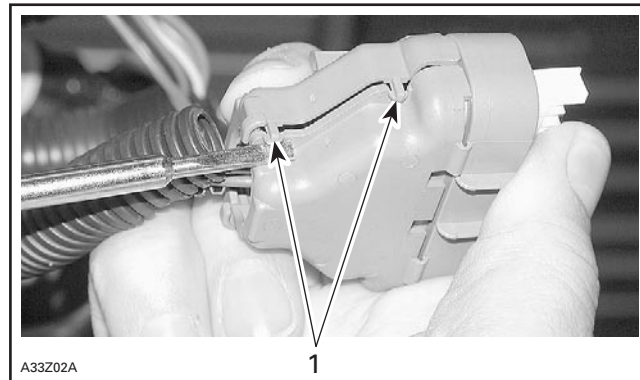

1. Tabs (2 on each side)

Lift plastic lock of the female terminal to be removed. Pull on the female terminal wire to remove female terminal from housing.

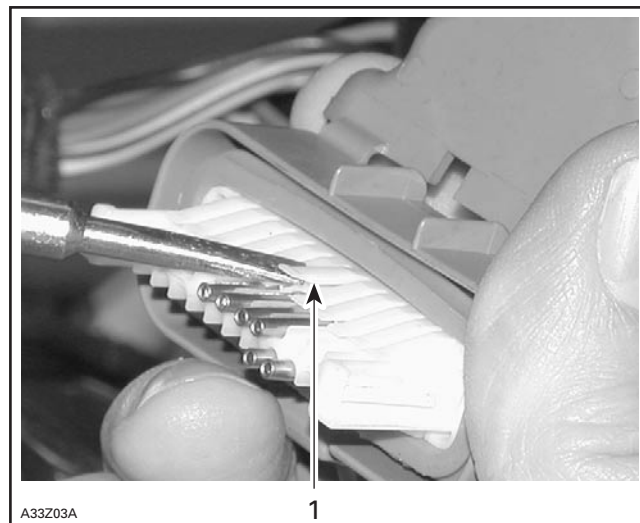

1. Plastic lock

8-Circuit Connector Housing

Pry housing to release lock.

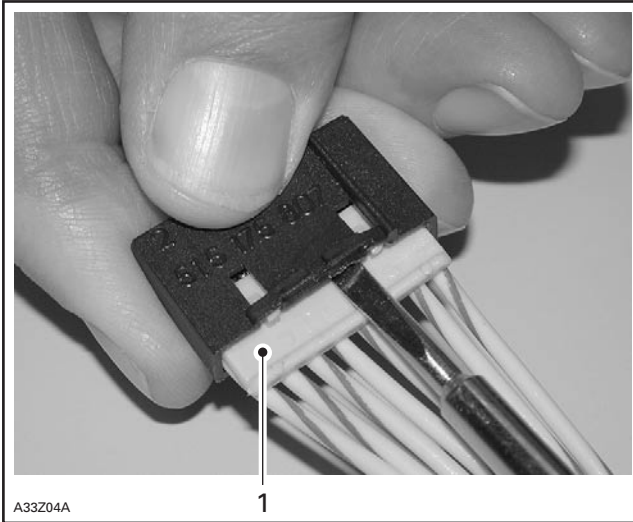

1. Lock

Insert tool AMP- 755430-2 under tab and pry it to free connector. Pull on the female terminal wire to remove female terminal from housing.

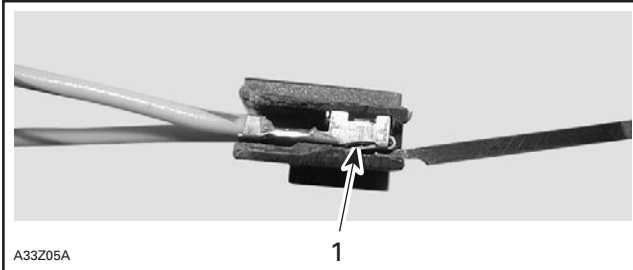

8-CIRCUIT CONNECTOR HOUSING — CUT-AWAY

1. Tab

TAB AND RECEPTACLE CONNECTORS INSTALLATION

Prior to installing, make sure locking tab is sufficiently lifted to properly lock.

Insert tab and receptacle connectors in their respective housings as shown in following illustrations. Push sufficiently so that they snap. Try pulling wire to ensure they are properly locked.

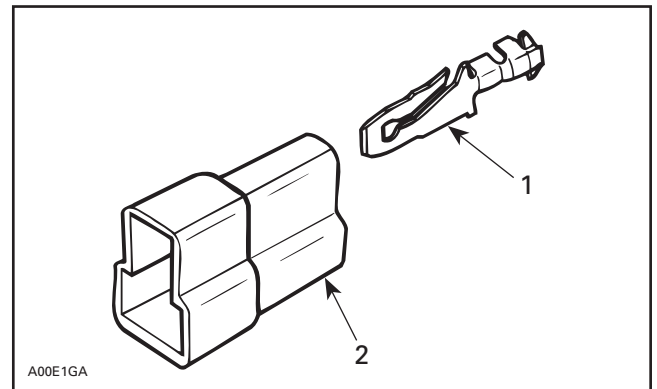

1. Tab
 2. Housing

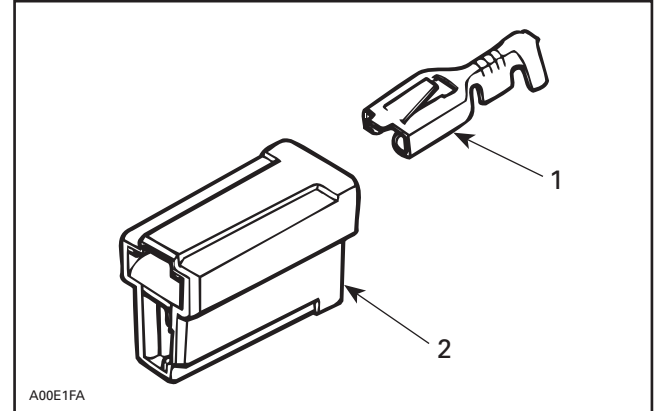

TYPICAL
 1. Receptacle
 2. Housing

⚠ WARNING
 Keep wires away from any rotating, moving, heating, vibrating or sharp edge. Use proper fastening devices as required.

2003 REV ELECTRIC

DESS SWITCH

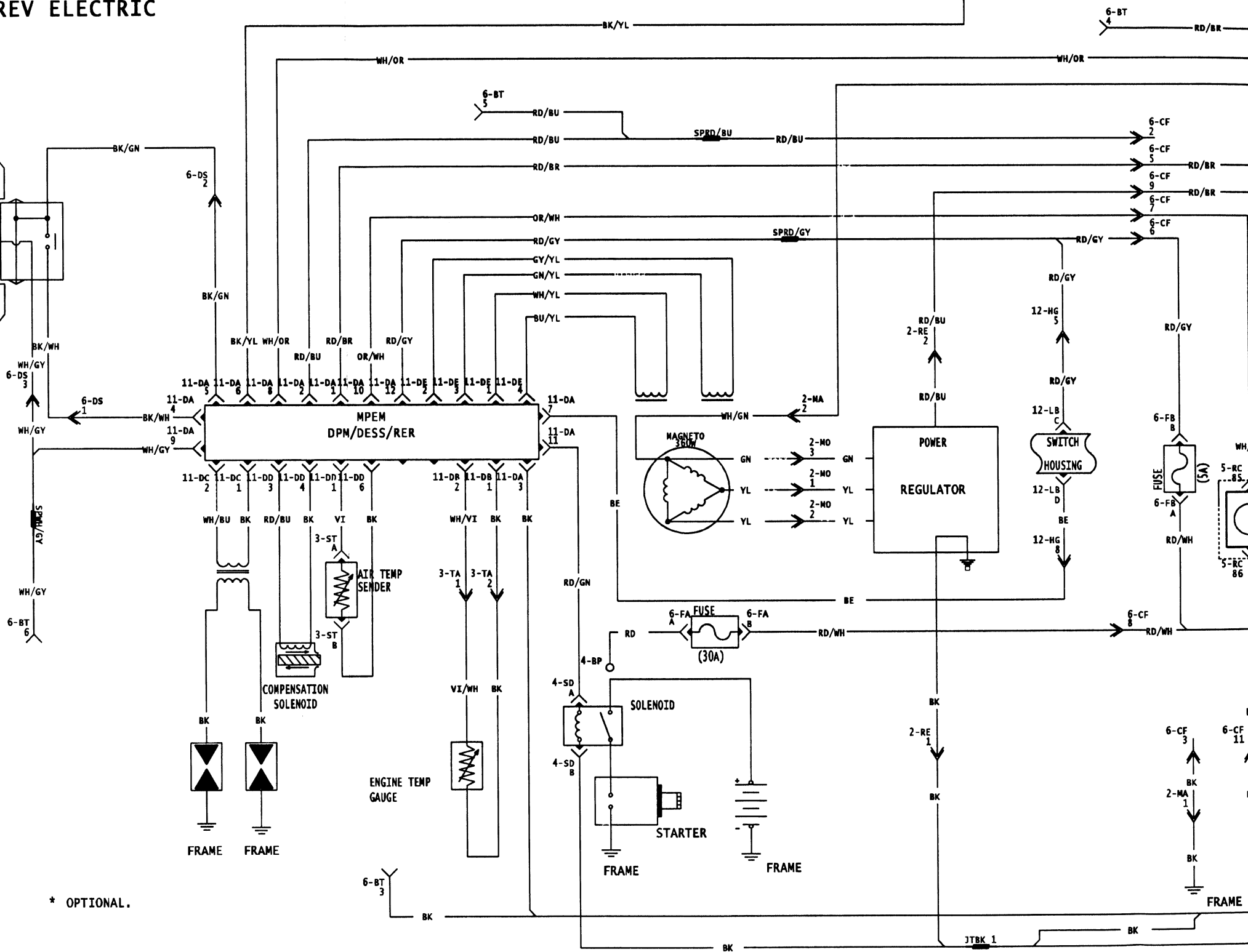
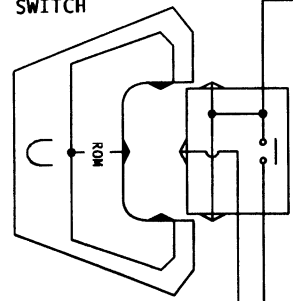

* OPTIONAL.

JTBK 1

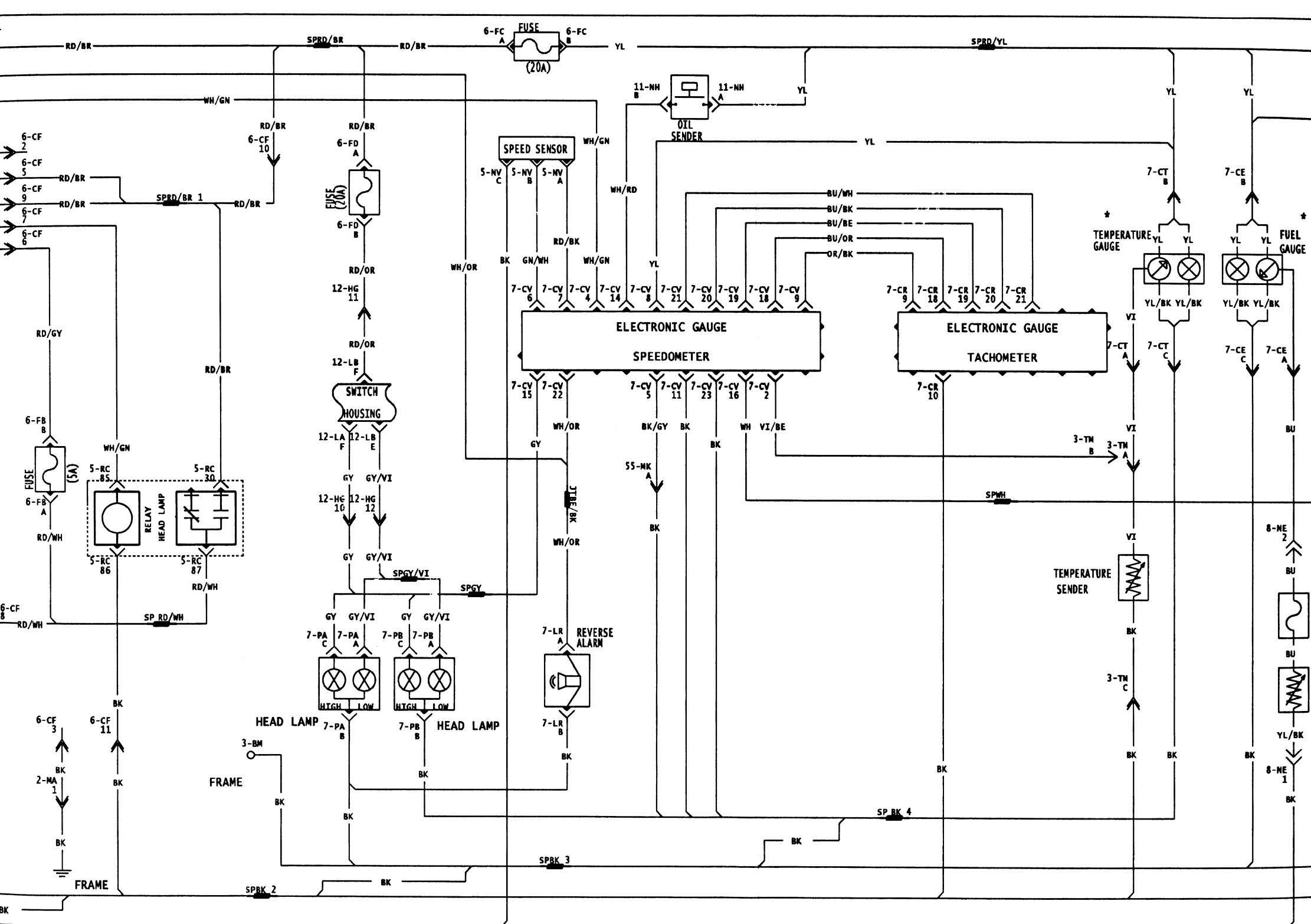

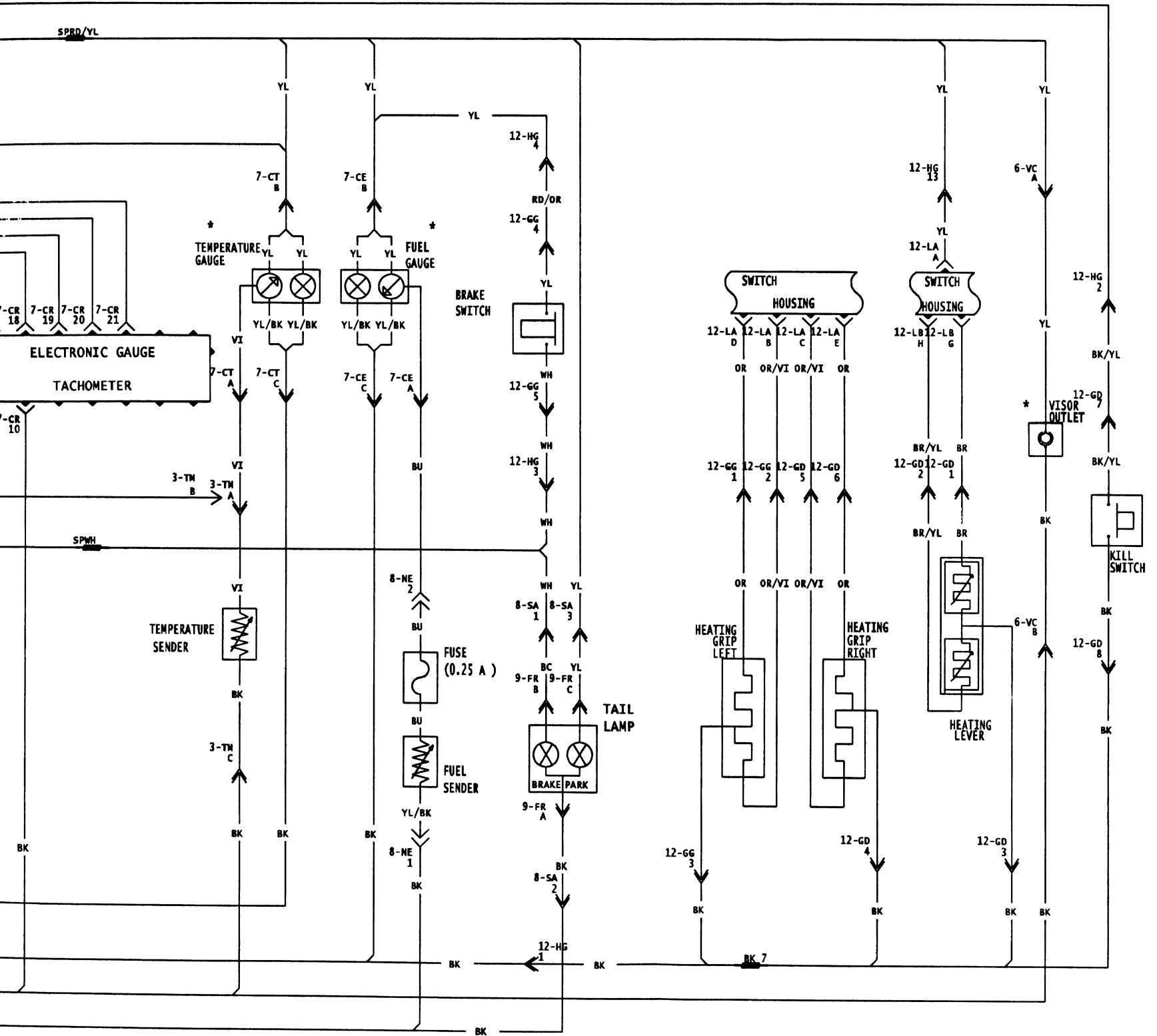

DESS SWITCH

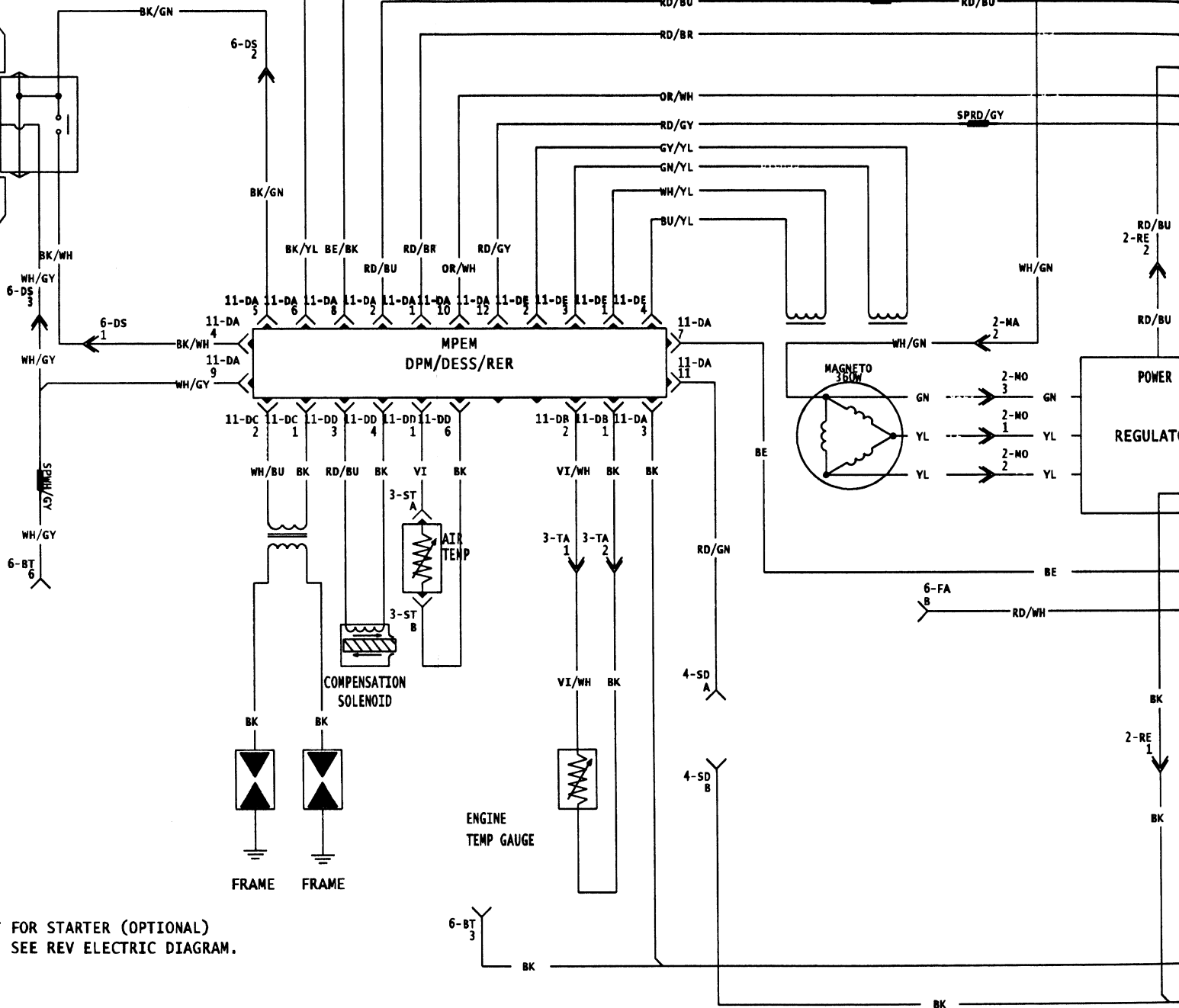
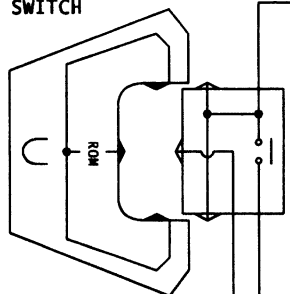

* FOR STARTER (OPTIONAL)
SEE REV ELECTRIC DIAGRAM.

