

# TABLE OF CONTENTS

---

<b>BODY</b> .....	<b>09-02-1</b>
<b>INSTALLATION AND ADJUSTMENT</b> .....	<b>09-02-1</b>
HEADLAMP BEAM AIMING .....	09-02-1
BULB REPLACEMENT .....	09-02-1
DECAL .....	09-02-2
BELT GUARD .....	09-02-2
WIRING HARNESS .....	09-02-2
CABLES .....	09-02-2
PIPING .....	09-02-2
<b>PLASTIC MAINTENANCE AND REPAIR</b> .....	<b>09-02-3</b>
MAINTENANCE .....	09-02-3
REPAIR .....	09-02-3
REPAIR PROCEDURE FOR R.I.M. URETHANE .....	09-02-4

---

<b>FRAME</b> .....	<b>09-03-1</b>
FRAME CLEANING .....	09-03-1
FRAME WELDING .....	09-03-1

# BODY

## INSTALLATION AND ADJUSTMENT

### HEADLAMP BEAM AIMING

Beam aiming is correct when center of high beam is 25 mm (1 in) below the headlamp horizontal center line, scribed on a test surface, 381 cm (12 ft 6 in) away.

Measure headlamp center distance from ground. Scribe a line at this height on test surface (wall or screen). Light beam center should be 25 mm (1 in) below scribed line.

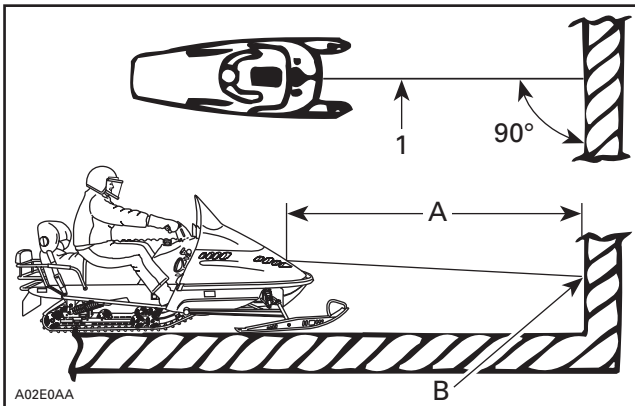

1. Headlamp center line
- A. 381 cm (12 ft 6 in)
- B. 25 mm (1 in) below center line

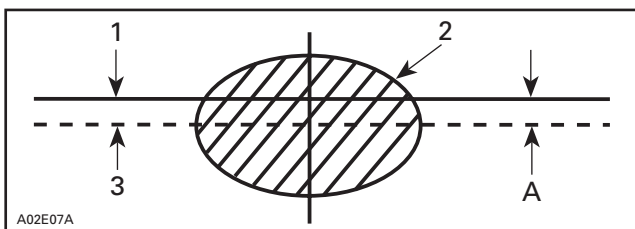

1. Headlamp horizontal
2. Light beam (high beam) (projected on the wall)
3. Light beam center
- A. 25 mm (1 in)

### Required Conditions

Place the vehicle on a flat surface perpendicular to test surface (wall or screen) and 381 cm (12 ft 6 in) away from it.

Rider or equivalent weight must be on the vehicle.

Select **high** beam.

### BULB REPLACEMENT

If headlamp bulb is burnt, tilt cab and unplug the connector from the headlamp. Remove the rubber boot and unfasten the bulb retainer clips or locking ring.

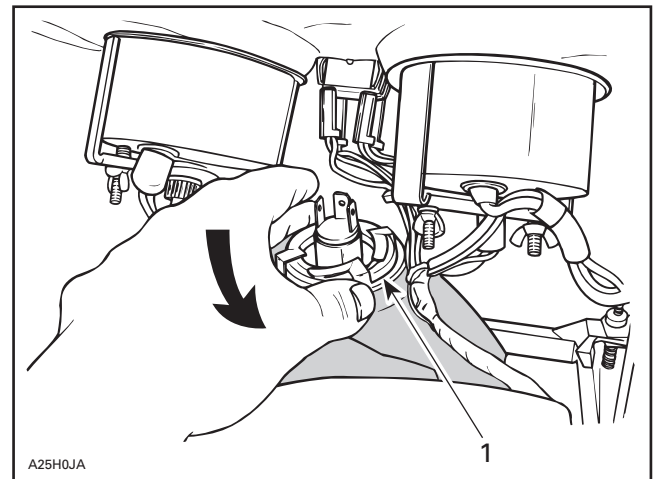

#### TYPICAL

1. Locking ring

Replace bulb. If the taillight bulb is burnt, expose the bulb by removing red plastic lens. To remove, unscrew the 2 retaining screws. Verify all lights after replacement.

**CAUTION:** Never touch glass portion of an halogen bulb with bare fingers, as it shortens its operating life. If by mistake glass is touched, clean it with isopropyl alcohol which will not leave a film on the bulb.

---

## Section 09 BODY/FRAME

### Subsection 02 (BODY)

---

#### DECAL

To remove a decal; heat old decal with a heat gun and peel off slowly.

Using isopropyl alcohol, clean the surface and dry thoroughly.

Apply liquid soap to new decal and carefully position the decal. Using a sponge or a squeegee, remove the air bubbles and surplus water working from the center toward the edges. Allow to air dry.

**CAUTION:** Do not apply isopropyl alcohol or solvent directly on decals.

#### BELT GUARD

##### Disassembly and Assembly

**NOTE:** For additional information (ex.: exploded view) refer to the corresponding *Parts Catalog*.

#### WARNING

Engine should be running only with belt guard well-secured in place.

#### Inspection

##### **All Models**

Check belt guard mounting bosses, clips and retainers for wear.

#### WIRING HARNESS

#### WARNING

Ensure all terminals are properly crimped on the wires and that all connector housings are properly fastened. Keep wires away from any rotating, moving, heating and vibrating parts. Use proper fastening devices as required.

#### CABLES

#### WARNING

Before installation, ensure that all cables are in perfect condition. Properly install the cable ends and secure them in place. Pay attention to route them properly, away from any rotating, moving, heating, or vibrating parts.

#### PIPING

#### WARNING

Always ensure that the fuel, vent, primer, impulse, injection oil and rotary valve oil lines are properly fixed to their connectors, that they are not perforated or kinked and that they are properly routed away from any rotating, moving, heating or vibrating parts. Also check for leaks. Replace if required.

**NOTE:** Refer to proper *Parts Catalog* to find suitable clip part numbers.

## PLASTIC MAINTENANCE AND REPAIR

### MAINTENANCE

Clean the vehicle thoroughly, removing all dirt and grease accumulation.

To clean use a soft clean cloth and either soapy water or isopropyl alcohol.

To remove grease, oil or glue use isopropyl alcohol.

**CAUTION:** Do not apply isopropyl alcohol or acetone directly on decals.

**CAUTION:** The following products must not be used to clean or wax any of the plastic components used on the vehicles:

- gasoline
- brake fluid
- kerosene

- diesel fuel
- lighter fluid
- varsol
- naphtha
- acetone
- strong detergents
- abrasive cleaners
- waxes containing an abrasive or a cleaning agent in their formula.

Apply wax on glossy finish only. Protect the vehicle with a cover to prevent dust accumulation during storage.

**CAUTION:** If for some reason the snowmobile has to be stored outside it is preferable to cover it with an opaque tarpaulin. This will prevent the sun rays from affecting the plastic components and the vehicle finish.

### REPAIR

The very first step before repairing plastic materials is to find out exactly which type of material is involved. Refer to following chart.

**CAUTION:** Consult chart and repair kit instructions carefully, some repair products are not compatible with certain plastics.

#### ⚠ WARNING

Polycarbonate windshields must never be repaired by welding or otherwise.

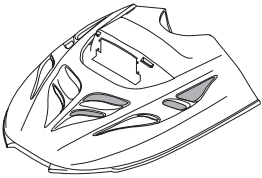
PART	MODEL	IRREPAIRABLE	REPAIRABLE
		HIGH DENSITY POLYETHYLENE	R.I.M. URETHANE
HOOD  <small>A06H194</small>	Tundra R		
	Skandic LT/WT/SWT/WT LC		
BOTTOM PAN	Tundra R		
	Skandic LT/WT/SWT/WT LC		

## Section 09 BODY/FRAME

### Subsection 02 (BODY)

## REPAIR PROCEDURE FOR R.I.M. URETHANE

R.I.M. urethane is light colored (tan) on the inside with a smooth surface.

### WARNING

Material should be repaired and repainted in a well-ventilated area only.

**CAUTION:** Clean R.I.M. with isopropyl alcohol or Crest Hi-Solv product. **Never** use cleaners or products that contain **chlorine**.

**CAUTION:** R.I.M. should never be exposed to temperatures exceeding 93°C (200°F).

**NOTE:** When working on a R.I.M. surface, never use a grinder or a high revolution tool such as an air or electric buffer. Use of such tools could over-heat material and liberate agents in it thus causing a bad adhesion.

### Small Scratches

- Sand and scuff area.
- Feather out edges.
- Paint with a matching acrylic auto touch-up paint.

### Deep Scratches

- Sand and scuff area.
- Make a V groove using a knife or a rough round file.
- Clean surface with isopropyl alcohol or Crest Hi-Solv stock no. AH-S product.
- Cover with TP-E epoxy mixed in equal quantities.
- Heat the surface with a heater lamp placed at 38 cm (15 in) for a period of 15 minutes.

- Sand the surface using a smooth dry sand paper.
- Use the same product if a final finish is required.
- Clean surface with Crest Hi-Solv product.
- Apply a flexible primer such as Crest Prima Flex stock no. AP-F.
- Wait 10 minutes.
- Repaint (air dry during 72 hours (approximately)).

### Large Crack

- Sand and scuff outside and inside area by exceeding it 31.7 mm (1-1/4 in) on each side and 12.7 mm (1/2 in) at each end.
- Make a V groove (appr. 90°) on both sides of hood using a knife or a rough round file.
- Enlarge the crack to 2.4 mm (3/32 in) – 3.2 mm (1/8 in) using a sharp knife.
- Clean outside and inside surface with isopropyl alcohol or Crest Hi-Solv product.
- Repair inside surface first.
- Cover inside area with Crest TP-E epoxy.
- Apply a 50 mm × 30 mm (2 in × 1-1/4 in) patch. If no room for the patch, use tape.
- Cover exterior surface with same product. Damaged area should be slightly higher.
- Heat surface with a heater lamp placed at 38 mm (1.5 in) for a period of 15 minutes.
- Sand outside surface using a smooth dry sand paper.
- Use same product if a final finish is required.
- Apply a flexible primer.
- Wait 10 minutes.
- Repaint (air dry during 72 hours approximately).

**NOTE:** R.I.M. materials are high static plastics, painting must be done in a dust free area such as a paint booth.

**Section 09 BODY/FRAME****Subsection 02 (BODY)**

Crest products used in R.I.M. repair procedure are available from following locations:

<b>CREST MAIN OFFICE AND MANUFACTURING PLANT</b>	
<p><b>CREST INDUSTRIES, INC.</b> 1337 King Road Trenton, Michigan, U.S.A. 48183</p>	<p>Phone: 734-479-4141 Toll Free: 1-800-822-4100 Fax: 734-479-4040 E-Mail: info@crestauto.com www.crestauto.com</p>

<b>DISTRIBUTOR WAREHOUSE LOCATIONS</b>		
<b>UNITED STATES</b>		<b>CANADA</b>
<p><b>CREST EAST COAST, INC.</b> P.O. Box 550 1109 Industrial Parkway Brick, New Jersey 08723 Phone: 732-458-9000 Fax: 732-458-5753</p> <p><b>CREST PRODUCTS, INC.</b> <i>Shipping Address:</i> 125 Production Drive Yorktown, Virginia 23693 Phone: 757-599-6572 Virginia: 1-800-572-5025 Outstate: 1-800-368-5033 Fax: 757-599-6630</p> <p><i>Mailing Address:</i> P.O. Box 2018 Grafton, Virginia 23692</p> <p><b>CREST INDUSTRIES SOUTHEAST, INC.</b> <i>Shipping Address:</i> 1400-B Woodstock Rd. Roswell, Georgia 30075</p> <p><i>Mailing Address:</i> 11530 Bowen Road Roswell, Georgia 30075 Phone: 770-642-7670 Toll Free: 1-800-552-0876 Fax: 770-642-7679</p>	<p><b>CREST INDUSTRIES, INC. (CREST MID-WEST)</b> 231 Larkin Williams Ind. Court St. Louis, Missouri 63026 Phone: 314-349-4800 Toll Free: 1-800-733-2737 Fax: 314-349-4888 Toll Free Fax: 1-800-776-2737 E-Mail: info@crestmidwest.com www.crestmidwest.com</p> <p><b>CREST MID WEST REGIONAL BRANCH WAREHOUSES</b></p> <p><b>CREST INDUSTRIES, INC.</b> P.O. Box 635 Mountain Home, Arkansas 72653 Phone: 501-491-5583 Toll Free: 1-800-733-2737</p> <p><b>CREST INDUSTRIES, INC.</b> 4200 Jackson Street, Unit 9 Denver, Colorado 80216 Phone: 303-320-3900 Toll Free: 1-800-733-2737 Fax: 303-320-6509</p> <p><b>REM-CO DISTRIBUTING, INC.</b> 5625 S. Adams Tacoma, Washington 98409 Phone: 253-474-5414 Toll Free: 1-800-735-7224 Fax: 253-474-7339</p>	<p><b>J2 PRODUCTS A DIVISION OF SAWILL LTD.</b> 54 Audia Court, Unit 2A Concord, Ontario, L4K 3N4 <i>Phone:</i> Toronto: 416-665-1404 Concord: 905-669-9410</p> <p><i>Fax:</i> Concord: 905-669-9419 E-Mail: info@j2.on.ca www.j2.on.ca</p> <p><b>WHEEL-IN AUTOMOTIVE SUPPLY</b> <i>Shipping Address:</i> No. 1, 3911A Brandon St. S.E. Calgary, Alberta, T2G 4A7 Phone: 403-287-0775</p> <p><i>Mailing Address:</i> P.O. Box 40036 929-42<sup>nd</sup> Avenue S.E. Calgary, Alberta, T2G 5G5</p>

# FRAME

## FRAME CLEANING

**NOTE:** For bare aluminum frames use only aluminum cleaner and follow instructions on container. (Dursol cleaner or equivalent).

Clean frame and tunnel with appropriate cleaners and rinse with high pressure hose.

Touch up all metal spots where paint has been scratched off. Spray all bare metal parts of vehicle with metal protector.

## Seat Cleaning

For all models, it is recommended to clean the seat with a solution of **warm soapy water**, using a soft clean cloth.

**CAUTION:** Avoid use of harsh detergents such as strong soaps, degreasing solvents, abrasive cleaners, paint thinners, etc. that may cause damage to the seat cover.

## FRAME WELDING

### Steel Frame:

- electric welding
- amperage: 70-110 A
- voltage: 20-24 V
- electrode: E-7014 (3/32 in).

### Aluminum Frame (refer to specialized welding shop):

Aluminum frame are made of 5052H36 material.

- electric welding: inert gas (argon)
- rod: ER-4043 (3/32 in).

**CAUTION:** Before performing electrical welding anywhere on the vehicle, unplug the multiple connector at the electronic box. On models equipped with a battery, also unplug the negative cable. This will protect the electronic box and battery against damage caused by flowing current when welding.

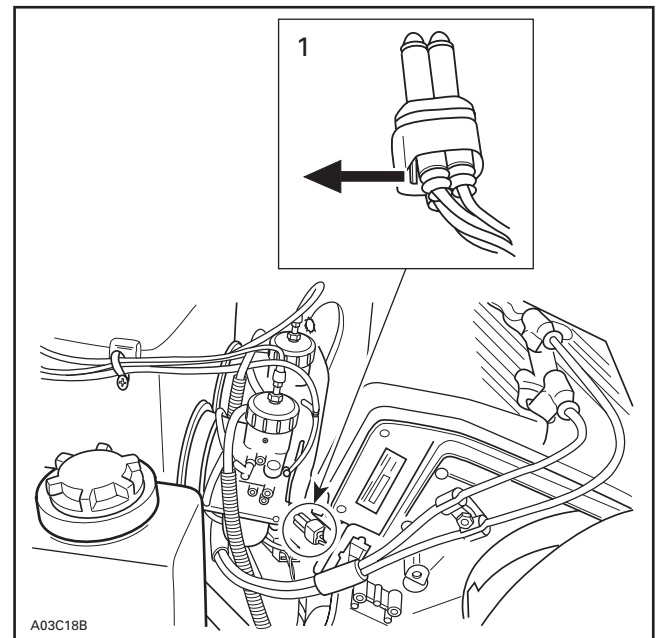

### TYPICAL

1. Unplug before electrical welding

**CAUTION:** If welding is to be done near plastic material, it is recommended to either remove the part from the area or to protect it with aluminum foil to prevent damage.