

TABLE OF CONTENTS

DRIVE BELT	05-02-1
APPLICATION CHART	05-02-1
CLEANING	05-02-1
INSPECTION	05-02-1
ROTATION DIRECTION	05-02-1
DRIVE BELT HEIGHT MEASUREMENT AND ADJUSTMENT	05-02-2
DRIVE BELT DEFLECTION MEASUREMENT (REFERENCE ONLY)	05-02-2
DRIVE PULLEY	05-03-1
BOMBARDIER LITE	05-03-1
GENERAL	05-03-2
REMOVAL	05-03-2
DISASSEMBLY	05-03-2
CLEANING	05-03-3
INSPECTION	05-03-3
ASSEMBLY	05-03-3
INSTALLATION	05-03-3
COMET® 102C	05-03-5
GENERAL	05-03-6
MAINTENANCE	05-03-6
REMOVAL	05-03-6
DISASSEMBLY	05-03-7
CLEANING	05-03-8
INSPECTION	05-03-8
ASSEMBLY	05-03-8
INSTALLATION	05-03-9
TRA	05-03-10
GENERAL	05-03-11
REMOVAL	05-03-11
DISASSEMBLY	05-03-11
CLEANING	05-03-13
INSPECTION	05-03-13
ASSEMBLY	05-03-14
INSTALLATION	05-03-16
DRIVE PULLEY ADJUSTMENT	05-03-17
DRIVEN PULLEY	05-04-1
REMOVAL	05-04-2
DISASSEMBLY	05-04-2
INSPECTION	05-04-3
ASSEMBLY	05-04-4
INSTALLATION	05-04-5
ADJUSTMENT	05-04-5
THRUST BUSHING	05-04-6
LPV 27	05-04-7
DISASSEMBLY	05-04-8

Section 05 TRANSMISSION

Subsection 01 (TABLE OF CONTENTS)

INSPECTION	05-04-8
ASSEMBLY	05-04-9
INSTALLATION	05-04-10
ADJUSTMENT	05-04-10
<hr/>	
PULLEY DISTANCE AND ALIGNMENT	05-05-1
GENERAL	05-05-1
GENERAL PROCEDURE	05-05-1
PULLEY ALIGNMENT AND DISTANCE SPECIFICATIONS CHART	05-05-2
<hr/>	
BRAKE	05-06-1
MECHANICAL BRAKE	05-06-1
HYDRAULIC BRAKE	05-06-3
REMOVAL	05-06-4
DISASSEMBLY	05-06-4
CLEANING	05-06-4
INSPECTION	05-06-4
ASSEMBLY	05-06-5
INSTALLATION	05-06-5
ADJUSTMENT	05-06-6
<hr/>	
CHAINCASE	05-07-1
REMOVAL	05-07-2
DISASSEMBLY	05-07-2
INSPECTION	05-07-2
ASSEMBLY	05-07-3
INSTALLATION	05-07-3
ADJUSTMENT	05-07-3
REMOVAL	05-07-5
INSPECTION	05-07-5
GEAR RATIO MODIFICATION	05-07-5
INSTALLATION	05-07-5
DRIVE CHAIN ADJUSTMENT	05-07-6
ADJUSTMENT	05-07-6
<hr/>	
GEARBOX	05-08-1
3-SPEED GEARBOX	05-08-1
REMOVAL	05-08-2
DISASSEMBLY	05-08-3
INSPECTION	05-08-8
ASSEMBLY	05-08-8
INSTALLATION	05-08-11
OIL LEVEL	05-08-11
<hr/>	
DRIVE CHAIN	05-09-1
GENERAL	05-09-1
SILENT CHAIN	05-09-1
CHAIN ATTACHMENT	05-09-1
CHAIN SEPARATION	05-09-1

DRIVE BELT

APPLICATION CHART

MODEL	PART NUMBER	WIDTH (new) ± 0.25 mm (.010 in)	MINIMUM WIDTH (wear limit)
Tundra R	414 827 600	33.33 mm (1.312 in)	30.00 mm (1.181 in)
Skandic LT/WT/SWT/WT LC	414 633 800	34.60 mm (1.362 in)	32.00 mm (1.260 in)

CLEANING

Before drive belt installation, clean drive and driven pulley sheaves with Part cleaner (P/N 413 711 809).

INSPECTION

Inspect belt for cracks, fraying or abnormal wear (uneven wear, wear on one side, missing cogs, cracked fabric). If abnormal wear is noted, probable cause could be pulley misalignment, excessive RPM with frozen track, fast starts without warm-up period, burred or rusty sheave, oil on belt or distorted spare belt.

Check the drive belt width. Replace the drive belt if width is less than the minimum width recommended (see table above).

ROTATION DIRECTION

The maximum drive belt life span is obtained when the drive belt is installed as shown. This will ensure that correct direction of rotation is respected.

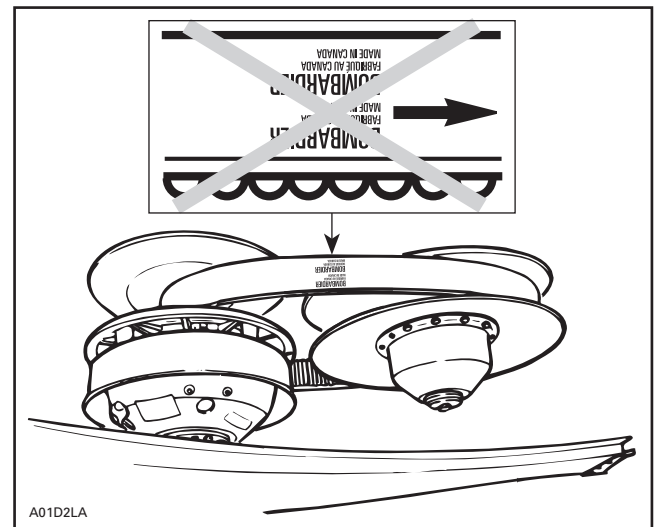

INCORRECT

NOTE: For used drive belt, mark and reinstall in the same position.

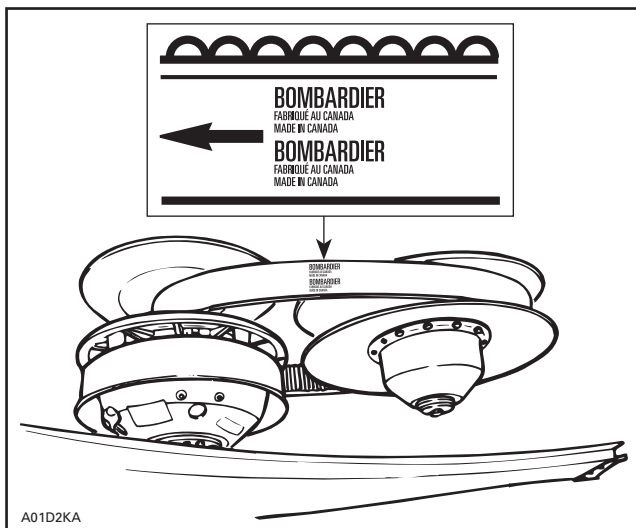

CORRECT

Section 05 TRANSMISSION

Subsection 02 (DRIVE BELT)

DRIVE BELT HEIGHT MEASUREMENT AND ADJUSTMENT

Measurement

Before checking the belt height, ensure that a good-condition proper belt (refer to the application chart) is installed.

Adjust pulley distance and alignment. Refer to PULLEY DISTANCE AND ALIGNMENT.

To obtain maximum vehicle performance, the belt height must be adjusted according to specifications shown in the accompanying chart.

MODEL	BELT HEIGHT mm (in)
All models	Top edge of drive belt cord should be flush with driven pulley edge

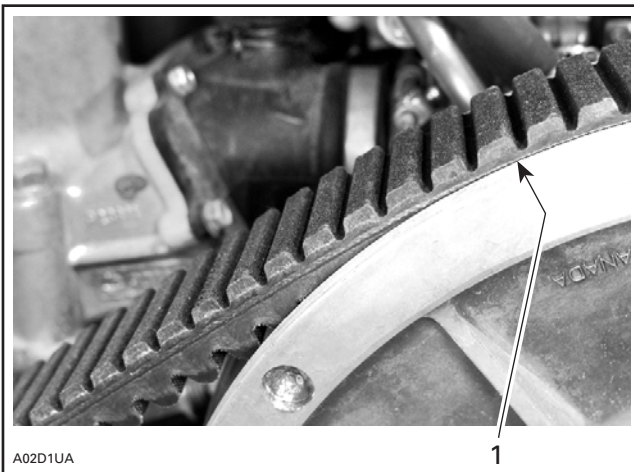

1. Flush

Adjustment

Before adjusting the belt height, ensure that a good-condition proper belt (refer to the application chart) is installed.

Adjust pulley distance and alignment. Refer to PULLEY DISTANCE AND ALIGNMENT.

All Models

Vary pulley distance — within tolerances — to obtain proper drive belt height.

DRIVE BELT DEFLECTION MEASUREMENT (reference only)

IMPORTANT: The drive belt deflection will be automatically set after performing the pulley distance and belt height adjustments. The following procedure will confirm proper pulley distance and belt height adjustment.

NOTE: To obtain an accurate drive belt deflection measurement, it is suggested to allow a break-in period of 50 km (30 m.).

Before checking the belt deflection, ensure that a good-condition proper belt (Refer to the application chart) is installed.

Adjust pulley distance and alignment. Refer to PULLEY DISTANCE AND ALIGNMENT.

MODEL	DEFLECTION† mm (in)	FORCE kg (lb)
Tundra R	32 ± 5 (1-1/4 ± 13/64)	6.8 (15)
All Skandic	32 ± 5 (1-1/4 ± 13/64)	11.3 (25)

† FOR REFERENCE ONLY

To Check Deflection

Position a reference rule on drive belt.

Wooden Stick and Spring Scale Method

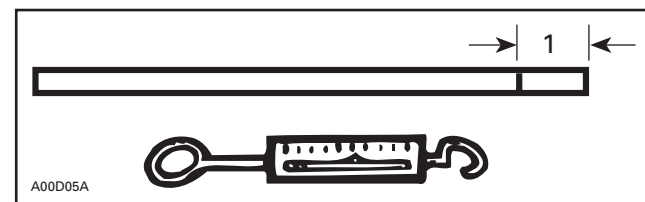

1. Mark specified deflection

Section 05 TRANSMISSION

Subsection 02 (DRIVE BELT)

Using spring scale and stick, apply specified force on drive belt halfway between pulleys as shown.

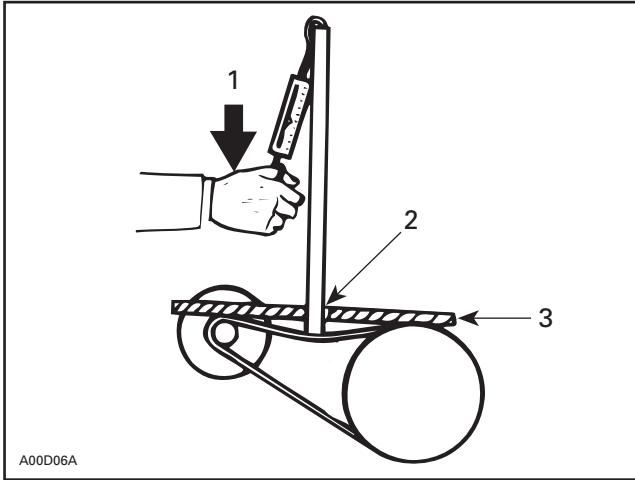

1. Force
2. Read deflection here
3. Reference rule

Or use the belt tension tester (P/N 414 348 200).

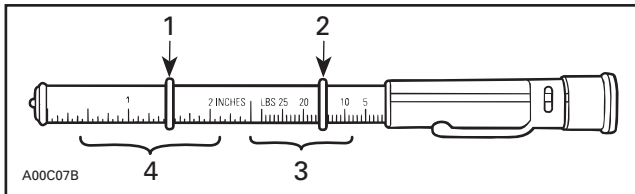

1. Lower O-ring
2. Upper O-ring
3. Force (read down)
4. Deflection (read up)

1. Slide lower O-ring of tester to specified deflection.
2. Slide upper O-ring of tester until reaching mark 0 (zero).
3. Apply pressure until lower O-ring is flush with edge of rule and read force on the upper scale at top edge of O-ring.

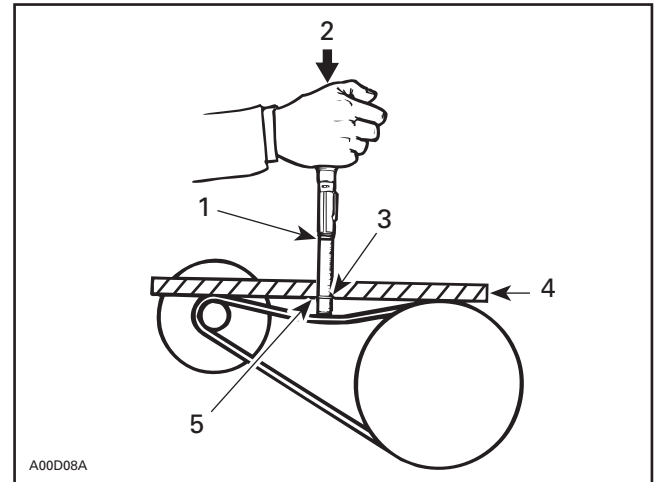

1. Upper O-ring — force
2. Force applied
3. Lower O-ring — deflection
4. Reference rule
5. Deflection

DRIVE PULLEY

BOMBARDIER LITE

NOTE: This is a lubrication free drive pulley.

Tundra R

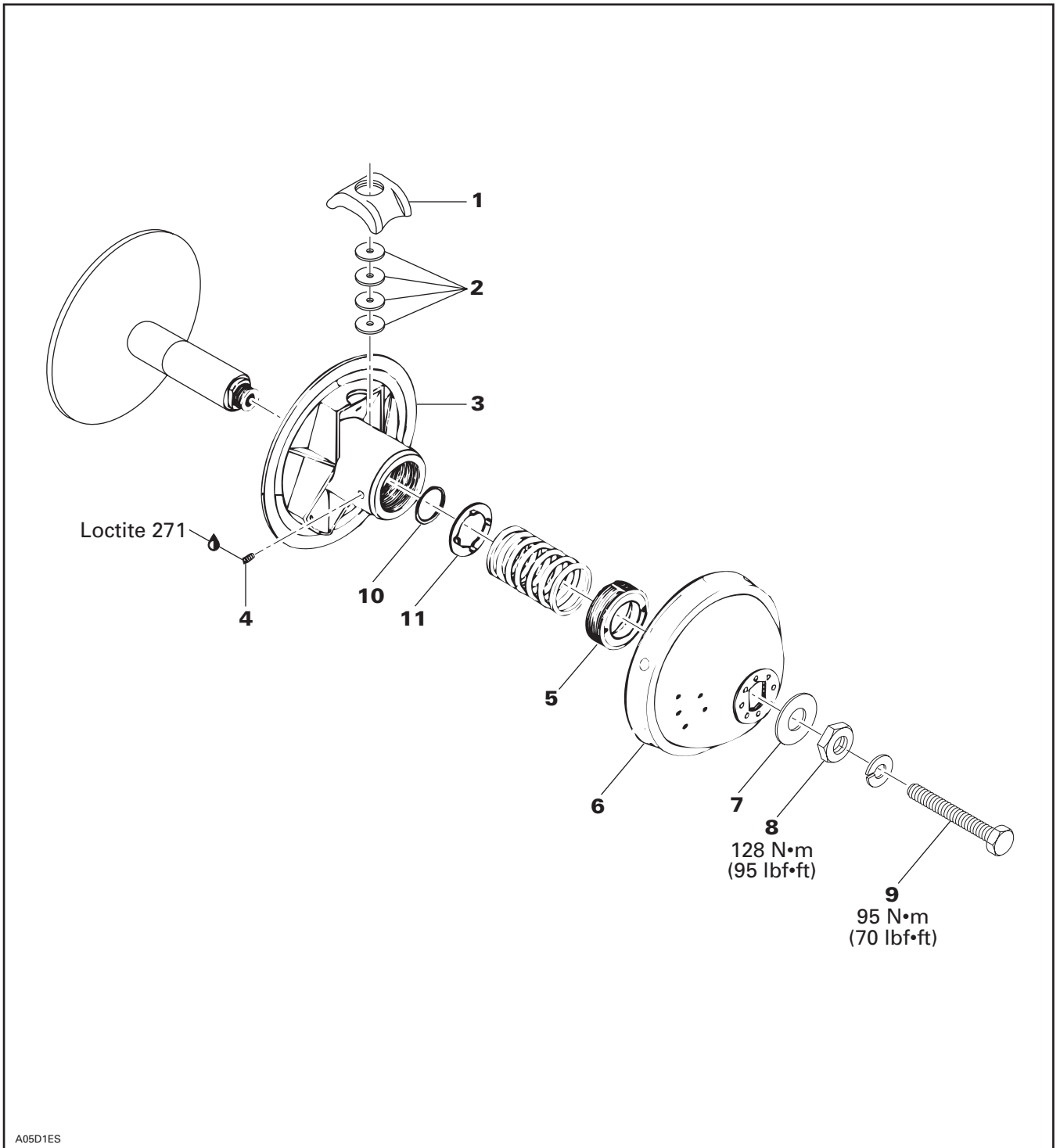

Section 05 TRANSMISSION

Subsection 03 (DRIVE PULLEY)

GENERAL

Some drive pulley components (return spring, calibration disk) can be changed to improve vehicle performance in high altitude regions. A Service Bulletin will give information about calibration according to altitude.

CAUTION: Such modifications should only be performed by experience mechanics since they can greatly affect vehicle performance.

⚠ WARNING

Any drive pulley repairs must be performed by an authorized Bombardier snowmobile dealer. Sub-component installation and assembly tolerances require strict adherence to procedures detailed.

REMOVAL

NOTE: If disassembling drive pulley, first straighten tab washer no. 7 then untighten nut no. 8.

⚠ WARNING

Never use an impact wrench to remove or install the drive pulley.

Use holder (P/N 529 027 600).

Remove retaining screw no. 9.

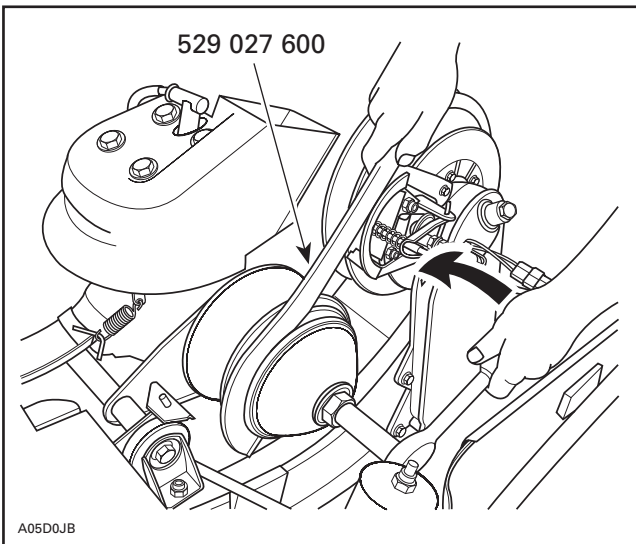

TYPICAL

Insert drive pulley puller (P/N 529 031 400) then remove drive pulley.

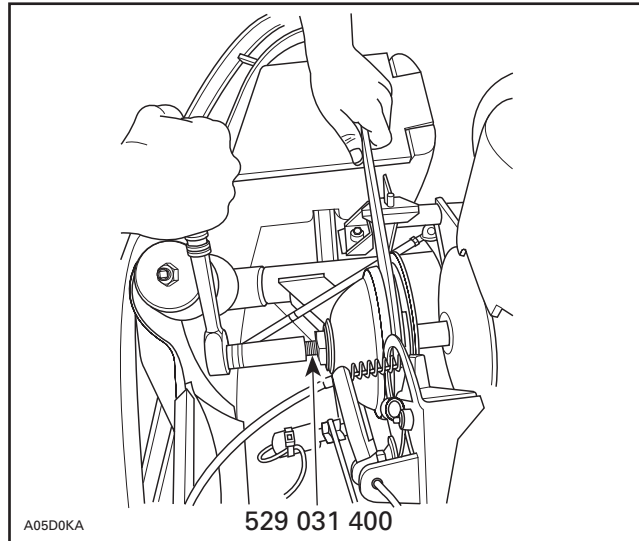

TYPICAL

DISASSEMBLY

Unscrew nut. Remove tab washer.

Check for alignment marks for proper indexing at reassembly.

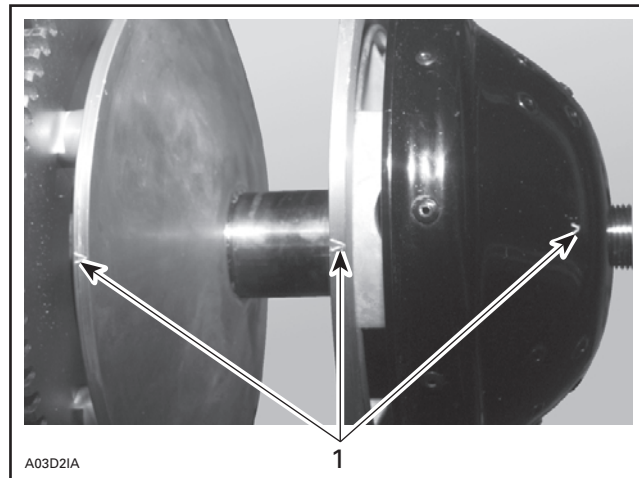

1. Alignment marks

Identify blocks **no. 1** and their respective positive positions for reassembly.

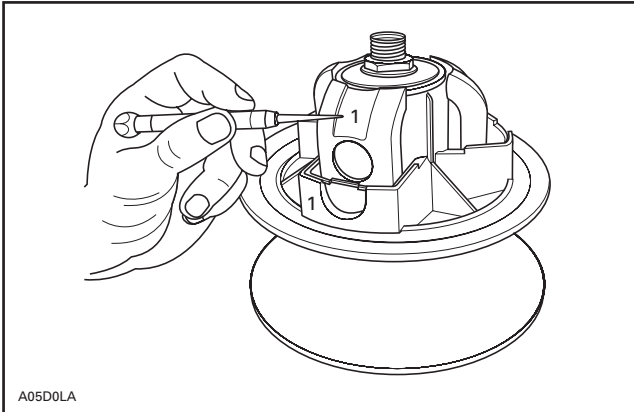

1. Identify

2, Cap, Washer and Disk

These are calibration parts. Refer to TECHNICAL DATA.

Unscrew set screw **no. 4** then use spring cover tool (P/N 529 027 300) to unscrew spring cover **no. 5**.

Mount tool in a vise for cover hand-unscrewing.

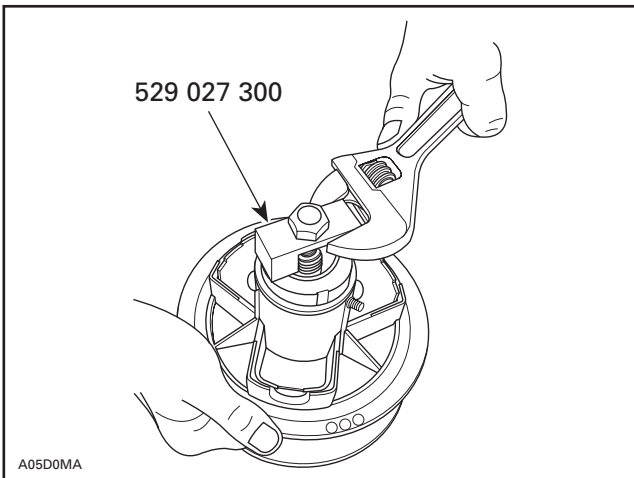

Remove guide washer **no. 11** then circlip **no. 10**.

CLEANING

Clean pulley faces and shaft with fine steel wool and clean dry cloth. Clean sliding half bushing with clean and dry cloth.

INSPECTION

Check sliding half for excessive lateral play and fixed half shaft for scratches. Replace as required.

ASSEMBLY

Install circlip **no. 10** then guide washer **no. 11**.

Make sure to install blocks at their original position and with their curved end toward governor cup. See following illustration.

Screw spring cover to 2 to 3 mm (1/16 to 1/8 in) down below sliding half end. Apply Loctite 271 on screw threads. Install set screw aligned with spring cover slot.

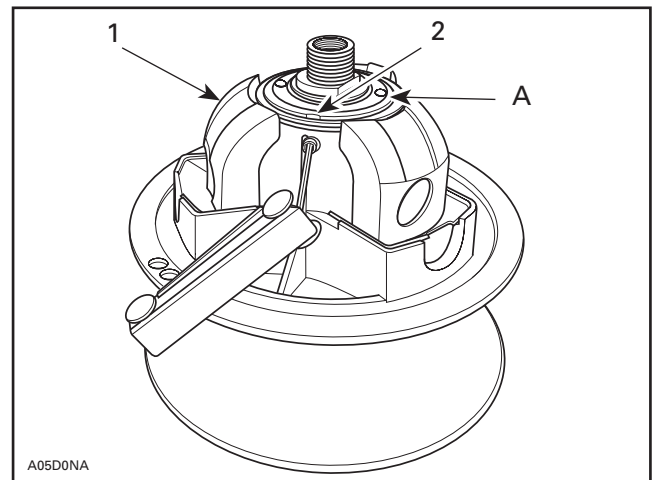

- 1. Curved end
- 2. Spring cover slot
- A. 2 to 3 mm (1/16 to 1/8 in)

Tighten nut **no. 8** to 128 N•m (95 lbf•ft).

INSTALLATION

Install a new lock washer.

Torque screw to 90 to 100 N•m (66 to 74 lbf•ft).

Install drive belt and belt guard.

Section 05 TRANSMISSION

Subsection 03 (DRIVE PULLEY)

Raise the rear of the vehicle and support it with a mechanical stand.

WARNING

Ensure that the track is free of particles which could be thrown out while track is rotating. Keep hands, tools, feet and clothing clear of track. Ensure nobody is standing near the vehicle.

Accelerate the vehicle at low speed (maximum 30 km/h (20 MPH)) and apply the brake, repeat 5 times.

Recheck the torque of 90 to 100 N•m (66 to 74 lbf•ft).

WARNING

After 10 hours of operation the transmission system of the vehicle must be inspected to ensure the retaining screw is properly torqued.

COMET® 102C

Skandic LT

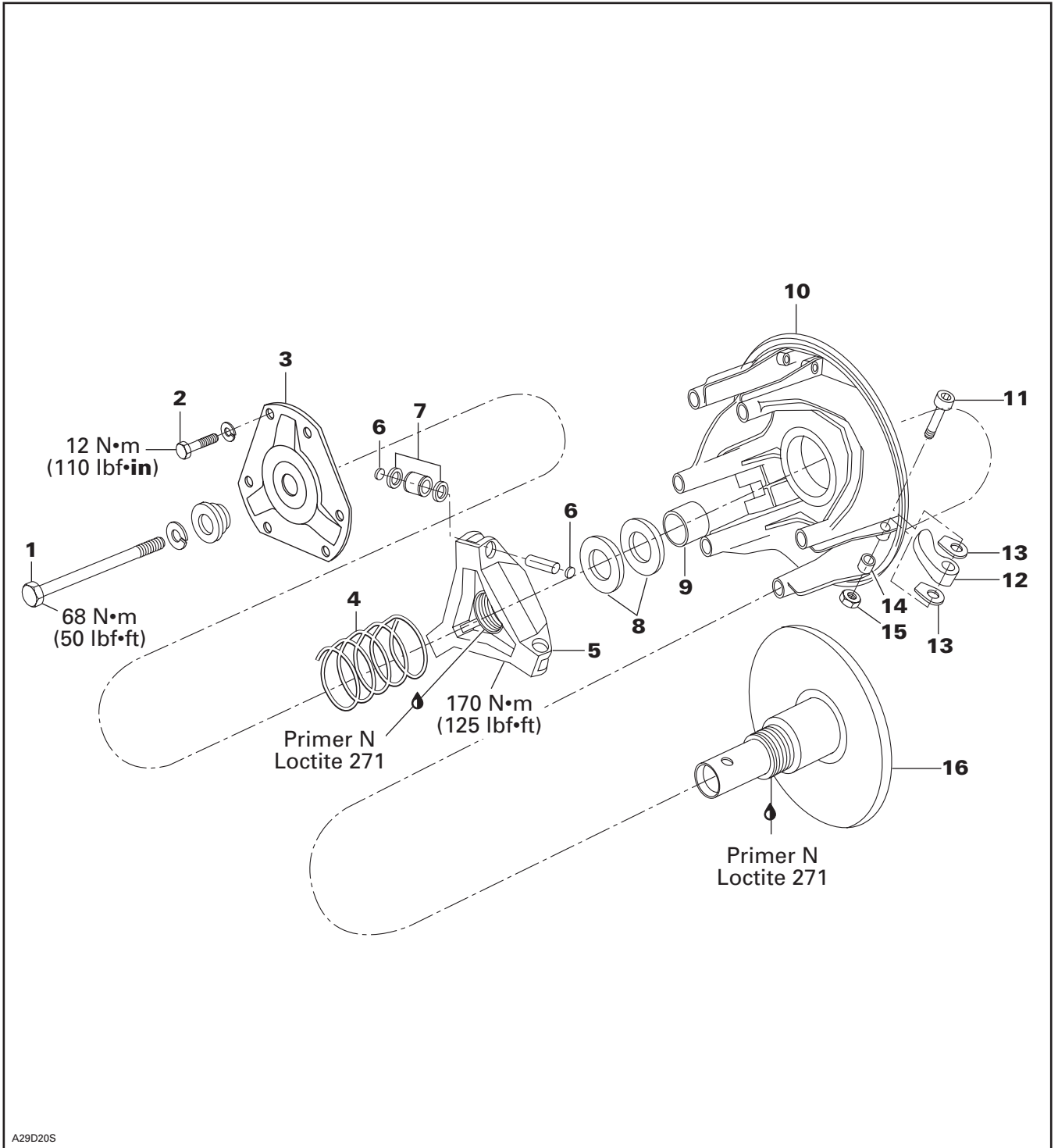

A29D20S

Section 05 TRANSMISSION

Subsection 03 (DRIVE PULLEY)

GENERAL

Some drive pulley components can be changed to improve vehicle performance in high altitude regions. A Service Bulletin will give information about calibration according to altitude.

CAUTION: Such modifications should only be performed by experience mechanics since they can greatly affect vehicle performance.

⚠ WARNING

Any drive pulley repairs must be performed by an authorized Bombardier snowmobile dealer. Sub-component installation and assembly tolerances require strict adherence to procedures detailed.

MAINTENANCE

Cam Arm Pivot Nut

At first 10-hour (500 km) cam arm pivot nuts **no. 15** have to be retighten.

To do so, loosen one turn all cover screws **no. 2**.

Retighten to 5.6 N•m (50 lbf•in) maximum all three pivot nuts **no. 15**. Make sure cam arms **no. 12** can still move on their pivot bolts **no. 11**.

Retighten cover screws **no. 2** to 12 N•m (110 lbf•in). Proceed with one screw per tower in a criss-cross sequence then, remaining three screws.

Cam Arm Bushing

Cam arm bushings **no. 14** have to be replaced every 3000 km (2000 m.).

With drive pulley still installed on crankshaft, remove one cam arm **no. 12** at a time. Install parts included in Cam Arm Kit. Proceed with remaining cam arms.

Loosen one turn all cover screws **no. 2**.

Retighten to 5.6 N•m (50 lbf•in) maximum all three pivot nuts **no. 15**. Make sure cam arms **no. 12** can still move on their pivot bolts **no. 11**.

Retighten cover screws **no. 2** to 12 N•m (110 lbf•in). Proceed with one screw per tower in a criss-cross sequence then, remaining three screws.

REMOVAL

⚠ WARNING

Never use an impact wrench to remove or install the drive pulley.

Unfasten center and rear bottom pan attachments on left hand side. Remove belt guard.

Open driven pulley using driven pulley opening tool (P/N 529 017 200). Remove drive belt.

Use holder (P/N 529 006 400). Make sure holder hook is positioned on top of tower.

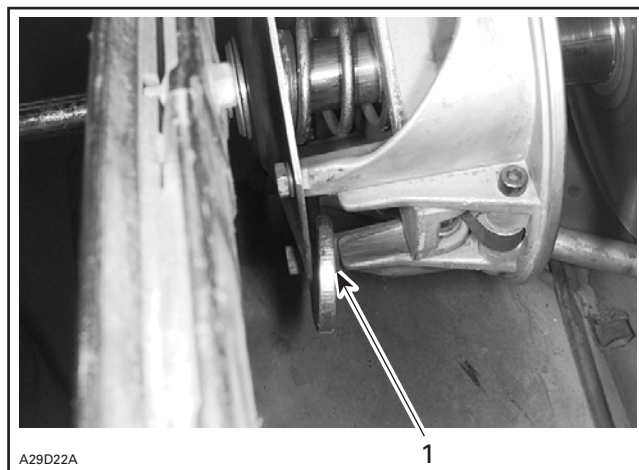

1. Holder hook on top of tower

Remove retaining screw **no. 1**.

Section 05 TRANSMISSION

Subsection 03 (DRIVE PULLEY)

Install holder (P/N 529 006 400) in a way to limit pulley clockwise rotation.

Insert drive pulley puller (P/N 529 025 000) then turn puller clockwise to free drive pulley from crankshaft taper.

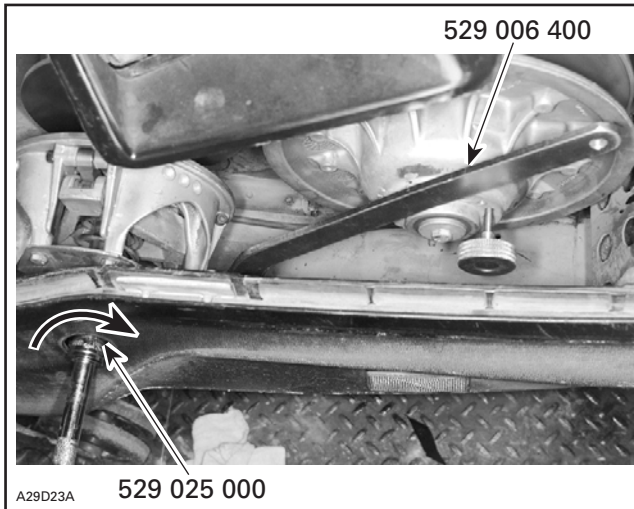

Remove driven pulley to make room for drive pulley removal.

Remove drive pulley.

DISASSEMBLY

Mount tapered tool kit (P/N 529 035 826) in a vise. Install drive pulley over retainer then, fasten retaining screw **no. 1** and torque to 68 N•m (50 lbf•ft). Now drive pulley is locked on retainer.

Scribe pen marks on fixed half **no. 16**, sliding half **no. 10**, spider **no. 5** and cover **no. 3** for proper indexing at reassembly.

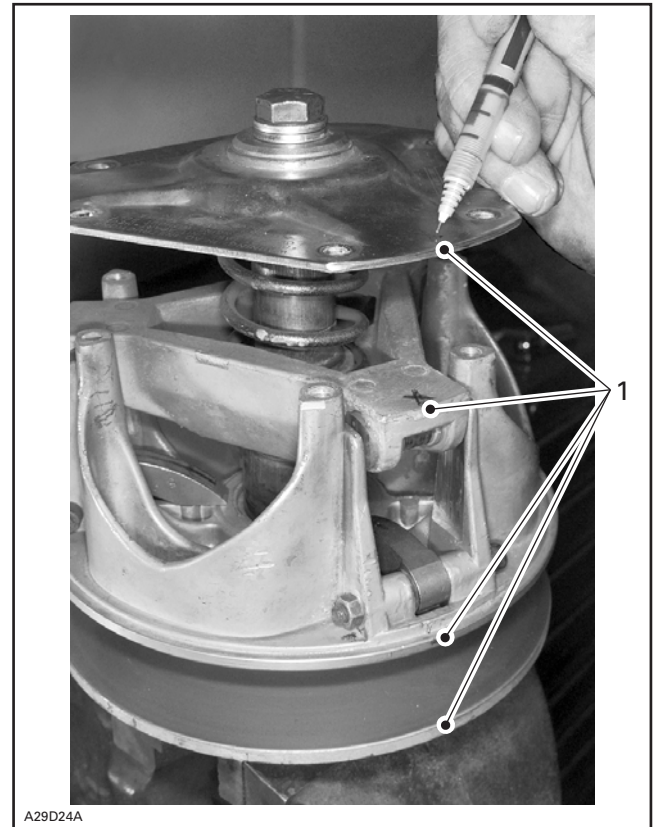

1. Scribe marks

Remove cover screws **no. 2**.

Hold cover **no. 3** by hand then, unscrew retaining screw **no. 1**.

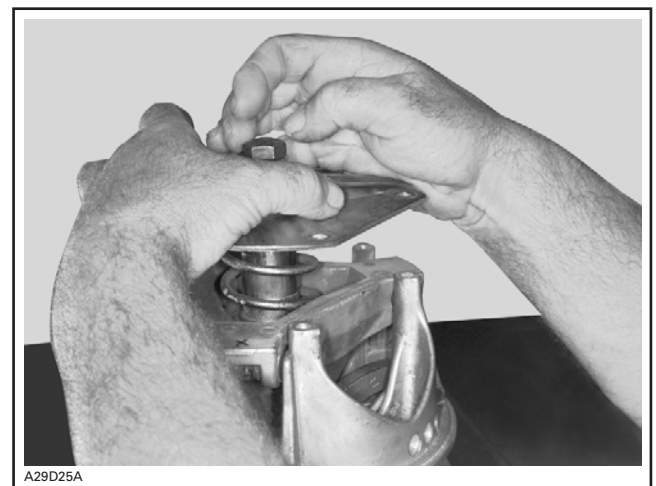

Remove cover **no. 3**.

Section 05 TRANSMISSION

Subsection 03 (DRIVE PULLEY)

Heat spider no. 5 to melt threadlocker.

Install spider tool (P/N 529 025 200) then, unscrew spider no. 5.

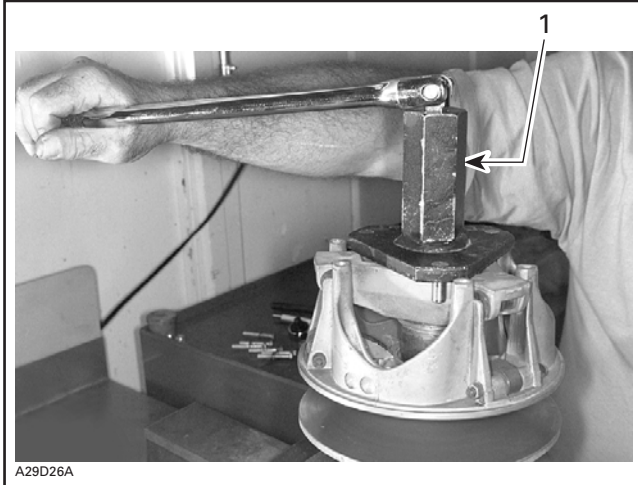

1. Spider wrench

Note shim no. 8 quantity.

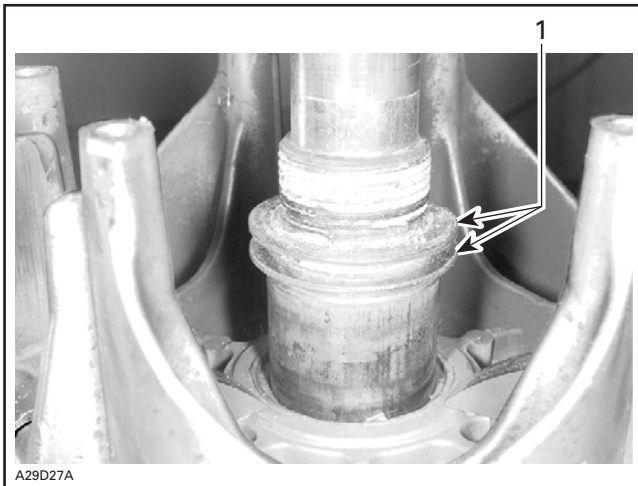

1. Shims

Remove cam arms no. 12.

CLEANING

Clean pulley faces and shaft with fine steel wool and clean dry cloth. Clean sliding half bushing no. 9 and cover bushing with clean dry cloth.

Thoroughly clean spider threads and fixed half post threads.

INSPECTION

Check sliding half for excessive lateral play and fixed half post for scratches. Replace as required.

Check cover bushing interior. Replace cover if bushing is completely bronze instead of the original teflon coating.

Check spider thrust buttons no. 6 for proper sliding action. Replace as required.

Check rollers no. 7 for free action. Replace as required.

ASSEMBLY

Install shims no. 8 on fixed half post.

Apply Primer N (P/N 293 800 041) to both post and spider threads, allow to dry for 10 minutes. Apply Loctite 271 (P/N 293 800 005) to threads.

Using spider wrench from tool kit (P/N 529 025 400) torque spider no. 5 to 170 N•m (125 lbf•ft).

With square end facing sliding half, install a washer no. 13 on each side of cam arm no. 12.

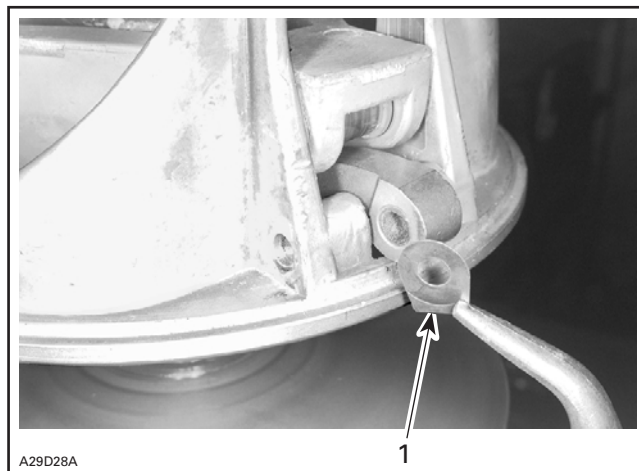

1. Square end facing sliding half

Tighten to 5.6 N•m (50 lbf•in) maximum all three pivot nuts **no. 15**. Make sure cam arms **no. 12** can still move on their pivot bolts **no. 11**.

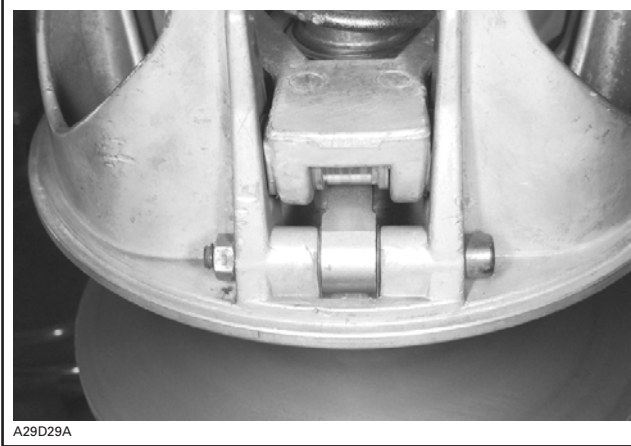

Install spring **no. 4**, cover **no. 3**.

Tighten cover screws **no. 2** to 12 N•m (110 lbf•in). Proceed with one screw per tower in a criss-cross sequence then, remaining three screws.

Use puller (P/N 529 025 000) to unlock drive pulley from retainer.



INSTALLATION

Install drive pulley on crankshaft.

Install a new lock washer.

Torque retaining screw to 68 N•m (50 lbf•ft).

Reinstall driven pulley, drive belt and belt guard. Refasten bottom pan center and rear attachments on left hand side.

Raise the rear of the vehicle and support it with a mechanical stand.

⚠ WARNING

Ensure that the track is free of particles which could be thrown out while track is rotating. Keep hands, tools, feet and clothing clear of track. Ensure nobody is standing near the vehicle.

Accelerate the vehicle at low speed (maximum 30 km/h (20 MPH)) and apply the brake, repeat 5 times.

Recheck the torque of 68 N•m (50 lbf•ft).

⚠ WARNING

After 10 hours of operation the transmission system of the vehicle must be inspected to ensure the retaining screw is properly torqued.

Section 05 TRANSMISSION

Subsection 03 (DRIVE PULLEY)

TRA

Skandic WT/SWT/WT LC

NOTE: This is a lubrication free drive pulley.

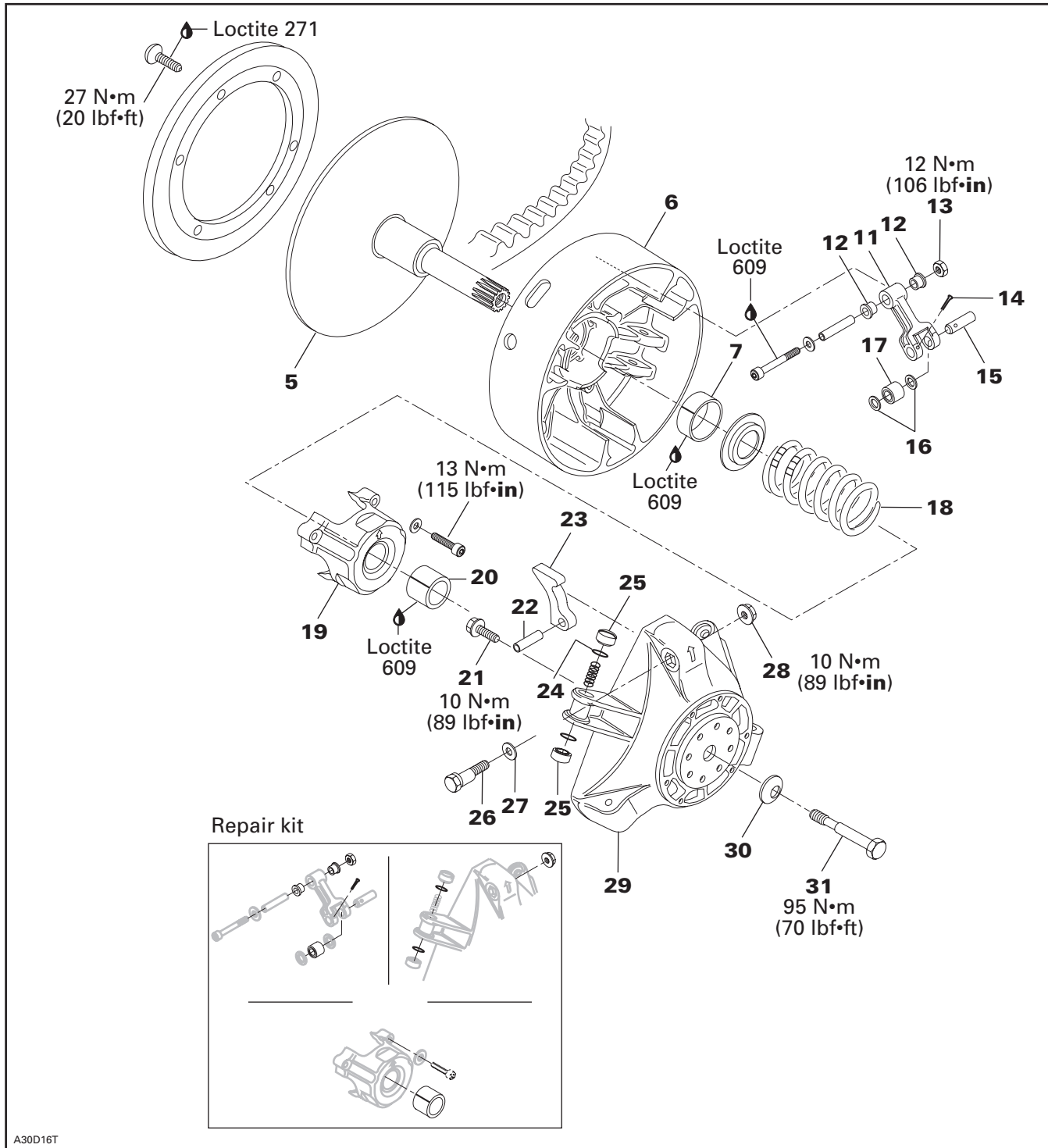

GENERAL

Some drive pulley components (return spring, ramp) can be changed to improve vehicle performance in high altitude regions. A Service Bulletin will give information about calibration according to altitude.

CAUTION: Such modifications should only be performed by experienced mechanics since they can greatly affect vehicle performance. Verify spring specifications before installation. Do not only refer to the spring color code.

NOTE: TRA drive pulley stands for Total Range Adjustable drive pulley.

⚠ WARNING

Any drive pulley repairs must be performed by an authorized Bombardier snowmobile dealer. Sub-component installation and assembly tolerances require strict adherence to procedures detailed.

REMOVAL

30,31, Conical Spring Washer and Screw

Use holder (P/N 529 006 400).

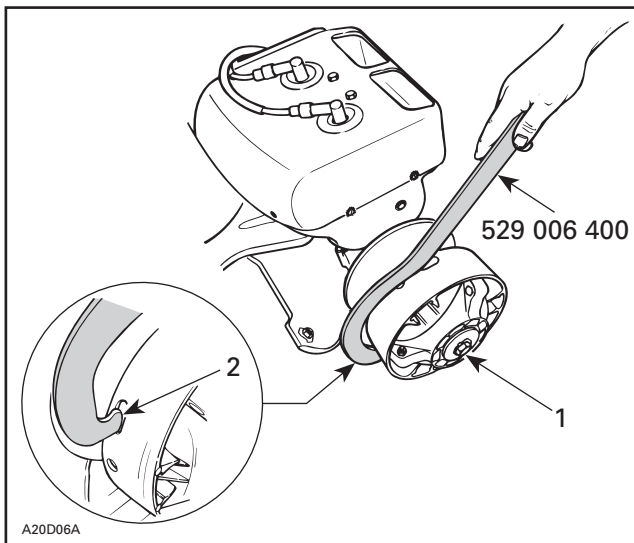

TYPICAL

1. Retaining screw
2. Insert in any slot

⚠ WARNING

Never use any type of impact wrench at drive pulley removal and installation.

⚠ WARNING

The drive pulley assembly is a precisely balanced unit. Never replace parts with used parts from another drive pulley assembly.

Remove retaining screw. Discard conical spring washer.

To remove drive pulley ass'y and/or fixed half from engine, use puller (P/N 529 022 400).

CAUTION: These pulleys have metric threads. Do not use imperial threads puller. Always tighten puller by hand to ensure that the drive pulley has the same type of threads (metric vs imperial) prior to fully tightening.

To Remove Drive Pulley Ass'y

Retain drive pulley with clutch holder.

Install puller in pulley shaft then tighten.

DISASSEMBLY

1,2, Screw and Ring Gear

CAUTION: Retaining screws must be heated before disassembly. Do not exceed 150°C (300°F).

5,6, Fixed and Sliding Half

CAUTION: Do not tap on governor cup.

Screw puller into fixed half shaft about 13 mm (1/2 in). Raise drive pulley and hold it by the sliding half while knocking on puller head to disengage fixed half.

Section 05 TRANSMISSION

Subsection 03 (DRIVE PULLEY)

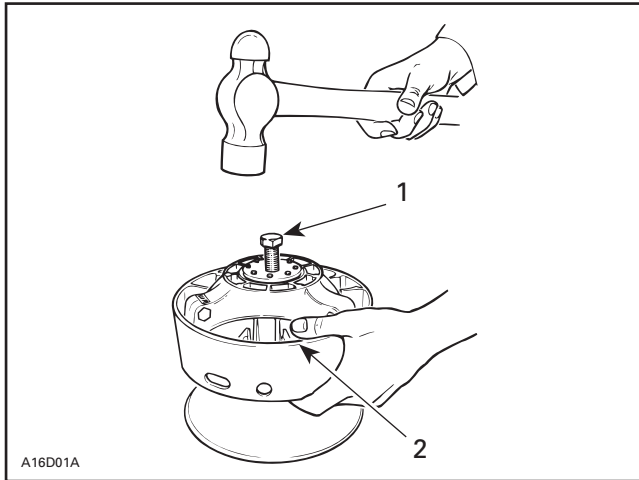

1. Puller
2. Holding sliding half

NOTE: No components marking is required before disassembling this drive pulley since it has factory mark and arrows as indexing reference.

25,29, Slider Shoe and Governor Cup

Carefully lift governor cup until slider shoes come at their highest position into guides.

Hold a slider shoe set then carefully lift its housing and remove slider shoes. Proceed the same way for other housings lifting one at a time.

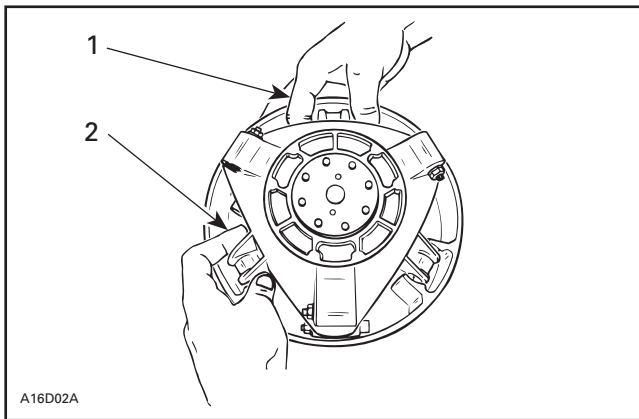

1. Hold slider shoes
2. Lift one housing at a time

NOTE: To ease disassembly, forks (P/N 529 005 500) should be used to hold slider shoes prior to removing governor cup.

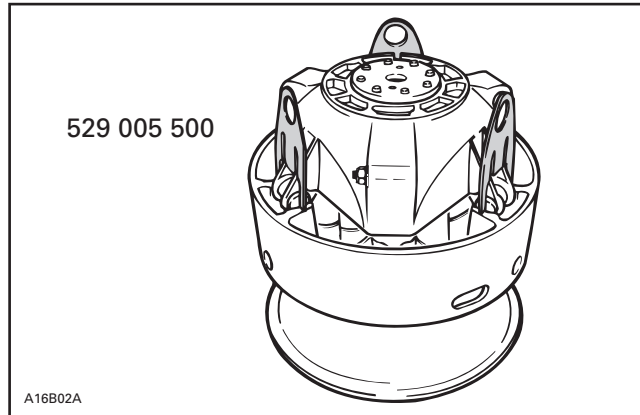

19, Spring Cover Ass'y

It is pushed by clutch spring pressure.

⚠ WARNING

Clutch spring is very strong. Never attempt to remove spring cover without the recommended tools.

Use spring compressor (P/N 529 035 524).

Install support guide.

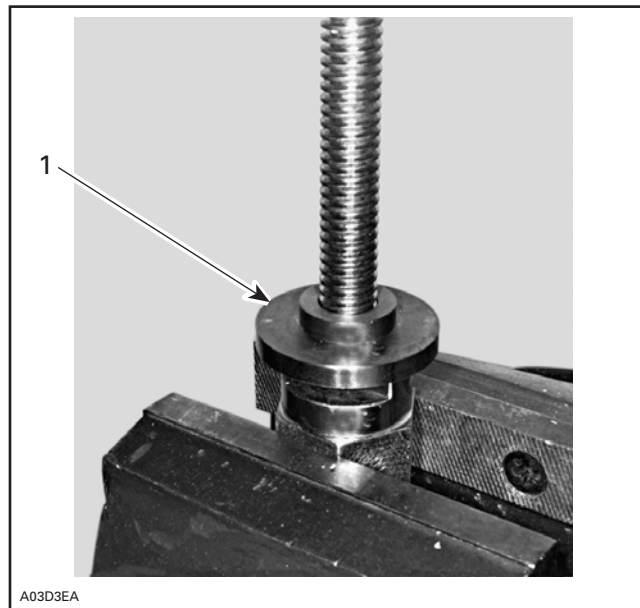

1. Support guide

Install sliding half then a second support guide. These support guides will prevent bushing damages.

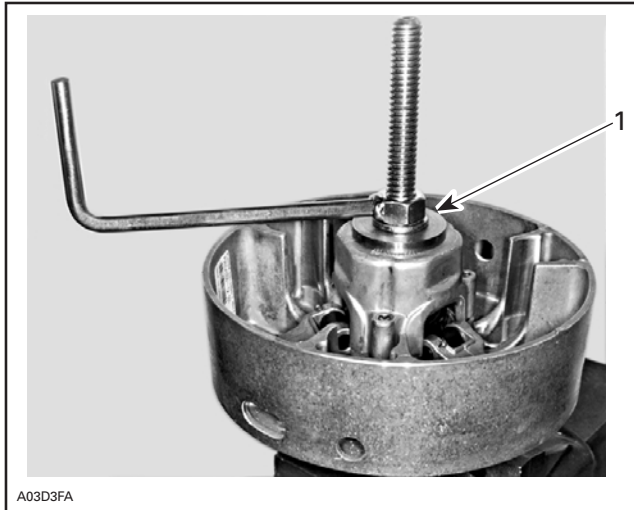

1. Support guide

Remove 3 Allen screws retaining spring cover then unscrew compressor.

CLEANING

5,6, Fixed and Sliding Half

Clean pulley faces and shaft with fine steel wool and dry cloth.

5, Fixed Half and Crankshaft End

Parts must be at room temperature before cleaning.

Using a paper towel with cleaning solvent, clean crankshaft tapered end and the taper inside the fixed half of the drive pulley, crankshaft threads and retaining screw threads.

WARNING

This procedure must be performed in a well-ventilated area.

CAUTION: Avoid contact between cleaner and crankshaft seal because damage may occur.

Remove all hardened oil deposits that have baked on crankshaft and pulley tapered surfaces with coarse or medium steel wool and/or sand paper no. 600.

CAUTION: Do not use any other type of abrasive.

Reclean mounting surfaces with paper towel and cleaning solvent.

Wipe off the mounting surfaces with a clean and dry paper towel.

CAUTION: Mounting surfaces must be free of any oil, cleaner or towel residue.

7,20, Bushing

Only use petrol base cleaner when cleaning bushings.

CAUTION: Do not use acetone to clean bushing.

INSPECTION

Drive pulley should be inspected annually.

16,17, Thrust Washer and Roller

Check roller for roundness of external diameter. Check thrust washer for thickness wear. Replace as required.

CAUTION: Ensure rollers are in good condition. Replace as required.

9,12, Fitting Bolt Ass'y and Flanged Bushing

Check for wear, replace as required.

24,25, O-Ring and Slider Shoe

Check if O-rings are cracked, cut or crushed. Replace as required.

Check slider shoes for wear. Replace if groove is not apparent on top.

5,29, Fixed Half and Governor Cup

Inspect splines and free play between both parts. Maximum free play is 0.5 mm (.020 in) measured at calibration screw radius. Replace if required.

7,20, Sliding Half and Spring Cover Bushing

Visually inspect coating. Replace if worn.

Sliding Half Bushing Replacement

This bushing is not replacable. If worn out, replace sliding half ass'y.

Section 05 TRANSMISSION

Subsection 03 (DRIVE PULLEY)

Spring Cover Bushing Replacement

Under normal use there is no need to replace this bushing.

Mount compressor (P/N 529 035 524) in a vise.

Use tools (P/N 529 031 300 and 529 031 200) to remove old bushing.

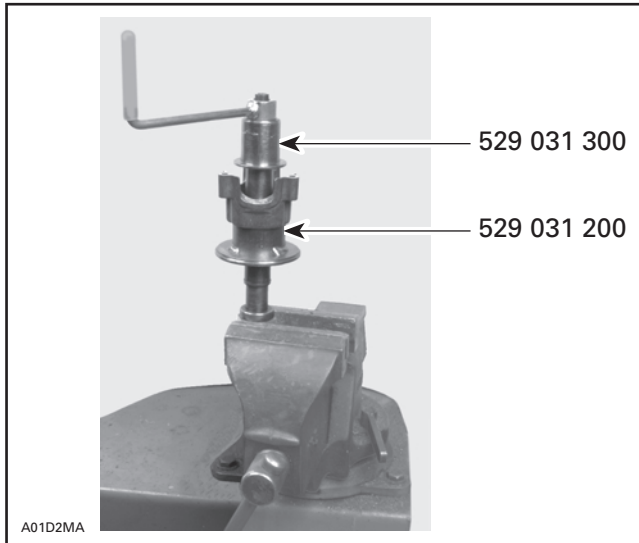

CAUTION: Bushing must be bonded with retaining compound.

Apply retaining compound Loctite 609 outside of bushing then press it down to counterbore from outside end.

CAUTION: Insert bushing from sliding half side (inner side) of spring cover.

ASSEMBLY

NOTE: This drive pulley is lubrication free. Do not lubricate any component.

1,2,3, Screw, Ring Gear and Loctite 271

Apply Loctite 271 (P/N 413 702 900) on threads and then torque to 27 N•m (20 lbf•ft).

26,27,28, Calibration Screw, Washer and Locking Nut

When installing calibration screw, make sure to install washer as shown.

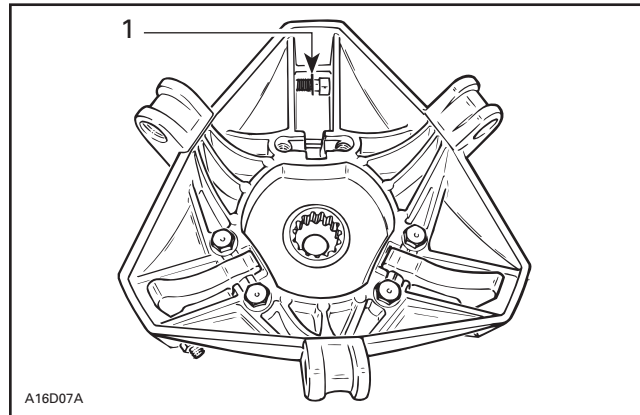

1. Washer

Torque locking nut to 10 N•m (89 lbf•in).

15, Pin

Always use the same type of pin as originally installed when servicing. Different types have different weights for calibration purpose. Refer to TECHNICAL DATA.

21,22,23, Screw, Dowel Tube and Ramp

Insert dowel tube from chamfered side. Make sure ramp is centered on dowel tube.

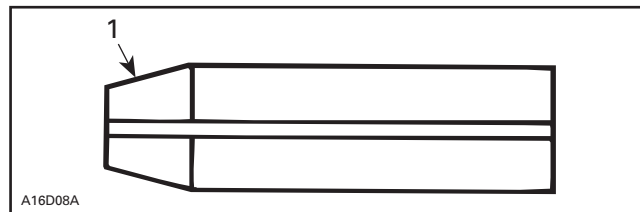

1. Chamfered side

Position dowel tube split at the illustrated angle.

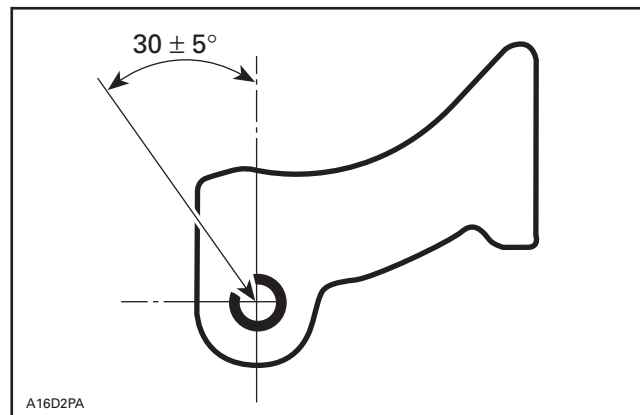

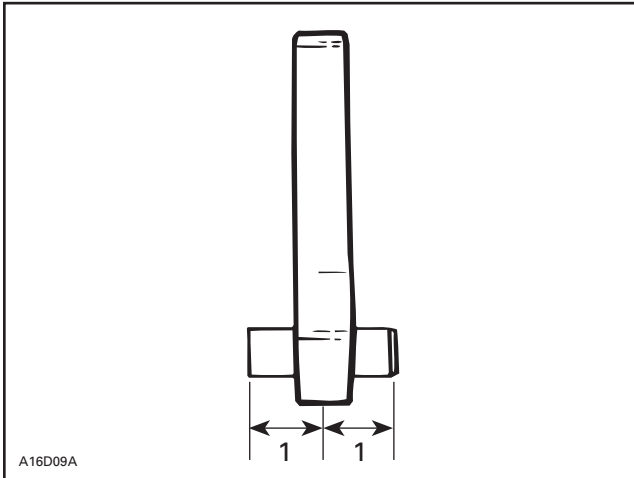

1. Equal distance

Torque screws to 10 N•m (89 lbf•in).

9,11,13,14, Screw, Lever Ass’y, Nut and Cotter Pin

Always install lever assemblies so that cotter pins are on the shown side. Install cotter pin head on top when lever is sat at bottom of sliding half. Bend cotter pin ends to sit perfectly against lever.

⚠ WARNING

Whenever replacing centrifugal levers, always replace all 3 at the same time. Otherwise, drive pulley misbalancing will occur because of levers difference.

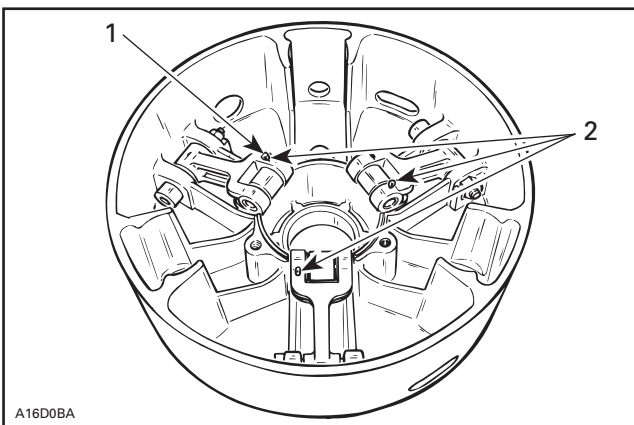

1. Head on top
 2. All on the same side

CAUTION: Lever assemblies must be installed so that cotter pins are on the same side.

Torque nuts to 12 N•m (106 lbf•in).

CAUTION: Lever ass’y and rollers must move easily after installation.

5,6,18,19, Fixed Half, Sliding Half, Spring, Spring Cover and Screw

To install spring cover, use spring compressor (P/N 529 035 524).

Assemble fixed and sliding halves. Note that fixed halves have different cone angle. Match cone angle with crankshaft.

Lift sliding half against spring cover and align spring cover arrow with sliding half mark.

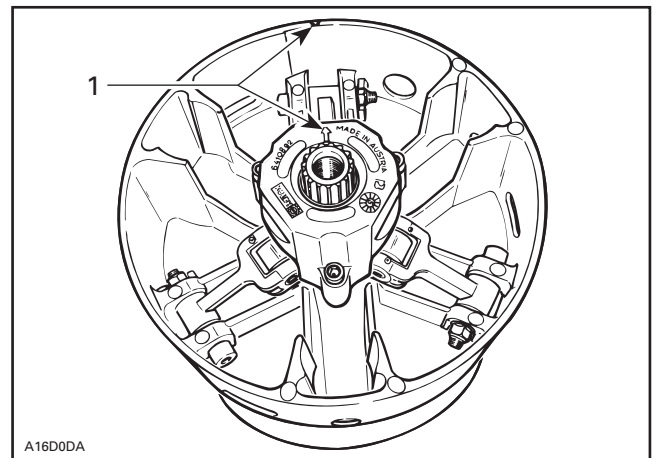

1. Align

Install and torque screws to 13 N•m (115 lbf•in).

6,25,29, Sliding Half, Slider Shoe and Governor Cup

To install governor cup, use following tool:

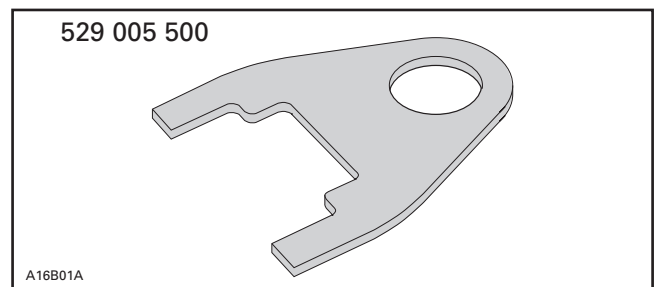

Insert spring and slider shoes into governor cup so that groove in each slider shoe is vertical to properly slide in guides.

CAUTION: Make sure O-rings are installed on slider shoes and that grooves are positioned vertically.

Section 05 TRANSMISSION

Subsection 03 (DRIVE PULLEY)

Install fork (P/N 529 005 500) into slider shoe grooves to maintain them for governor cup installation. Proceed on 3 set of slider shoes.

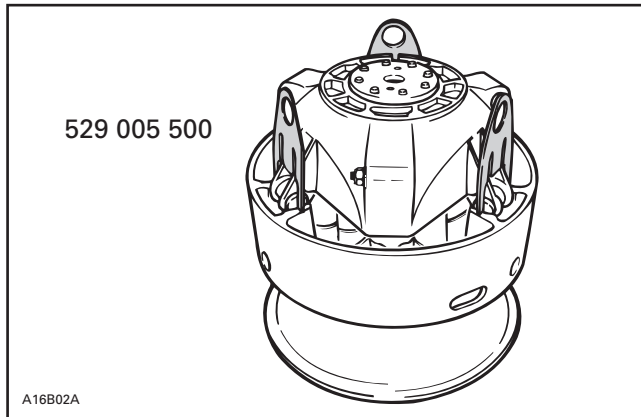

Make sure to align governor cup arrow with sliding half and fixed half mark.

NOTE: If fixed half has no mark, align governor cup mark with segment no. 1 of inner half. Segments are identified on engine side.

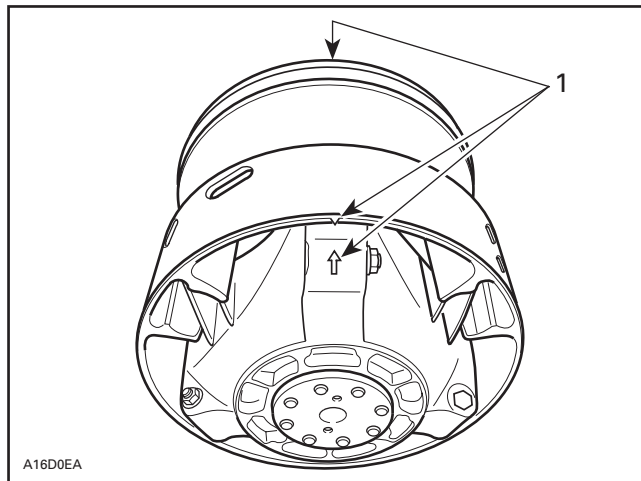

1. *Align*

Carefully slide governor cup into sliding half. Align mark of governor cup with mark of fixed half.

Remove forks and push governor cup so that its splines engage with fixed half shaft splines.

CAUTION: Make sure splines of both parts are fully engaged.

INSTALLATION

⚠ WARNING

Do not apply anti-seize or any lubricant on crankshaft and drive pulley tapers.

⚠ WARNING

Never use any type of impact wrench at drive pulley removal and installation.

Clean mounting surfaces as described in **CLEANING** above.

Drive Pulley Ass'y

The following installation procedure must be strictly adhered to.

Install drive pulley on crankshaft extension.

Install a new conical spring washer with its concave side towards drive pulley then install screw.

⚠ WARNING

Never substitute conical spring washer and/or screw with jobber ones. Always use Bombardier genuine parts for this particular case.

Use holder. See removal procedure.

Torque screw to 90 to 100 N•m (66 to 74 lbf•ft).

Install drive belt and guard.

Raise the rear of the vehicle and support it with a mechanical stand.

⚠ WARNING

Ensure that the track is free of particles which could be thrown out while track is rotating. Keep hands, tools, feet and clothing clear of track. Ensure nobody is standing near the vehicle.

Accelerate the vehicle at low speed (maximum 30 km/h (20 MPH) and apply the brake, repeat 5 times.

Recheck the torque of 90 to 100 N•m (66 to 74 lbf•ft).

⚠ WARNING

After 10 hours of operation the transmission system of the vehicle must be inspected to ensure the retaining screw is properly torqued.

DRIVE PULLEY ADJUSTMENT

The drive pulley is factory calibrated to transmit maximum engine power at a predefined RPM. Factors such as ambient temperature, altitude or surface condition may vary this critical engine RPM thus affecting snowmobile efficiency.

This adjustable drive pulley allows setting maximum engine RPM in the vehicle to maintain maximum power.

Calibration screws should be adjusted so that actual maximum engine RPM in vehicle matches with the maximum horsepower RPM given in TECHNICAL DATA.

NOTE: Use precision digital tachometer for engine RPM adjustment.

NOTE: The adjustment has an effect on high RPM only.

To adjust, modify ramp end position by turning calibration screws.

26,28,29, Calibration Screw, Locking Nut and Governor Cup

Calibration screw has a notch on top of its head.

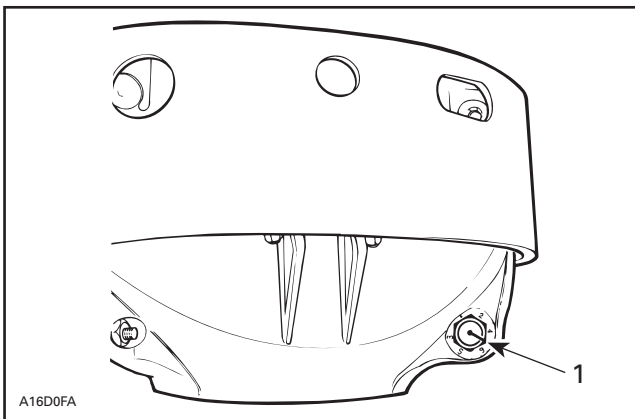

1. Notch

Governor cup has 6 positions numbered 2 to 6. Note that in position 1 there is no stamped number (due to its location on casting).

See TECHNICAL DATA for original setting.

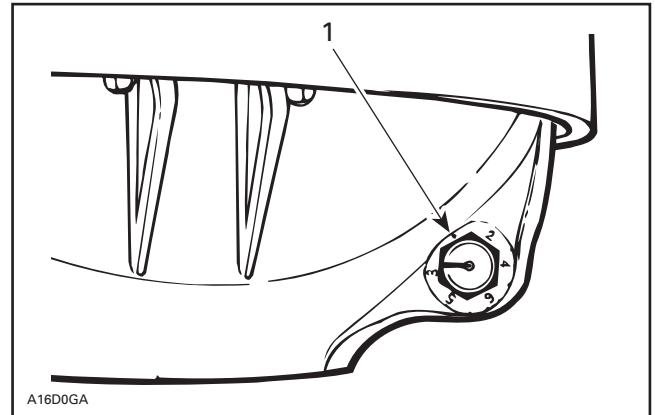

1. Position 1 (not numbered)

Each number modifies maximum engine RPM by about 200 RPM.

Lower numbers decrease engine RPM in steps of 200 RPM and higher numbers increase it in steps of 200 RPM.

Example:

Calibration screw is set at position 3 and is changed to position 5. So maximum engine RPM is increased by about 400 RPM.

To Adjust:

Just loosen locking nut enough to pull calibration screw **partially** out and adjust to desired position. Do not completely remove the locking nut. Torque locking nuts to 10 N•m (89 lbf•in).

CAUTION: Do not completely remove calibration screw otherwise its inside washer will fall off.

CAUTION: Always adjust all 3 calibration screws and make sure they are all set at the same number.

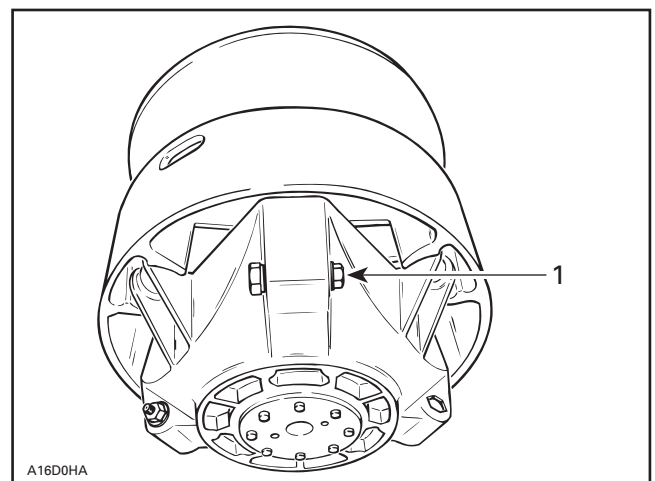

1. Loosen just enough to permit rotating of calibration screw

DRIVEN PULLEY

Tundra R

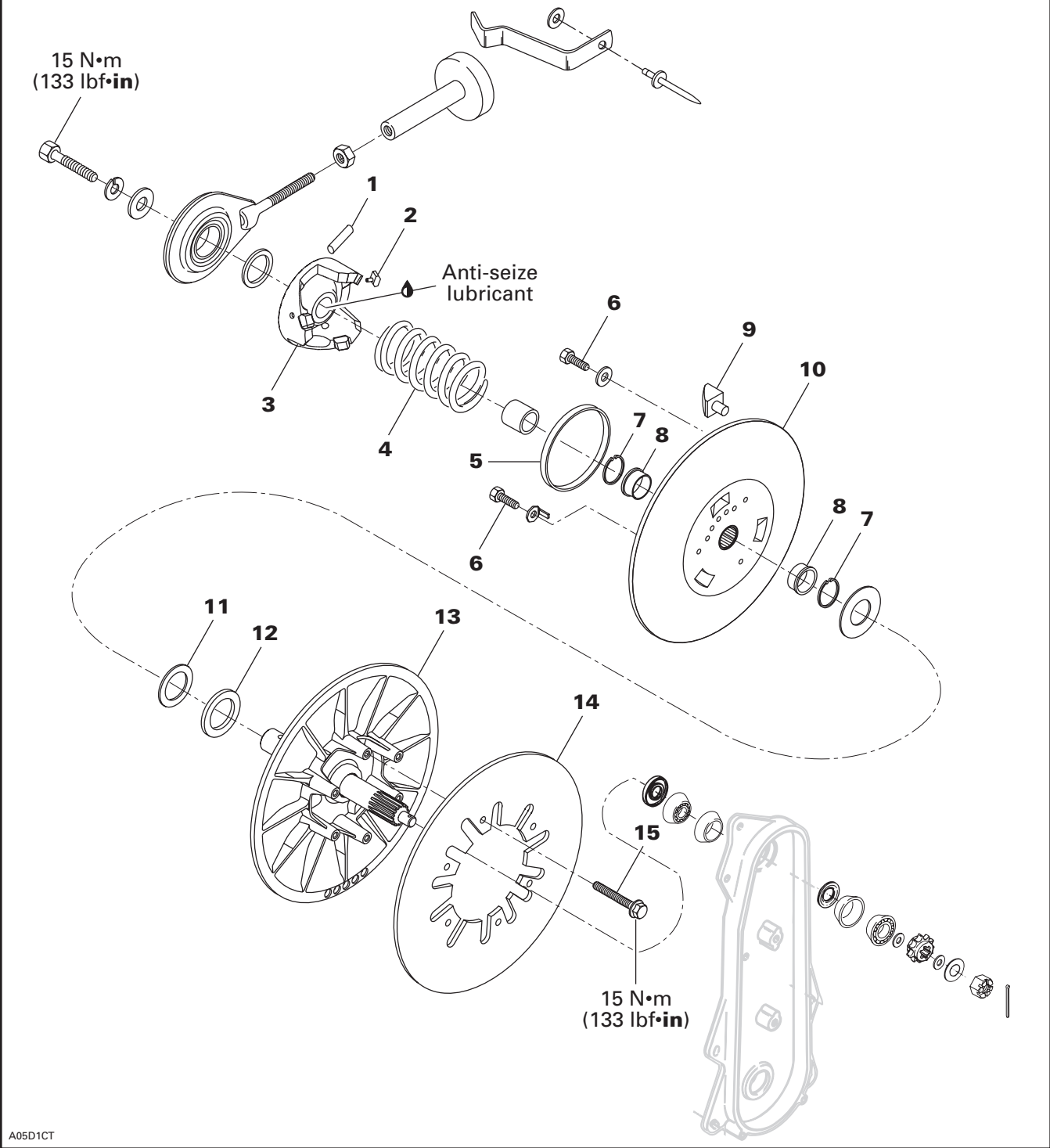

A05D1CT

Section 05 TRANSMISSION

Subsection 04 (DRIVEN PULLEY)

NOTE: Driven pulley components (support, cam, shoes, etc.) can be serviced without removing the whole driven pulley from chaincase. Refer to the following procedures but neither remove brake caliper nor open chaincase for those cases.

REMOVAL

To remove driven pulley from chaincase, follow this procedure.

Remove guard and drive belt from vehicle.

Remove brake support from chaincase with brake ass'y.

Free countershaft support from support clamp.

Chaincase

Open chaincase and drain oil. Unlock and remove upper sprocket.

The following is required to have enough space to remove driven pulley from chaincase:

Loosen steering column upper retaining screws.

Disconnect carburetor boots from intake manifold and air intake silencer.

Disconnect impulse hose from engine.

Disconnect oil injection supply line at injection pump and plug line to prevent draining.

Remove screws retaining rear engine support to chassis.

Tip engine forward just enough to allow driven pulley removal from chaincase. Block in this position.

NOTE: In some cases, chaincase retaining screws might have to be loosened to allow pivoting of chaincase. In this case, note position of alignment shims. In addition, air intake silencer and oil injection reservoir might have to be slightly moved to get enough space to pull driven pulley.

Remove bearing cone.

Knock driven pulley shaft with a plastic hammer and pull driven pulley out.

DISASSEMBLY

To disassemble driven pulley, driven pulley spring compressor (P/N 529 035 300) must be used. See following procedure.

Position stop nut 13 mm (1/2 in) from threaded rod end, as shown in the next photo.

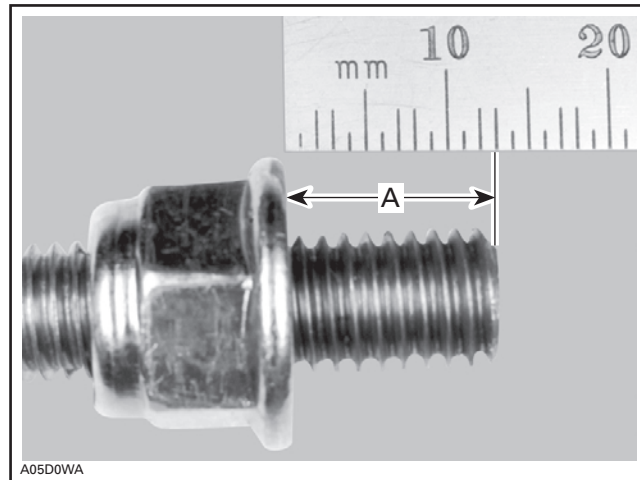

A. 13 mm (1/2 in)

Install driven pulley spring compressor (P/N 529 035 300). Fully tighten the 13 mm (1/2 in) exposed threads in driven pulley. Tighten stop nut. Tighten tool knob to compress spring then remove roll pin **no. 2**.

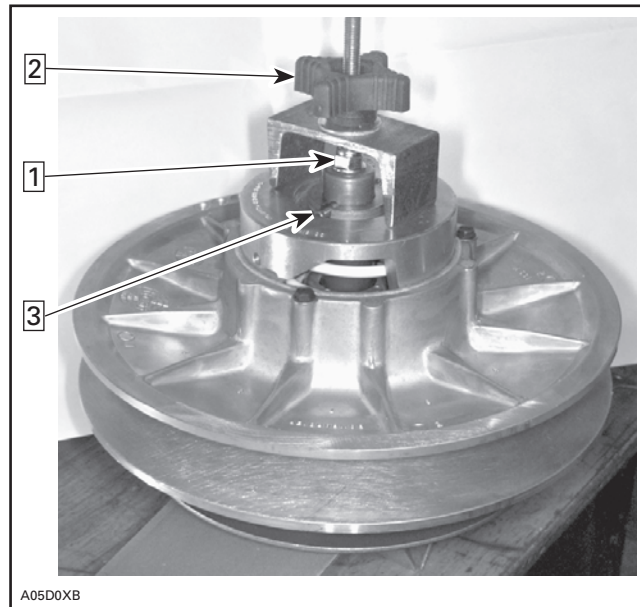

Step **1**: Tighten stop nut

Step **2**: Tighten knob to compress spring

Step **3**: Remove roll pin

Once roll pin has been removed, loosen knob until spring pressure is completely released.

⚠ WARNING

To avoid injuries always hold stop nut with a key when loosening knob, as shown in the next photo.

Section 05 TRANSMISSION
Subsection 04 (DRIVEN PULLEY)

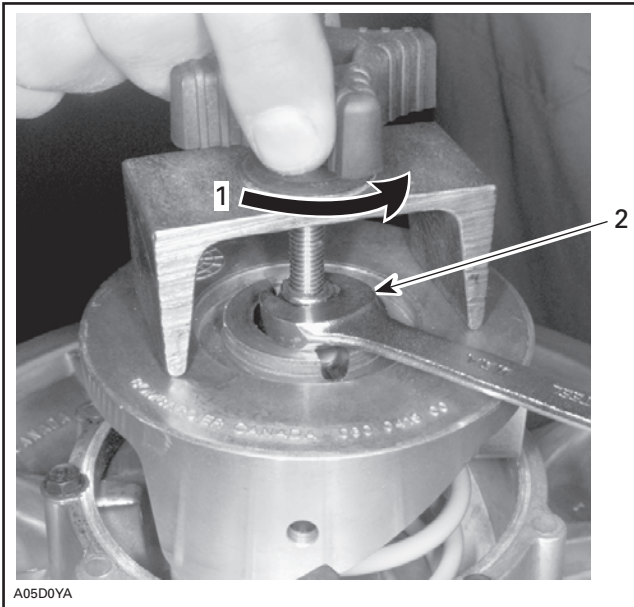

1. When loosening knob
2. Hold stop nut with a key

Remove tool and cam no. 3. Remove spring no. 4 and sliding half no. 10.

8, Sliding Half Small Bushing

To remove a worn bushing no. 8, use a screwdriver and pull out circlip no. 7.

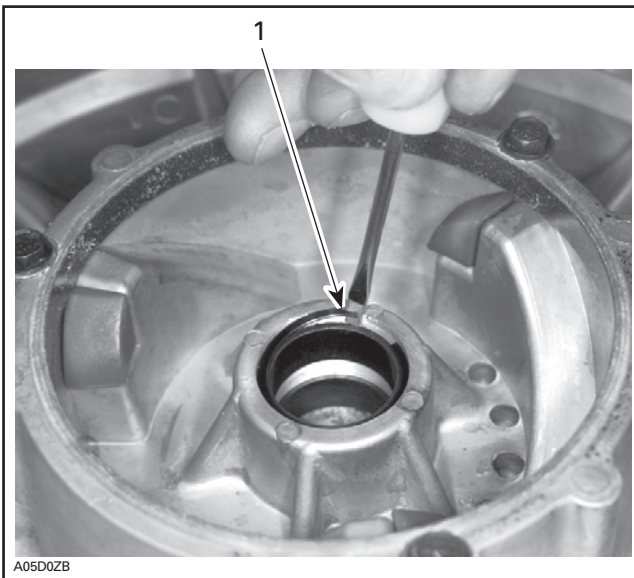

1. Remove circlip

Reverse pulley half no. 10 then remove bushing using a punch, as shown in the next photo.

CAUTION: Small bushings will be damaged at removal. Always replace with new ones.



5, Large Bushing

Remove 3 screws no. 6 with washers and pry bushing no. 5 out.

INSPECTION

2,9, Slider Shoe

Black slider shoe = forward

Red slider shoe = reverse

Check cam slider shoes for wear. Replace when inside edge thickness of cam slider shoe slope base is 1 mm (.039 in) or less.

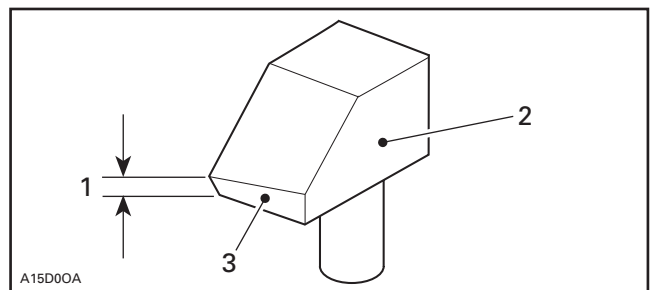

1. Measure thickness of slope base here
2. Sliding pulley side
3. Slope base

Section 05 TRANSMISSION

Subsection 04 (DRIVEN PULLEY)

ASSEMBLY

Assemble driven pulley components by reversing the disassembly procedure except for the following:

8, Bushing

Clean mounting surfaces with Loctite Safety Solvent. Using a press and Rotary valve shaft seal pusher (P/N 420 876 512), install bushing as shown in the next photo.

CAUTION: To avoid bushing damage, use extreme caution when inserting new bushings.



2,9, Slider Shoe

When replacing slider shoes, always install a new set (3 shoes) to maintain equal pressure on the cam.

Install slider shoes as per following photo. Red slider shoes are being used for reverse and black ones for forward.

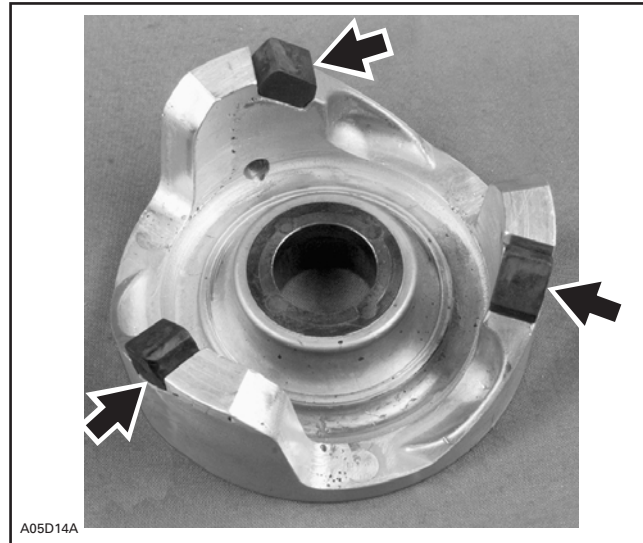

BLACK SLIDER SHOES ON CAM

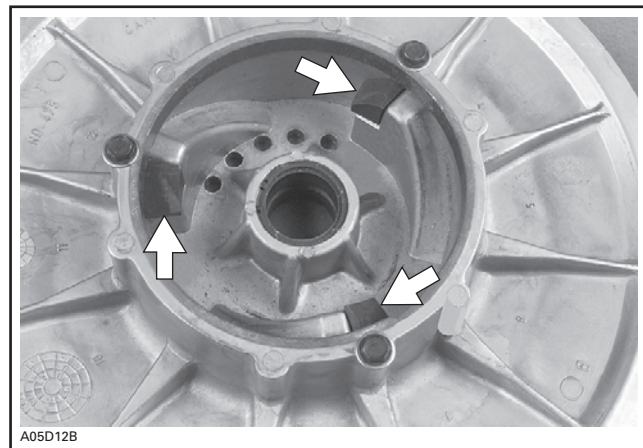

RED SLIDER SHOES ON PULLEY HALF

2,4,5, Roller Pin, Outer Cam and Spring

Insert spring in adjusting hole no. 3 into sliding half, as illustrated.

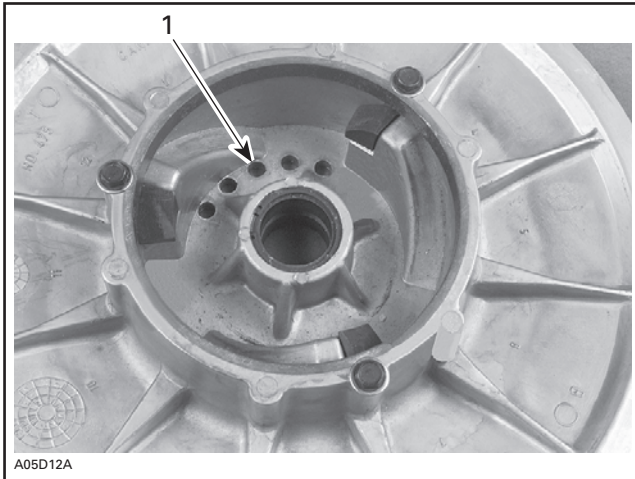

1. Adjusting hole no. 3

Insert other spring end in cam. Mount driven pulley spring compressor (P/N 529 035 300) as in **Disassembly** procedure.

Push cam all the way in then install roll pin coated with anti-seize lubricant (P/N 413 701 000).

13,14,15, Fixed Pulley Half, Brake Disc and Screw

Install brake disc on fixed pulley half and torque screws to 15 N•m (115 lbf•in).

INSTALLATION

Follow installation procedure for Tundra driven pulley at beginning of this subsection.

ADJUSTMENT

11,12, Shim

NOTE: The following adjustment must be performed with a new drive belt.

For best performance, particularly at starting, top of drive belt should be flush with top of driven pulley halves.

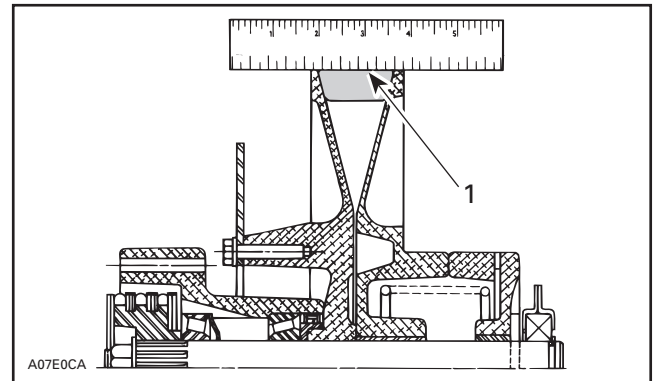

TYPICAL

1. Belt flush with the top of the pulley halves

Shim(s) **no. 11** and **no. 12** provide belt height adjustment between pulley halves. Adding shims will lower the belt in driven pulley, while removing shims will raise the belt. Adjust properly.

Pulley Alignment and Drive Belt Deflection

Refer to PULLEY DISTANCE AND ALIGNMENT and DRIVE BELT to perform adjustments.

CAUTION: Drive belt and pulley adjustments must always be checked whenever pulleys have been removed, replaced or disassembled.

Section 05 TRANSMISSION

Subsection 04 (DRIVEN PULLEY)

THRUST BUSHING

Skandic WT/SWT/WT LC

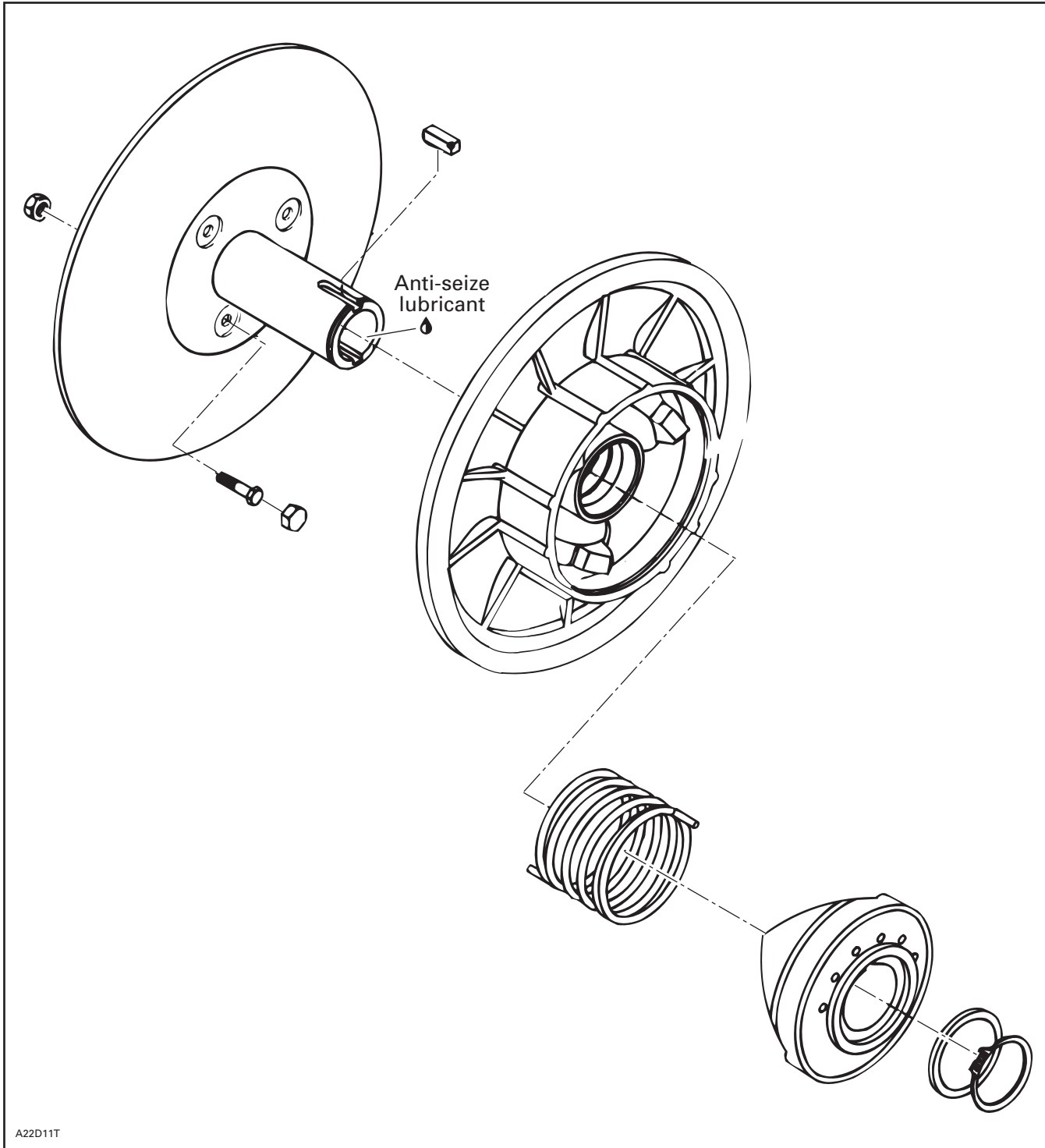

LPV 27

Skandic LT

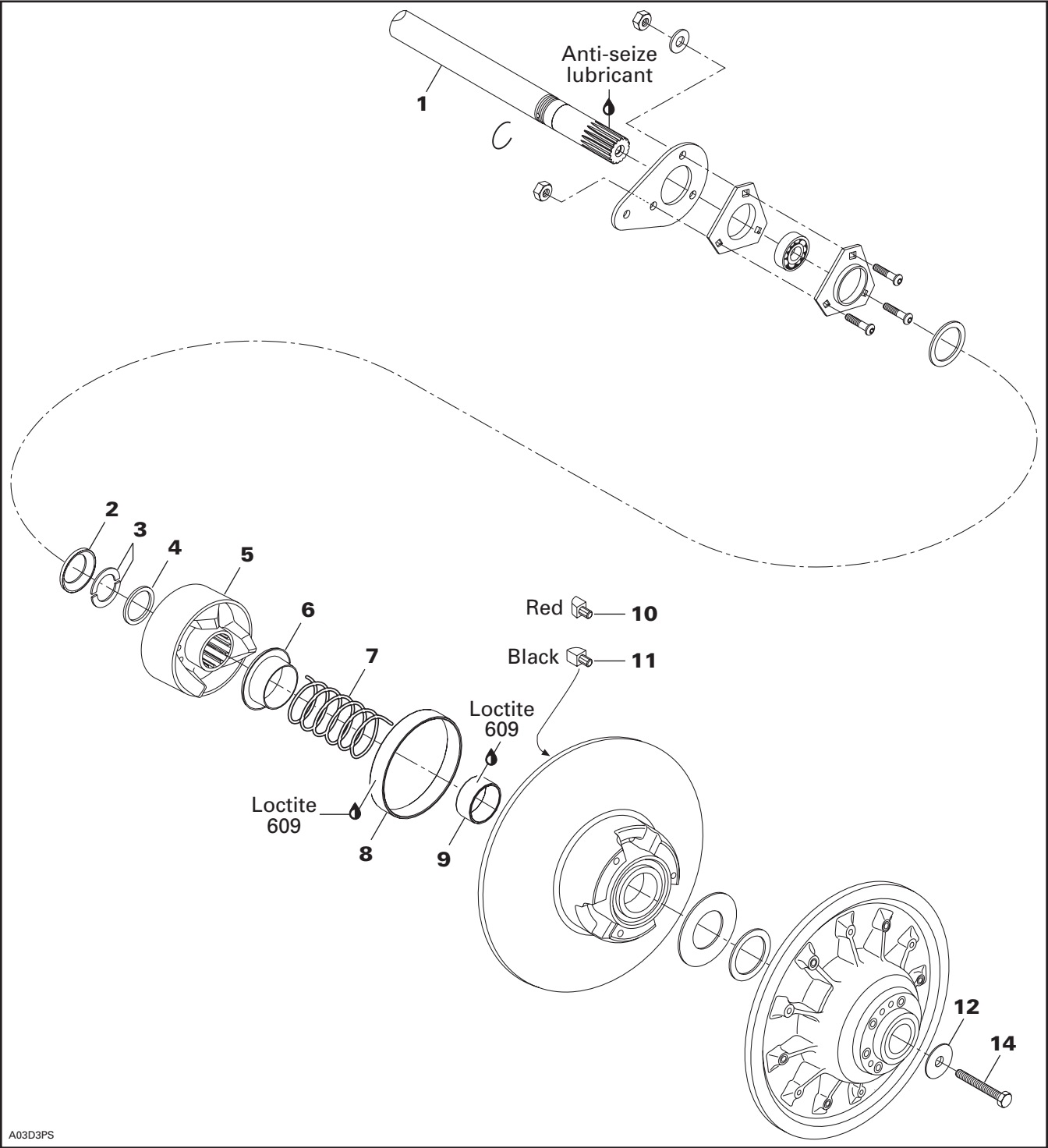

Section 05 TRANSMISSION

Subsection 04 (DRIVEN PULLEY)

DISASSEMBLY

Use spring compressor (P/N 529 035 524).



TYPICAL

Remove half keys **no. 3** and spacer **no. 4** to disassemble the outer cam and the 2 pulley halves.

⚠ WARNING

Driven pulley cam is spring loaded, use above mentioned tool.

INSPECTION

Replace bushing(s) if worn more than specified.

DRIVEN PULLEY BUSHING WEAR LIMIT mm (in)	
Small bushing	38.30 (1.508)
Large bushing	108.2 (4.260)

10,11, Slider Shoe

Black slider shoe = forward

Red slider shoe = reverse

Check cam slider shoes for wear. Replace when inside edge thickness of cam slider shoe slope base is 1 mm (.039 in) or less.

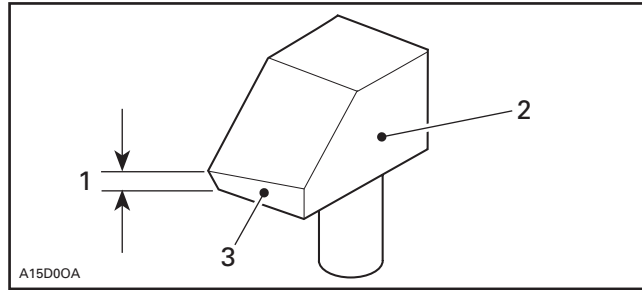

1. Measure thickness of slope base here
2. Sliding pulley side
3. Slope base

Bushing Replacement

Large Bushing

Remove Allen screws if applicable. Heat to break Loctite bond.

Install support plate included in tool (P/N 529 031 100) inside sliding half.

Place extractor (P/N 529 035 575) below bushing.

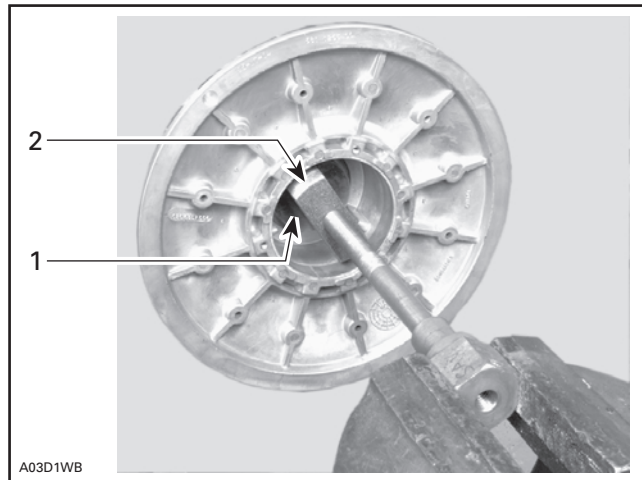

TYPICAL

1. Support plate
2. Extractor

Mount screw head of new puller (P/N 529 035 524) in a vise.

Turn pulley half by hand to extract old bushing.

Before bushing installation, file sliding half bore to remove burrs from crimping areas.

Coat bushing outside diameter with Loctite 609 (P/N 413 703 100). Place new bushing on sliding half and slightly tap to engage squarely the bushing in the sliding.

ASSEMBLY

10,11, Cam Slider Shoe

When replacing slider shoes, always install a new set (3 shoes) to maintain equal pressure on the cam. Install slider shoes as per following photo. Red slider shoes are being used for reverse and black ones for forward.

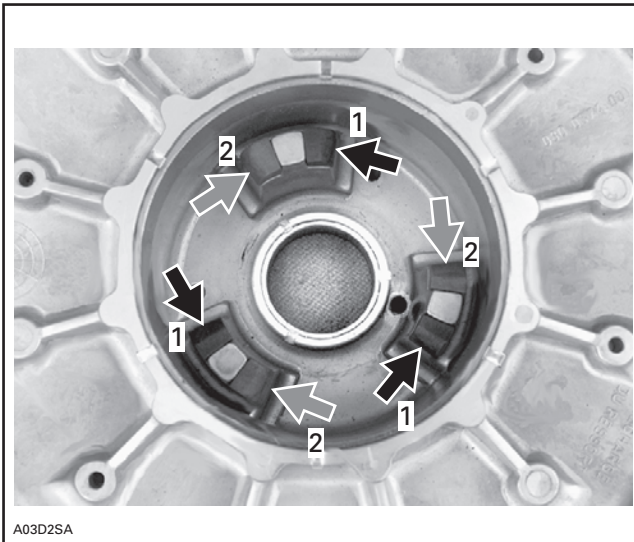

1. BLACK slider shoe
2. RED slider shoe

Assemble driven pulley components by reversing the disassembly procedure.

5,6,7, Cam, Guard and Spring

Make sure to install proper cam. Refer to TECHNICAL DATA.

Cam angle is identified on cam.

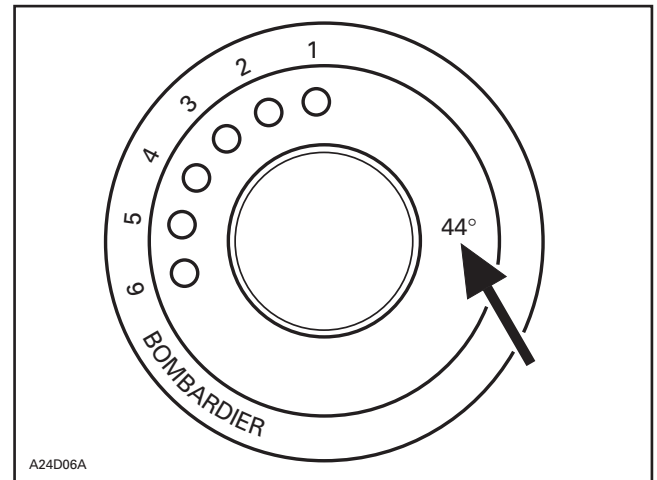

Position guard no. 6 in cam no. 5 then insert spring in adjusting hole no. 3 (mid-hole) into outer cam. Compress outer cam using spring compressor (P/N 529 035 524).

Install spacer no. 4 then secure outer cam with half keys no. 3, as shown in the next photo.

CAUTION: Ensure that half keys are properly inserted into shaft groove and that spacer recess is facing half keys.

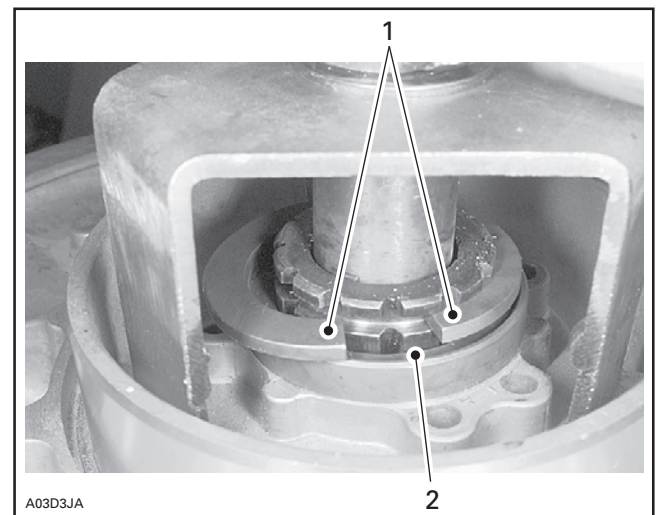

1. Half keys inserted into shaft groove
2. Spacer recess facing half keys

Section 05 TRANSMISSION

Subsection 04 (DRIVEN PULLEY)

INSTALLATION

1, Countershaft

CAUTION: Always apply anti-seize lubricant (P/N 413 701 000) on the countershaft before final pulley installation.

Make sure that spacer no. 2 is on countershaft before installing driven pulley. Note also that washer shoulder is facing driven pulley.

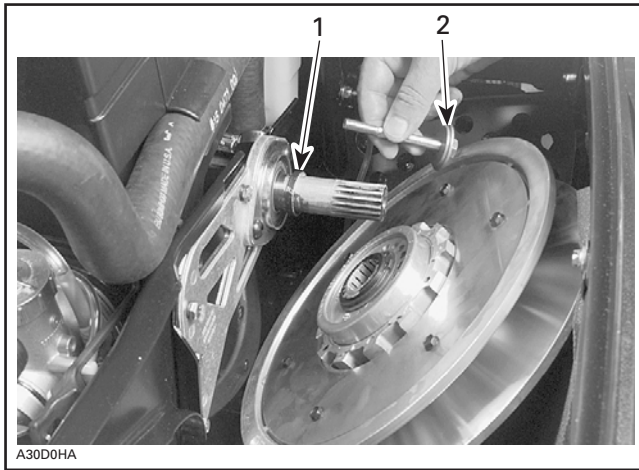

TYPICAL

1. Spacer
2. Shoulder on this side

Should installation procedure be required, refer to BRAKE then look for **Brake Disc and Countershaft Bearing Adjustment**.

Reinstall the pulley on the countershaft by reversing the removal procedure.

14, Pulley Retaining Screw

Torque to 25 N•m (18 lbf•ft).

ADJUSTMENT

Pulley Alignment and Drive Belt Deflection

Refer to PULLEY DISTANCE AND ALIGNMENT and DRIVE BELT to perform adjustments.

CAUTION: Drive belt and pulley adjustments must always be checked whenever pulleys have been removed, replaced or disassembled.

PULLEY DISTANCE AND ALIGNMENT

GENERAL

The pulley distance we will refer to in this section, is the space separating the drive and driven pulley outside diameters (Z measurement).

This basic distance is provided as an assembly guide and indicates the dimensions between which satisfactory belt deflection will be obtained.

Both pulley distance adjustment and pulley alignment must be carried out to ensure the highest efficiency of the transmission system. Furthermore, optimum drive belt operation and minimal wear will be obtained only with proper pulley alignment.

CAUTION: Before checking pulley adjustment, the rear suspension must be mounted on the vehicle and track tension/alignment must be done. Always check pulley adjustment after suspension is adjusted.

WARNING

Failure to correctly perform pulley alignment may cause the vehicle to creep forward at idle.

All pulley alignment specifications refer to:

X = Distance between straight bar and drive pulley fixed half edge, **measured between pulleys.**

Y = Distance between straight bar and drive pulley fixed half edge, **measured at the end of straight bar.**

Z = Distance between outside diameter of pulleys.

GENERAL PROCEDURE

Remove guard.

Tundra R

Use driven pulley opening tool (P/N 529 034 200).

Skandic LT

Use driven pulley opening tool (P/N 529 035 501).

All Models

Remove drive belt.

Insert a straight bar 9.5 mm (.375 in) square, 48 cm (19 in) long or the proper alignment bar into the opened driven pulley.

Measuring Procedure

Using Straight Bar

Always measure distances X and Y from the farther straight bar side (including its thickness to the fixed half edge).

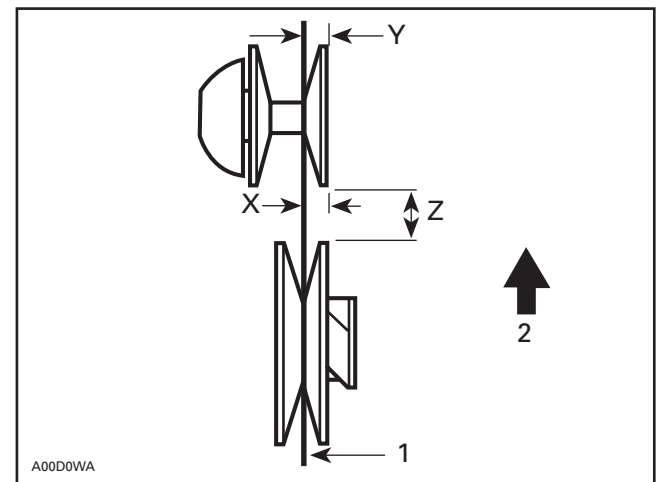

1. Straight bar
2. Front of vehicle

The distance Y **must** exceed distance X to compensate for the twist due to the engine torque.

Mean Value Procedure and Quick Alignment and Distance Check

Alignment bar tabs must fully contact fixed half of drive pulley.

Pulley distance is correct when tab contacts both pulley halves.

Refer to chart on next page for proper alignment bar.

Section 05 TRANSMISSION

Subsection 05 (PULLEY DISTANCE AND ALIGNMENT)

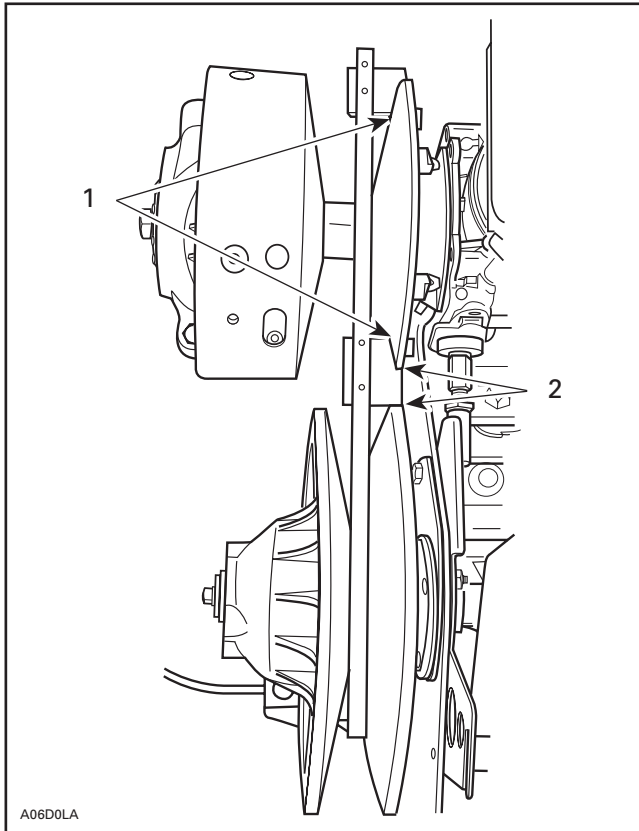

TYPICAL

1. Contact (alignment)
2. Contact (distance)

Tundra R Only

Bottom of alignment bar must not seat on shaft nor fixed half shoulder and shim(s).

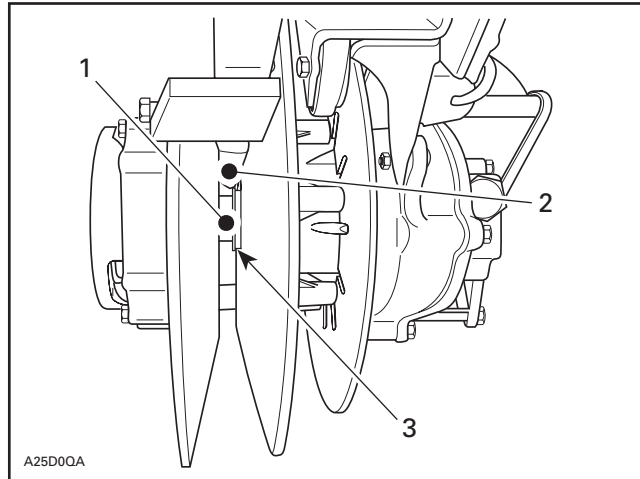

TYPICAL

1. Shaft
2. Alignment bar
3. Fixed half shoulder and shim(s)

Drive Belt Height

NOTE: When pulley distance and alignment are adjusted to specifications, refer to DRIVE BELT to adjust drive belt height.

CAUTION: This section deals mainly with adjustment procedures. For complete assembly requirements, refer to the proper ENGINE or TRANSMISSION installation section.

PULLEY ALIGNMENT AND DISTANCE SPECIFICATIONS CHART

MODELS	PULLEY DISTANCE	OFFSET		ALIGNMENT BAR ① P/N
	Z	X	Y-X	
	± 0.50 mm (.020 in)	± 0.50 mm (.020 in)	± 0.5 mm (.020 in)	
TUNDRA R	37.0 (1.457)	36.0 (1.417)	1.0 (.039)	529 026 900
SKANDIC LT	39.0 ± 0.75 (1.535 ± .030)	37.0 ± 0.75 (1.457 ± .030)	0.75 to 2.25 (.030 to .086)	—
SKANDIC WT/SWT/WT LC	32.3 ± 0.75 (1.272 ± .030)	35.0 ± 0.75 (1.380 ± .030)	0.75 to 2.25 (.030 to .086)	529 035 545

① Alignment bars have been made according to pulley alignment mean values. However, they do not take into account allowed tolerances for alignment specifications. They are used as GO/NOGO gauges for quick alignment and pulley distance check and as reference to reach alignment nominal values.

Pulley Distance Adjustment Method

Tundra R

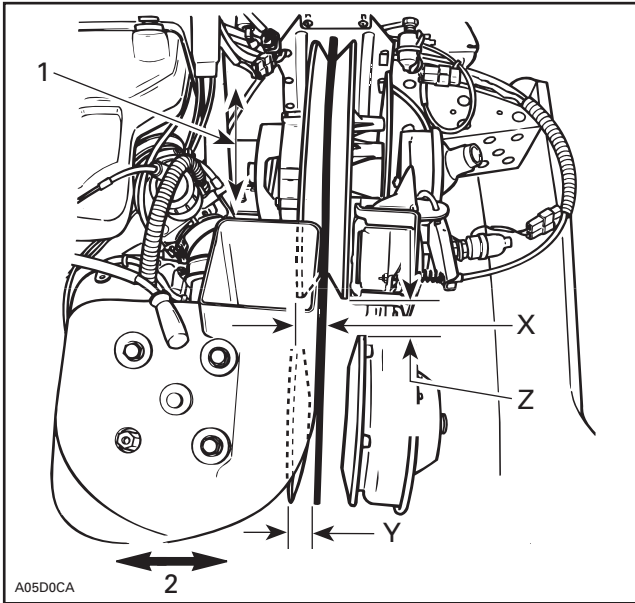

- 1. Driven pulley movement
- 2. Engine movement

CAUTION: The rear suspension must be mounted on the vehicle and track tension and alignment must be done to provide the right frame width.

Loosen the 4 chaincase retaining bolts, unlock and raise pulley support.

Move chaincase to obtain specific adjustment and adjust driven pulley support length accordingly (light contact).

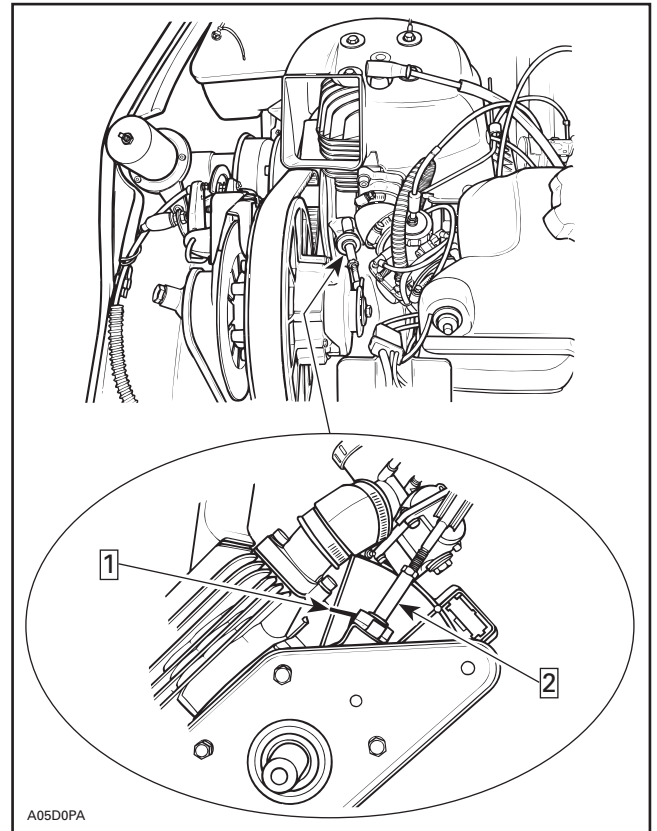

- Step 1: Push and hold
- Step 2: Raise support

Skandic LT

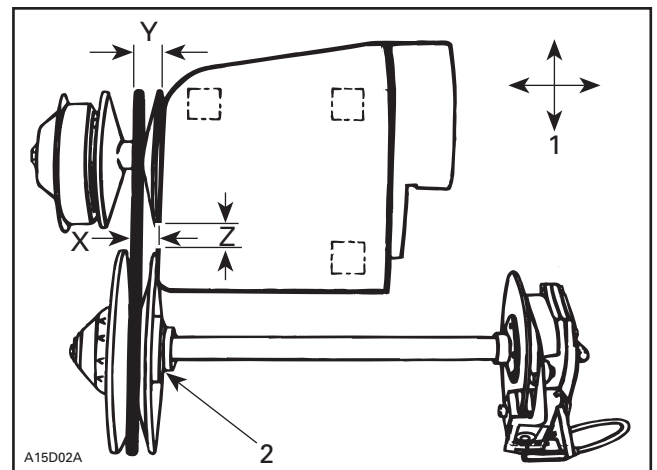

TYPICAL

- 1. Engine movement
- 2. Contact

Section 05 TRANSMISSION

Subsection 05 (PULLEY DISTANCE AND ALIGNMENT)

NOTE: Prior to performing pulley adjustment, loosen torque rod nut to allow engine movement. Engine supports have tendency to stick to frame, work engine loose prior to aligning.

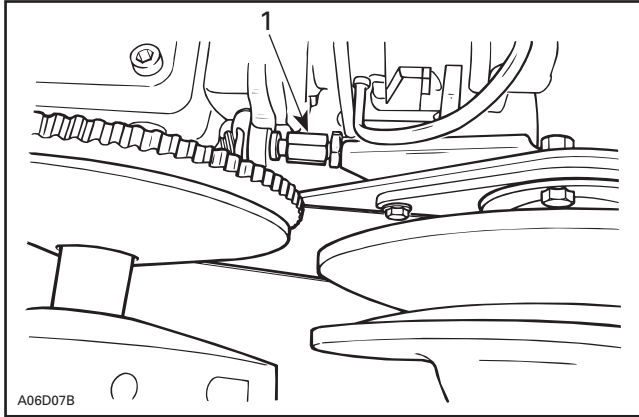

1. Loosen

Engine Movement

The engine support has slotted mounting holes. Move engine to obtain specified distance between pulleys.

Skandic WT/SWT/WT LC

Driven Pulley Movement

Loosen gearbox retaining screws and move gearbox accordingly.

Retighten screws.

Pulley Alignment Method

Tundra R

Engine Movement

Loosen the support retaining bolts.

Move the engine to obtain specified pulley alignment, torque engine support bolts to 55 N•m (41 lbf•ft) and remove engine support positioner.

Driven Pulley Movement

Shims can be mounted between chaincase and frame. Use shim (P/N 504 039 800), 0.53 mm (.021 in) thick.

Skandic LT

When engine slotted mounting holes do not allow to set proper pulley offset X, adjust with shims (P/N 504 108 200) between pulley and countershaft bearing support (pulley pushed toward brake disc).

Engine Movement

Loosen the 4 bolts retaining engine support to the frame. Position engine to obtain the specified alignment.

NOTE: After alignment, adjust torque rod so it slightly contacts stopper plate. Do not over tighten, it will disalign pulleys.

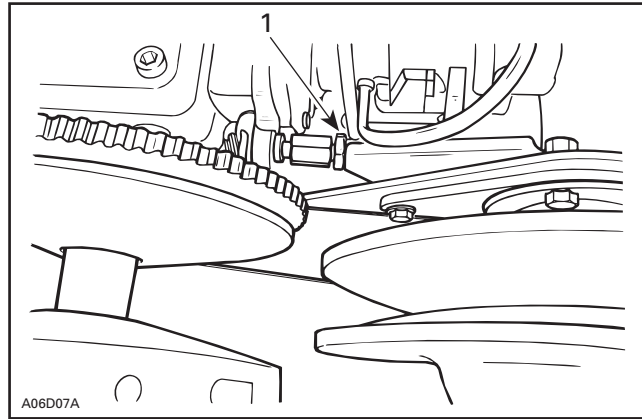

1. Retighten

Skandic WT/SWT/WT LC

Driven Pulley Movement

Loosen gearbox retaining screws.

Install or remove shims accordingly.

Retighten screws.

BRAKE

MECHANICAL BRAKE

Tundra R

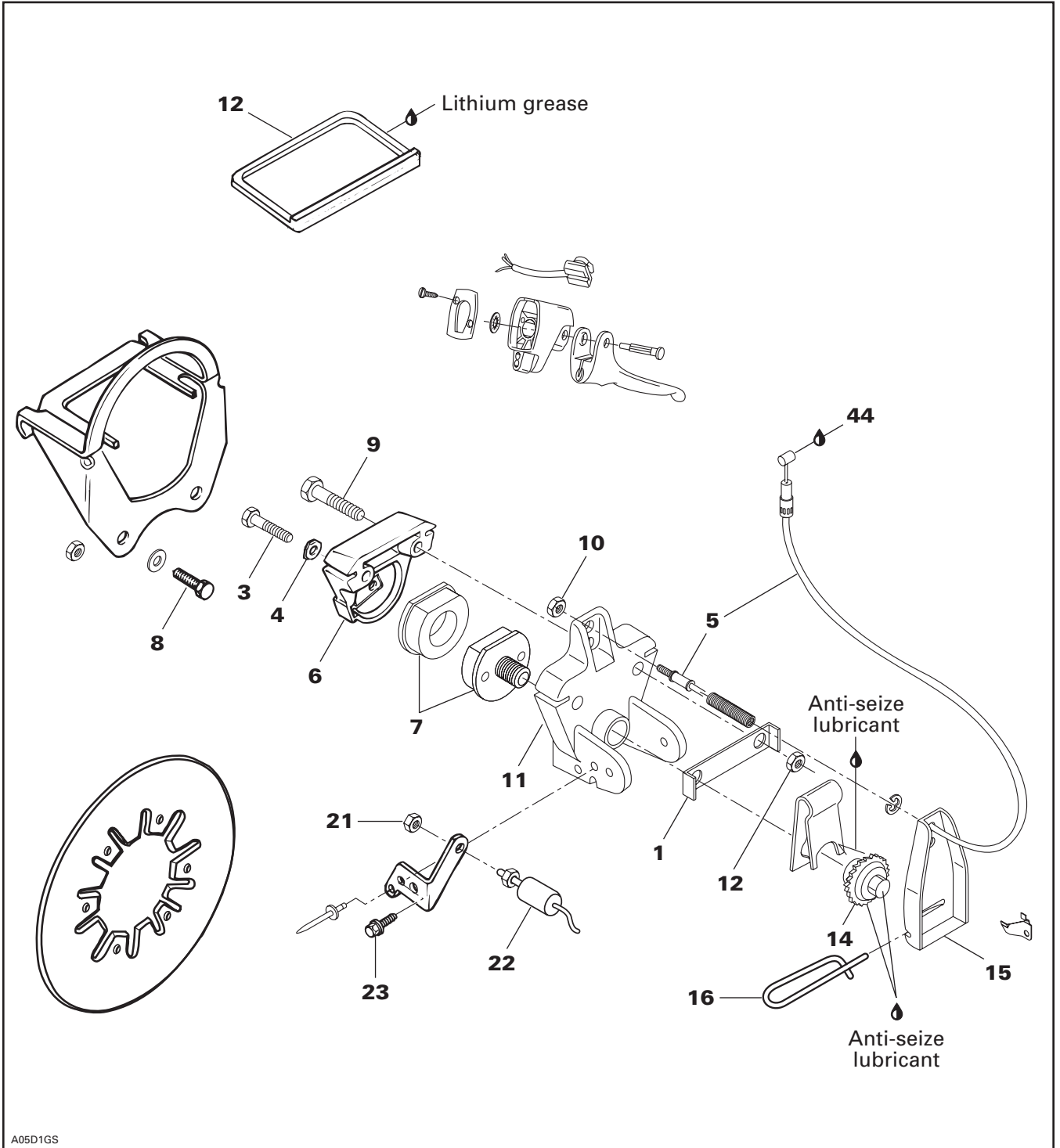

A05D1GS

Section 05 TRANSMISSION

Subsection 06 (BRAKE)

Skandic LT

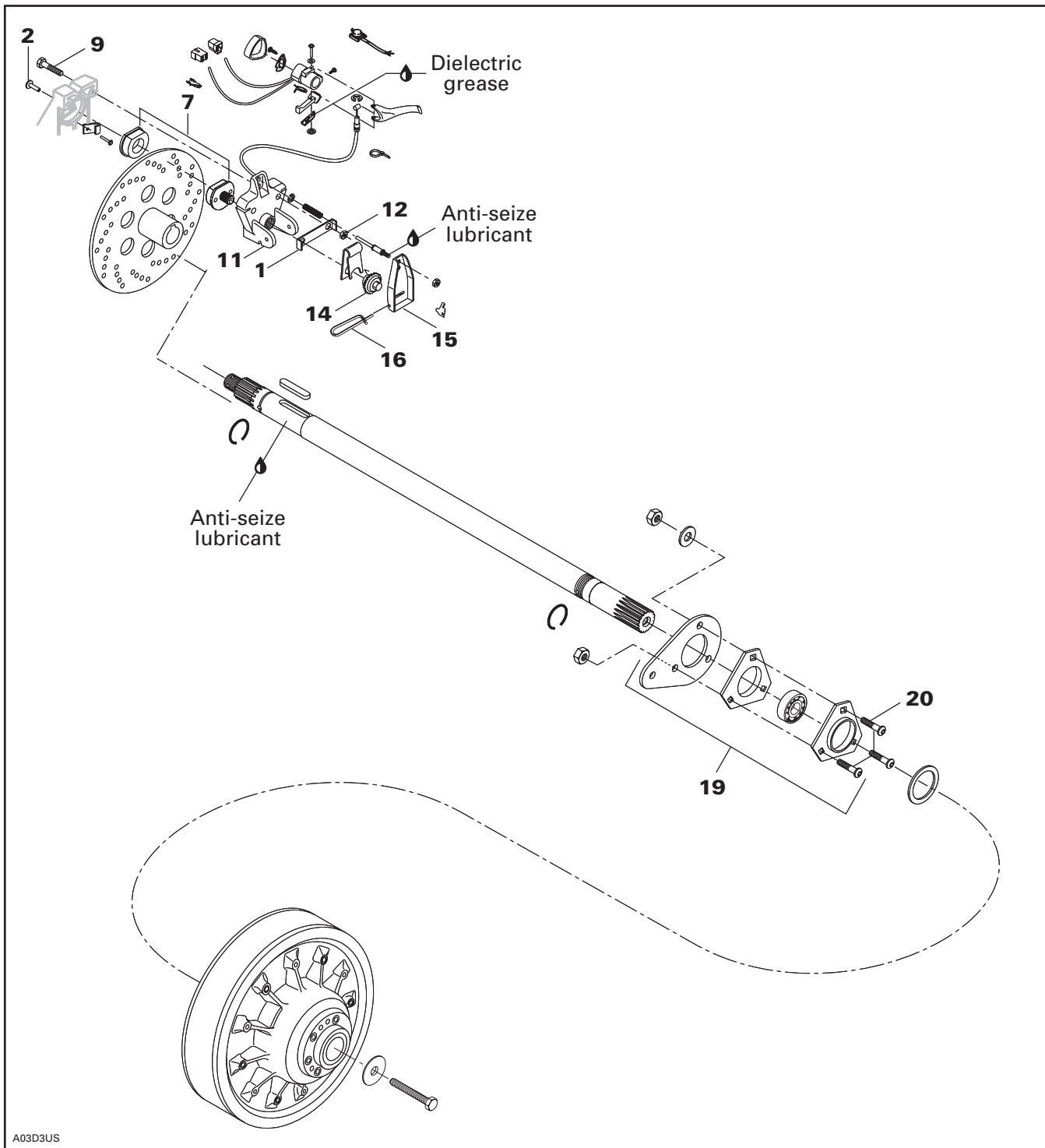

A03D3US

HYDRAULIC BRAKE

Skandic WT/SWT/WT LC

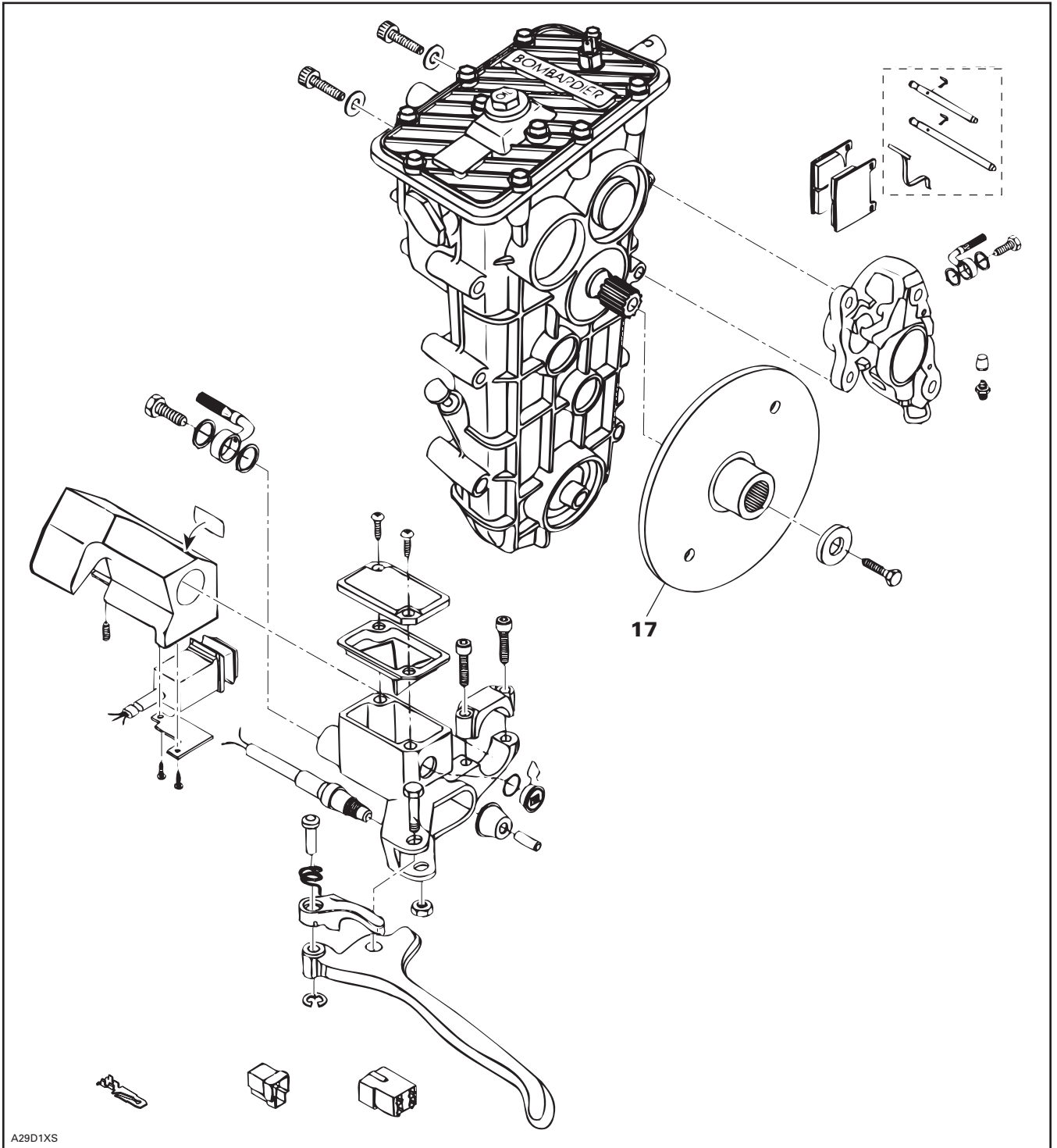

Section 05 TRANSMISSION

Subsection 06 (BRAKE)

REMOVAL

Brake Disc Removal

Tundra R

The split caliper type brake should be removed from chaincase as an assembly. Proceed as follows:

- Remove guard.
- Disconnect brake cable.
- Remove bolts **no. 8** securing brake support to chaincase.
- Slide brake caliper ass’y out of brake support.
- To remove brake disc, driven pulley has to be removed first. Refer to DRIVEN PULLEY.

Skandic WT/SWT/WT LC

- Remove caliper by unscrewing M10 Allen screws.
- Unbolt disc.

Skandic LT

- Remove caliper.
- Remove guard, belt and driven pulley.
- Remove air silencer.
- Unbolt bearing support **no. 19** from chassis.
- Open chaincase and remove upper sprocket.
- Pull countershaft assembly toward driven pulley side to gain access to clip **no. 25**.
- Remove clip **no. 25** on countershaft.

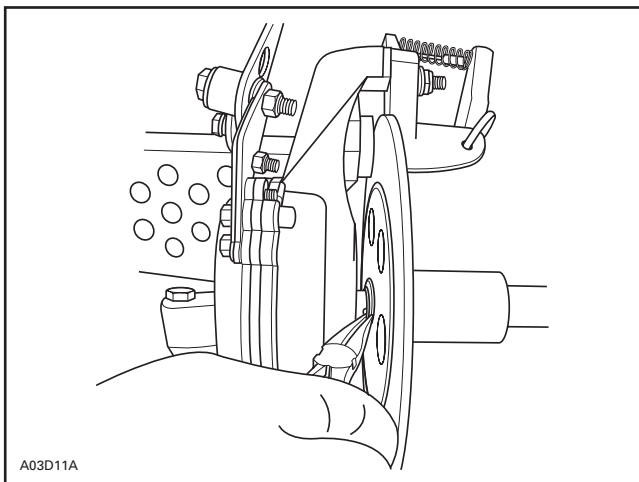

- Pull countershaft toward driven pulley side to free from chaincase and disc.
- Remove disc.

DISASSEMBLY

All Models with Mechanical Brake

Pull pin **no. 16** out of caliper and remove lever **no. 15**.

Fixed pad is riveted to chaincase on these models. Caliper must be split to remove moving pad. To remove fixed pad, drill out its rivet **no. 2** then pry disc in order to free fixed pad.

All Models with Hydraulic Brake

Only brake pads are available as spare parts. If caliper or master cylinder are damaged, replace each of them as an assembly.

CLEANING

Clean all metal components in a general purpose solvent. Thoroughly dry all components before assembling.

CAUTION: Do not clean brake pads in solvent. Soiled brake pads must be replaced by new ones.

INSPECTION

7, Brake Pad

Models with Mechanical Brake

Brake pads must be replaced when **fixed** pad projects only 1 mm (1/32 in) from caliper.

CAUTION: Brake pads must always be replaced in pairs.

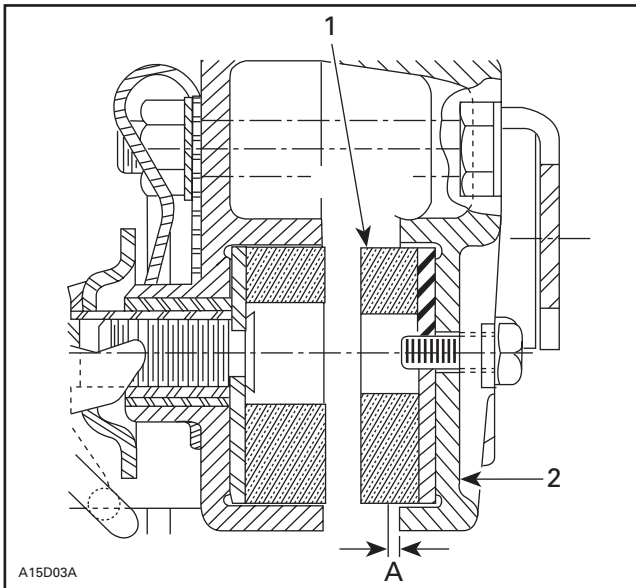

TYPICAL

- 1. Fixed pad
- 2. Inner caliper
- A. 1 mm (1/32 in) minimum

Models with Hydraulic Brake

Brake pads must be replaced when lining is 1 mm (1/32 in) thick.

CAUTION: Brake pads must always be replaced in pairs.

Brake Disc

All Models

Check for scoring, cracking or heat discoloration, replace as required.

CAUTION: Brake disc should never be machined.

ASSEMBLY

14, Ratchet Wheel

Apply synthetic grease (P/N 413 711 500) on threads and spring seat prior to installing. Fully tighten then back off one turn.

16, Pin

Install so that it can only be removed upward. Lock it in the caliper casting notch.

INSTALLATION

To install brake, reverse removal procedure paying attention to the following.

⚠ WARNING

Avoid getting oil on brake pads. Do not lubricate or apply antirust or antifreeze solution in brake cable.

17, Brake Disc

Skandic LT

The brake disc must be floating on countershaft for efficient operation of brake.

Apply anti-seize lubricant (P/N 413 701 000) on shaft and check that disc slides freely.

The disc hub exceeds the disc more from one side than from the other. Install disc with the longer exceeding portion toward driven pulley.

Push O-rings inside disc hub.

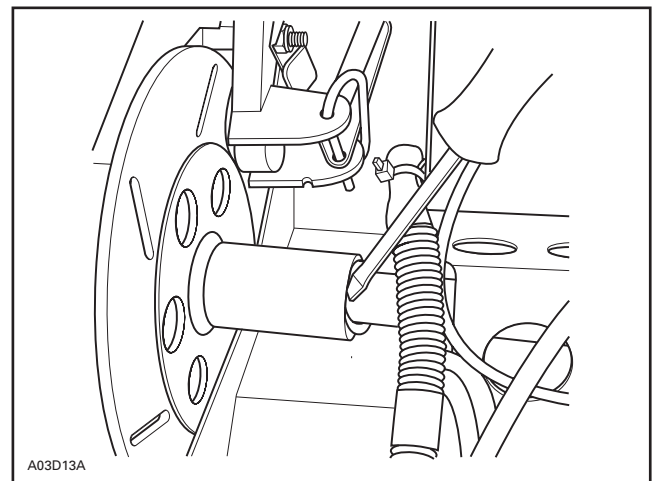

7, Brake Pad

Models with Hydraulic Brake

After brake pads installation, brake disc must be centered in caliper. Apply brake then check for proper brake disc positioning.

Push on appropriate caliper piston in order to move pad inward allowing proper brake disc positioning.

Section 05 TRANSMISSION

Subsection 06 (BRAKE)

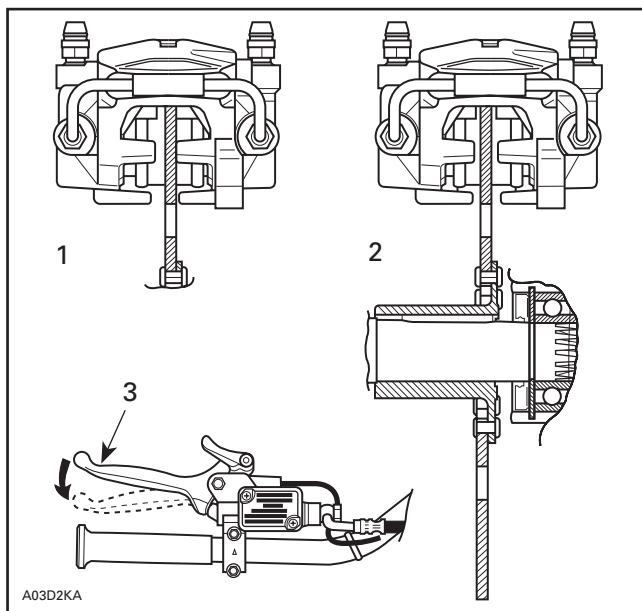

1. Brake disc not centered
2. Brake disc centered
3. Apply brake before checking

Apply brake then recheck.

1,11,12, Locking Tab, Outer Caliper and Nut

Skandic LT

Install caliper retaining bolts.

Assemble outer caliper. Install locking tab then nuts. Torque nuts to 24 N•m (18 lbf•ft). Bend locking tab over a flat of each nut.

5,12, Brake Cable and Nut

Insert brake cable into upper hole in brake lever and caliper. Install nut and tighten until a few threads exceed.

WARNING

At least 3 threads must exceed the elastic stop nut.

ADJUSTMENT

Brake

Models with Mechanical Brake

Fully depress brake handle several times to obtain 13 mm (1/2 in) between brake handle and handle-bar grip when brake is fully applied.

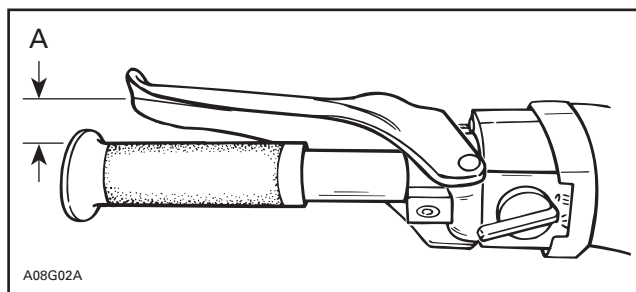

A. 13 mm (1/2 in)

Should this adjustment be unattainable, retighten nut no. 12 as needed.

Models with Hydraulic Brake

Change brake fluid once a year.

Bleed brake system as follows:

Keep sufficient DOT 4 brake fluid in reservoir at all times.

CAUTION: Use only DOT 4 brake fluid.

Install a hose on left side bleeder. Route this hose to a container.

Pump a few times brake lever and while holding brake lever depressed, open bleeder and check for air to escape.

Repeat with the same bleeder until no air appears in hose.

Proceed the same way with the right side bleeder.

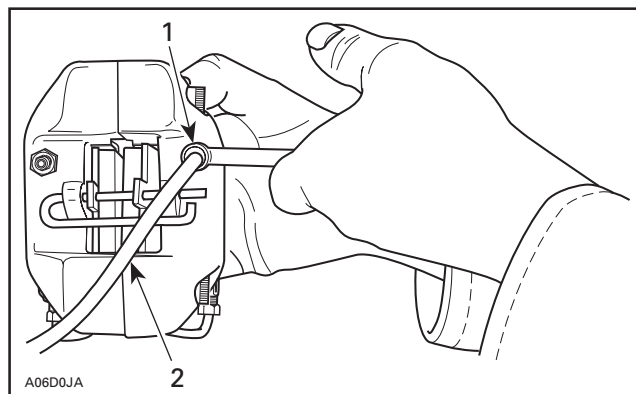

TYPICAL

1. Open bleeder
2. Clear hose to catch used brake fluid

Brake Light

Tundra R

Brake light should light up before brake pads touch brake disc. To adjust, unlock nut **no. 21** and turn brake switch **no. 22** accordingly. Lock in position by tightening nut **no. 21**.

Skandic LT

Brake light should light up before brake pads touch brake disc. To adjust, unscrew nut **no. 12** until brake light goes on.

WARNING

At least one full thread must exceed the elastic stop nut.

Check brake adjustment as described above.

NOTE: If brake light adjustment is unattainable while respecting brake adjustment, ratchet wheel may be too far out. If so, tighten ratchet wheel.

Models with Hydraulic Brake

There is no adjustment on these models. Check that switch is securely installed.

CHAINCASE

Tundra R

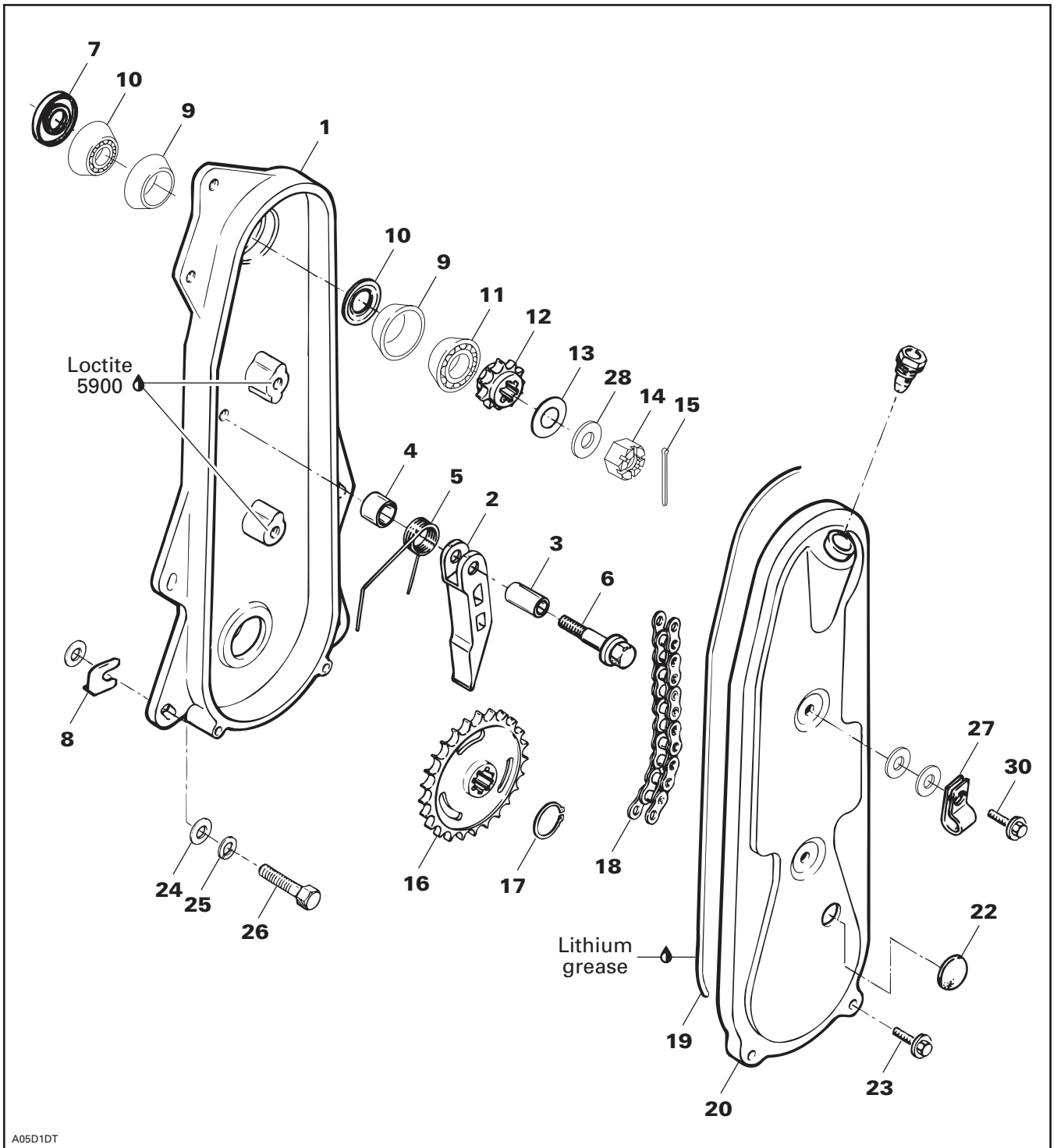

Section 05 TRANSMISSION

Subsection 07 (CHAINCASE)

REMOVAL

Chaincase and driven pulley can be removed from the vehicle as an assembly.

Remove guard and drive belt.

Unlock and raise driven pulley support.

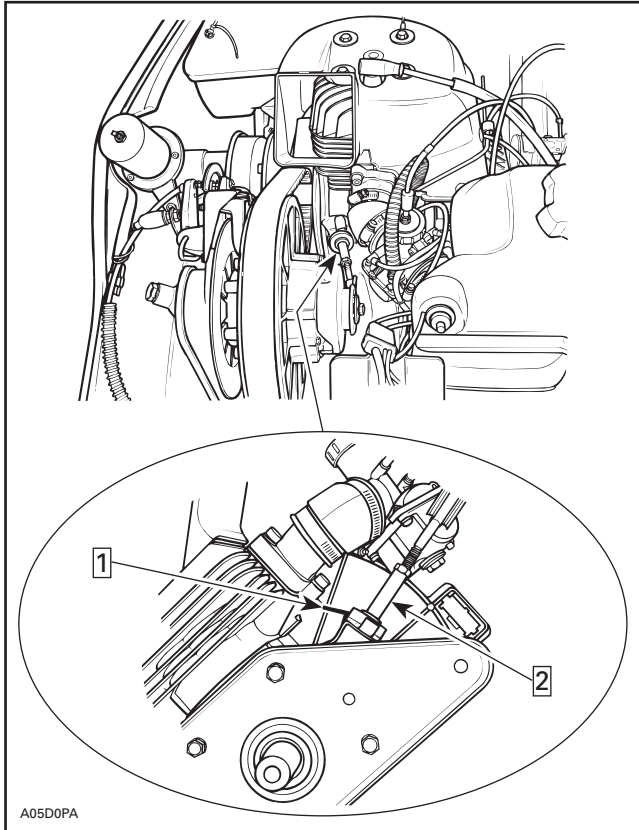

Step **1**: Push and hold

Step **2**: Raise support

Release track tension. Install drive axle holder (P/N 529 007 200).

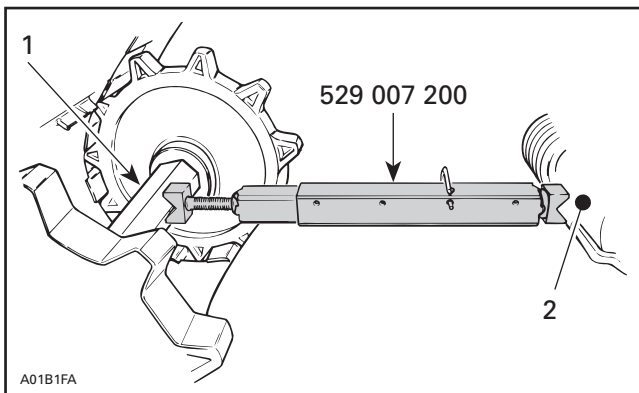

1. Drive axle

2. Suspension cross shaft

Remove chaincase cover **no. 20** and drain oil.

Remove right side drive axle bearing cover.

Remove circlip **no. 17**.

Move drive axle and track together to the right side as far as possible.

Unscrew the nut **no. 14** on the upper sprocket **no. 12**. Remove chain tensioner assembly **nos. 2 to 6**, then simultaneously remove chain **no. 18** and both sprockets.

Remove the 4 cap screws **no. 26** securing chaincase to frame. Save alignment shims **no. 8** for installation.

Chaincase and Driven Pulley Assembly

Using 2 large prybars inserted between chaincase and frame, pry complete assembly from vehicle.

DISASSEMBLY

Disassemble driven pulley from chaincase. Refer to DRIVEN PULLEY.

INSPECTION

Visually inspect the chain for cracked, damaged or missing link rollers. Check for defective bearings, sprockets and worn chain tensioner components.

⚠ WARNING

If chain deflection is greater than 38 mm (1.5 in) (without chain tensioner), replace chain and check condition of sprockets.

ASSEMBLY

Position oil deflector ring **no. 10** then sit bearing in chaincase aperture. Install spacer then the other bearing.

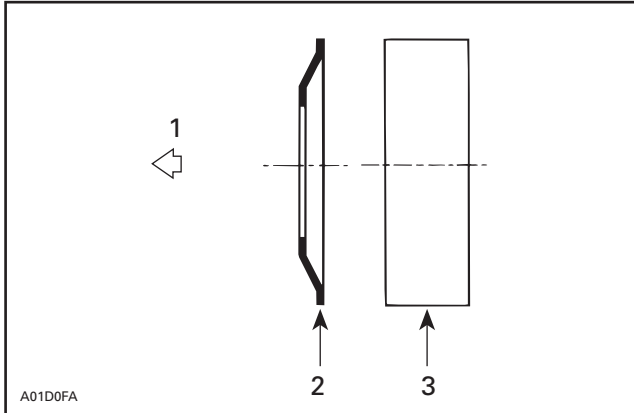

1. Toward chaincase
2. Oil deflector
3. Bearing

1, Oil Seal

Using an appropriate pusher, press new oil seal **no. 7** into chaincase hub. Oil seal must sit flush with case hub edge.

INSTALLATION

Reverse removal procedure. Pay particular attention to the following:

Torque castellated nut **no. 14** to 14 N•m (124 lbf•in), loosen then retorque to 0.5 - 2.5 N•m (5 - 22 lbf•in).

Apply Loctite 5900 (P/N 293 800 066) around both threaded holes of cover screws.

Grease new gasket **no. 19** with petroleum jelly, or other suitable product, and install it making sure it does not shift from its correct position. Tighten bolts evenly.

NOTE: Bottom pan has an emboss below chaincase housing to ease installation.

Chaincase Oil

Remove filler cap and pour 250 mL (8.5 fl. oz) of mineral chaincase oil (P/N 413 801 900) into chaincase.

NOTE: Chaincase oil capacity is 250 mL (8.5 fl. oz).

Check the oil level by removing the chaincase oil level plug.

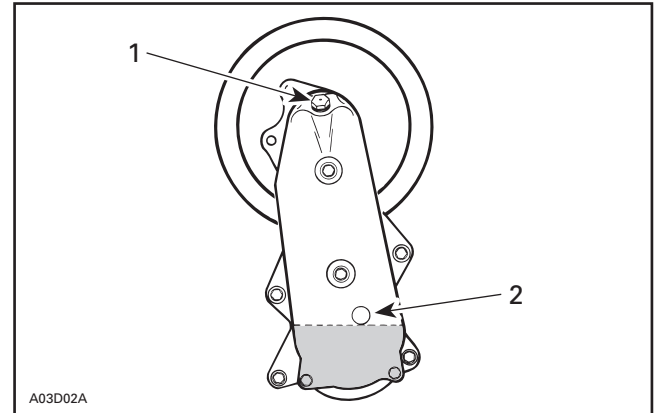

1. Filler cap
2. Oil level plug

The oil should be leveled with the bottom of the oil level orifice.

Reinstall battery and connect cables on electric starting models.

CAUTION: Always connect positive RED cable first to prevent sparks.

ADJUSTMENT

Pulley Alignment

Refer to PULLEY DISTANCE AND ALIGNMENT .

Track Tension and Alignment

Refer to TRACK.

Section 05 TRANSMISSION

Subsection 07 (CHAINCASE)

Skandic LT

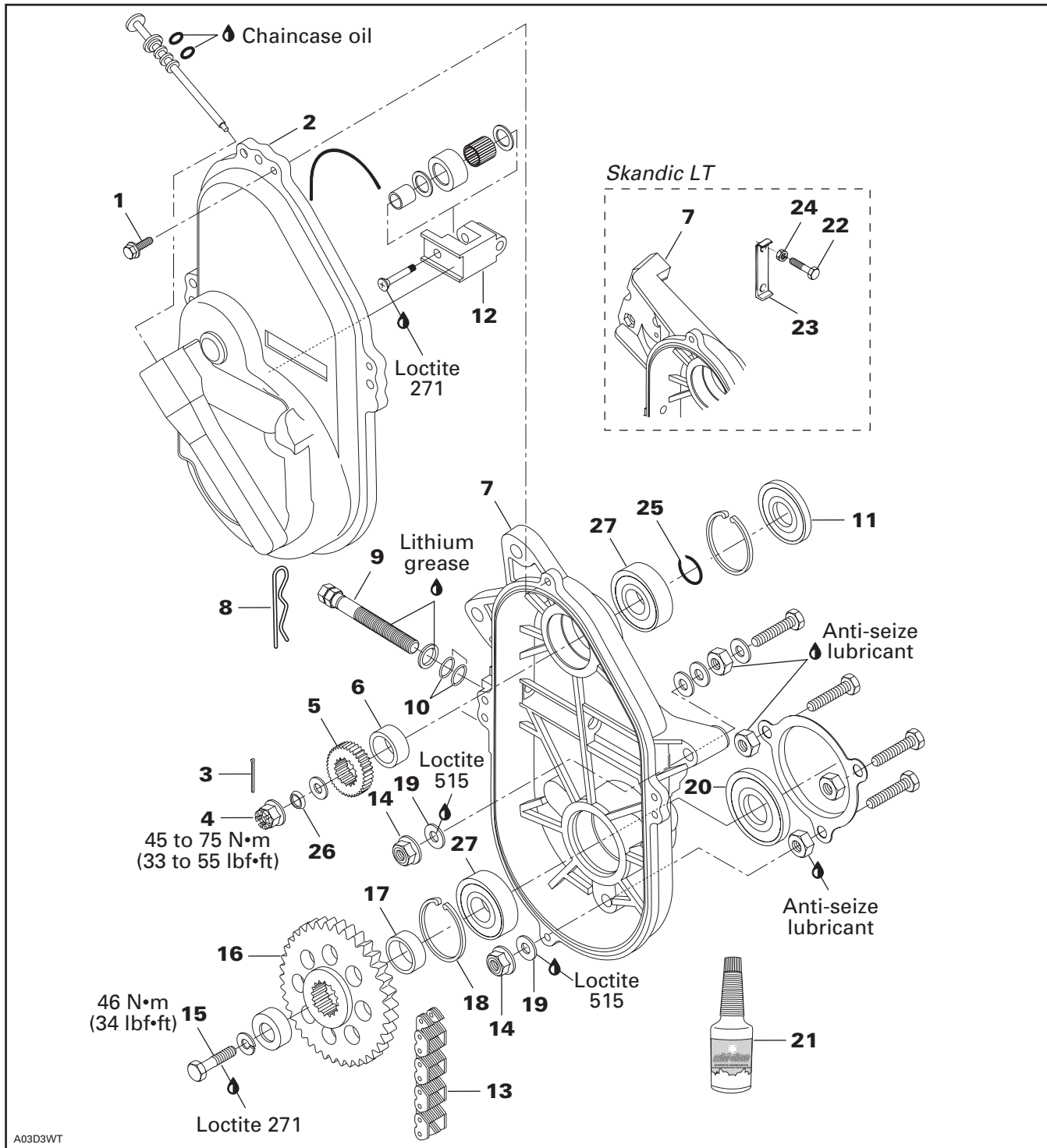

REMOVAL

To remove chaincase proceed as follows.

Remove tuned pipe and muffler.

⚠ WARNING

Never remove exhaust components when engine is hot.

Remove hair pin **no. 8**. Release drive chain tension by unscrewing tensioner adjustment screw.

Drain oil by removing chaincase cover **no. 2**.

Apply brakes.

Remove cotter pin **no. 3**, nut **no. 4**, washer **no. 26** retaining upper sprocket **no. 5** and screw **no. 15** retaining lower sprocket **no. 16**. Pull sprockets and drive chain simultaneously. Remove shims **nos. 6** and **17**.

NOTE: Should countershaft removal be required, refer to BRAKE then look for **Brake Disc**.

Remove 5 nuts **no. 14**. Three nuts are behind the lower sprocket.

Unfold locking tab **no. 23**, then remove caliper retaining screws **no. 22**.

Release track tension, use drive axle holder (P/N 529 007 200).

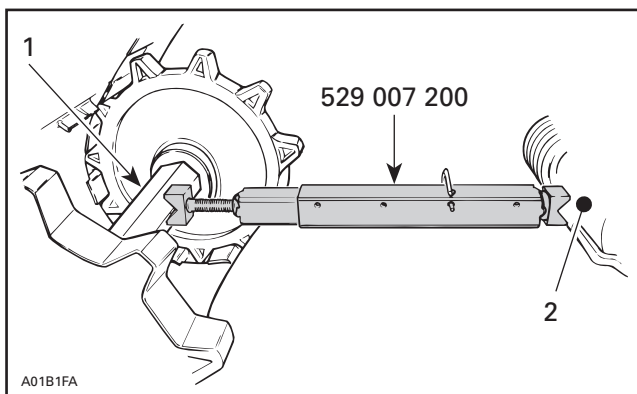

TYPICAL

1. Drive axle
2. Suspension cross shaft

Pry out drive axle oil seal **no. 20** from chaincase.

Pull chaincase from drive axle and countershaft.

Using 2 prybars inserted between chaincase **no. 7** and frame, pry complete assembly from vehicle.

INSPECTION

Visually inspect the chain for cracked, damaged or missing links. Check for worn or defective bearings, sprockets and chain tensioner components.

⚠ WARNING

If chain deflection is greater than 38 mm (1.5 in) (without chain tensioner), replace chain and check condition of sprockets.

GEAR RATIO MODIFICATION

For particular applications, the number of teeth of the sprockets can be increased or decreased on lower and upper sprockets.

Refer to TECHNICAL DATA for gear ratios.

CAUTION: Gear ratio modifications should only be performed by experienced mechanics since they can greatly affect vehicle performance.

NOTE: For high altitude regions, a Service Bulletin will give information about calibration according to altitude.

INSTALLATION

Reverse removal procedure and pay attention to the following. Replace oil seals, gaskets and O-rings. Sealed side of bearing **no. 27** must face chaincase cover.

11, Oil Seal

Clean chaincase bore with cleaning solvent then apply Loctite 609 to oil seal mounting surface (outside).

Using pusher (P/N 529 035 584), press the oil seal into chaincase hub. Oil seal must fit flush with the chaincase edge.

NOTE: Should installation procedure for countershaft be required, refer to BRAKE then look for **Brake Disc and Countershaft Bearing Adjustment**.

5,16, Sprockets

Position the sprockets with the writing facing the chaincase cover.

Section 05 TRANSMISSION

Subsection 07 (CHAINCASE)

26, Conical Spring Washer

Install washer with its concave side towards sprocket.

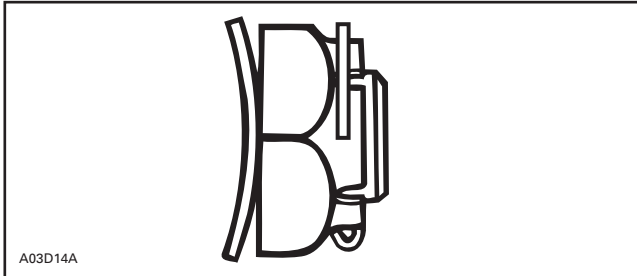

4, Upper Sprocket Castellated Nut

Torque to 45 to 75 N•m (33 to 55 lbf•ft).

Install new cotter pin in the position shown.

CAUTION: When removing a cotter pin always replace with a new one.

CAUTION: Cotter pin will rub on chaincase cover if installed otherwise.

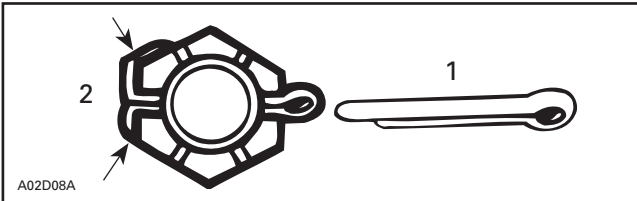

1. New
2. Fold cotter pin over castellated nut flats only

18, Circlip

CAUTION: It is of the utmost importance to install the circlip otherwise damage to the chaincase components may occur.

DRIVE CHAIN ADJUSTMENT

NOTE: Brake disc key must be in good condition before checking chain free play.

10, O-Ring

Replace both O-rings **no. 10** on tensioner adjustment screw. Fully tighten tensioner adjustment screw **by hand**, then back off only far enough for hair pin to engage in locking hole.

This initial adjustment should provide 3 - 5 mm (1/8 - 13/64 in) free-play when measured at the outer circumference of the brake disc.

CAUTION: Free-play must not exceed 5 mm (13/64 in), readjust if necessary.

⚠ WARNING

If the specified free-play is not reached with the tensioner screw fully tightened, replace chain and check the condition of sprockets.

21, Chaincase Oil

Pour 250 mL (8.5 fl. oz) of synthetic chaincase oil (P/N 413 803 300) into chaincase.

Check oil level with the dipstick then add if required. Remove metal particles from magnet.

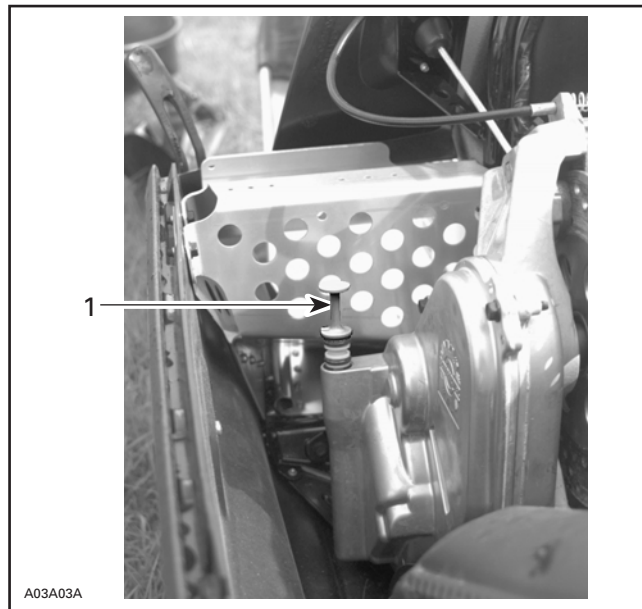

TYPICAL

1. Dipstick

NOTE: Chaincase must be in its proper position when checking oil level.

ADJUSTMENT

Pulley Alignment

Refer to PULLEY DISTANCE AND ALIGNMENT.

Track Tension and Alignment

Refer to TRACK.

GEARBOX

3-SPEED GEARBOX

Skandic WT/SWT/WT LC

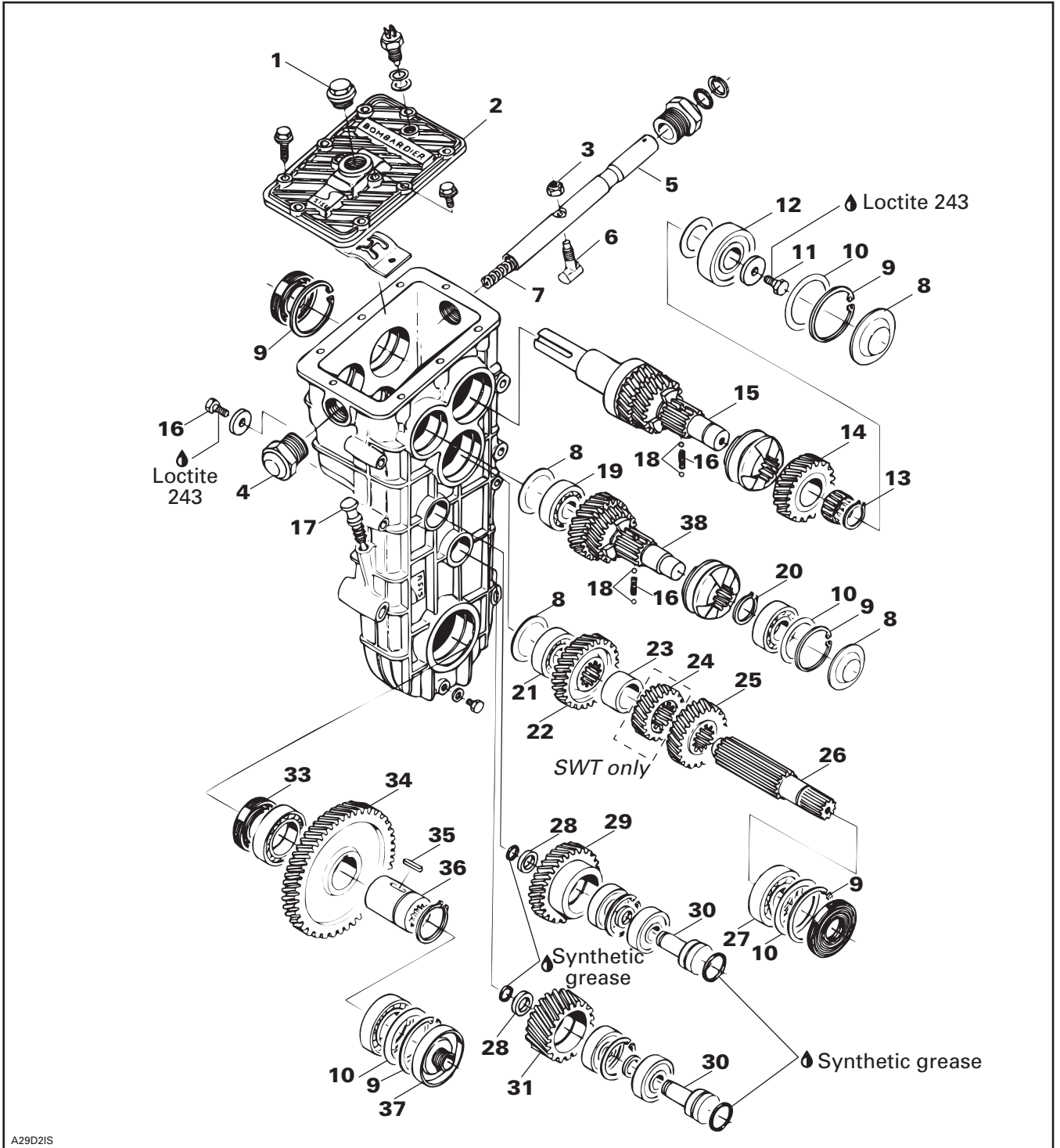

A29D2IS

Section 05 TRANSMISSION

Subsection 08 (GEARBOX)

REMOVAL

Drain gearbox oil.

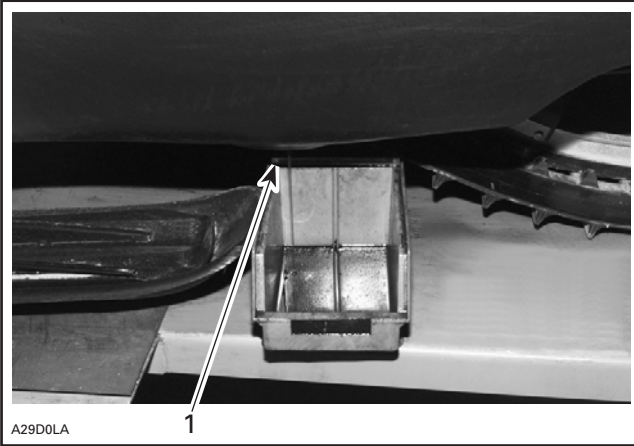

1. Bottom pan drain hole nearby gearbox drain plug

Remove belt guard, drive belt. Remove air silencer and carburetor(s); then remove driven pulley.

Remove brake caliper, brake disc. Unfasten shifting rod and unplug reverse switch.

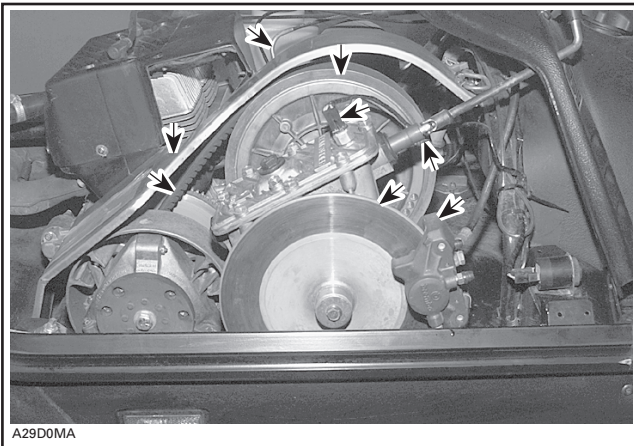

A29D0MA

Remove rear suspension.

Remove angle drive and square pin from bottom of gearbox.

Remove muffler. Unbolt RH end bearing then pull drive axle toward right side.

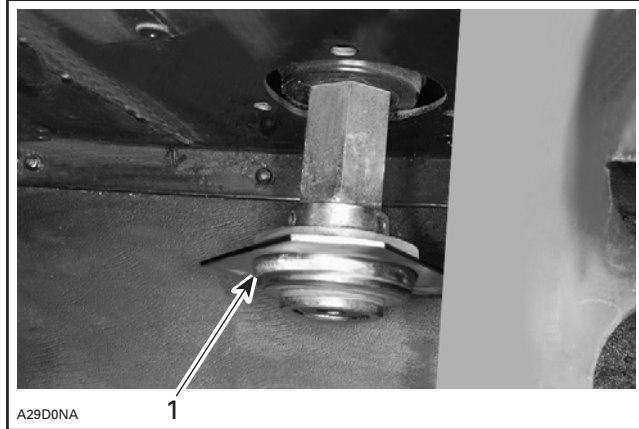

1. RH end bearing

Unbolt gearbox from chassis.

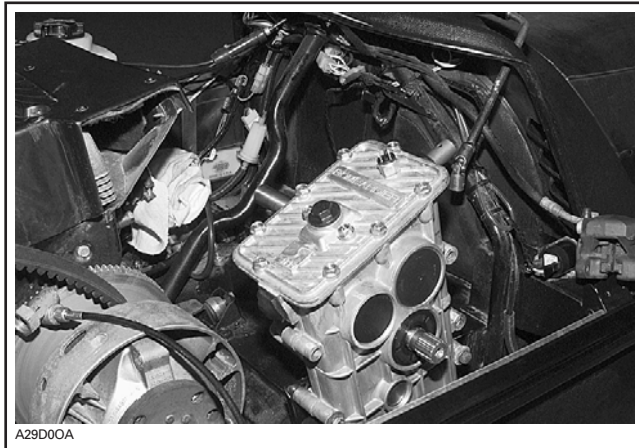

A29D0OA

DISASSEMBLY

For the following procedure, right hand side refers to driven pulley side and left hand side to brake disc side.

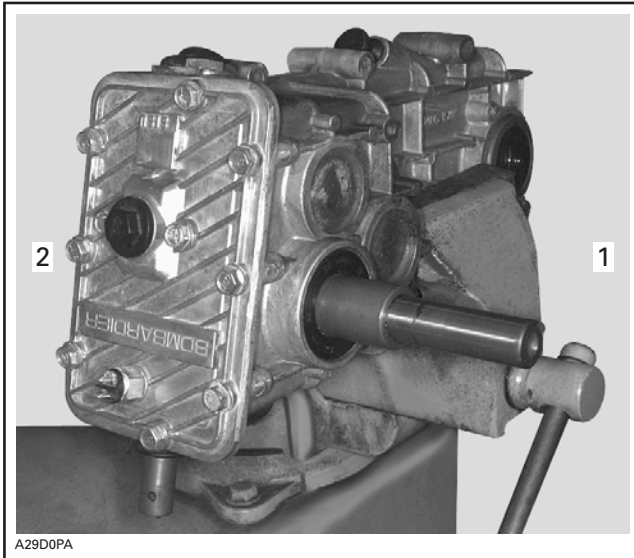

1. RH side driven pulley side
2. LH side brake disc side

Remove dipstick no. 17. Unfasten cover no. 2 from gearbox housing.

Remove nut no. 3 retaining pin no. 6.

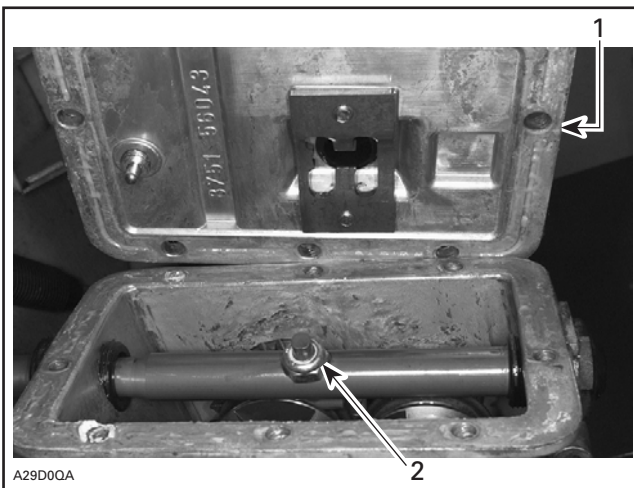

1. Cover
2. Nut

Unfasten sleeve nut no. 4, remove spring no. 7 then, partially pull shaft no. 5 and remove pin no. 6.

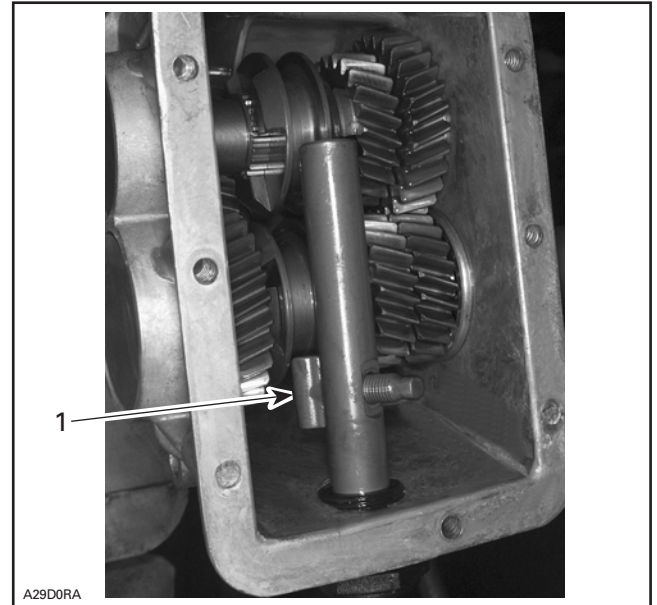

1. Pin

Completely remove shaft no. 5.

Drill a 10 mm (3/8 in) diameter hole through all plugs no. 8.



Remove all plugs no. 8 from gearbox.

Section 05 TRANSMISSION

Subsection 08 (GEARBOX)

Remove all circlips no. 9.



IMPORTANT: Note all shims quantity and location.
Remove brake shaft oil seal and then circlip.

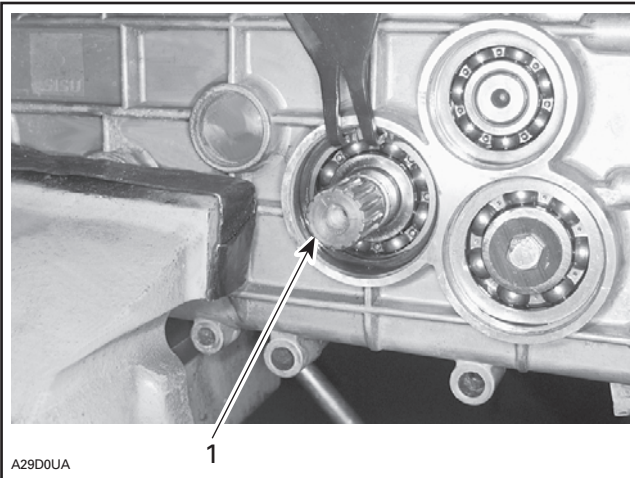

1. Brake shaft

Proceeding from right side, drive brake shaft out of gearbox housing.

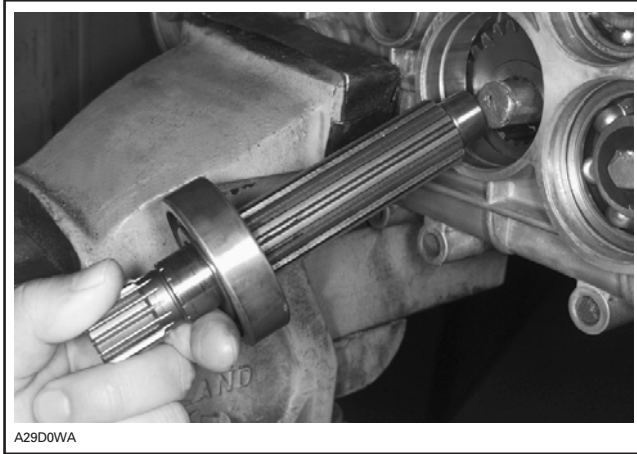
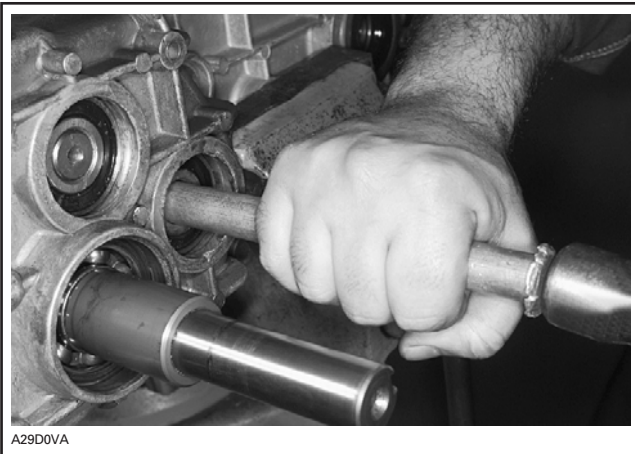

Remove sleeve no. 23.

NOTE: Brake shaft gears remain in gearbox housing.

Remove bearing no. 27 from brake shaft no. 26 using a press.



Drive reverse shaft no. 38 out until its LH side bearing is free.

Section 05 TRANSMISSION

Subsection 08 (GEARBOX)

Make sure gears mesh.

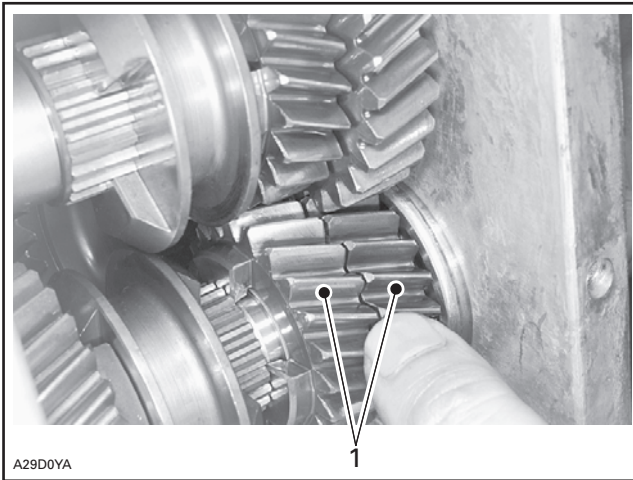

1. These gears must mesh as reverse shaft is driven out

Shift in reverse gear.

Turn reverse shaft so its sliding sleeve dog will not touch the RH gear of driven pulley shaft no. 15. This will allow the driven pulley shaft to be pushed out enough for bearing removal.

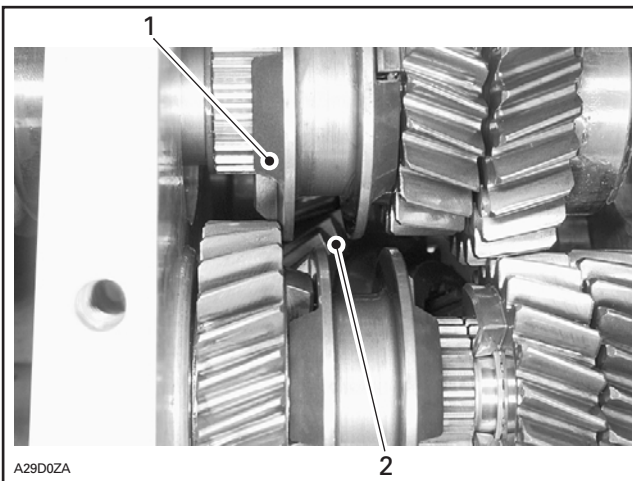

1. Sleeve dog not touching right gear
2. Brake shaft gears are still in gearbox

Use a puller to extract LH reverse shaft bearing.

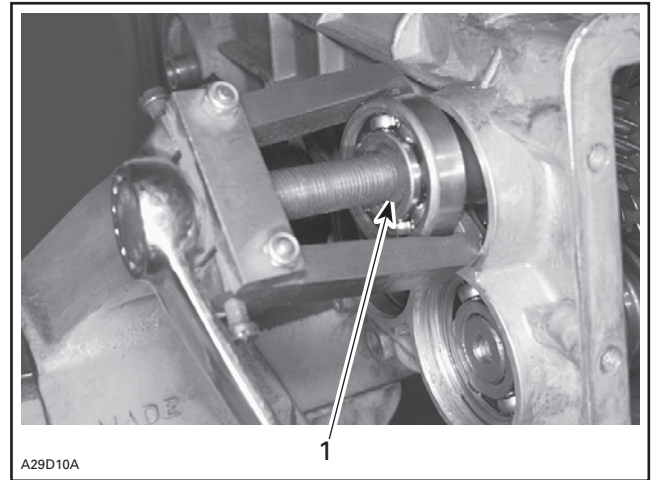

1. Extract reverse shaft LH side bearing

To remove sliding sleeve from reverse shaft, first remove circlip.

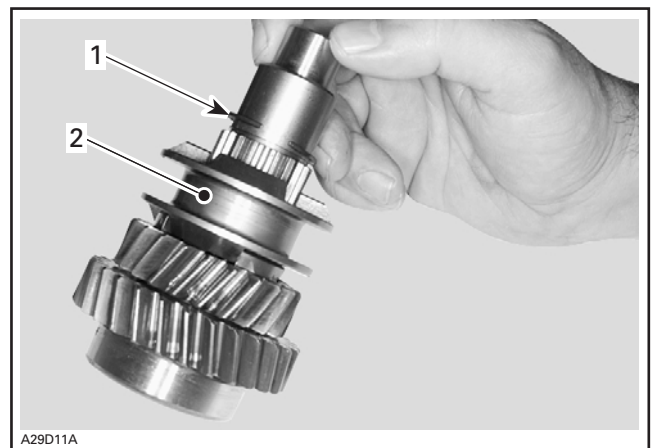

1. Circlip
2. Sliding sleeve

Section 05 TRANSMISSION

Subsection 08 (GEARBOX)

Use a puller to extract bearing no. 19.

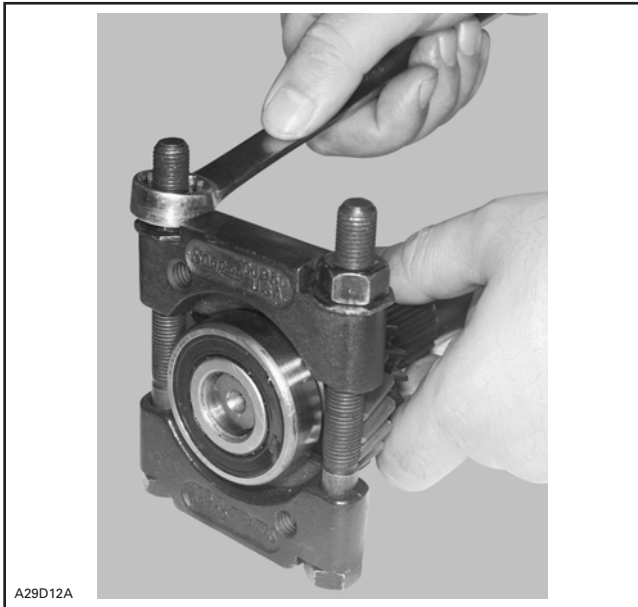

Use a puller to extract bearing no. 12.

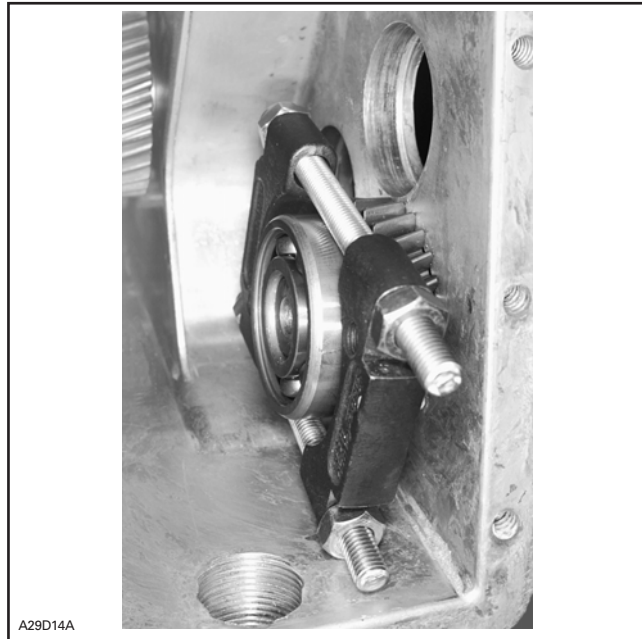

Remove brake shaft gears.

Unbolt driven pulley shaft screw no. 11 and remove washer.

Push driven pulley shaft no. 15 out of gearbox until its LH gear no. 14 is against gearbox inner wall.

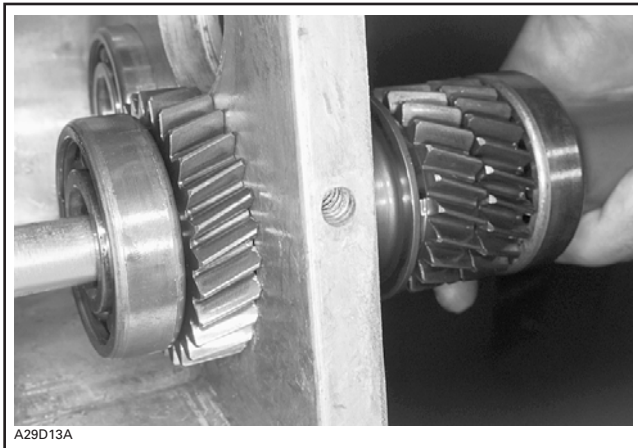

Remove circlip then, gear no. 14. Now driven pulley shaft can be pulled out from gearbox.

Remove sliding sleeve taking care not to lose balls no. 18 and spring no. 16.

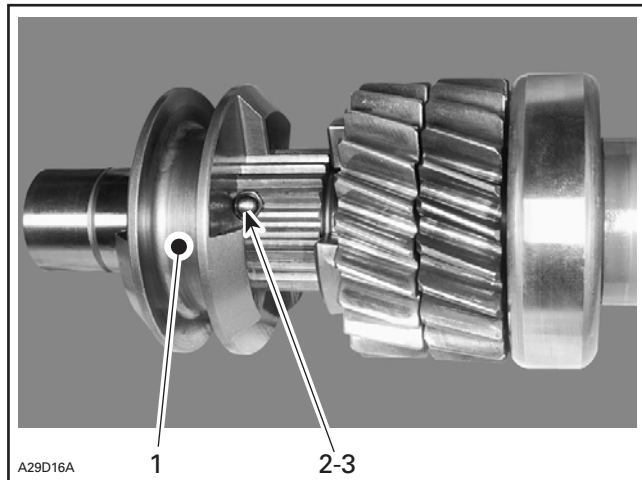

1. Sliding sleeve
2. Spring
3. Balls

Section 05 TRANSMISSION

Subsection 08 (GEARBOX)



DRIVEN PULLEY SHAFT COMPONENTS

Remove screws no. 16 from intermediate shafts no. 30.

Fasten a long M8 x 1.25 screw in axle end then drive it out, beginning with top one.

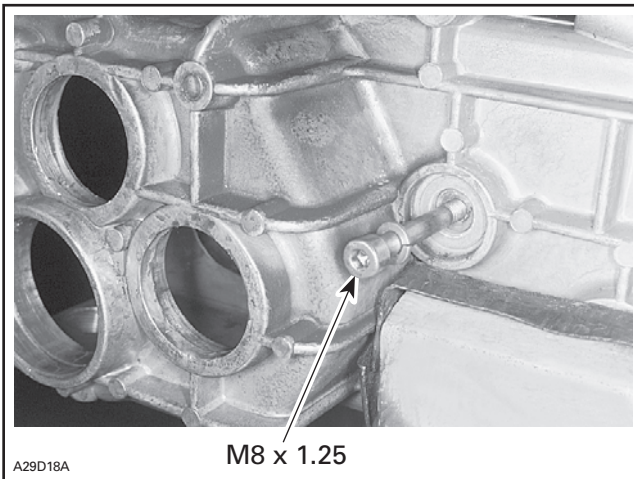

Remove intermediate gears and spacers.

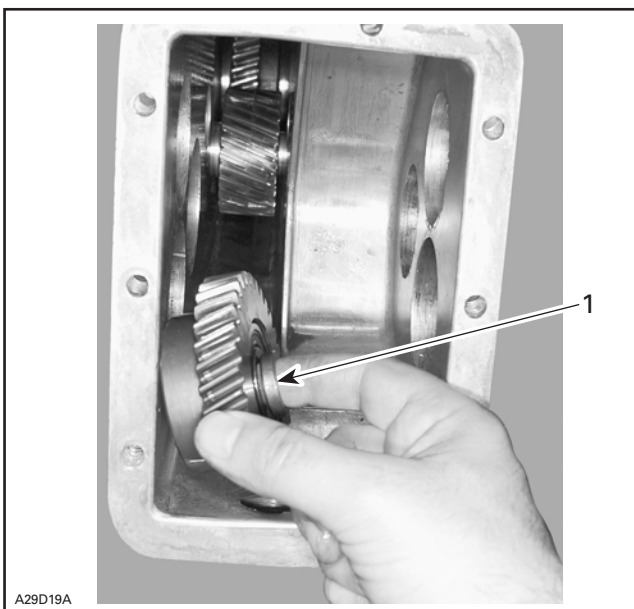

1. Spacer

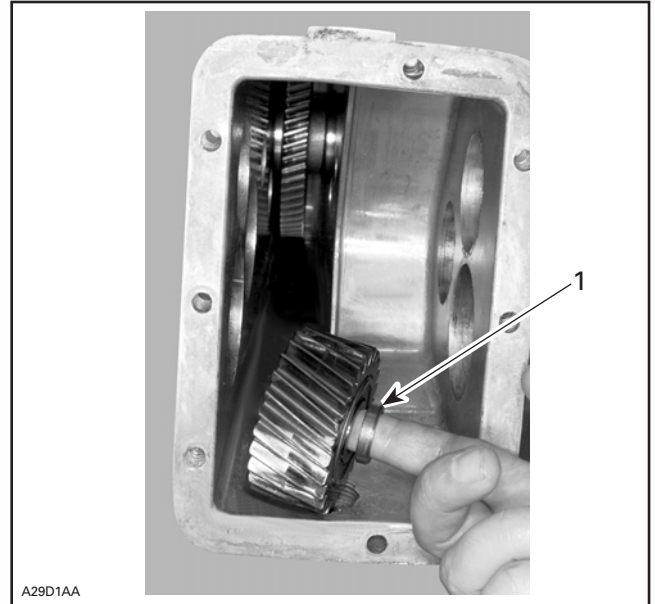

1. Spacer

Do not disassemble bearings of intermediate gears needlessly.

Pry out bottom seal no. 33 from gearbox housing. Remove circlip no. 9.

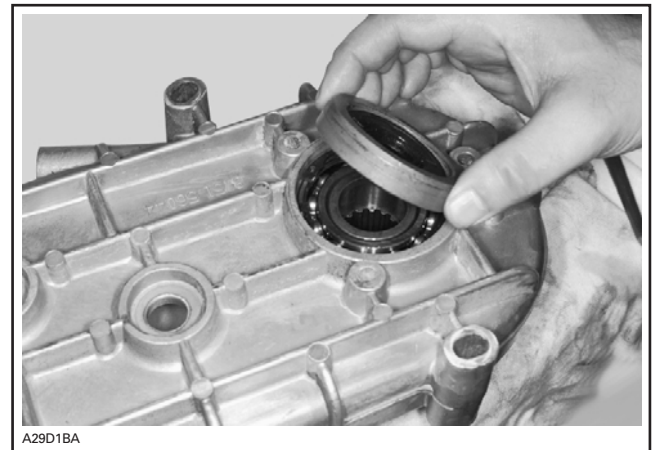

Section 05 TRANSMISSION

Subsection 08 (GEARBOX)

Drive out plug no. 37.

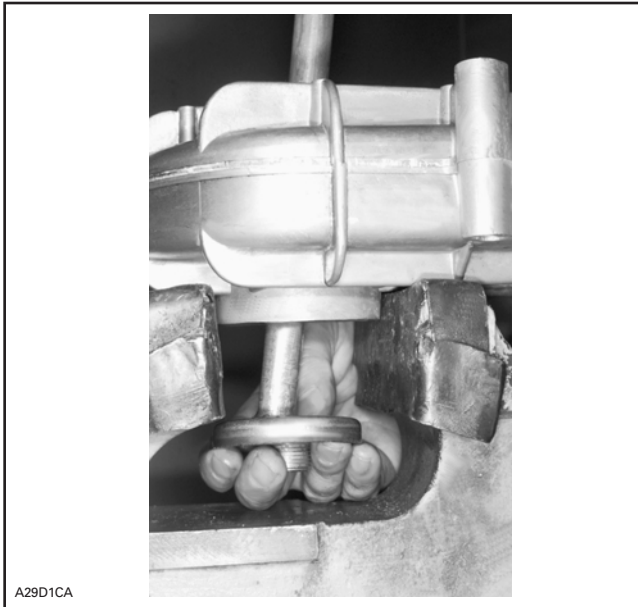

Remove circlip no. 9 from LH side.



Using a press, drive out lower shaft no. 36 from RH side.

CAUTION: Do not push against inner bearing race.

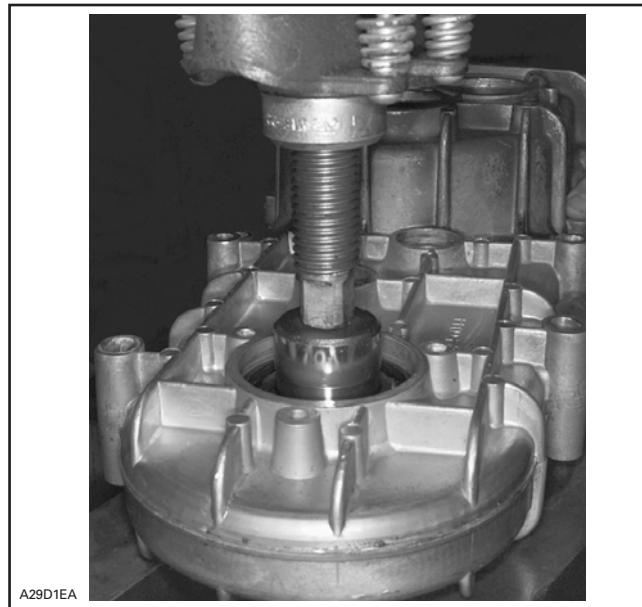

INSPECTION

Check bearing condition. There must be no discoloration, missing rollers or balls, broken cages, etc. Check sprocket teeth.

ASSEMBLY

Install lower gear no. 34 with its shoulder facing RH side.

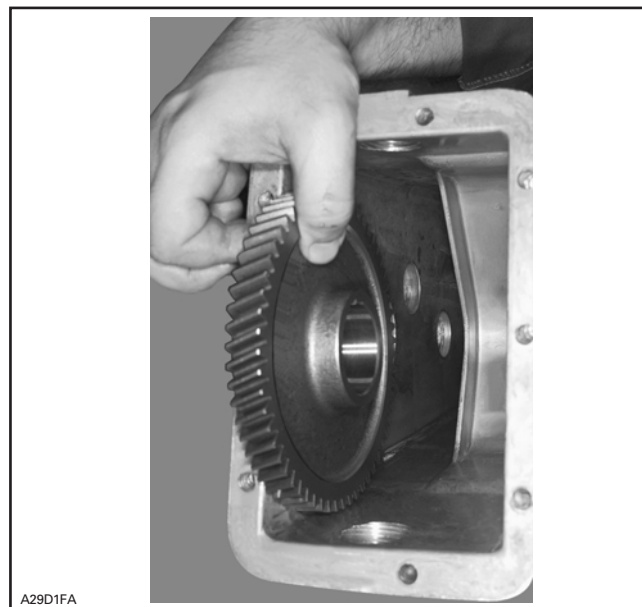

Section 05 TRANSMISSION

Subsection 08 (GEARBOX)

Install lower shaft **no. 36** with its hollow side (no splines) on RH side. Align key with lower gear **no. 34** keyway.



Apply synthetic grease (P/N 413 711 500) on intermediate shaft O-rings.

Install intermediate gears **no. 29** with their shoulder towards LH side. Position spacers **no. 28** as illustrated in removal procedure. Beveled side of spacers goes against gearbox wall.

Install RH side bearing of brake and reverse shafts.



Partially assemble brake shaft gears **nos. 24** and **25** with shoulder facing recess.

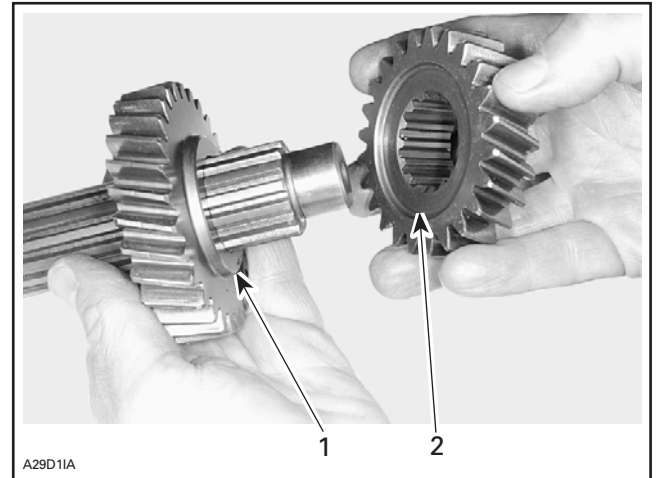

1. Shoulder
2. Recess

Install sleeve **no. 23** on brake shaft **no. 26** then, slide gears and sleeve until end of sleeve is flush with shaft end.

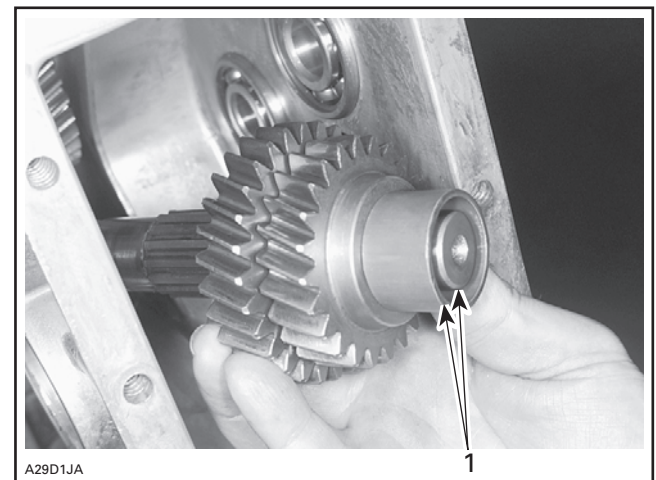

1. Flush

Install brake shaft **no. 26** into gearbox then, loosely install gear **no. 22** with its shoulder facing bearing **no. 21**. Do not push brake shaft into bearing **no. 21** at this time.

Section 05 TRANSMISSION

Subsection 08 (GEARBOX)

Install reverse shaft ass'y no. 38 into its RH side bearing no. 19.

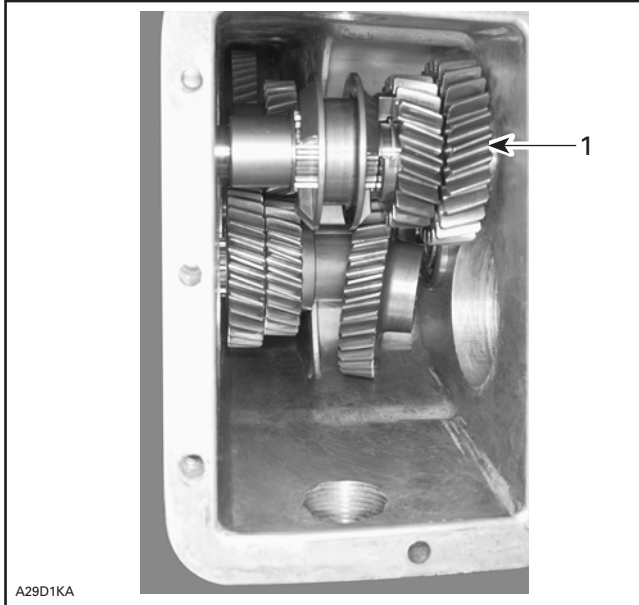

1. Reverse shaft installed in its RH bearing

Position gear no. 22 against RH side bearing no. 19 then, finalize brake shaft no. 26 insertion.

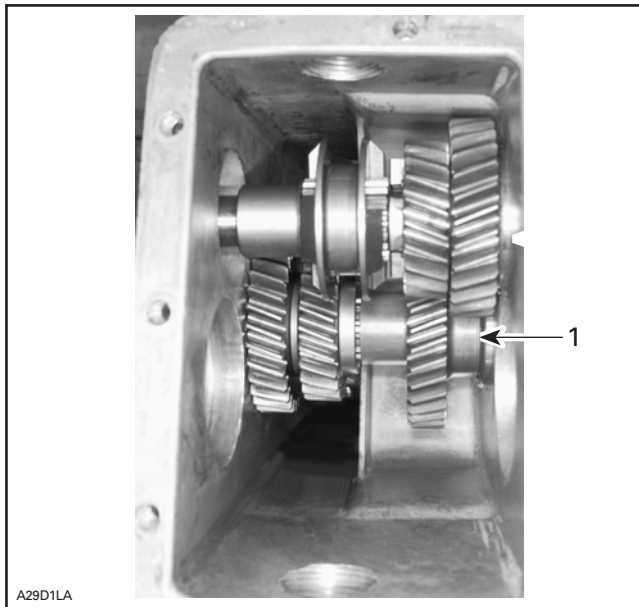

1. Finalizing brake shaft insertion

Install driven pulley shaft no. 15 with the sliding sleeve loosely inserted. Gear no. 14 must be at its place.

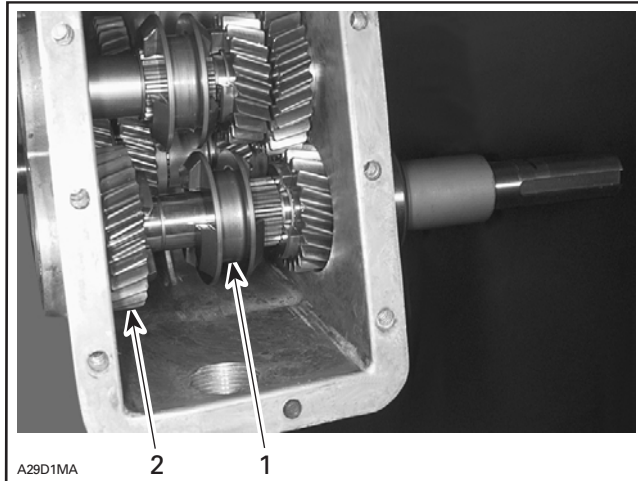

1. Sliding sleeve loosely inserted
2. Gear no. 14 in place

Install balls no. 18 and spring no. 16 into driven pulley shaft.

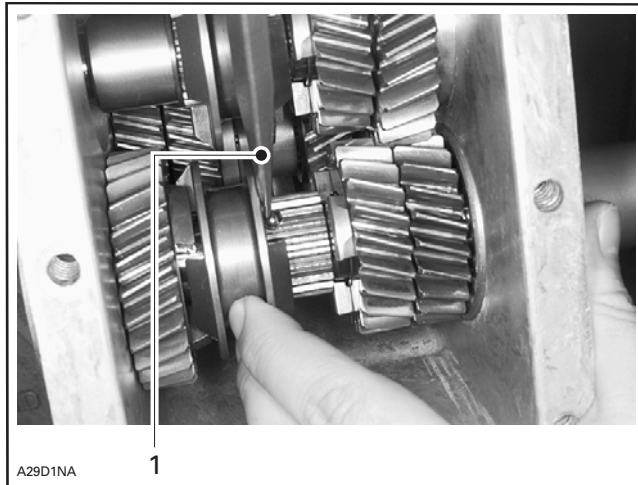

1. Push on ball with a screwdriver then move sliding sleeve to the right

Finalize driven pulley shaft insertion. Make sure that gears mesh during insertion. Install circlip no. 20.

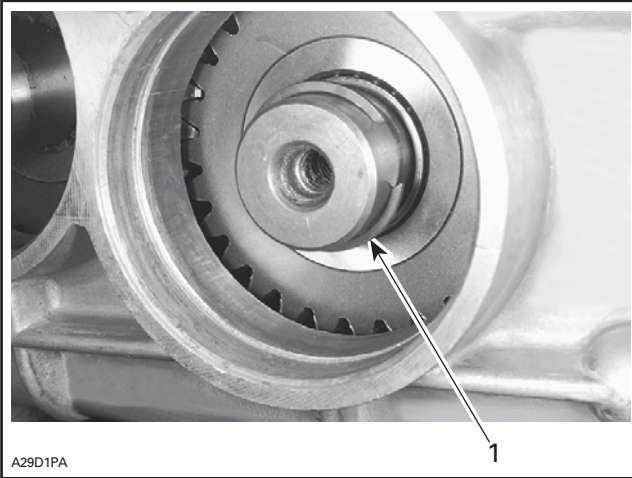

1. Circlip

Install LH side bearings nos. 12, 19 and 21, shims no. 8, circlip no. 9 then, plugs no. 8.

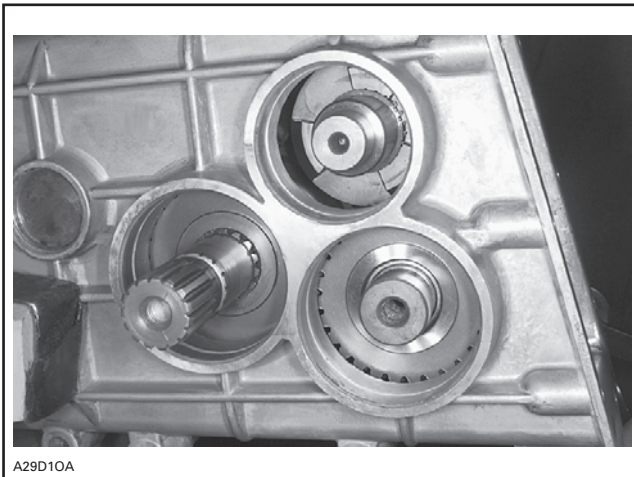

READY TO INSTALL BEARINGS, SHIMS, CIRCLIPS AND PLUGS

INSTALLATION

Reverse removal procedure. Check pulley alignment.

OIL LEVEL

To check, pull dipstick. Oil should reach level mark.

NOTE: After first outing, oil level will decrease as the upper oil cavity fills with oil. Recheck oil level and refill as required.

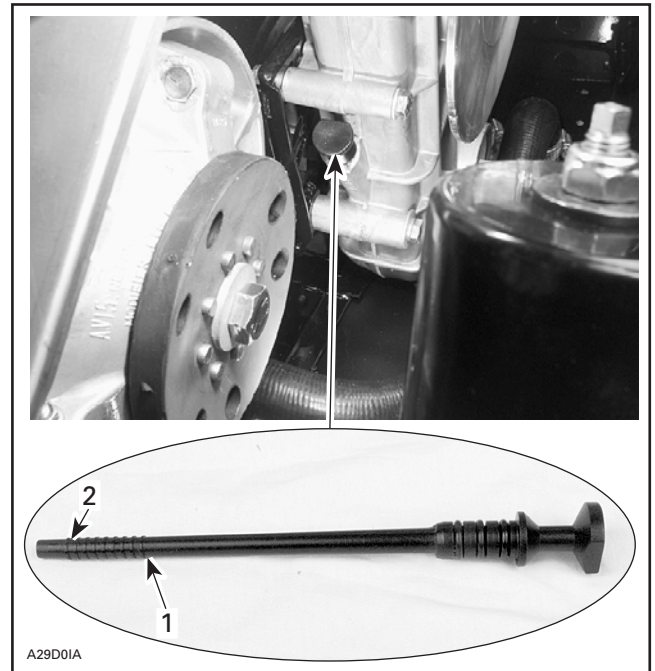

1. Full level mark
2. Lower level mark

To fill, remove filler plug from top of transmission. Refill as required using Bombardier synthetic chaincase oil (P/N 413 802 800 — 12 x 250 mL).

DRIVE CHAIN

GENERAL

Bombardier drive chains exist in 2 types, for proper use refer to TECHNICAL DATA.

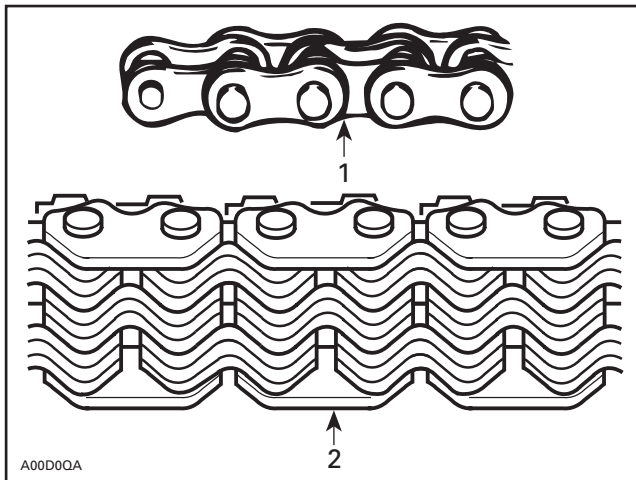

1. 1/2 in single
2. 3/8 in silent chain

SILENT CHAIN

There are 2 types of silent chain. One is 11-plates wide and the other is 13-plates wide (stronger). Do not interchange sprockets. Fit chain on sprockets to make sure using right ones according to width. Refer to TECHNICAL DATA.

NOTE: No work (separation, lengthening) can be done on the silent chain type.

CHAIN ATTACHMENT

When joining chain ends, the open end of the circlip must be on opposite side of chain rotation. The circlip should also be facing the outer side of chaincase.

WARNING

Always ensure that the connecting link circlip is in good condition and is properly secured.

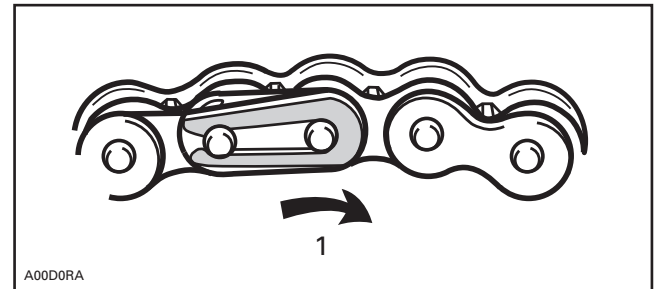

TYPICAL

1. Rotation

CHAIN SEPARATION

When separating an endless chain, always use a chain bearing pin extractor. Also, make sure to remove one complete link.

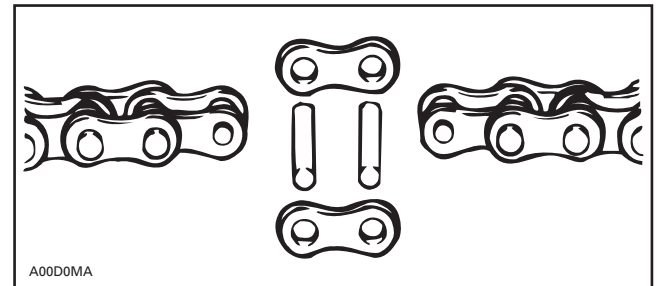

NOTE: Chain connecting link should only be used to lengthen or shorten a chain when changing the sprocket(s) for one(s) with a different number of teeth. A stretched chain must never be shortened because the chain pitch has changed (increased) and will not properly match the sprocket pitch, causing premature wear.

NOTE: Refer to TECHNICAL DATA, for chain length according to gear ratio of each specific vehicle.

Section 05 TRANSMISSION

Subsection 09 (DRIVE CHAIN)

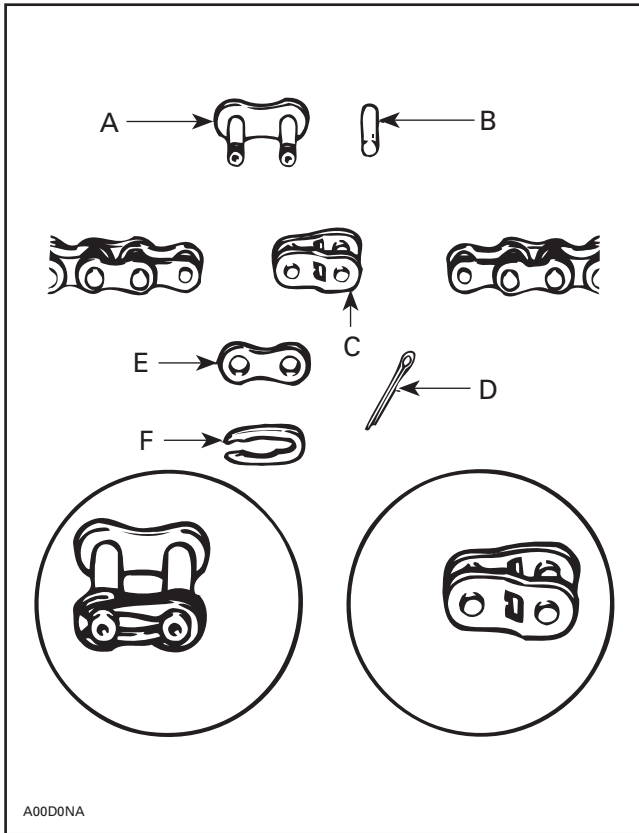

LENGTHENING 1/2 LINK

- A. Connecting link
- B. Link pin
- C. Cranked link
- D. Cotter pin
- E. Outer link
- F. Circlip

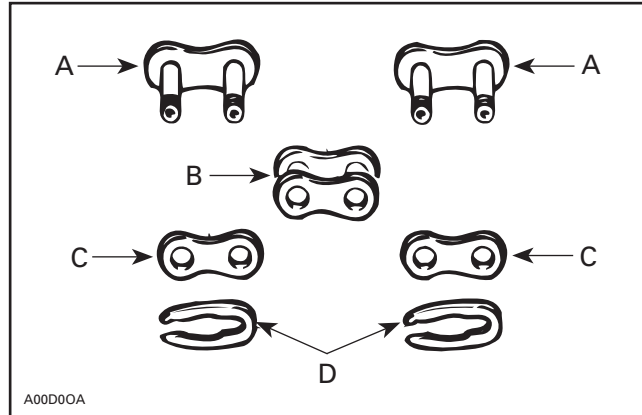

LENGTHENING 1 LINK

- A. Connecting link
- B. Inner link
- C. Outer link
- D. Circlip

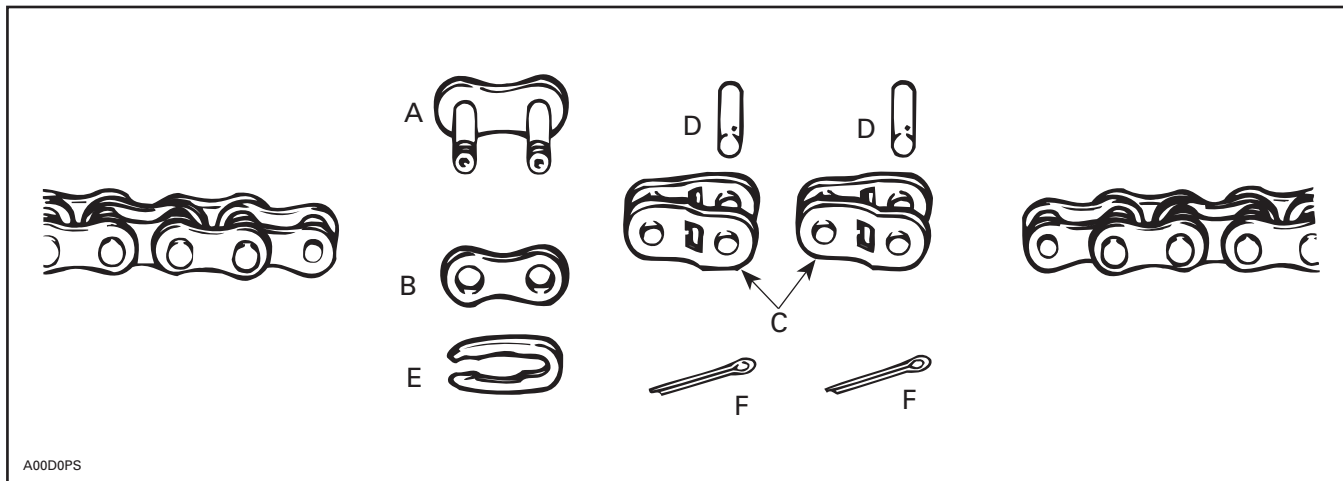

LENGTHENING 1-1/2 LINKS

- A. Connecting link
- B. Outer link
- C. Cranked link
- D. Link pin
- E. Circlip
- F. Cotter pin