

WIRING DIAGRAMS

MODELS	WIRING DIAGRAM PAGE	HEADLIGHT (watt)	TAILLIGHT (watt)	ELECTRICAL SYSTEM OUTPUT (watt)
Summit 600/700/800 RER	Annex 1	60/55 hal.	8/27	290
Summit 600/700/800	Annex 2	60/55 hal.	8/27	290
MX Z 500/600/700/800	Annex 3	60/55 hal.	8/27	290
MX Z 500/600/700/800 RER	Annex 4	60/55 hal.	8/27	290
Legend 500/600/700/800	Annex 5	60/55 hal.	8/27	360
Grand Touring 500/600/700/800	Annex 6	60/55 hal.	8/27	360
Legend Fan 380/500, Grand Touring Fan 380/500, MX Z Fan 380/500, Summit Fan 500	Annex 7	60/55 hal.	8/27	300

hal. = halogen

WIRING DIAGRAM LEGEND

⚠ WARNING

Ensure all terminals are properly crimped on the wires and all connector housings are properly fastened.

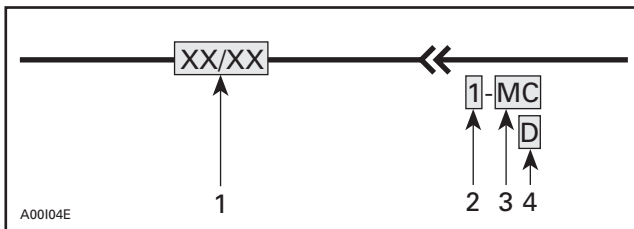

1. Wire colors
2. Connector housing area
3. Housing code per area
4. Wire connector location in housing

WIRE COLORS

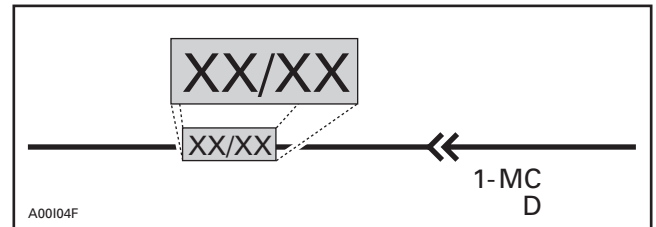

The first color of a wire is the main color, second color is the stripe.

Example: YL/BK is a YELLOW wire with a BLACK stripe.

COLOR CODE					
BE	-	BEIGE	OR	-	ORANGE
BK	-	BLACK	RD	-	RED
BU	-	BLUE	VI	-	VIOLET
BR	-	BROWN	WH	-	WHITE
GN	-	GREEN	YL	-	YELLOW
GY	-	GREY			

Section 11 WIRING DIAGRAMS

Subsection 01 (WIRING DIAGRAMS)

CONNECTOR HOUSING AREA

The first digit of the connector identification number presents the location of the connector on the vehicle.

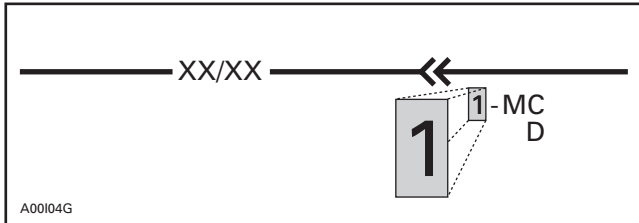

The following illustration shows the snowmobile with number on it. These numbers will correspond with the locations of the connector on the vehicle along with a brief description.

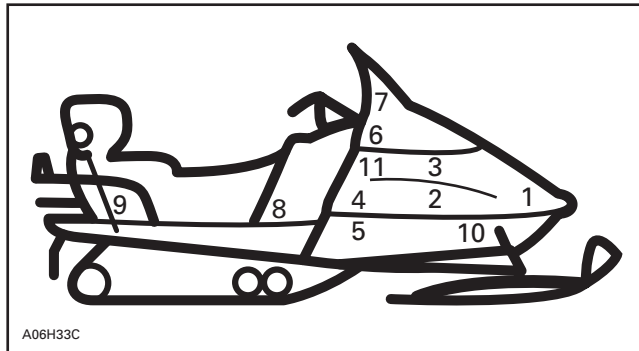

AREA	LOCATION
1	Front of engine compartment
2	Magneto
3	Carburetors
4	Near of intake silencer
5	Near driven pulley
6	Under console
7	Under hood
8	Near fuel tank
9	Rear of seat
10	Under engine
11	On injection oil reservoir

HOUSING REFERENCE PER AREA

The next two letters of the connector identification number represents a connector reference. If there are many connectors in the same area this helps identify which wire is in which connector.

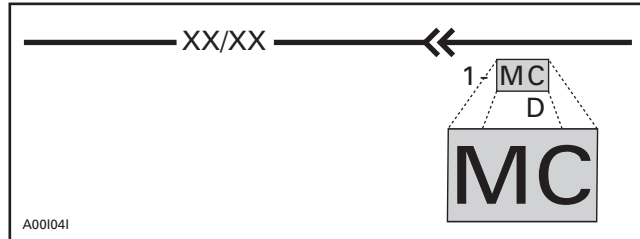

WIRE LOCATION IN CONNECTOR HOUSING

The third portion of the connector identification number represents the location of the wire in the connector housing. This could be identified by either a number such as 1, 2, 3 or by a letter such as A, B, C depending on the type of connector used.

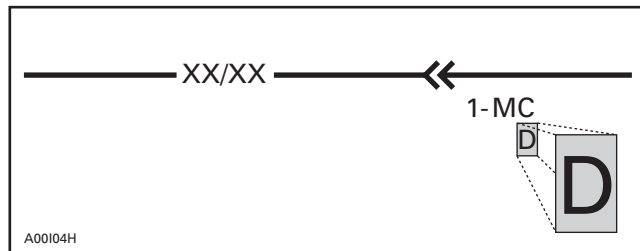

Section 11 WIRING DIAGRAMS



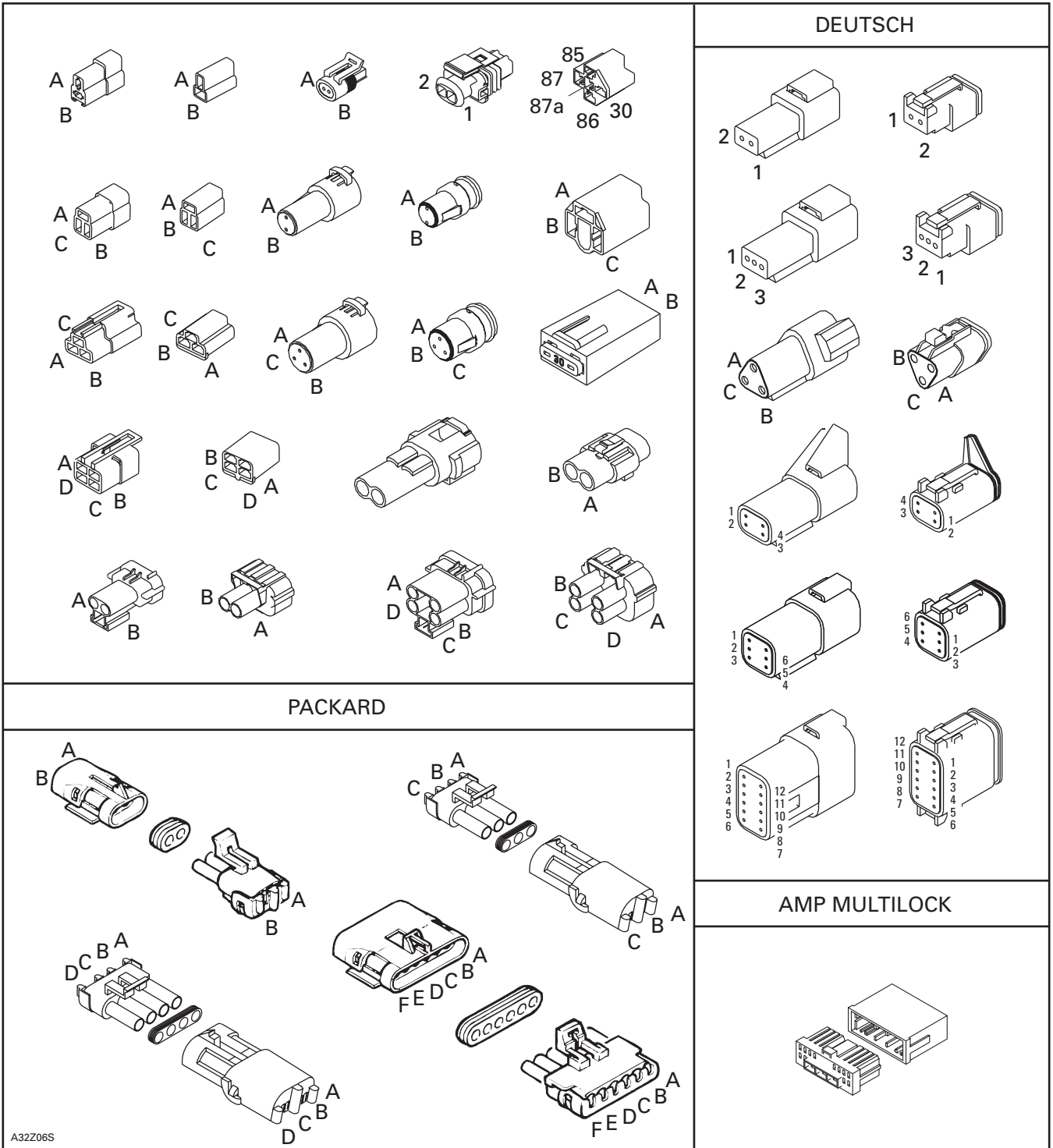







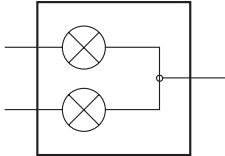



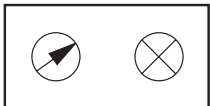

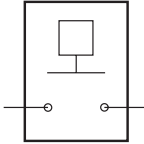
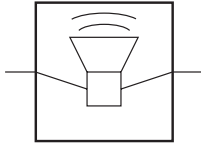

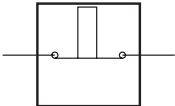
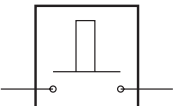

Subsection 01 (WIRING DIAGRAMS)

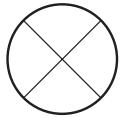
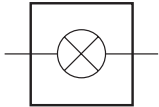
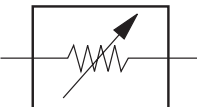
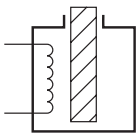

A32Z06S

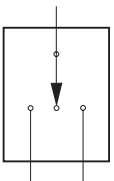
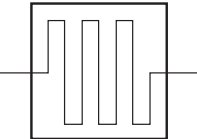
Section 11 WIRING DIAGRAMS
 Subsection 01 (WIRING DIAGRAMS)

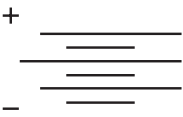
SYMBOLS DESCRIPTION

<p>Beam and tail light</p> 	<p>Female terminal</p> 	<p>Male terminal</p> 	<p>Electronic module</p> 
<p>Meter</p> 	<p>Electric motor</p> 	<p>Low level sensor</p> 	<p>Buzzer</p> 
<p>Ignition coil</p> 	<p>Normally close switch</p> 	<p>Normally open switch</p> 	<p>Male terminal on instrument</p> 
<p>Engine ground</p> 	<p>Frame ground</p> 	<p>Spark plug</p> 	<p>Meter movement</p> 
<p>Bulb</p> 	<p>Pilot</p> 	<p>Analog sensor</p> 	<p>Solenoid valve</p> 
<p>Magneto (Delta)</p> 	<p>3 position switch</p> 	<p>Heating element</p> 	<p>Fuse</p> 
<p>Trigger coil</p> 	<p>Battery</p> 	<p>Diode</p> 	<p>Partially illustrated component</p> 

A00E9PS

UNPLUGGING CONNECTORS

Always unplug connectors by pulling on housing not on wire.

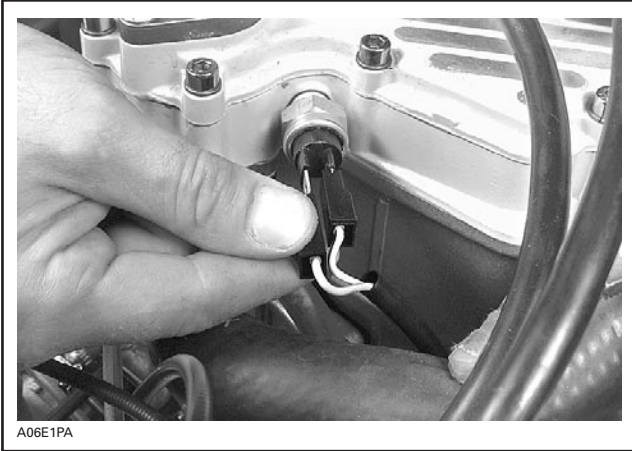

TYPICAL

TAB AND RECEPTACLE CONNECTORS REMOVAL

Tab Connector

It is locked in its housing by a spring tab on its side. Removal is done by squeezing this tab.

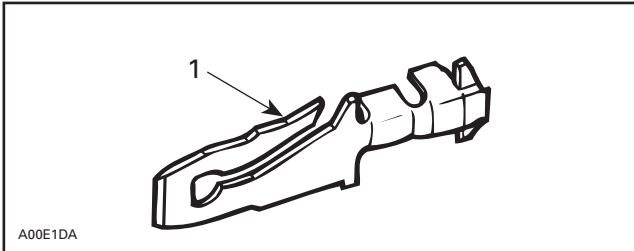

TAB CONNECTOR

1. Locking tab

To remove:

- Insert a screwdriver or Snap-on TT 600-5 from opposite side of wire and pry locking tab.
- While holding locking tab pried, pull connector toward wire side.

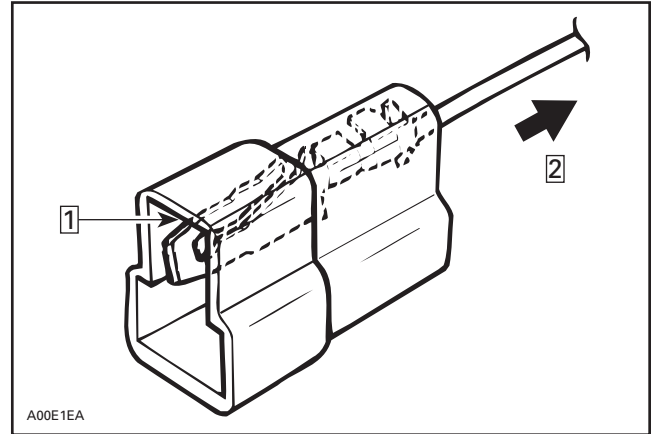

Step 1: Insert screwdriver here

Step 2: Pull this side

Locking Receptacle Connector

To remove:

- Insert tool Snap-on TT 600-5 in access opening then pull housing toward wire side.

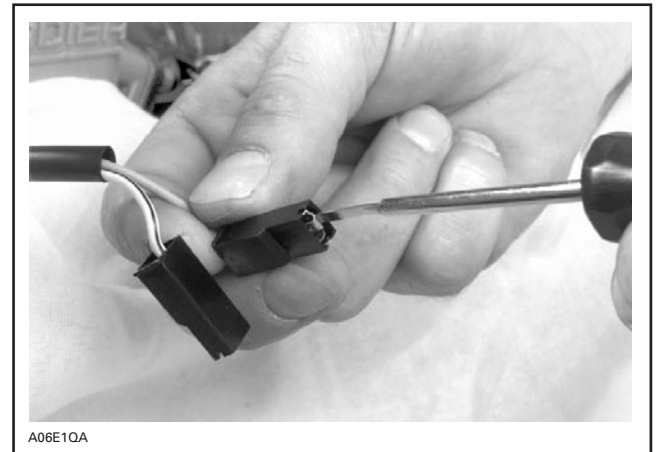

Section 11 WIRING DIAGRAMS

Subsection 01 (WIRING DIAGRAMS)

Waterproof Connector Housing

Female Connector Housing

To remove:

- Insert tool Snap-on TT 600-5 under lock and twist to lift it.

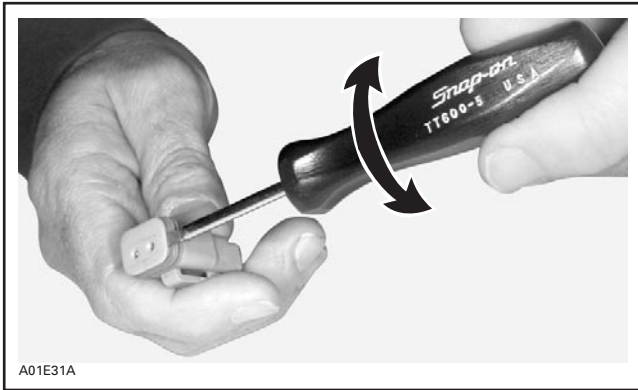

- Pry tab to free connector then pull wire out of housing.

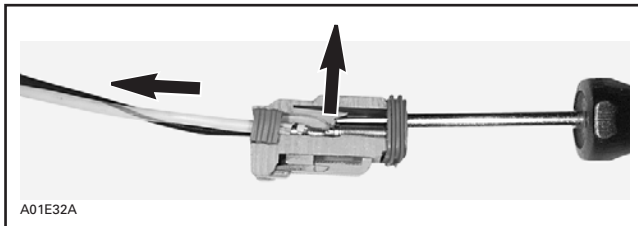

FEMALE CONNECTOR HOUSING — CUT-AWAY

Male Connector Housing

To remove:

- Using a small hook, pull out the lock.

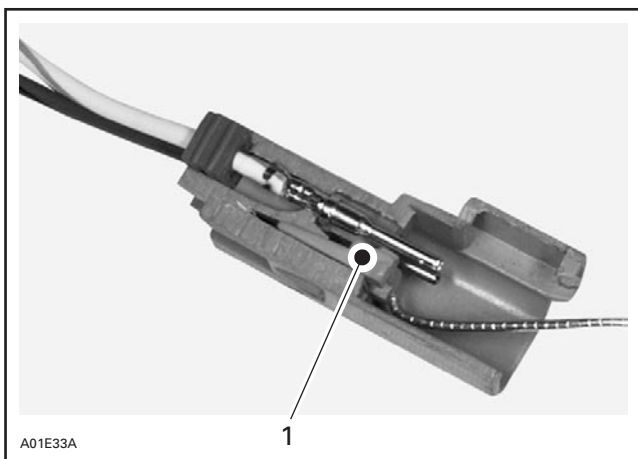

1. Lock

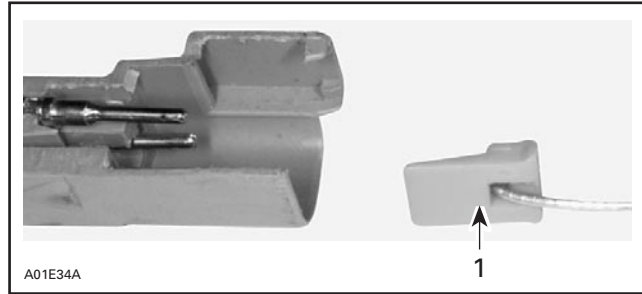

1. Lock

- Pry tab to free connector then pull wire out of housing.

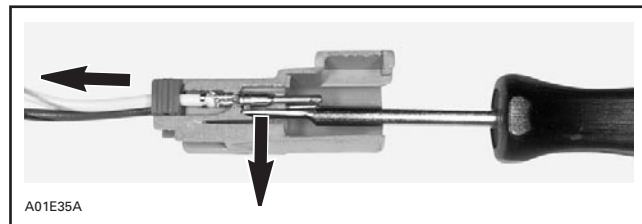

MALE CONNECTOR HOUSING — CUT-AWAY

Round Connector Housing

Female Connector Housing



Male Connector Housing

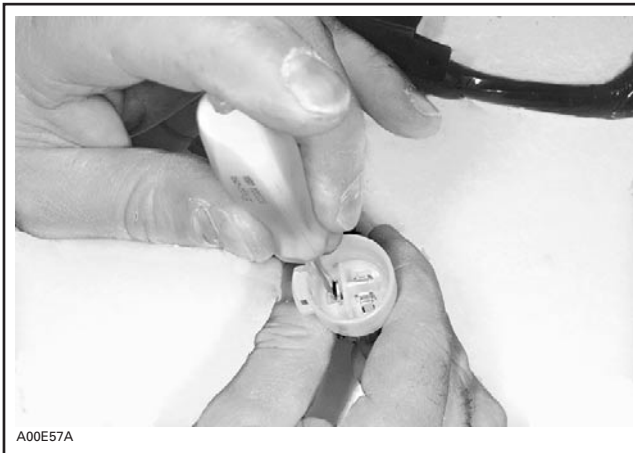

To remove:

- Insert tool AMP- 755430-2 under lock and twist to lift it.

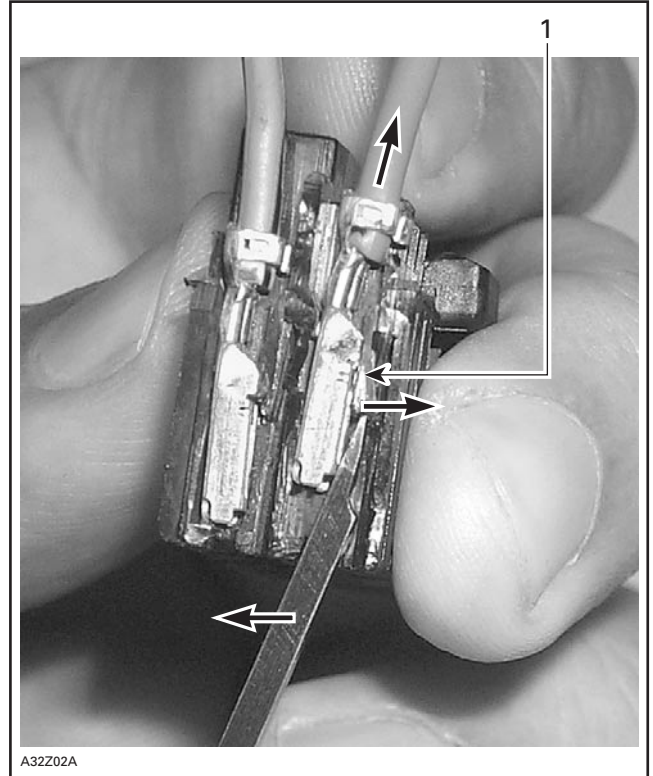

FEMALE CONNECTOR HOUSING — CUT-AWAY

1. Lock

Receptacle connectors can be removed from female housing with sharp head pin.

Multilock Connector Housing
Female Connector Housing

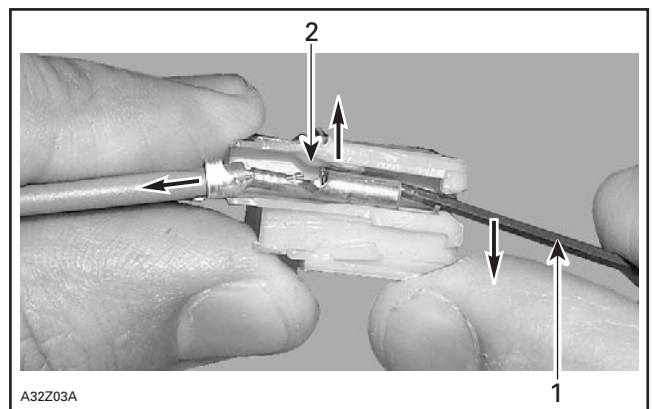
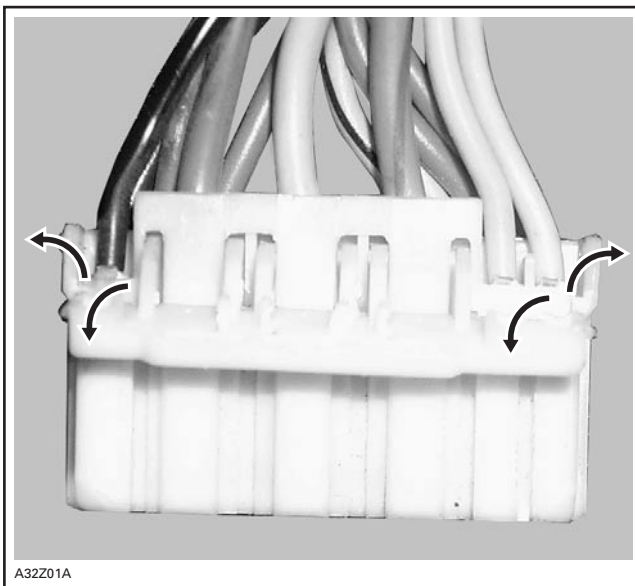

FEMALE CONNECTOR HOUSING — CUT-AWAY

1. Sharp head pin
2. Lock

Section 11 WIRING DIAGRAMS

Subsection 01 (WIRING DIAGRAMS)

Male Connector Housing

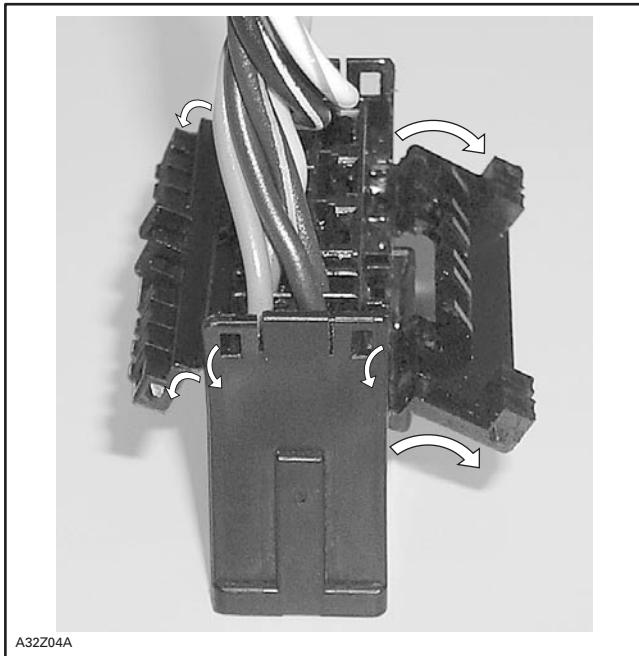

To remove:

- Insert tool AMP- 755430-2 under lock and twist to lift it.

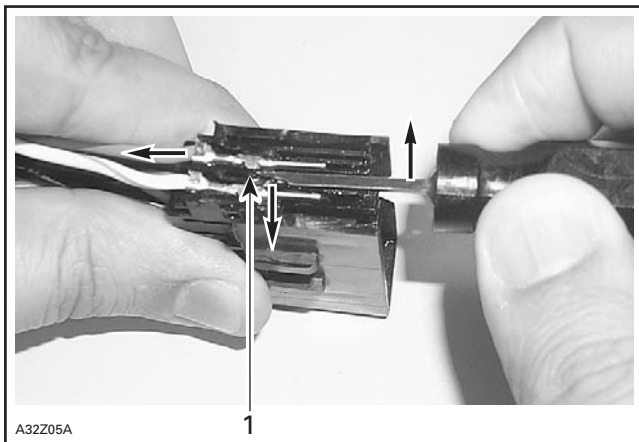

MALE CONNECTOR HOUSING — CUT-AWAY

1. Lock

TAB AND RECEPTACLE CONNECTORS INSTALLATION

Prior to installing, make sure locking tab is sufficiently lifted to properly lock.

Insert tab and receptacle connectors in their respective housings as shown in following illustrations. Push sufficiently so that they snap. Try pulling wire to ensure they are properly locked.

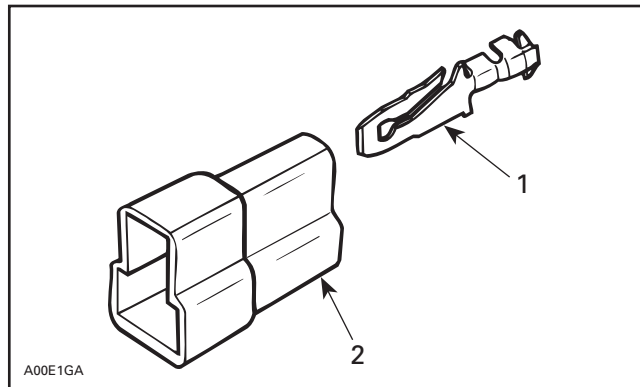

1. Tab
2. Housing

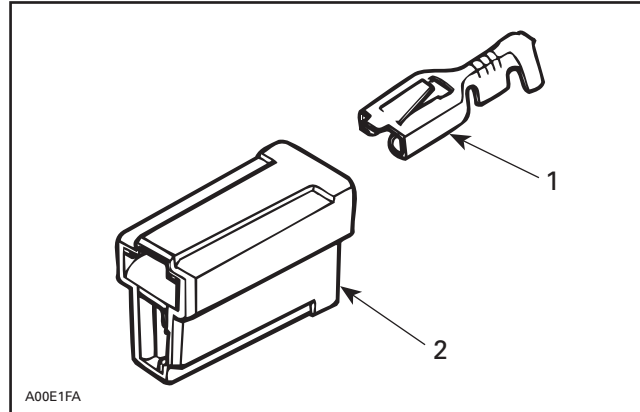

TYPICAL

1. Receptacle
2. Housing

ACCESSORIES INSTALLATION

On all **electric start models**: The direct current (DC) utilizes the snowmobile frame as ground "wire" while all alternating current (AC) consumers (lights, heated grips, fuel gauge, etc.) utilize a separate ground wire.

Never interconnect AC and DC grounds as an AC voltage drop will result. When installing accessories on **any** snowmobile, connect their wires directly to the YELLOW and YELLOW/BLACK lighting coil wires.

Even if **manual start models** have an AC ground to the chassis (on voltage regulator), all accessories utilize a ground wire isolated from chassis. When an electric starter kit is installed, the voltage regulator and its ground wire are replaced by a voltage rectifier/regulator unit permitting a completely isolated AC circuit.

WARNING

Keep wires away from any rotating, moving, heating, vibrating or sharp edge. Use proper fastening devices as required.

2002 GRAND TOURING 500/600/700/800

2002 GRAND TOURING 500/600/700/800

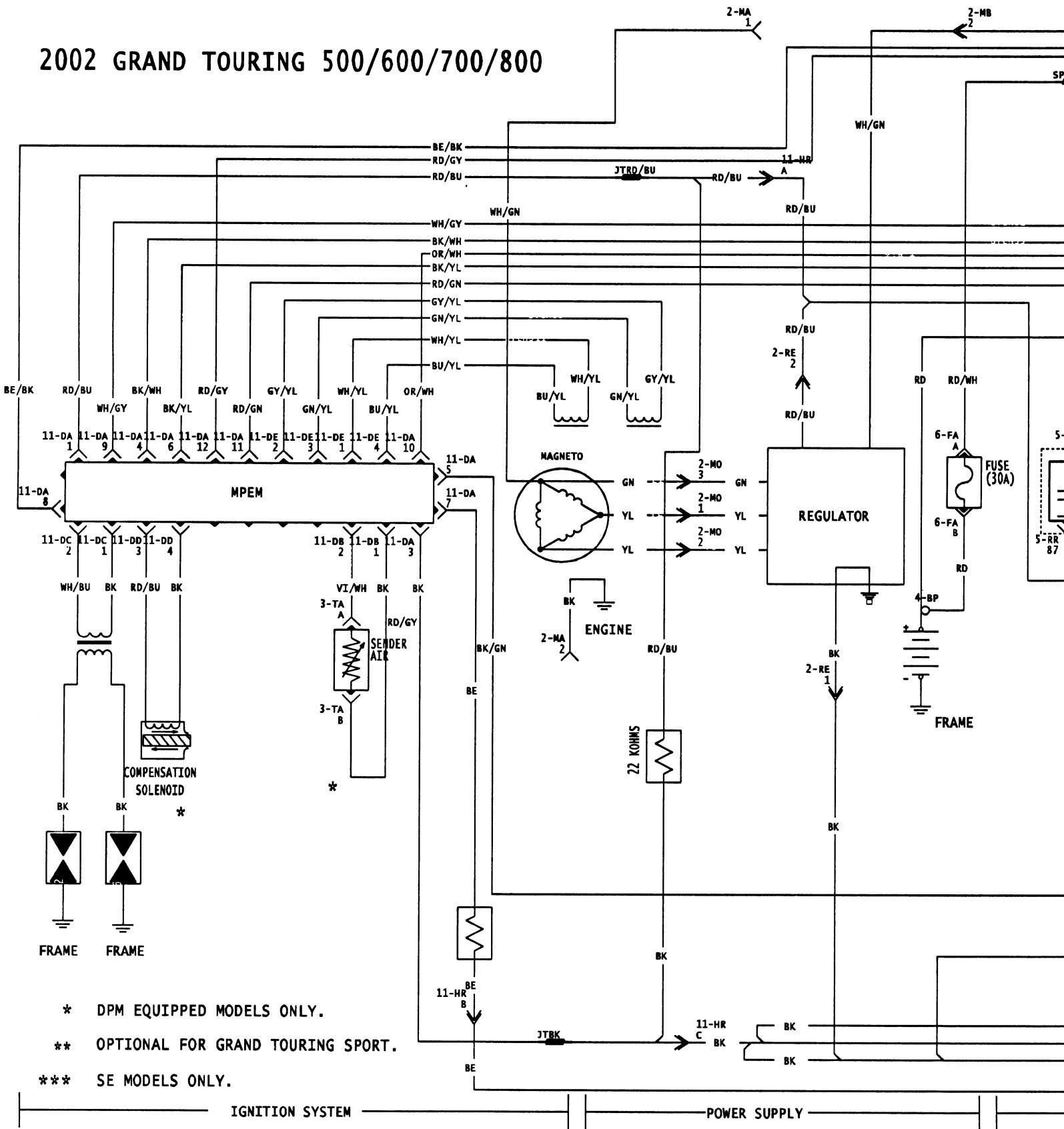

* DPM EQUIPPED MODELS ONLY.

** OPTIONAL FOR GRAND TOURING SPORT.

*** SE MODELS ONLY.

IGNITION SYSTEM

POWER SUPPLY

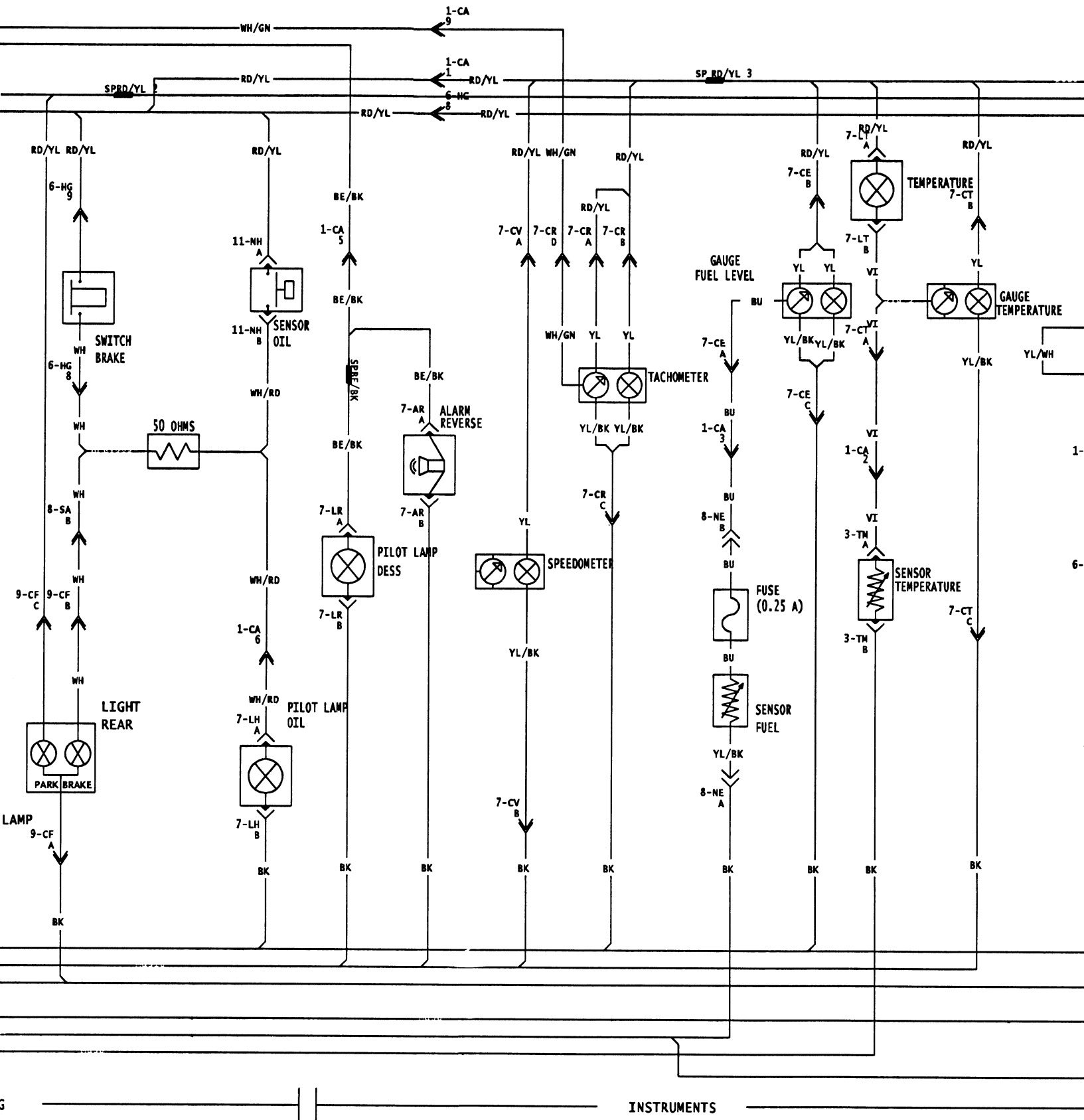

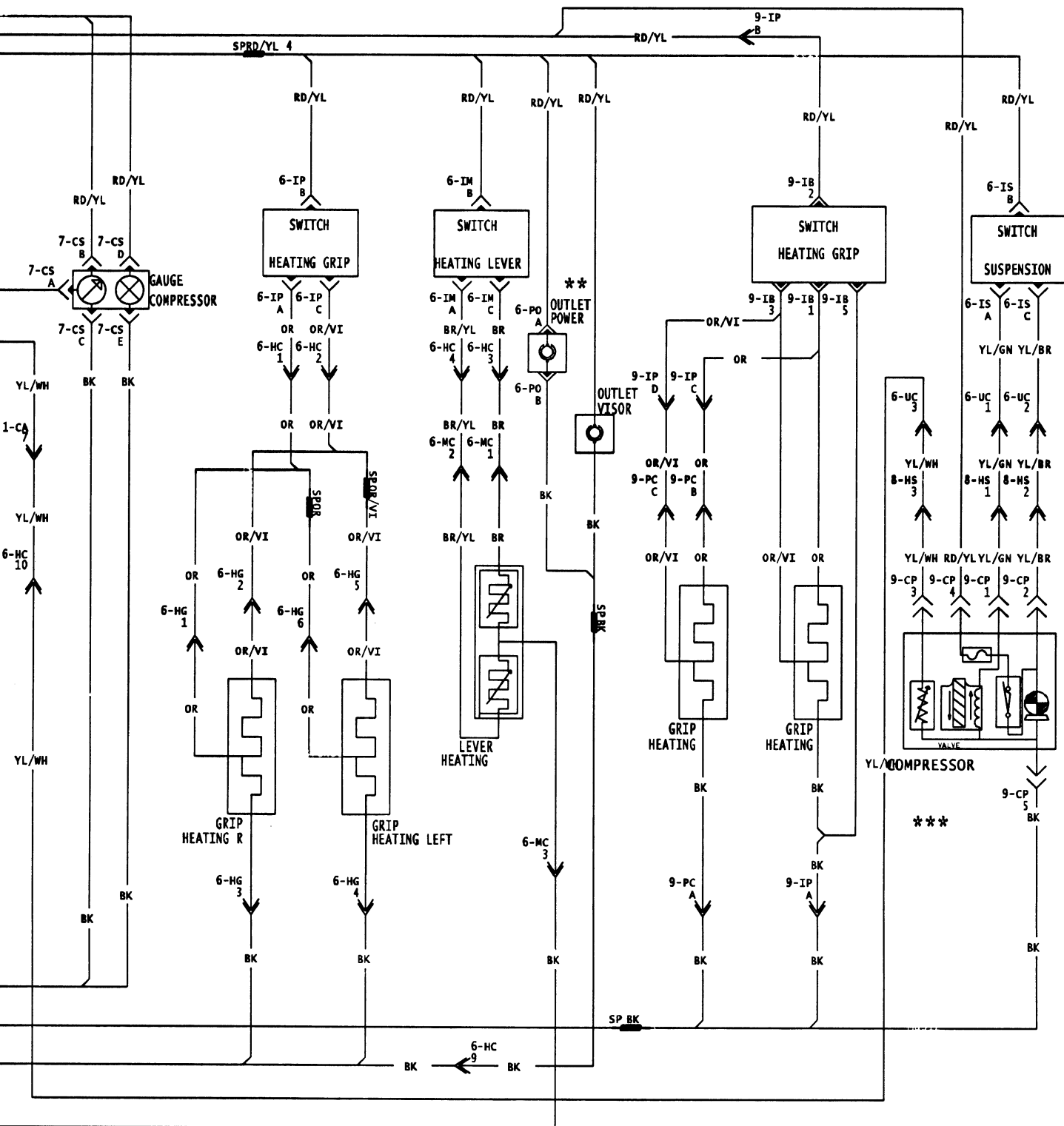

HEATING ELEMENTS

SUSPENSION OUTLET

2002 LEGEND 500/600/700/800

2002 LEGEND 500/600/700/800

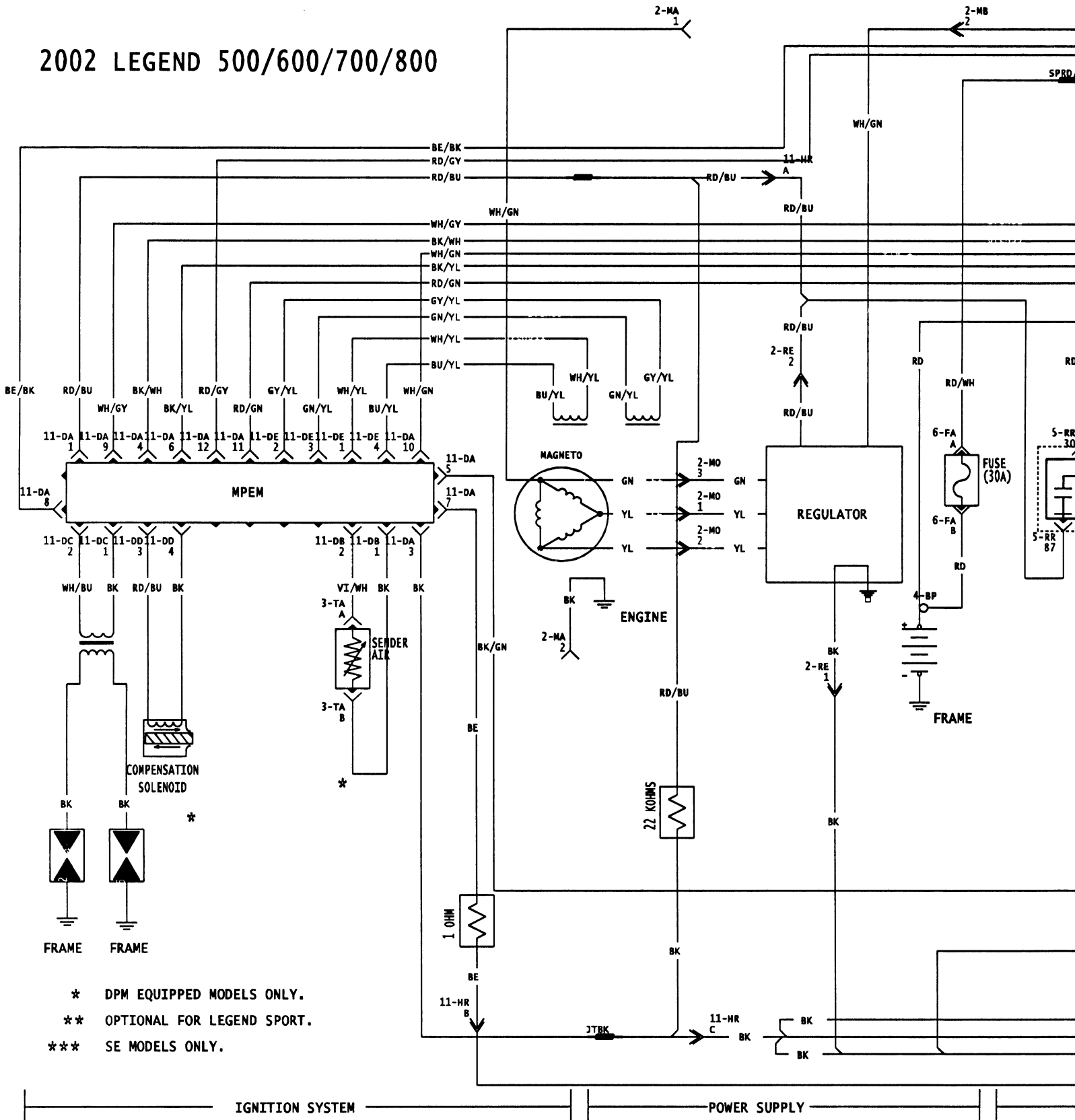

- * DPM EQUIPPED MODELS ONLY.
- ** OPTIONAL FOR LEGEND SPORT.
- *** SE MODELS ONLY.

IGNITION SYSTEM

POWER SUPPLY

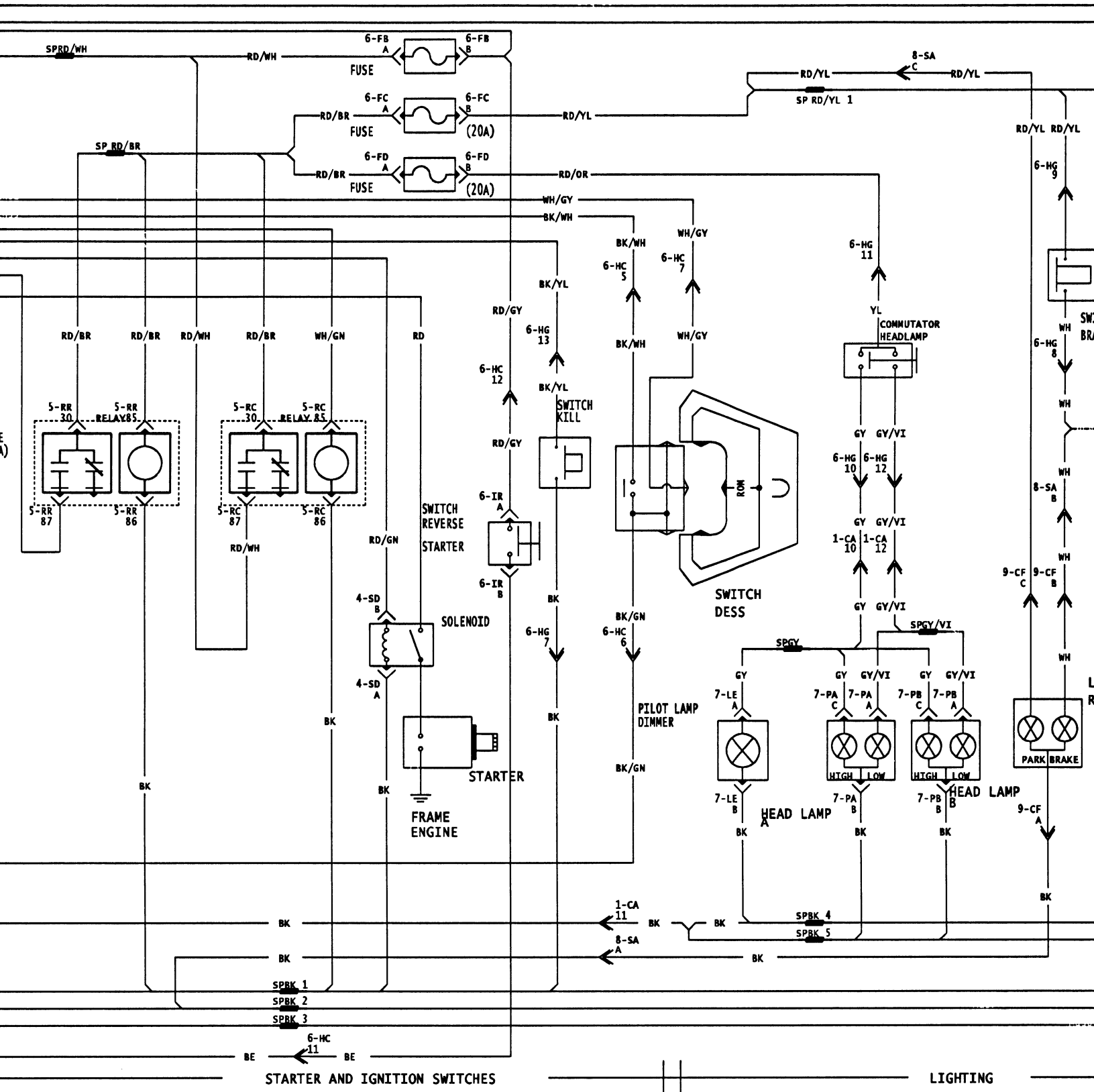

STARTER AND IGNITION SWITCHES

LIGHTING

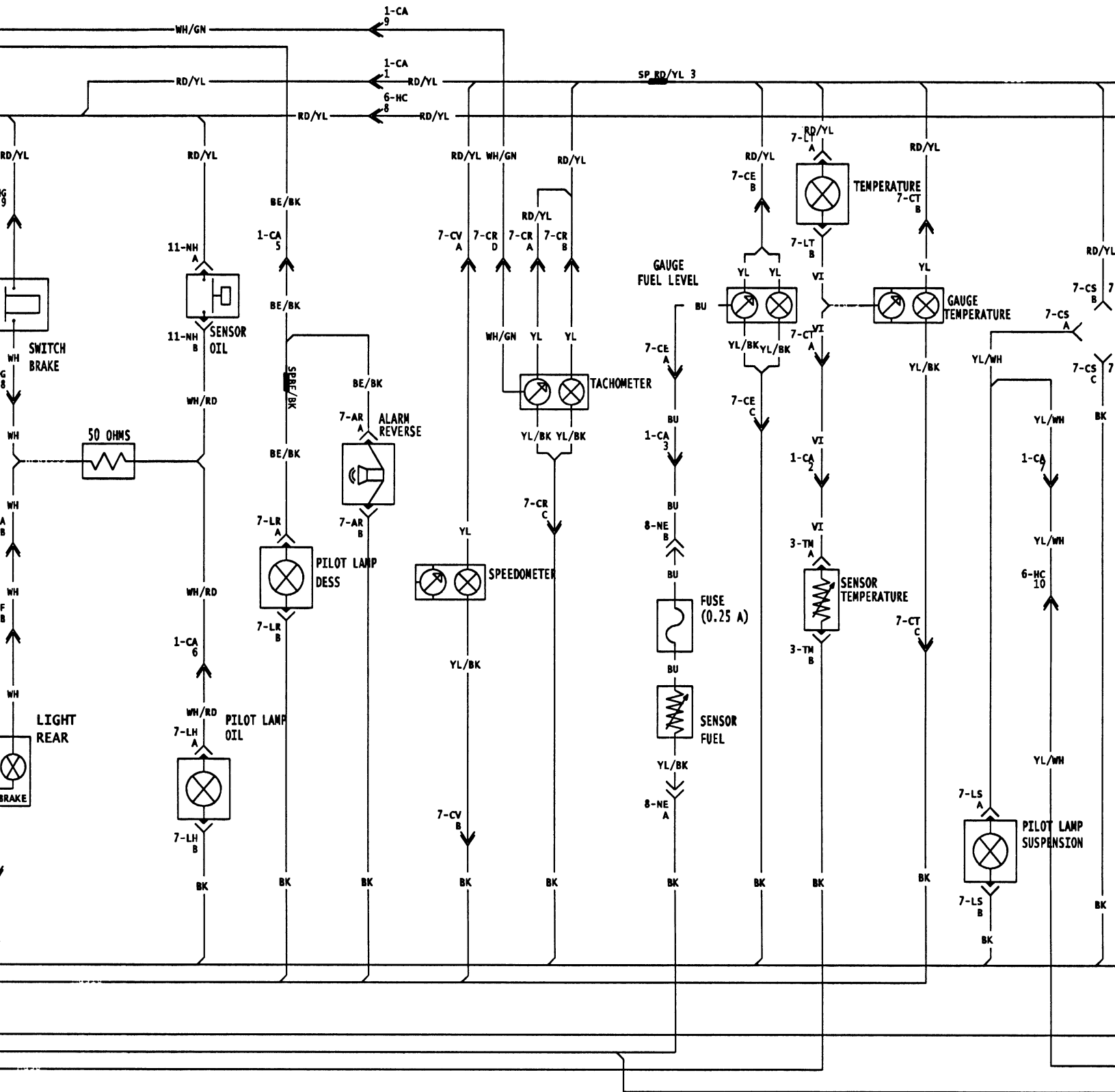

INSTRUMENTS

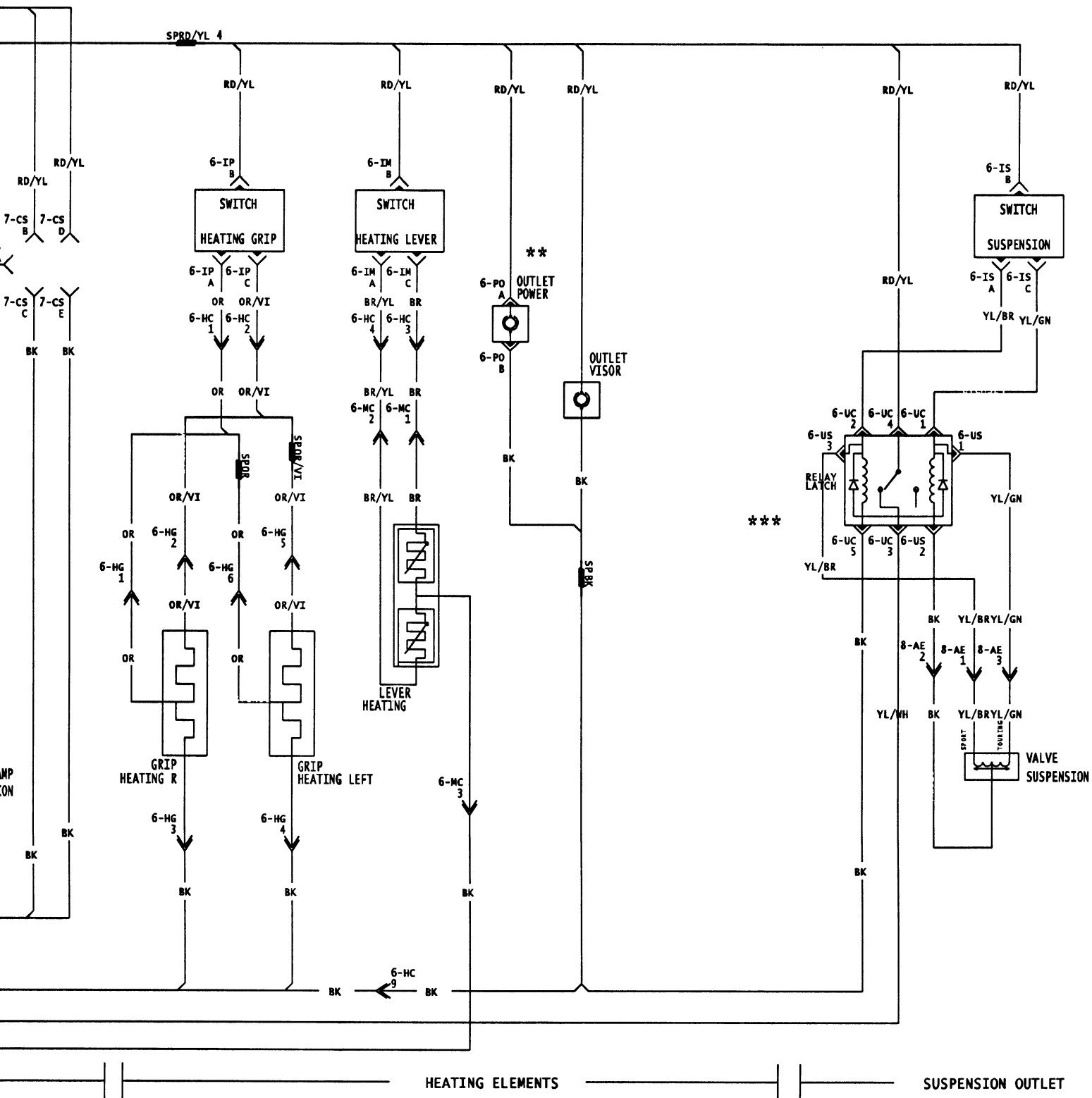

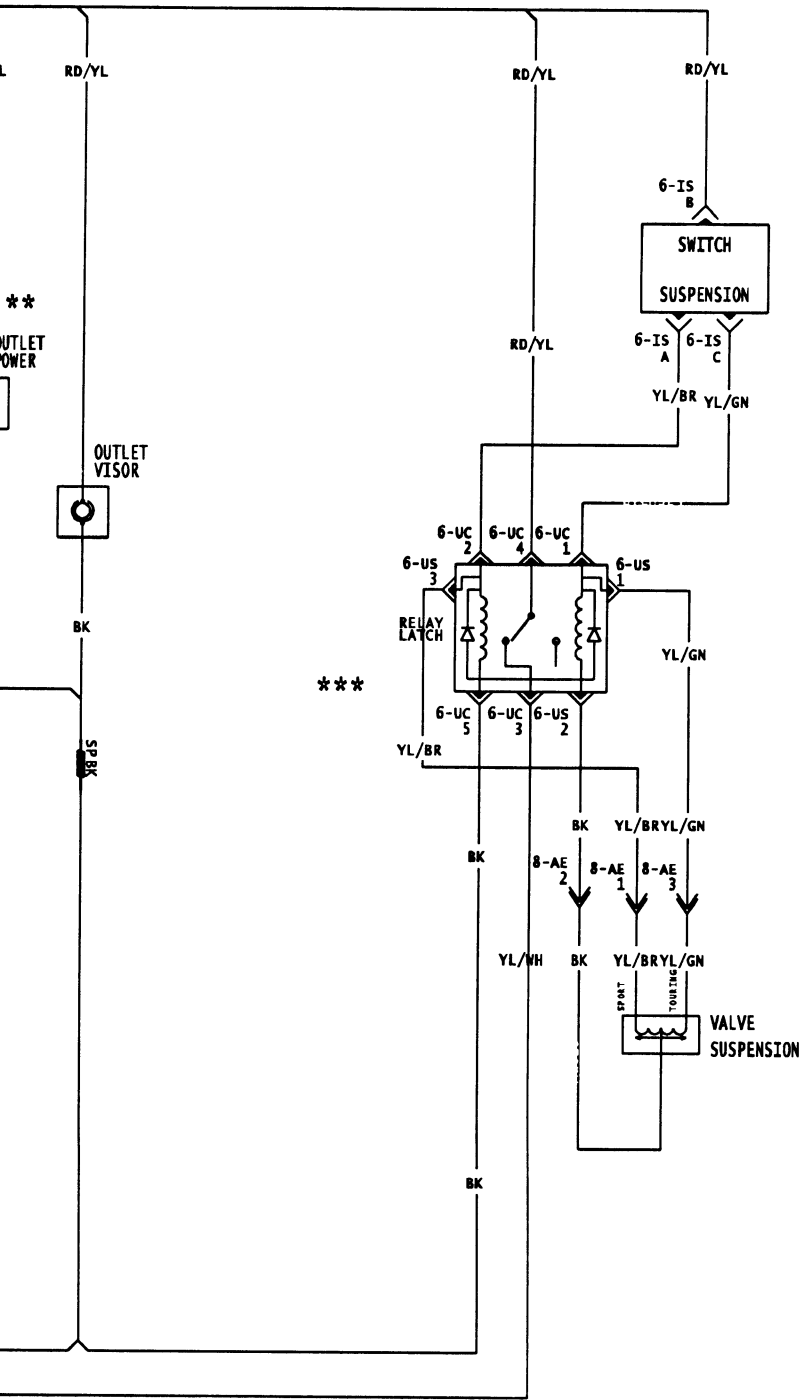

ENTS

SUSPENSION OUTLET

2002 LEGEND FAN 380/500,
GRAND TOURING FAN 380/500,
MX Z FAN 380/500,
SUMMIT FAN 500

2002 LEGEND FAN 380/500, GR. TOURING FAN 380/500, MX Z FAN 380/500, S

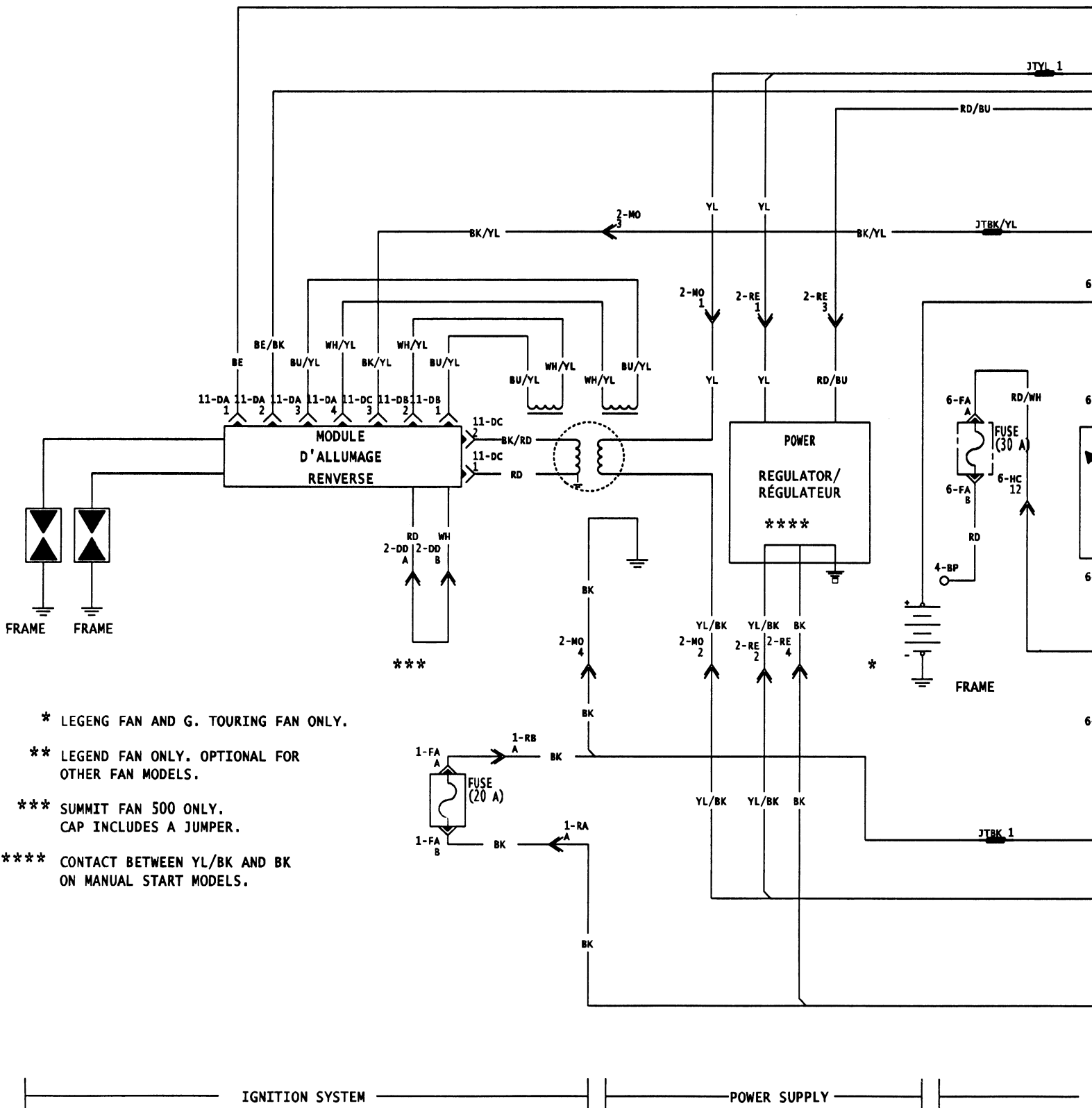

IGNITION SYSTEM

POWER SUPPLY

SUMMIT FAN 500

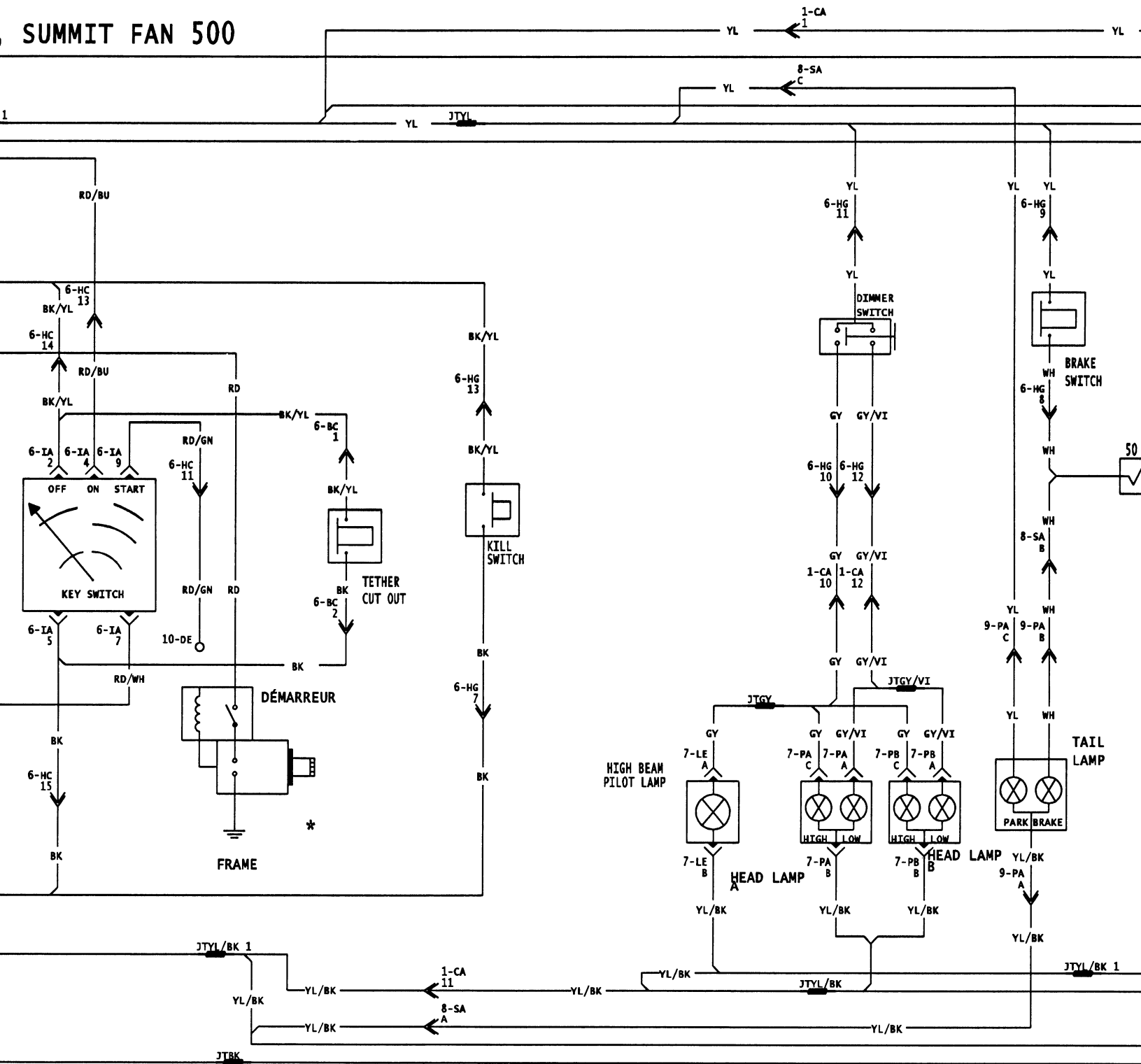

STARTER AND IGNITION SWITCHES

LIGHTING

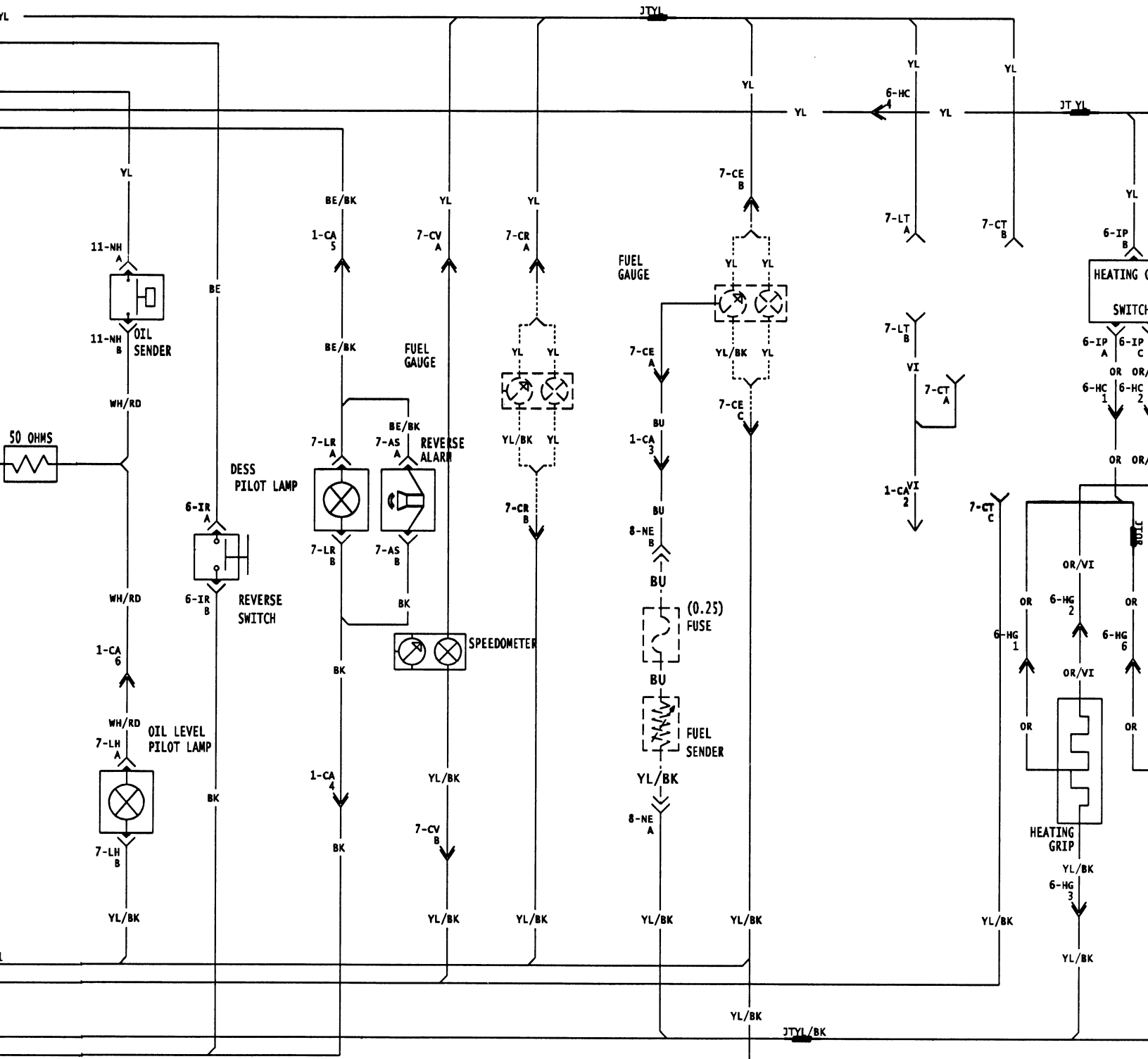

INSTRUMENTS

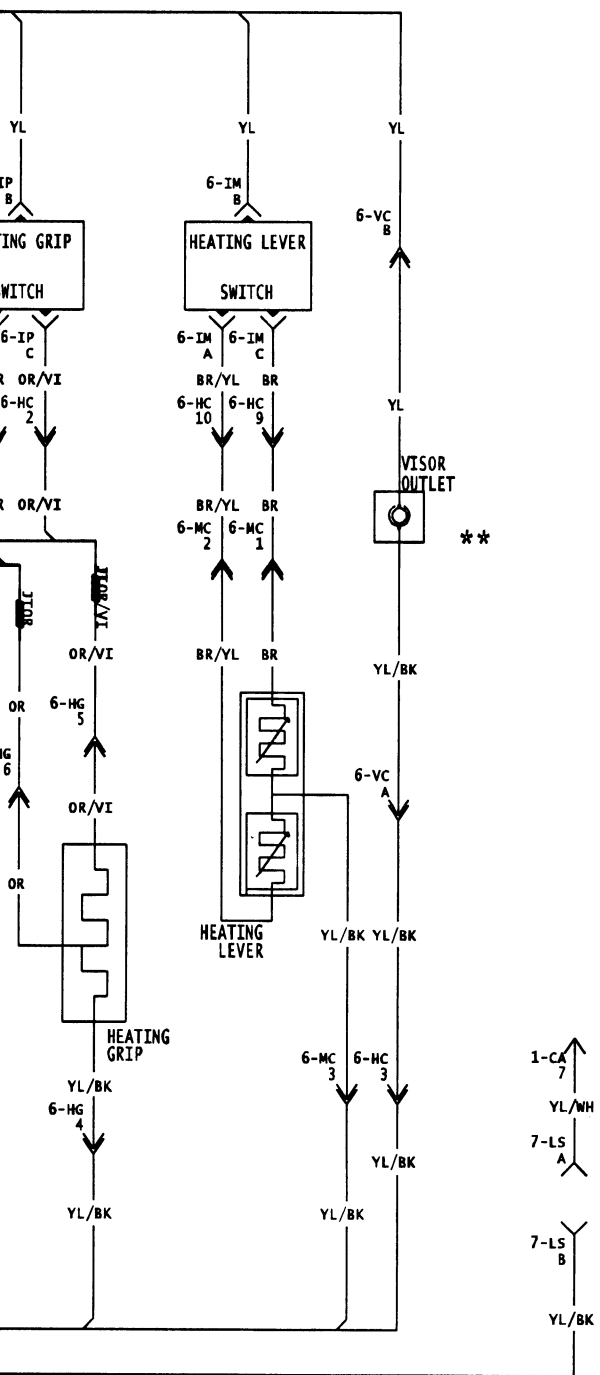

HEATING ELEMENTS

2002 MX Z 500/600/700/800

2002 MX Z 500/600/700/800

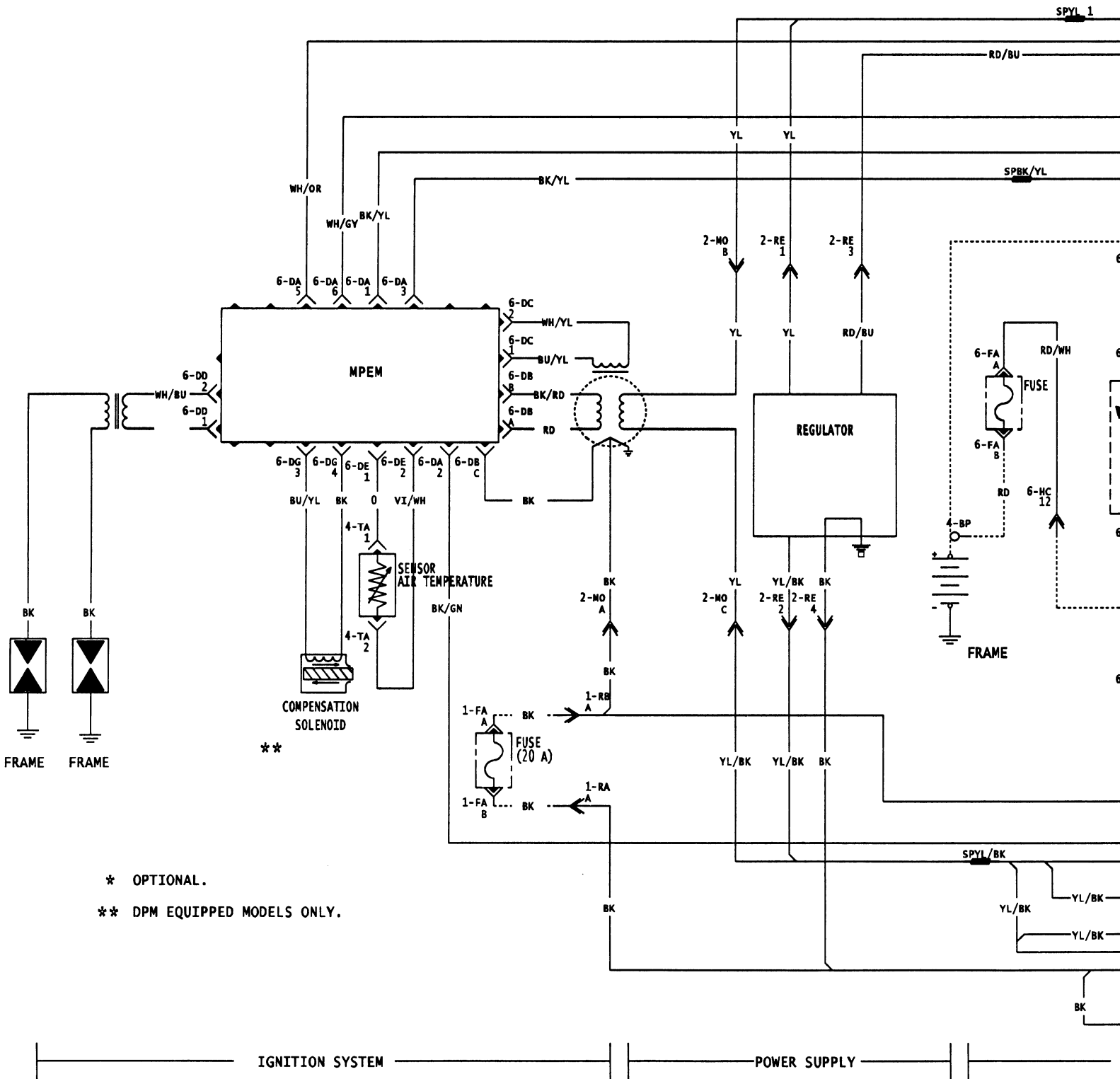

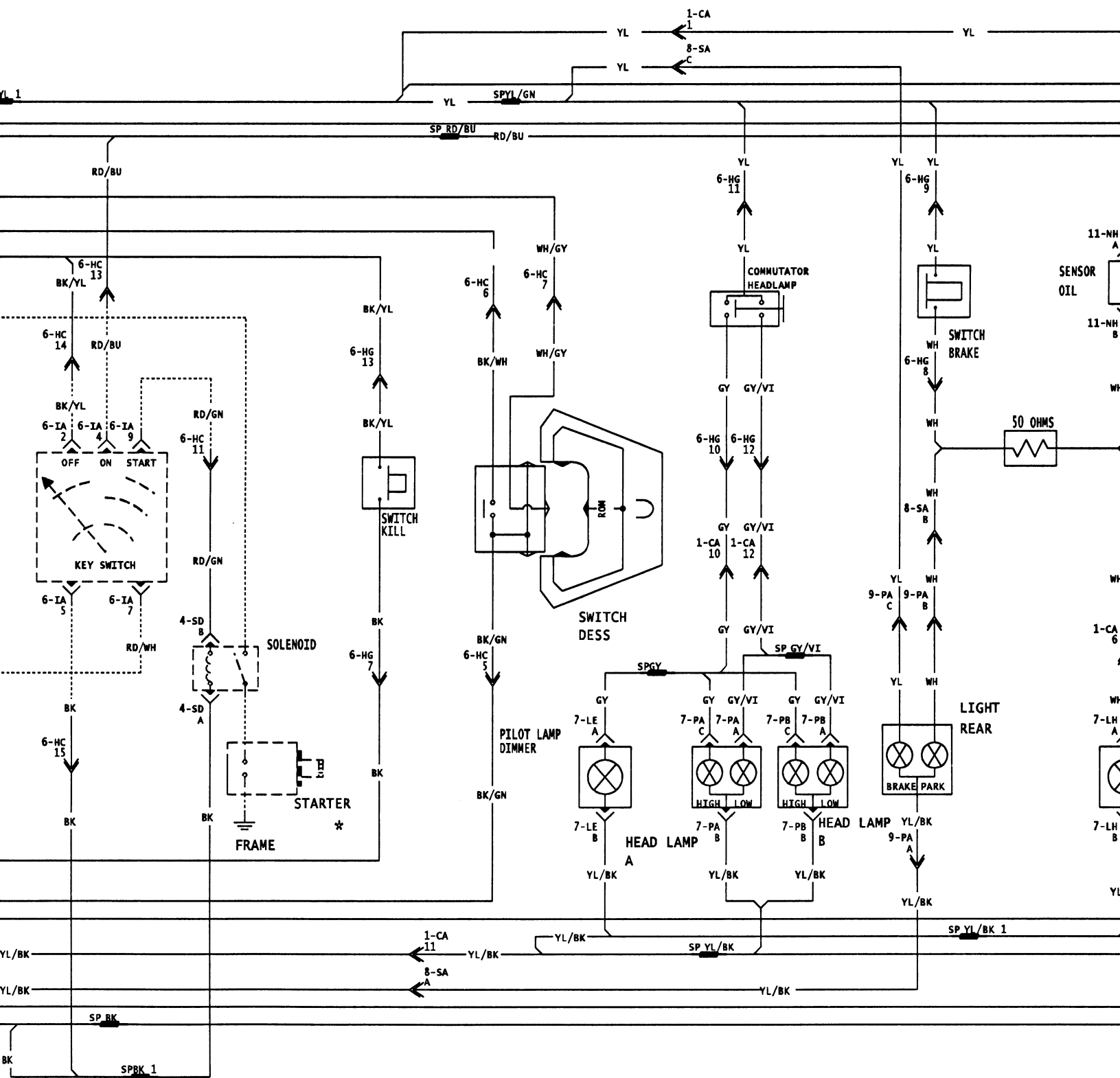

STARTER AND IGNITION SWITCHES

LIGHTING

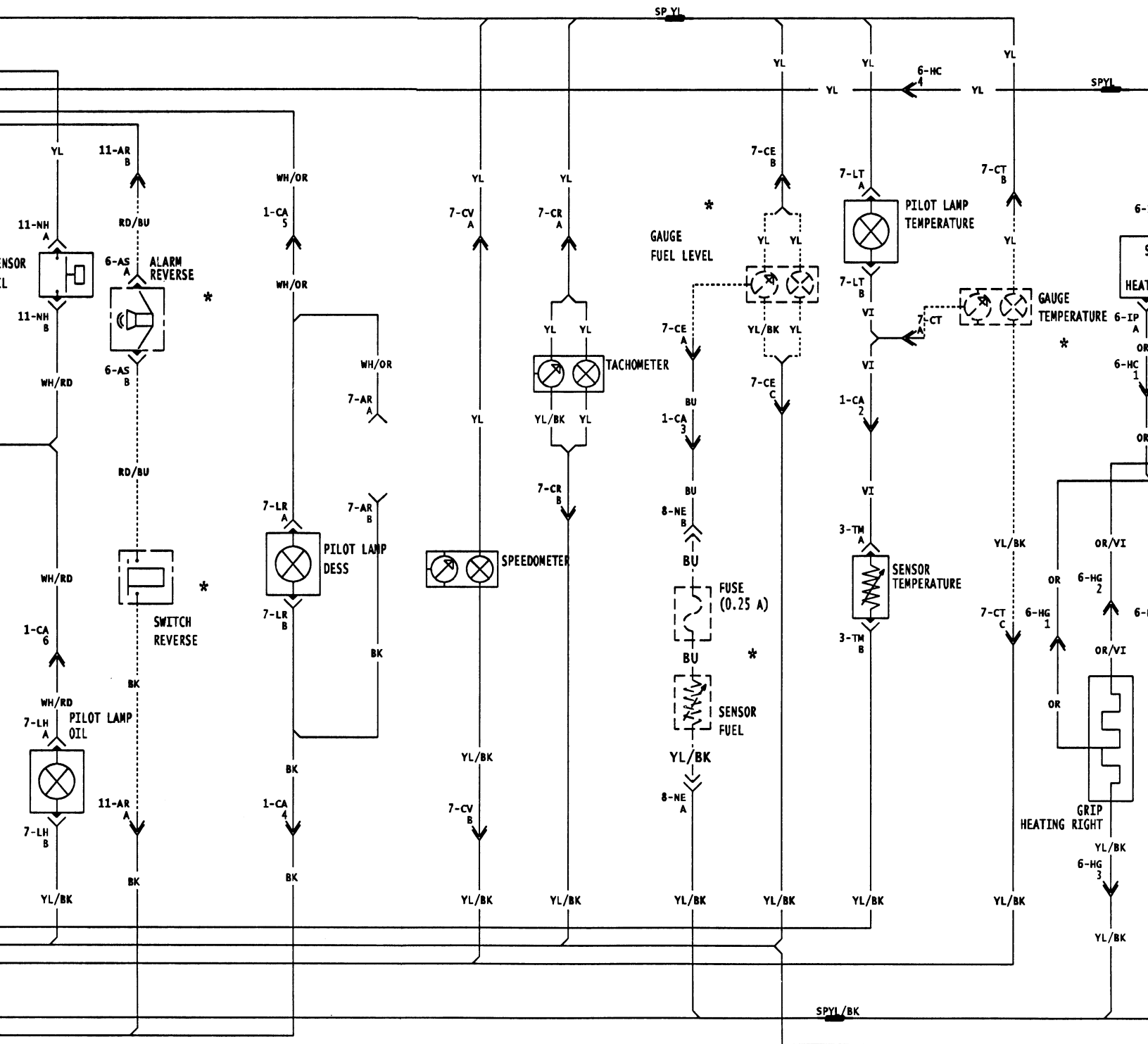

INSTRUMENTS

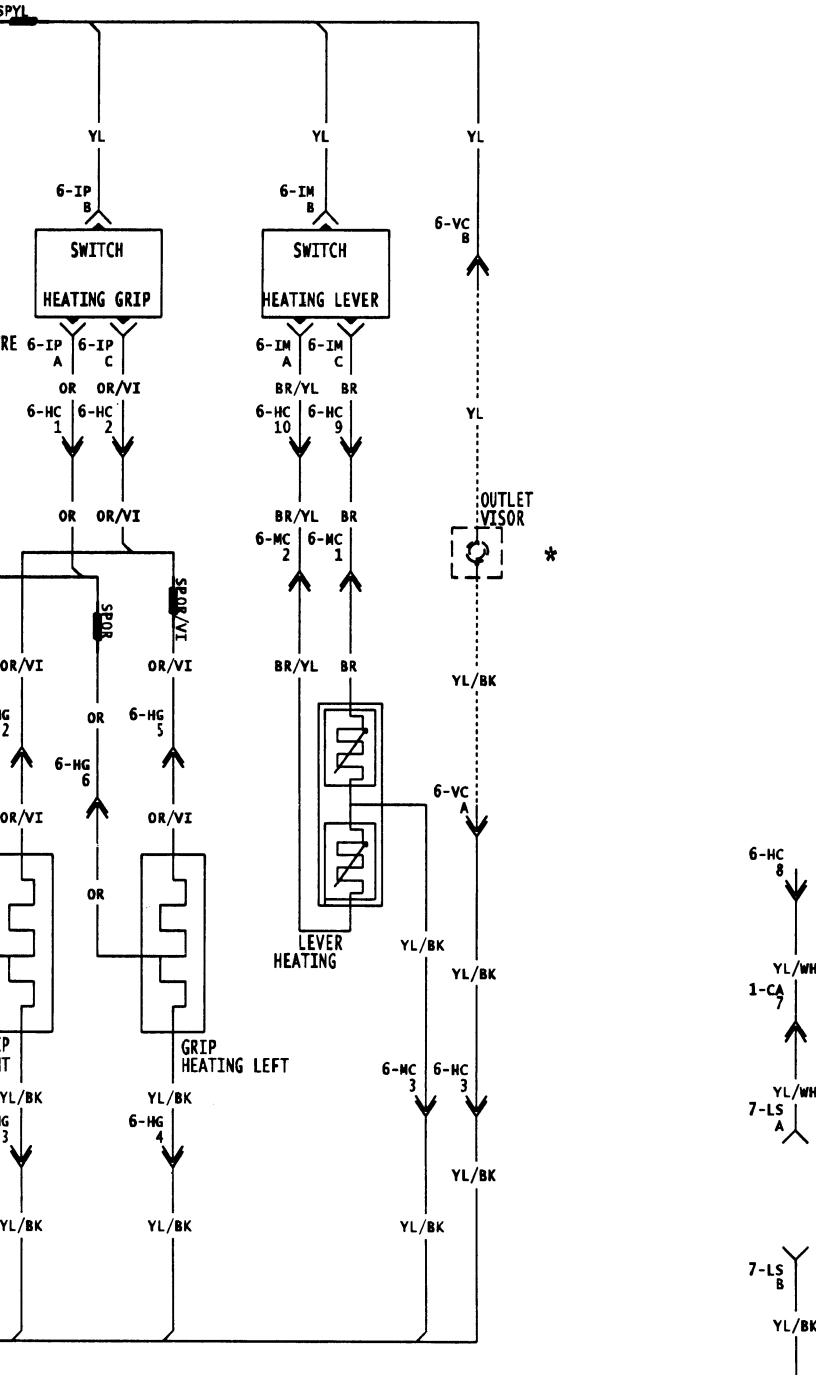

HEATING ELEMENTS

SUSPENSION OUTLET

2002 MX Z 500/600/700/800 RER

2002 MX Z 500/600/700/800 RER

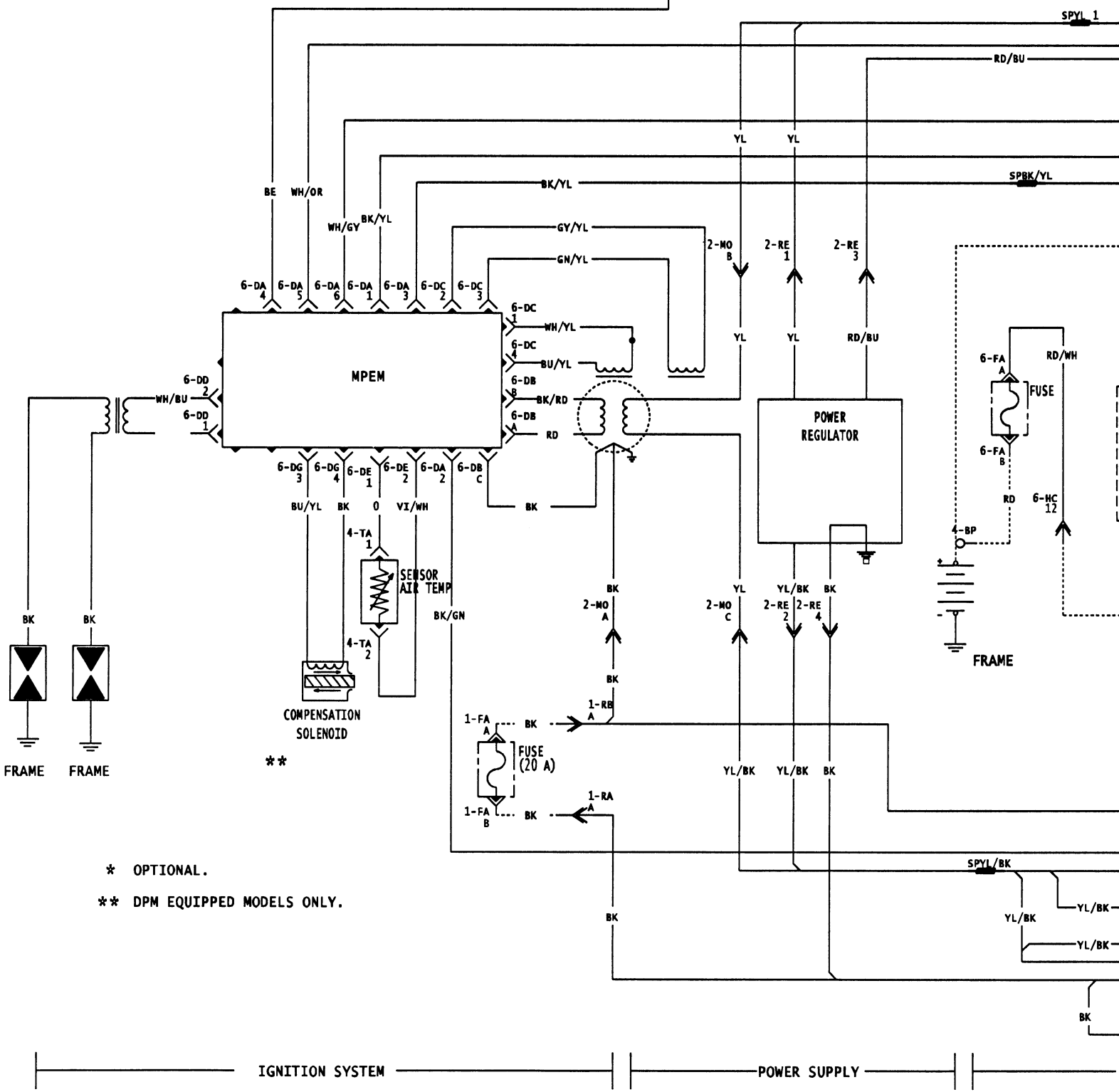

* OPTIONAL.

** DPM EQUIPPED MODELS ONLY.

IGNITION SYSTEM

POWER SUPPLY

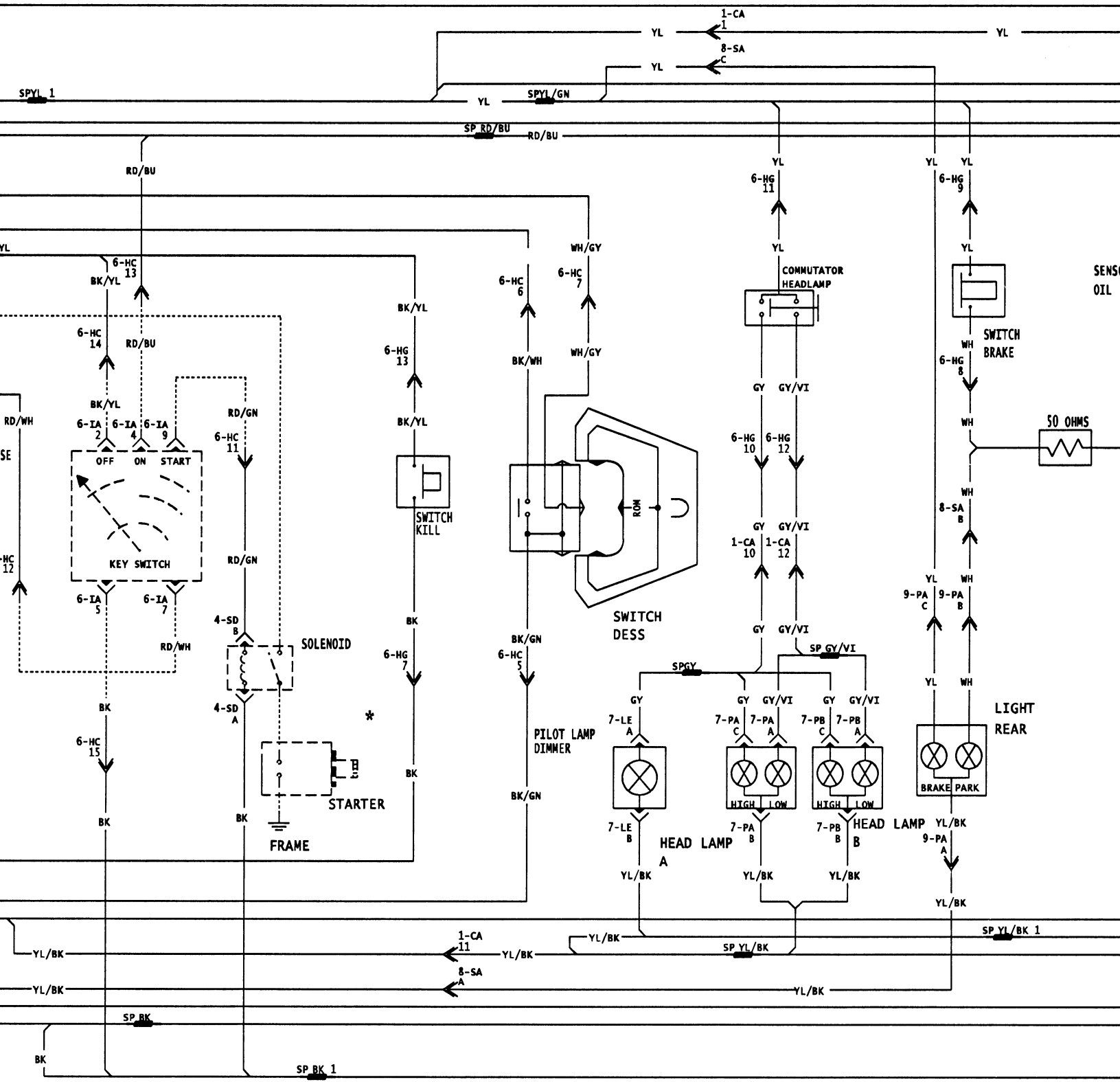

STARTER AND IGNITION SWITCHES

LIGHTING

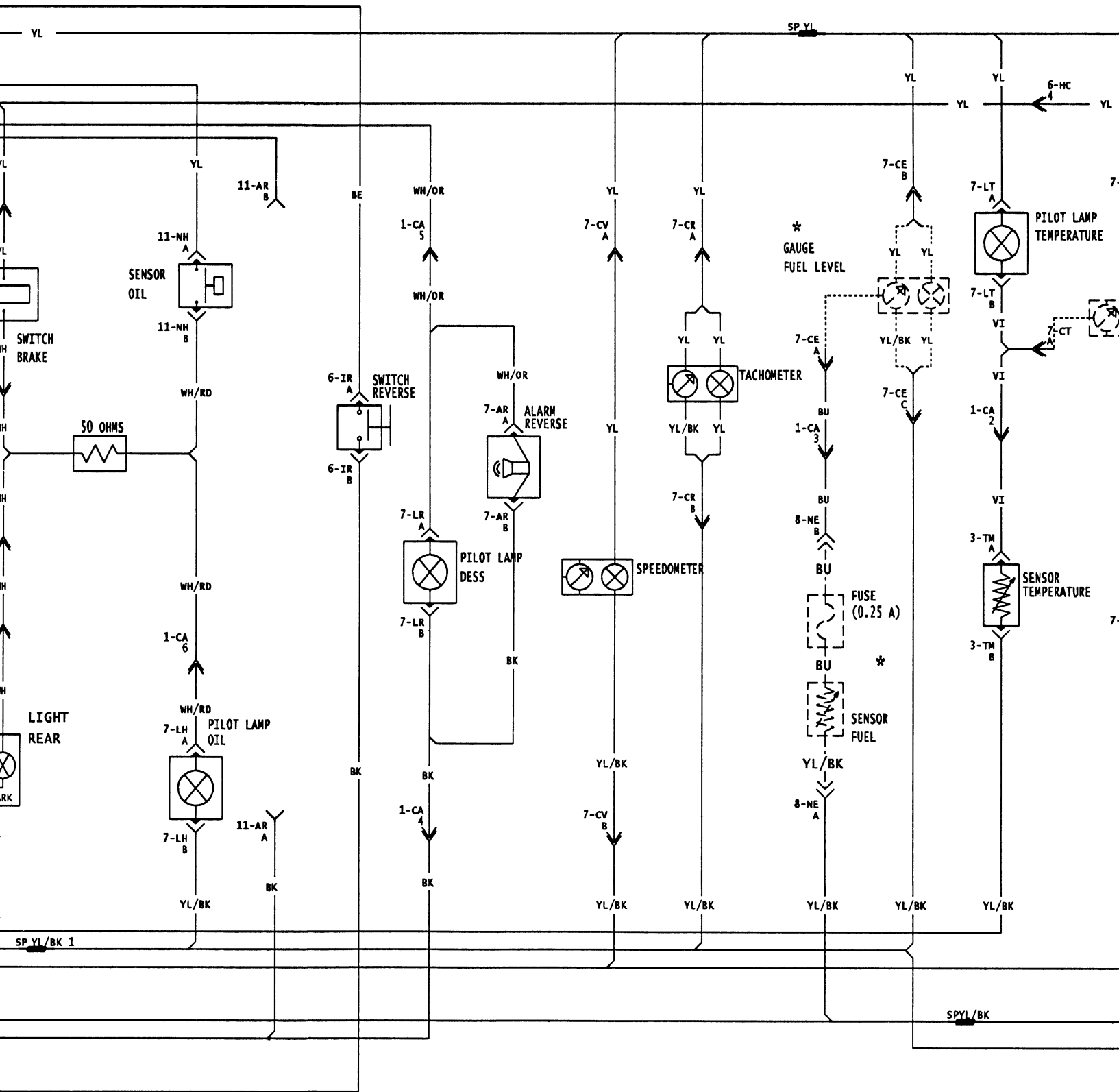

INSTRUMENTS

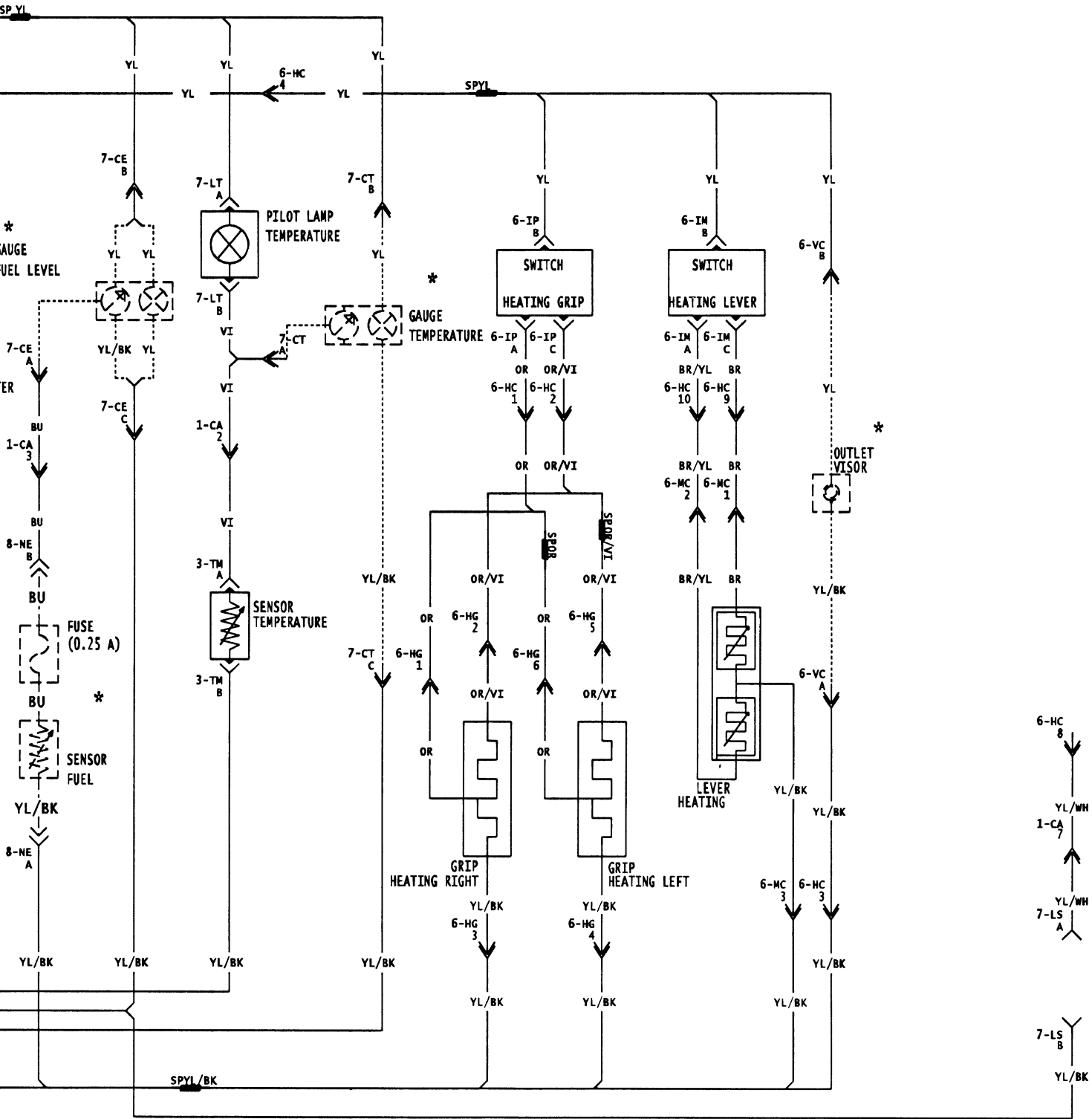

HEATING ELEMENTS

SUSPENSION OUTLET

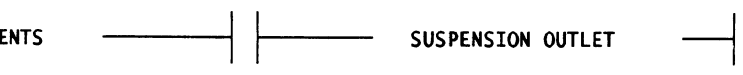
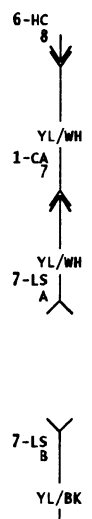
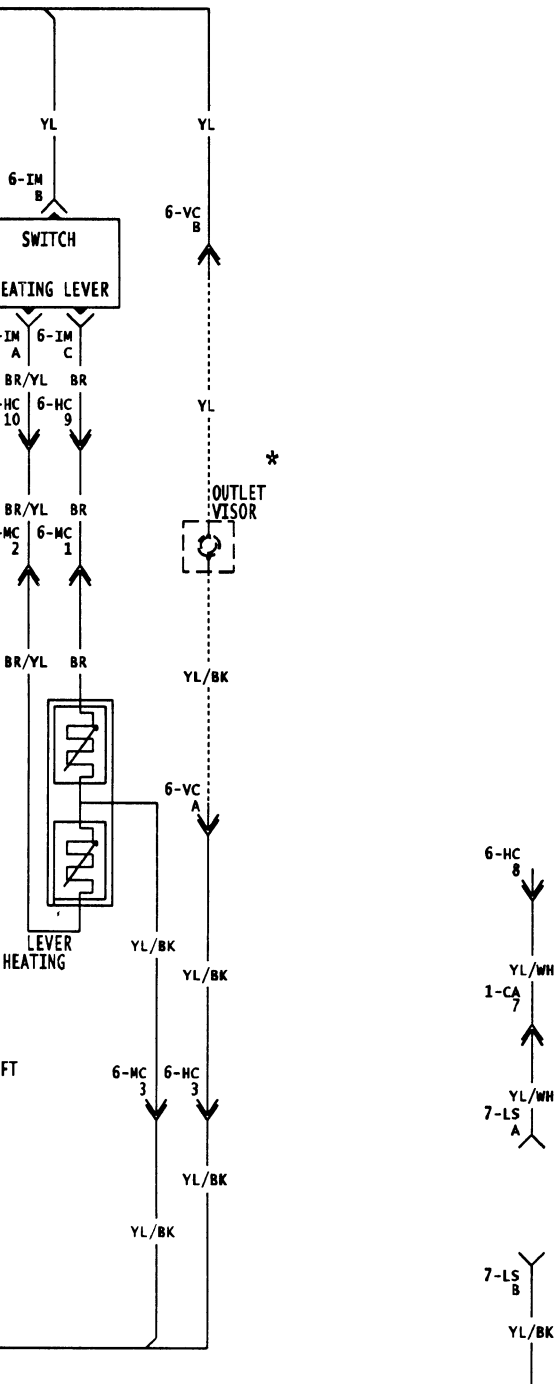

2002 SUMMIT 600/700/800

2002 SUMMIT 600/700/800

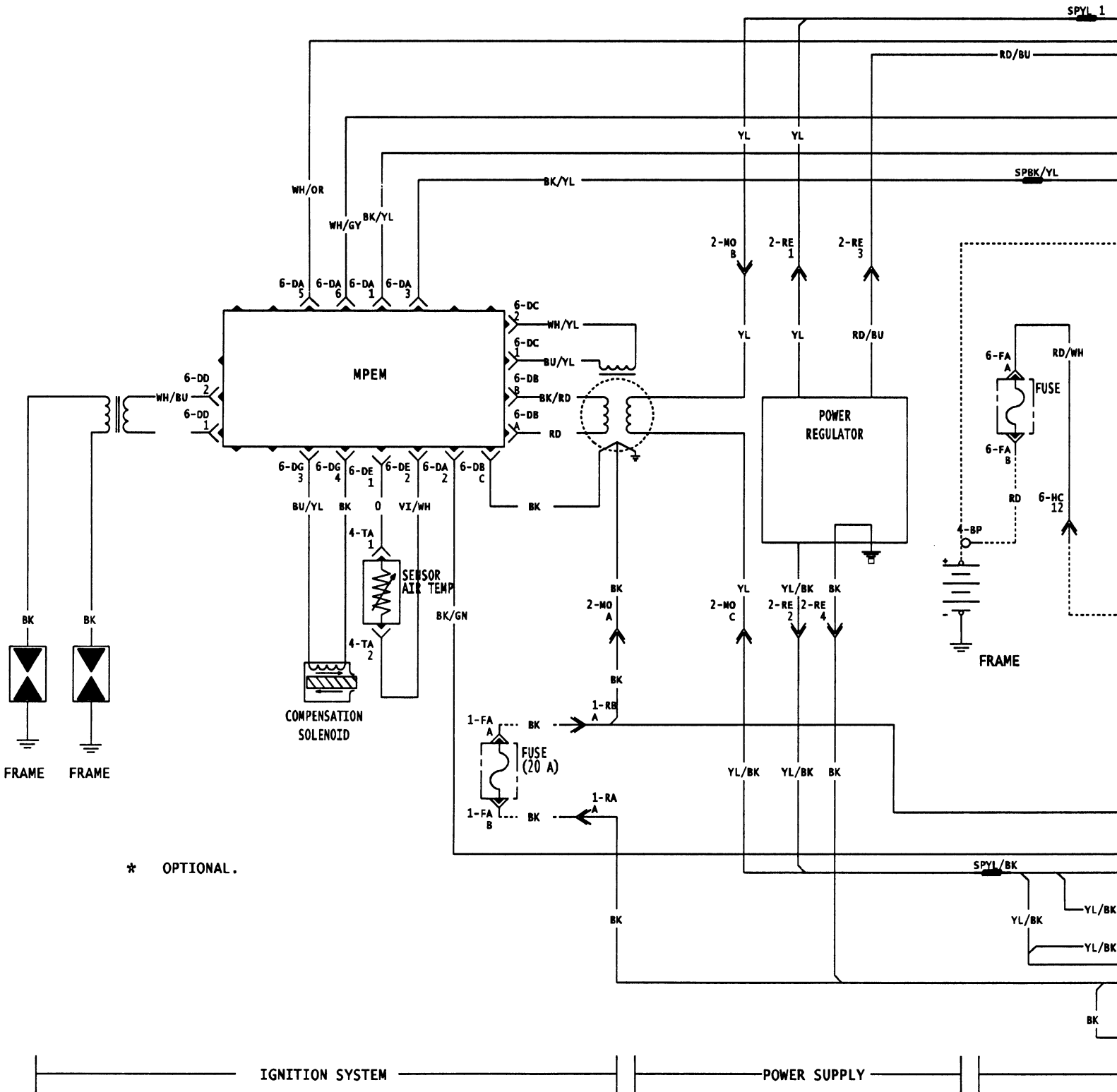

* OPTIONAL.

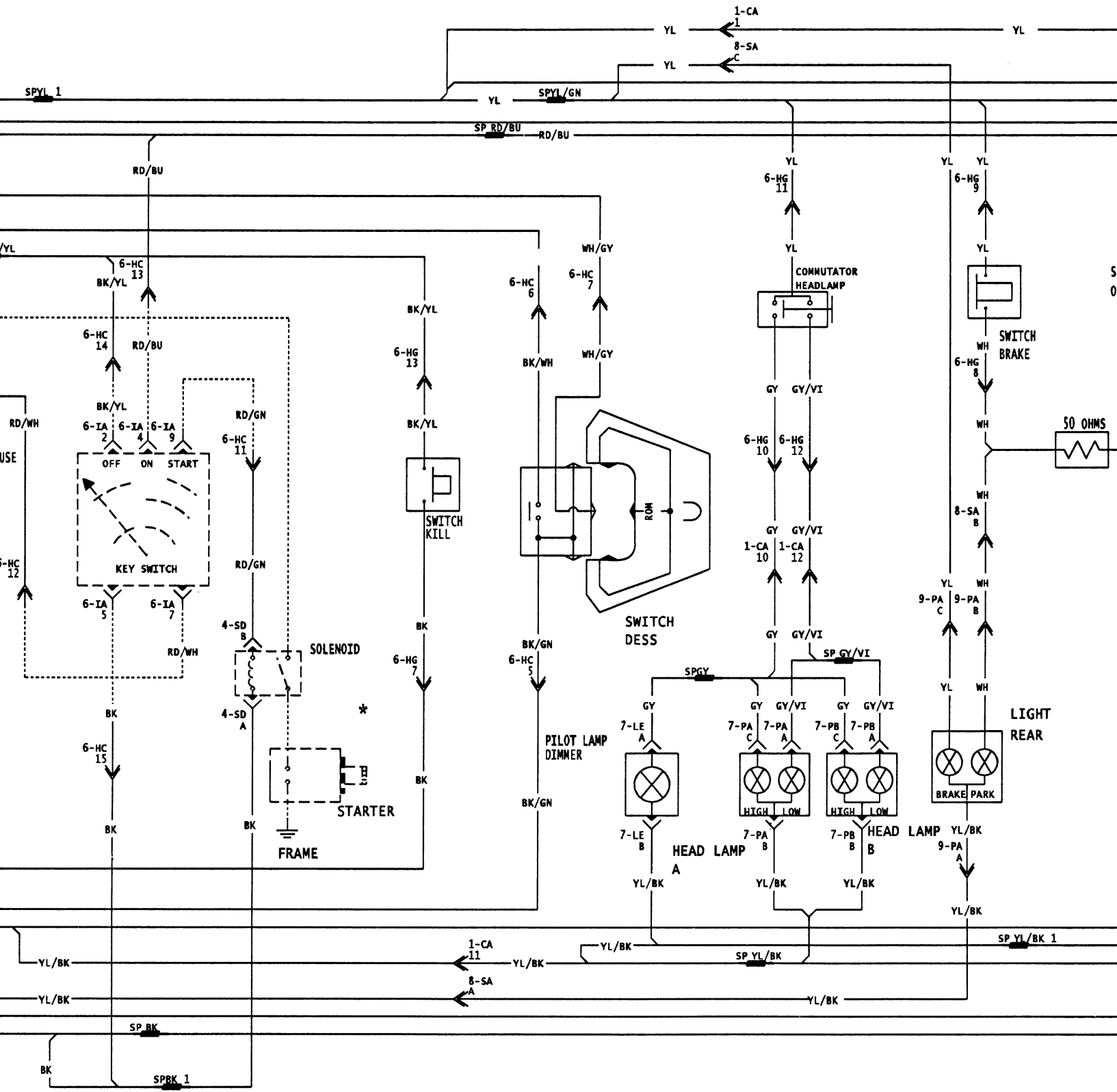

STARTER AND IGNITION SWITCHES

LIGHTING

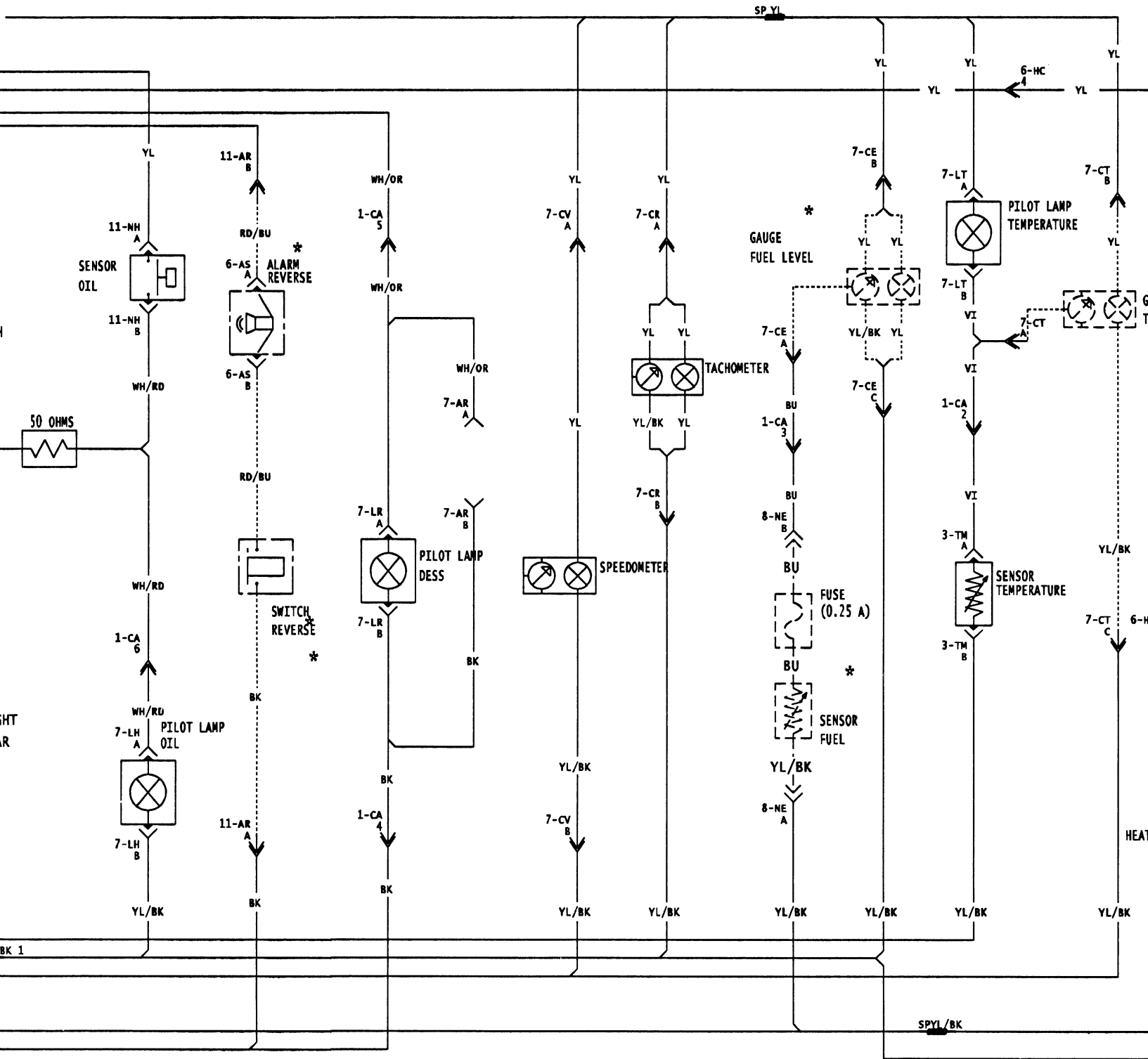

INSTRUMENTS

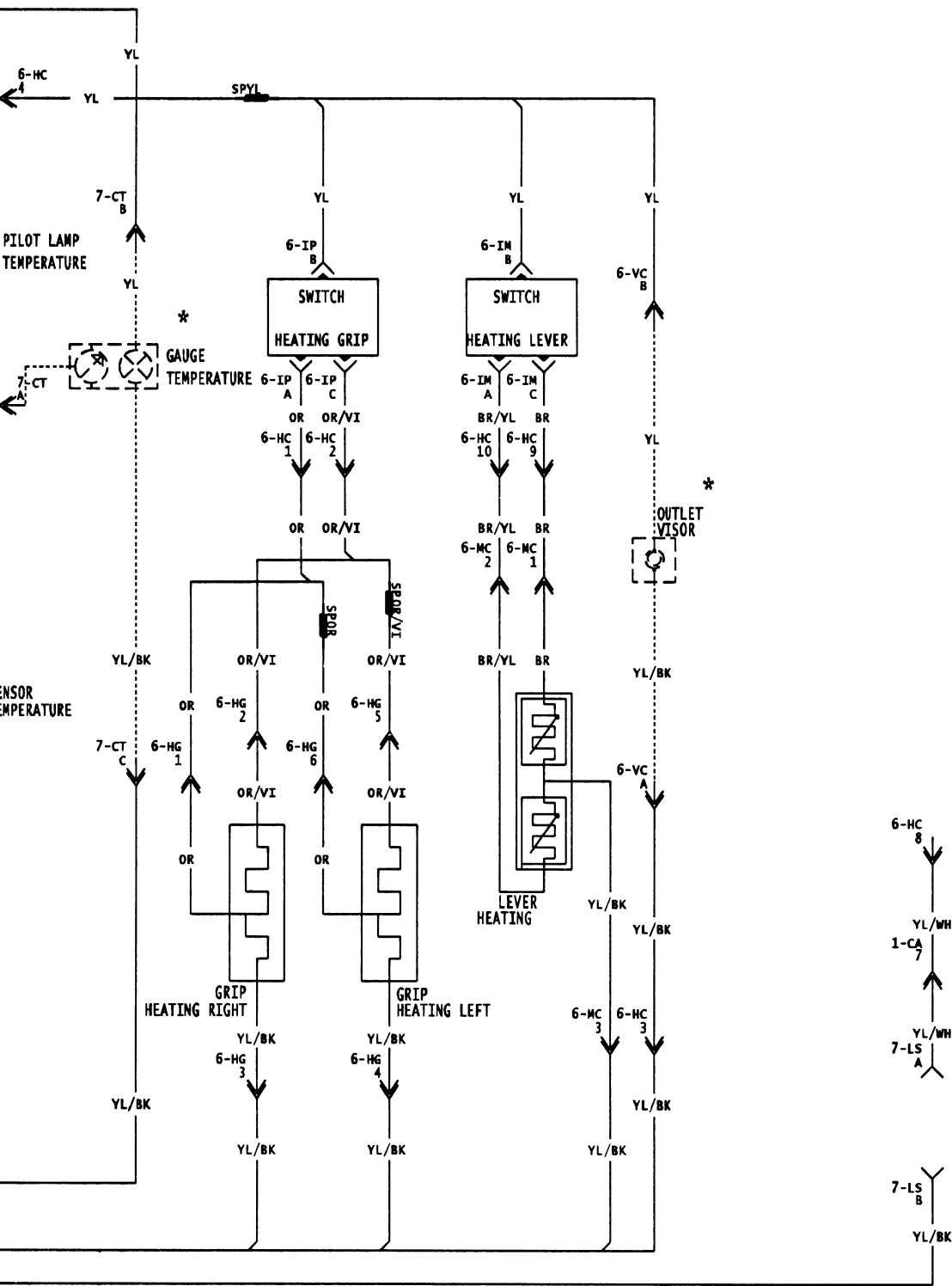

HEATING ELEMENTS

SUSPENSION OUTLET

2002 SUMMIT 600/700/800 RER

2002 SUMMIT 600/700/800 RER

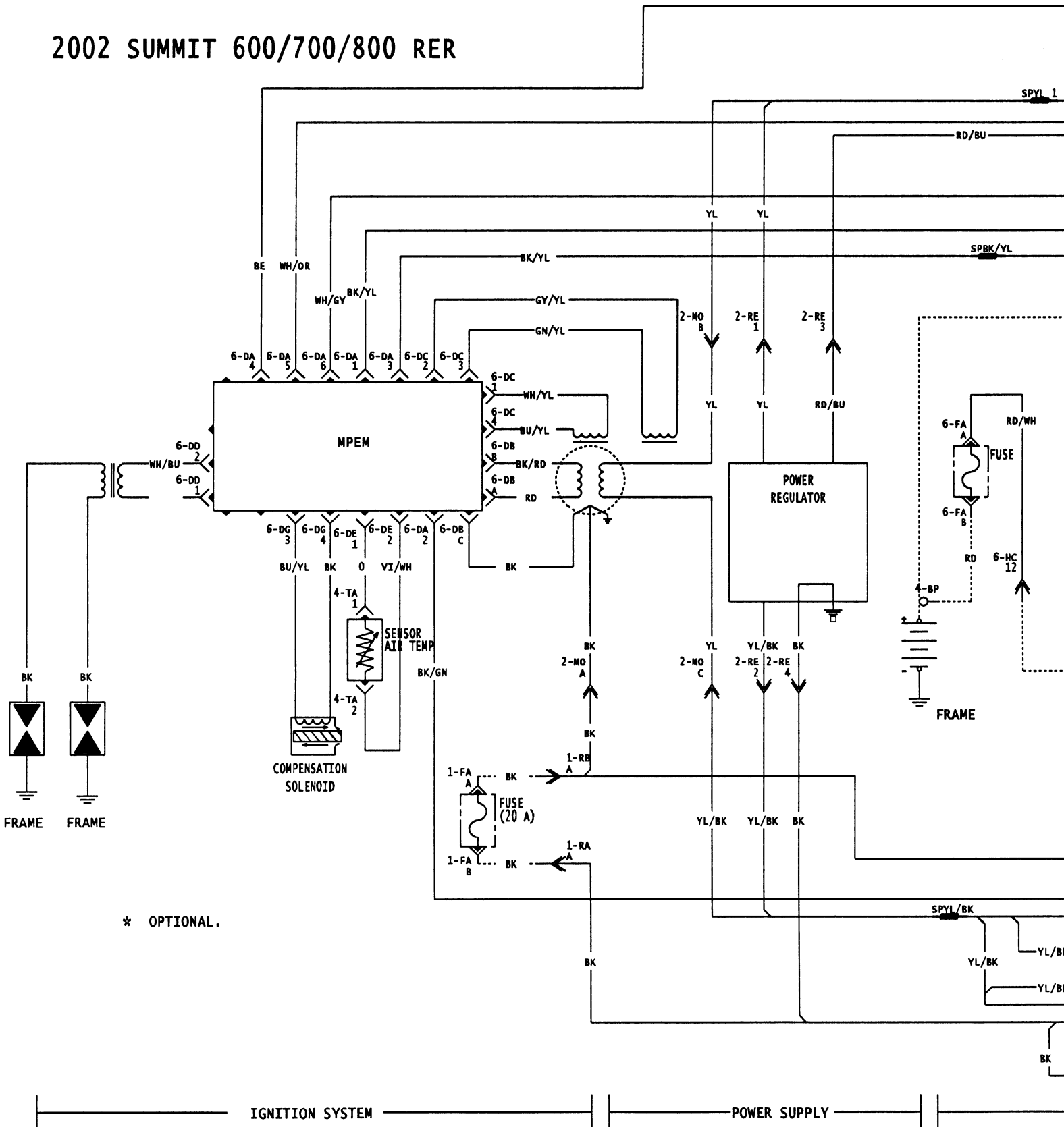

* OPTIONAL.

IGNITION SYSTEM

POWER SUPPLY

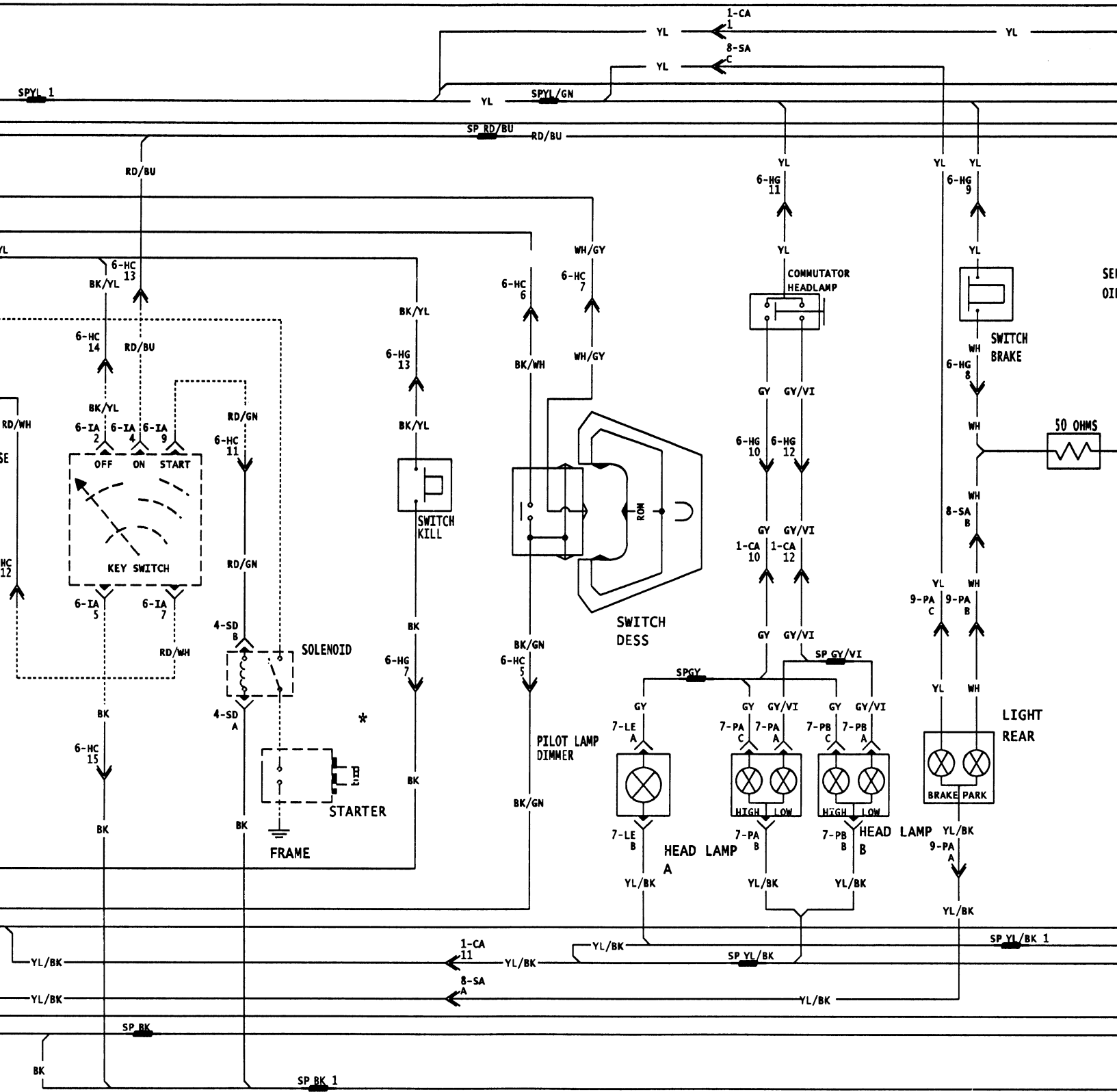

STARTER AND IGNITION SWITCHES

LIGHTING

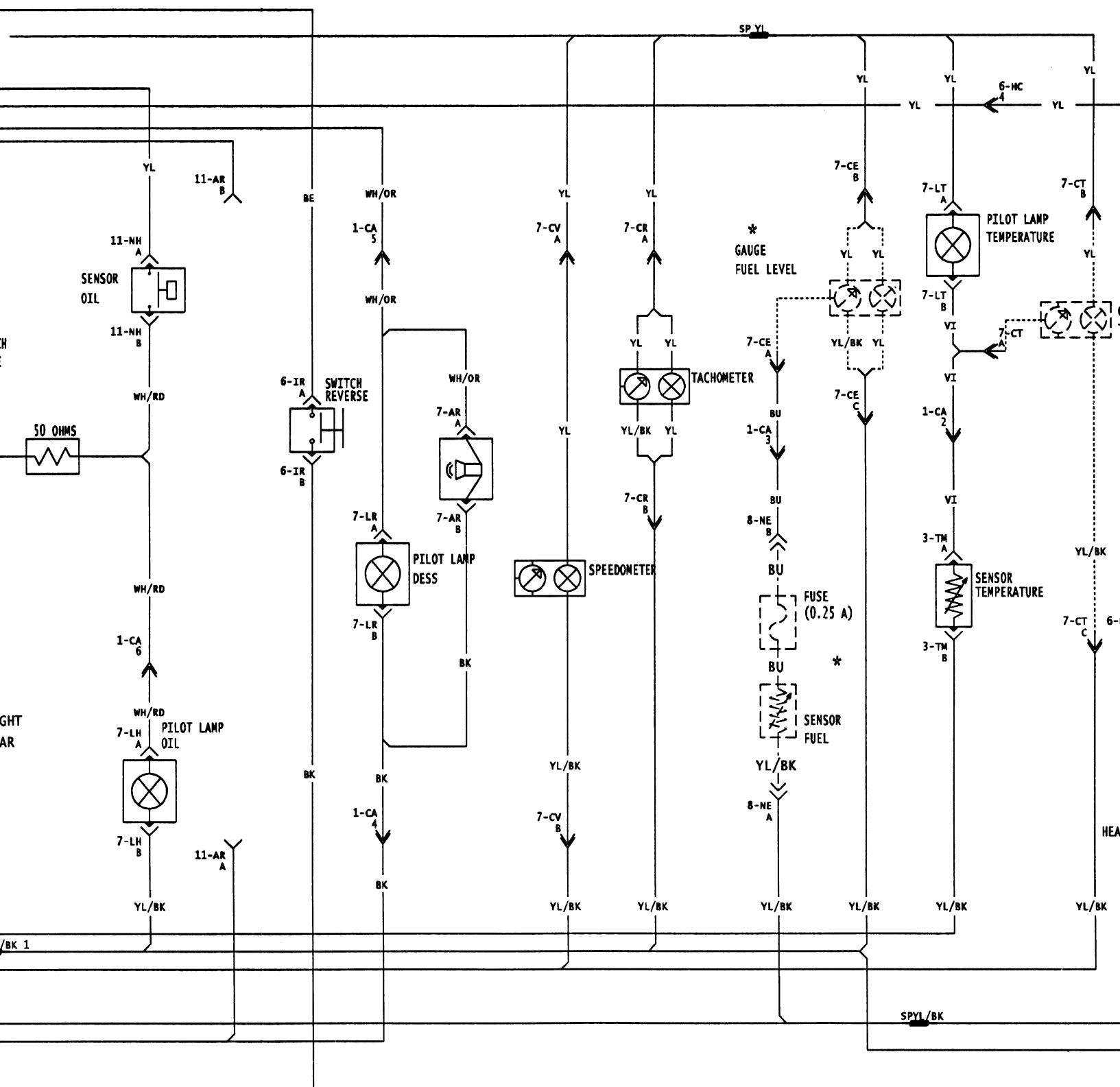

INSTRUMENTS

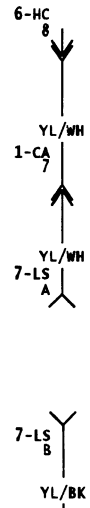
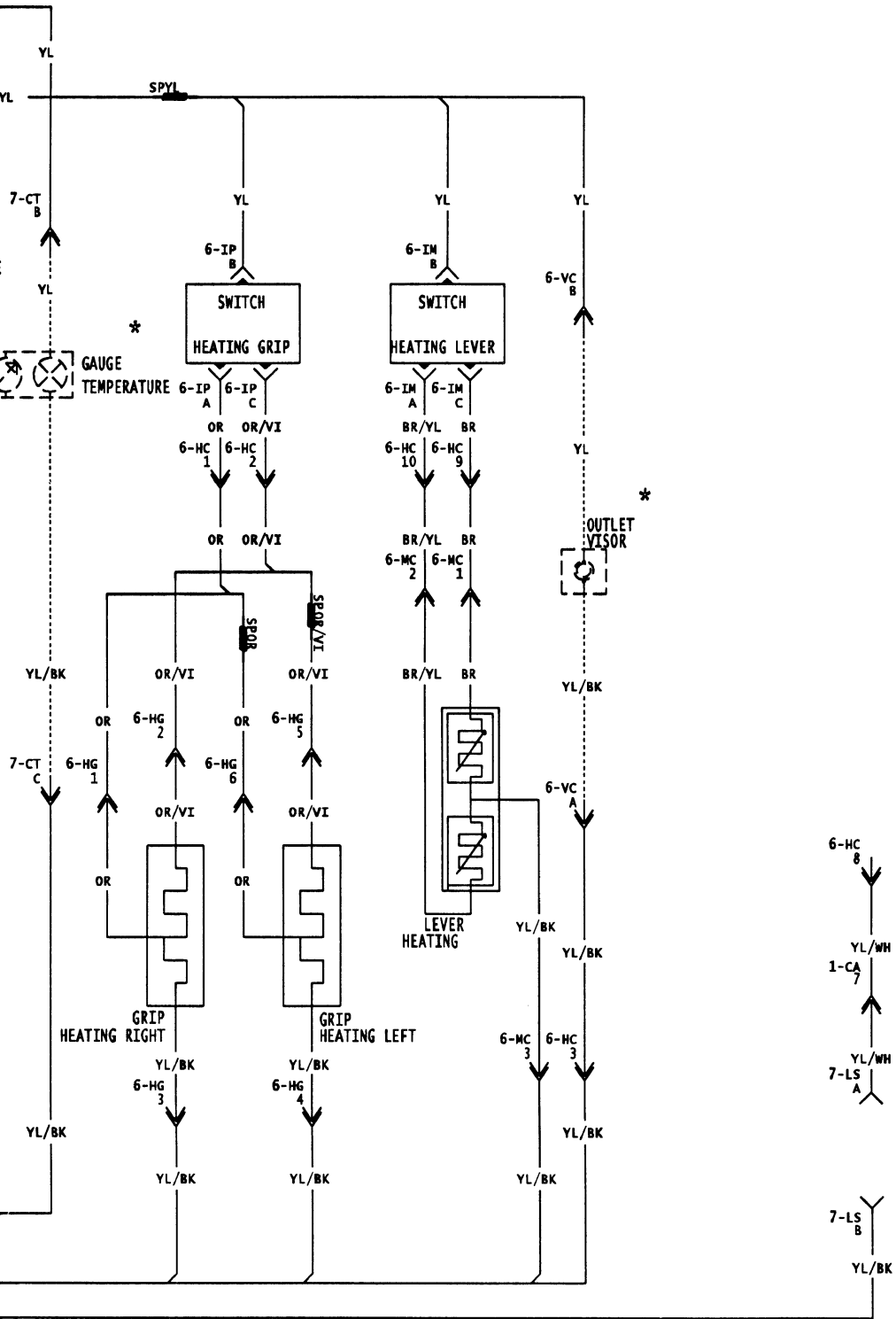

HEATING ELEMENTS

SUSPENSION OUTLET

ski-doo[®]

2002



®™ Trademarks of Bombardier Inc. or its subsidiaries.
© 2002 Bombardier Inc. All rights reserved.
Printed in Canada.

