TABLE OF CONTENTS

BODY	09-02-1
INSTALLATION AND ADJUSTMENT	09-02-1
HEADLAMP BEAM AIMING.....	09-02-1
BULB REPLACEMENT	09-02-1
DECAL	09-02-2
WINDSHIELD INSTALLATION	09-02-2
GUARD	09-02-2
WIRING HARNESS	09-02-2
CABLES	09-02-2
PIPING	09-02-2
PLASTIC MAINTENANCE AND REPAIR	09-02-3
MAINTENANCE	09-02-3
REPAIR.....	09-02-4
MATERIAL HANDLING.....	09-02-5
REPAIR PROCEDURE FOR R.R.I.M. POLYURETHANE	09-02-5
FRAME	09-03-1
FRAME CLEANING	09-03-1
FRAME WELDING	09-03-1
FRAME COMPONENT REPLACEMENT	09-03-1

BODY

INSTALLATION AND ADJUSTMENT

HEADLAMP BEAM AIMING

Beam aiming is correct when center of high beam is 25 mm (1 in) below the headlamp horizontal center line, scribed on a test surface, 381 cm (12 ft 6 in) away.

Measure headlamp center distance from ground. Scribe a line at this height on test surface (wall or screen). Light beam center should be 25 mm (1 in) below scribed line.

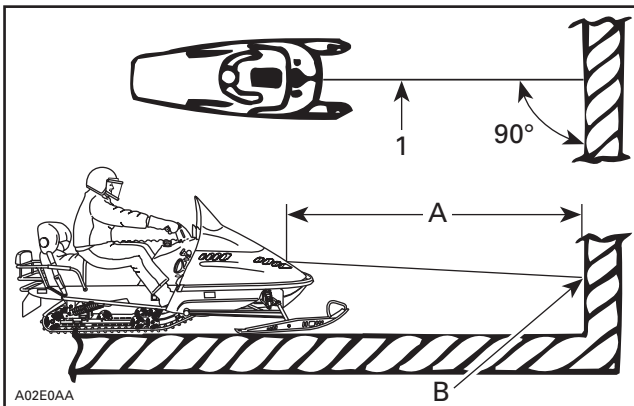

TYPICAL

1. Headlamp center line
- A. 381 cm (12 ft 6 in)
- B. 25 mm (1 in) below center line

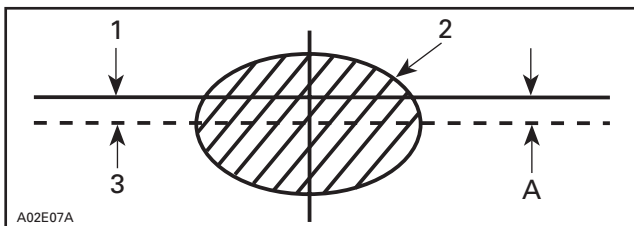

1. Headlamp horizontal
2. Light beam (high beam) (projected on the wall)
3. Light beam center
- A. 25 mm (1 in)

Required Conditions

Place the vehicle on a flat surface perpendicular to test surface (wall or screen) and 381 cm (12 ft 6 in) away from it.

Rider or equivalent weight must be on the vehicle.

Select **high beam**.

BULB REPLACEMENT

Headlamp

If any headlight bulb is burnt, remove windshield. Unplug burnt bulb connector. Remove the rubber boot.

Unfasten bulb retainer ring. Detach the bulb and replace. Properly reinstall parts.

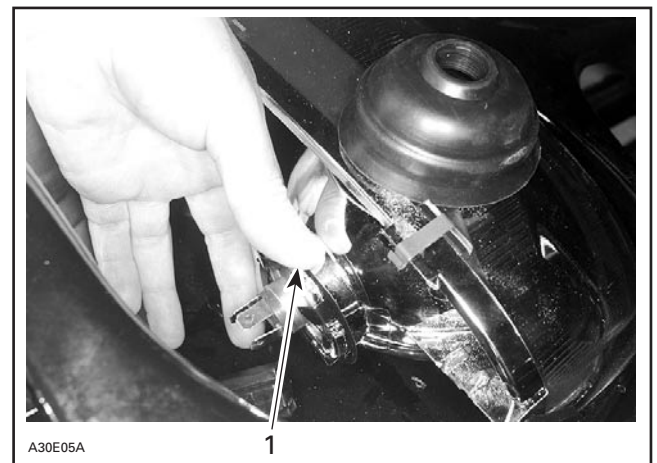

1. Locking ring

CAUTION: Never touch glass portion of an halogen bulb with bare fingers, as it shortens its operating life. If by mistake glass is touched, clean it with isopropyl alcohol which will not leave a film on the bulb.

Taillight

If the taillight bulb is burnt, expose the bulb by removing red plastic lens. To remove, unscrew the 2 retaining screws. Verify all lights after replacement.

Section 09 BODY/FRAME

Subsection 02 (BODY)

DECAL

To remove a decal; heat old decal with a heat gun and peel off slowly.

Using isopropyl alcohol, clean the surface and dry thoroughly.

Apply liquid soap to new decal and carefully position the decal. Using a sponge or a squeegee, remove the air bubbles and surplus water working from the center toward the edges. Allow to air dry.

CAUTION: Do not apply isopropyl alcohol or solvent directly on decals. Use only in a well ventilated area.

WINDSHIELD INSTALLATION

Remove protective film.

Position the windshield on the hood then push it down until the tabs are fully inserted into the hood slots. Lock the windshield tabs in position.

GUARD

Disassembly and Assembly

NOTE: For additional information (ex.: exploded view) refer to the correspondent *Parts Catalog*.

WARNING

Engine should be running only with guard well secured in place.

Inspection

Check guard mounting bosses, clips and retainers for wear.

WIRING HARNESS

WARNING

Ensure all terminals are properly crimped on the wires and that all connector housings are properly fastened. Keep wires away from any rotating, moving, heating and vibrating parts. Use proper fastening devices as required.

CABLES

WARNING

Before installation, ensure that all cables are in perfect condition. Properly install the cable ends and secure them in place. Pay attention to route them properly, away from any rotating, moving, heating or vibrating parts.

PIPING

WARNING

Always ensure that the fuel, vent, primer, impulse, injection oil and rotary valve oil lines are properly fixed to their connectors, that they are not perforated or kinked and that they are properly routed away from any rotating, moving, heating or vibrating parts. Also check for leaks. Replace if required.

NOTE: Refer to proper *Parts Catalog* to find suitable clip part numbers.

PLASTIC MAINTENANCE AND REPAIR

MAINTENANCE

Clean the vehicle thoroughly, removing all dirt and grease accumulation.

To clean use a soft clean cloth and either soapy water or isopropyl alcohol.

To remove grease, oil or glue use isopropyl alcohol.

CAUTION: Do not apply isopropyl alcohol or acetone directly on decals.

CAUTION: The following products must not be used to clean or wax any of the plastic components used on the vehicles:

- gasoline
- brake fluid
- kerosene
- diesel fuel
- lighter fluid
- varsol
- naphtha
- acetone
- strong detergents
- abrasive cleaners
- waxes containing an abrasive or a cleaning agent in their formula.

Apply wax on glossy finish only. Protect the vehicle with a cover to prevent dust accumulation during storage.

CAUTION: If for some reason the snowmobile has to be stored outside it is preferable to cover it with an opaque tarpaulin. This will prevent the sun rays from affecting the plastic components and the vehicle finish.

Section 09 BODY/FRAME

Subsection 02 (BODY)

REPAIR

The very first step before repairing plastic materials is to find out exactly which type of material is involved. Refer to following chart.

CAUTION: Consult chart and repair kit instructions carefully, some repair products are not compatible with certain plastics.

WARNING

Polycarbonate windshields must never be repaired by welding or otherwise.

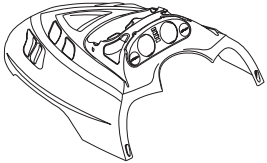
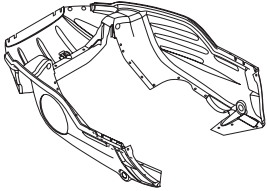
PART	MODEL	REPAIRABLE		
		IMPACT COPOLYMER	R.R.I.M. POLYURETHANE	SURLYN
HOOD  <small>A32H334</small>	ZX LIQUID and ZX FAN (blue color)			
	ZX FAN (deep black, yellow)			
BOTTOM PAN  <small>A32H344</small>	ALL ZX SERIES			

MATERIAL HANDLING

R.R.I.M. Polyurethane

R.R.I.M. polyurethane is light colored (tan) on the inside with a smooth surface.

WARNING

Material should be repaired and repainted in a well-ventilated area only.

CAUTION: Clean R.R.I.M. with isopropyl alcohol or Crest Hi-Solv product. **Never** use cleaners or products that contain **chlorine**.

CAUTION: R.R.I.M. should never be exposed to temperatures exceeding 93°C (200°F).

NOTE: When working on a R.R.I.M. surface, never use a grinder or a high revolution tool such as an air or electric buffer. Use of such tools could overheat material and liberate agents in it thus causing a bad adhesion.

Surlyn

Surlyn is a thermoplastic material with high gloss finish. Surlyn is weatherable, durable and provides improved scratch and abrasion resistance. Surlyn is a modified ionomer resin which is molded in color to give surface finish directly from mold.

CAUTION: Surlyn should never be exposed to temperatures exceeding 80°C (175°F).

NOTE: Several common cleaners and waxes do not cause noticeable appearance defects to Surlyn.

NOTE: Surlyn surface is paintable.

CAUTION: Do not sand the Surlyn surface or use any abrasive product and rubbing compound.

REPAIR PROCEDURE FOR R.R.I.M. POLYURETHANE

Small Scratches

- Sand and scuff area.
- Feather out edges.
- Paint with a matching acrylic auto touch-up paint.

Deep Scratches

- Sand and scuff area.
- Make a V groove using a knife or a rough round file.
- Clean surface with isopropyl alcohol or Crest Hi-Solv stock no. AH-S product.
- Cover with TP-E epoxy mixed in equal quantities.
- Heat the surface with a heater lamp placed at 38 cm (15 in) for a period of 15 minutes.
- Sand the surface using a smooth dry sand paper.
- Use the same product if a final finish is required.
- Clean surface with Crest Hi-Solv product.
- Apply a flexible primer such as Crest Prima Flex stock no. AP-F.
- Wait 10 minutes.
- Repaint (air dry during 72 hours (approximately)).

Large Crack

- Sand and scuff outside and inside area by exceeding it 31.7 mm (1-1/4 in) on each side and 12.7 mm (1/2 in) at each end.
- Make a V groove (appr. 90°) on both sides of hood using a knife or a rough round file.
- Enlarge the crack to 2.4 mm (3/32 in) – 3.2 mm (1/8 in) using a sharp knife.
- Clean outside and inside surface with isopropyl alcohol or Crest Hi-Solv product.
- Repair inside surface first.
- Cover inside area with Crest TP-E epoxy.
- Apply a 50 mm x 30 mm (2 in x 1-1/4 in) patch. If no room for the patch, use tape.
- Cover exterior surface with same product. Damaged area should be slightly higher.
- Heat surface with a heater lamp placed at 38 mm (15 in) for a period of 15 minutes.
- Sand outside surface using a smooth dry sand paper.
- Use same product if a final finish is required.
- Apply a flexible primer.
- Wait 10 minutes.
- Repaint (air dry during 72 hours approximately).

NOTE: Both R.R.I.M. materials are high static plastics, painting must be done in a dust free area such as a paint booth.

Section 09 BODY/FRAME

Subsection 02 (BODY)

Crest products used in R.R.I.M. repair procedure are available from following locations:

CREST MAIN OFFICE AND MANUFACTURING PLANT	
CREST INDUSTRIES, INC. 3841 13 th Street Wyandotte, Michigan 48192	Phone: 734-283-4100 Toll Free: 1-800-822-4100 Fax: 1-800-344-4461 Fax: 734-283-4461 E-Mail: info@crestauto.com www.crestauto.com

DISTRIBUTOR WAREHOUSE LOCATIONS		
UNITED STATES		CANADA
CREST EAST COAST, INC. P.O. Box 550 1109 Industrial Parkway Brick, New Jersey 08723 Phone: 732-458-9000 Fax: 732-458-5753	CREST INDUSTRIES, INC. (CREST MID-WEST) 231 Larkin Williams Ind. Court St. Louis, Missouri 63026 Phone: 314-349-4800 Toll Free: 1-800-733-2737 Fax: 314-349-4888 Toll Free Fax: 1-800-776-2737	J2 PRODUCTS A Division of Sawill Ltd. 54 Audia Court, Unit 2A Concord, Ontario, L4K 3N4 <i>Phone:</i> Toronto: 416-665-1404 Concord: 905-669-9410 <i>Fax:</i> Concord: 905-669-9419
CREST PRODUCTS, INC. <i>Shipping Address:</i> 125 Production Drive Yorktown, Virginia 23693 Phone: 757-599-6572 Virginia: 1-800-572-5025 Outstate: 1-800-368-5033 Fax: 757-599-6630 <i>Mailing Address:</i> P.O. Box 2018 Grafton, Virginia 23692	CREST MID WEST Regional Branch Warehouses CREST INDUSTRIES, INC. P.O. Box 635 Mountain Home, Arkansas 72653 Phone: 501-491-5583 Toll Free: 1-800-733-2737	WHEEL-IN AUTOMOTIVE SUPPLY <i>Shipping Address:</i> No. 1, 3911A Brandon St. S.E. Calgary, Alberta, T2G 4A7 Phone: 403-287-0775 <i>Mailing Address:</i> P.O. Box 40036 929-42 nd Avenue S.E. Calgary, Alberta, T2G 5G5
CREST INDUSTRIES SOUTHEAST, INC. <i>Shipping Address:</i> 1400-B Woodstock Rd. Roswell, Georgia 30075 <i>Mailing Address:</i> 11530 Bowen Road Roswell, Georgia 30075 Phone: 770-642-7670 Toll Free: 1-800-552-0876 Fax: 770-642-7679	CREST INDUSTRIES, INC. 4200 Jackson Street, Unit 9 Denver, Colorado 80216 Phone: 303-320-3900 Toll Free: 1-800-733-2737 Fax: 303-320-6509 REM-CO DISTRIBUTING, INC. 5625 S. Adams Tacoma, Washington 98409 Phone: 253-474-5414 Toll Free: 1-800-735-7224 Fax: 253-474-7339	

FRAME

FRAME CLEANING

NOTE: For bare aluminum frames use only aluminum cleaner and follow instructions on container. (Dursol cleaner or equivalent).

Clean frame and tunnel with appropriate cleaners and rinse with high pressure hose.

Touch up all metal spots where paint has been scratched off. Spray all bare metal parts of vehicle with metal protector.

Seat Cleaning

For all models, it is recommend to clean the seat with a solution of **warm soapy water**, using a soft clean cloth.

CAUTION: Avoid use of harsh detergents such as strong soaps, degreasing solvents, abrasive cleaners, paint thinners, etc. that may cause damage to the seat cover.

FRAME WELDING

Aluminum Frame

- No welds should be done on a aluminum frame except required; mentioned on a Bombardier service bulletin.
- Use ER-5356 rods for MIG or TIG welding.

CAUTION: Before performing electrical welding anywhere on the vehicle, unplug MPEM. On models equipped with a battery, also unplug the negative cable. This will protect the electronic box and battery against damage caused by flowing current when welding.



TYPICAL — MPEM UNPLUGGED

CAUTION: If welding is to be done near plastic material, it is recommended to either remove the part from the area or to protect it with aluminum foil to prevent damage.

FRAME COMPONENT REPLACEMENT

Drilling Procedure

When drilling self-piercing rivets, use Supertanium™ drill bit (P/N 529 031 800), available in a 5 mm (3/16 in) size and shipped in packs of 2.

For proper drilling instructions and to prevent premature wear, follow the procedure below.

Always use a variable speed electric drill.

Partially drill rivet end — not the rivet head.

Maintain a slow to medium speed at all times when drilling. The proper speed is attained when a constant chip is ejected.

NOTE: To increase bit life, use Bombardier synthetic chaincase oil (P/N 413 803 300) as a cutting oil.

CAUTION: High speed drilling will cause excessive heat which may destroy the cutting edge of the bit, therefore avoid using pneumatic drills.



Cut rivet using a chisel.

Remove part riveted.

Drive out remaining rivet head using a punch.