

# TABLE OF CONTENTS

---

<b>STEERING SYSTEM</b> .....	<b>08-02-1</b>
DISASSEMBLY AND ASSEMBLY .....	08-02-2
INSPECTION .....	08-02-8
HANDLEBAR ADJUSTMENT .....	08-02-8
STEERING ADJUSTMENT (SKIS) .....	08-02-9
LUBRICATION .....	08-02-12

---

<b>SUSPENSION AND SKI SYSTEM</b> .....	<b>08-03-1</b>
DISASSEMBLY .....	08-03-2
INSPECTION .....	08-03-3
INSTALLATION .....	08-03-3

# STEERING SYSTEM

*CK3 Series*

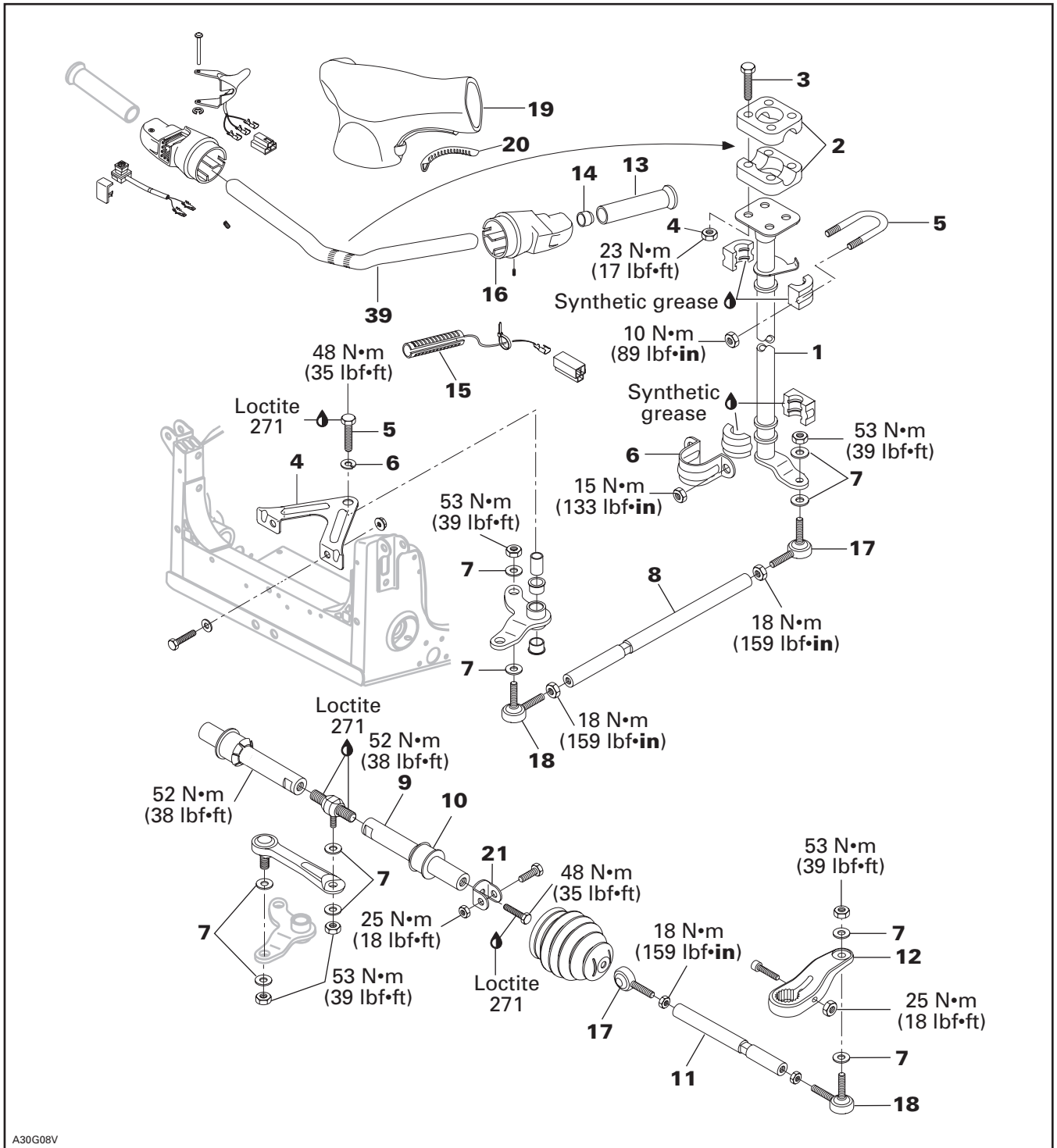

A30G08V

TYPICAL

## Section 08 STEERING/FRONT SUSPENSION

### Subsection 02 (STEERING SYSTEM)

#### **WARNING**

On Mach Z TECH PLUS do not lift vehicle by steering column.

## DISASSEMBLY AND ASSEMBLY

### 13, Grip

Grips must be carefully removed to prevent damaging the heating elements.

Heat grip with a heat gun.

Apply tape to handlebar near the grip to protect paint.

Inject compressed air into the handlebar and twist grip as pulling it out.

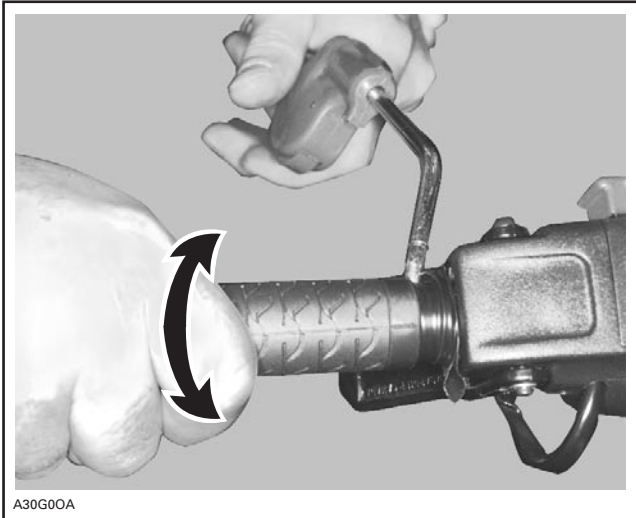

The grips might be unremovable as explained above, in this case, carefully proceed as follows to prevent damaging the heating elements.

Locate the element wires inside the handlebar; look through end of grip. Start cutting the grip exactly opposite the element wires and immediately peel it open to locate the gap in the heating element, as shown.

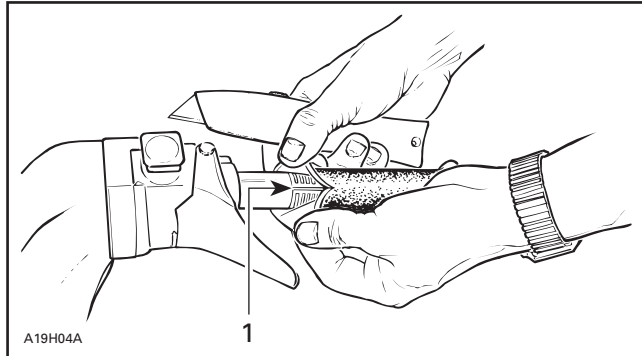

#### **TYPICAL**

1. Gap in the heating element opposite the wires

Continue cutting along the gap and remove the grip.

If required, slowly peel heating element no. 15 from handlebar and remove it.

To install, stick the heating element to the handlebar making sure the wires do not interfere with operation of the accelerator or brake handle.

Prior to install grips, position heating element protector no. 14.

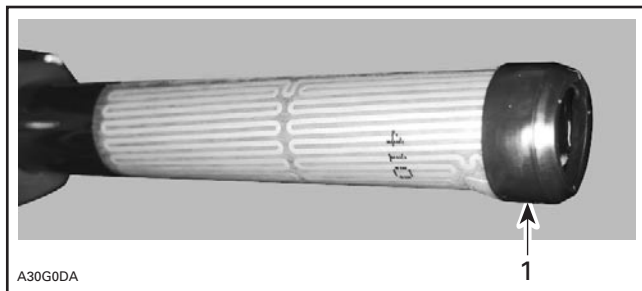

1. Heating element protector

#### **WARNING**

Never use lubricants (e.g. oil, grease, soap etc.) to install the handlebar grip.

## Section 08 STEERING/FRONT SUSPENSION

### Subsection 02 (STEERING SYSTEM)

Heat the grip with a heater gun or a spot light to ease installation. Insert new grip with compressed air.



### Tilt Handlebar Mechanism

#### **Mach Z TECH PLUS**

Move handlebar to its higher position.

Remove Allen screw retaining locking lever. Pull out locking lever.

Remove steering pad. Unhook throttle cable from throttle lever.

Unscrew all 4 nuts and bolts securing handlebar.

**NOTE:** Do not unbolt master cylinder needlessly. Move handlebar apart, keeping master cylinder reservoir in upward position.

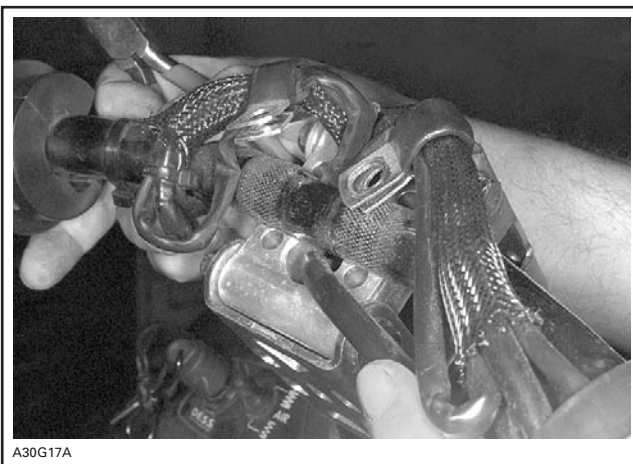

**HANDLEBAR READY TO BE MOVED**

Unbolt 4 nuts and bolts retaining clamp, front and rear arms.

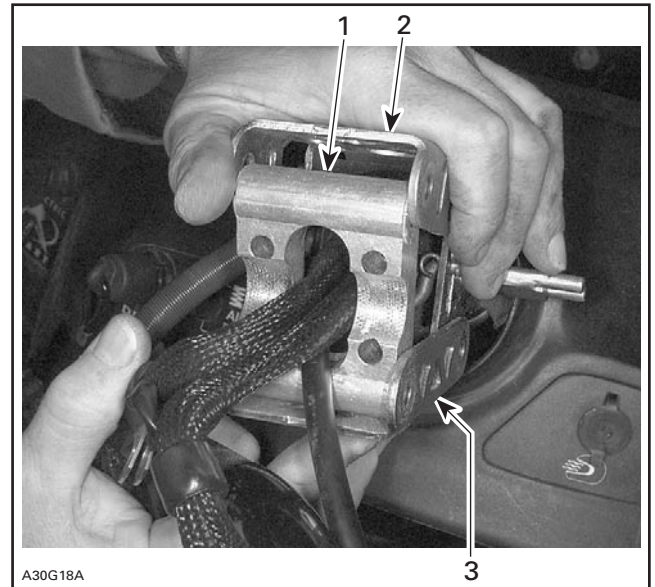

1. Clamp
2. Front arm
3. Rear arm

Remove plate, circlip on left side then, plastic washer on right side.

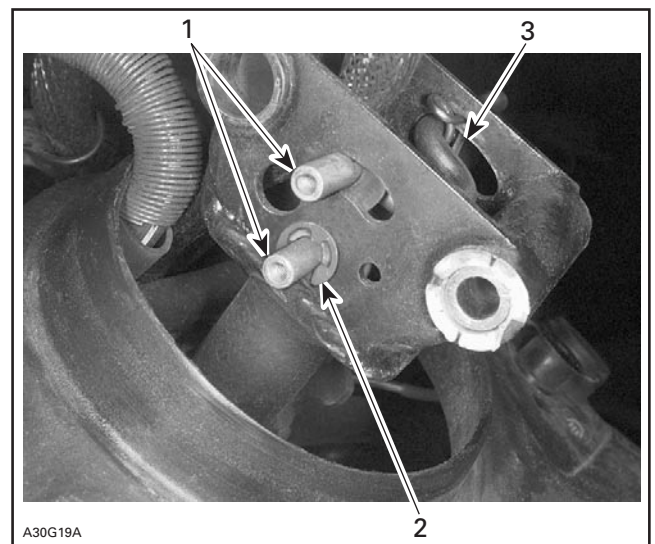

1. Plate removed
2. Circlip to be removed
3. Plastic washer on right side

## Section 08 STEERING/FRONT SUSPENSION

### Subsection 02 (STEERING SYSTEM)

Using a hook, pull spring right side end to allow removing welded lock.

#### WARNING

Spring will be ejected upon welded lock removal.



#### WELDED LOCK REMOVAL

To reassemble tilt handlebar mechanism, reverse disassembly procedure. However, pay attention to the following:

Install spring with its locking tab facing bottom and rear.

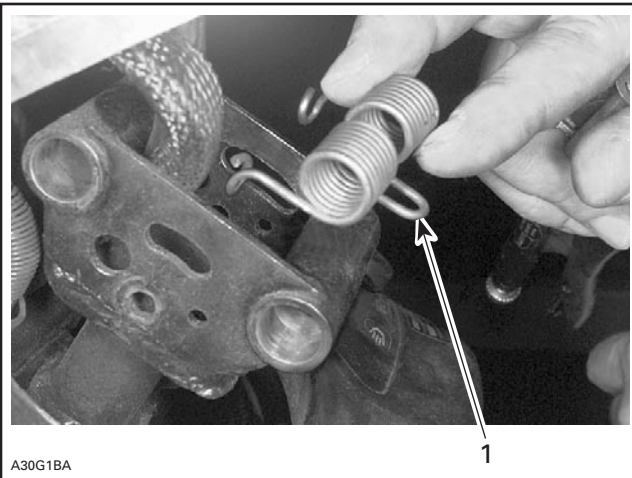

#### 1. Spring tab

Hold left side portion of spring with a punch inserted in lower bracket. Pull right side spring end with a hook during welded lock insertion.

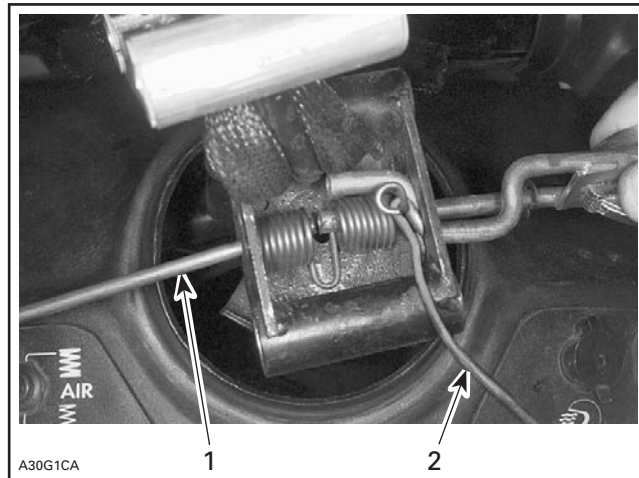

1. Punch
2. Hook to pull spring end

Proceed the same with left side spring end.

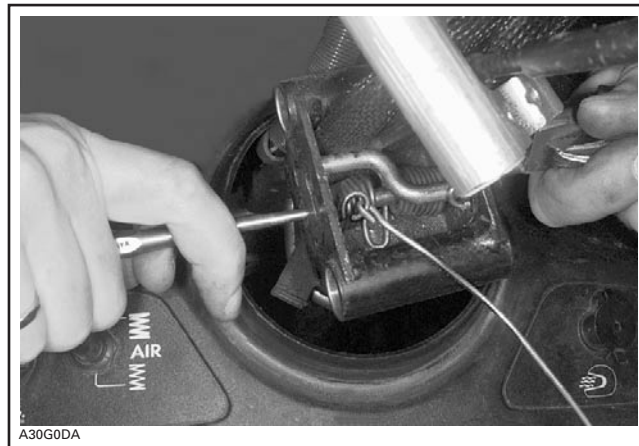

Temporary install locking lever. Push it forward in order to maintain locking rod fully engaged. Tighten screws retaining plate while keeping locking rod fully engaged.

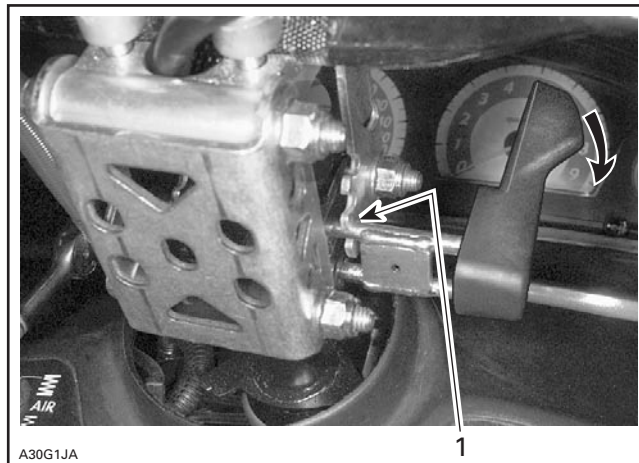

1. Locking rod fully engaged

## Section 08 STEERING/FRONT SUSPENSION

### Subsection 02 (STEERING SYSTEM)

Install a new plastic washer on each end of spring.

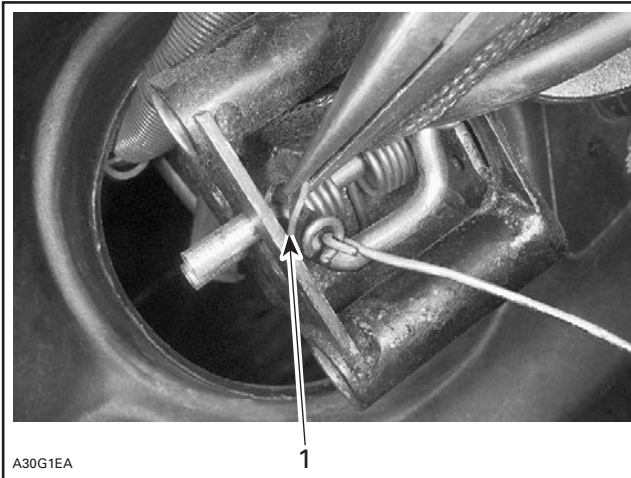

1. Plastic washers

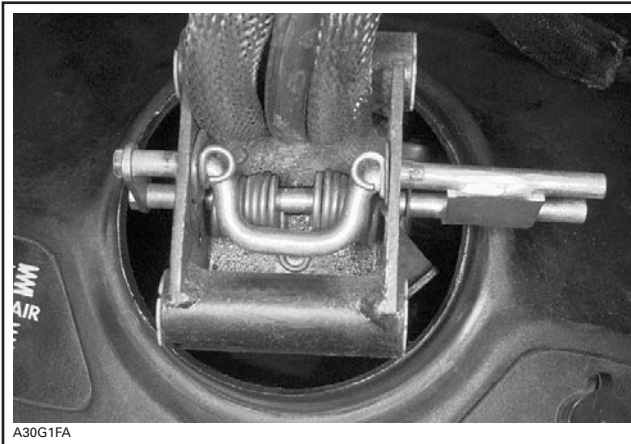

**WELDED LOCK INSTALLED**

Throttle cable must be under handlebar and wiring harnesses above.

All 4 nuts retaining front and rear arms must be on right side.

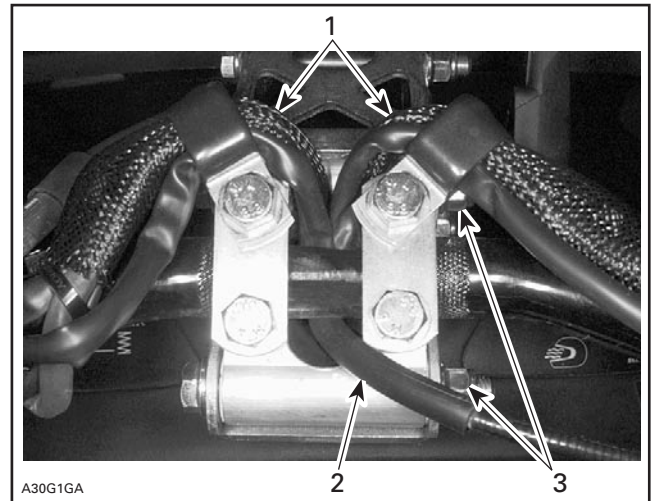

1. Wiring harnesses  
2. Throttle cable  
3. Nuts on right side

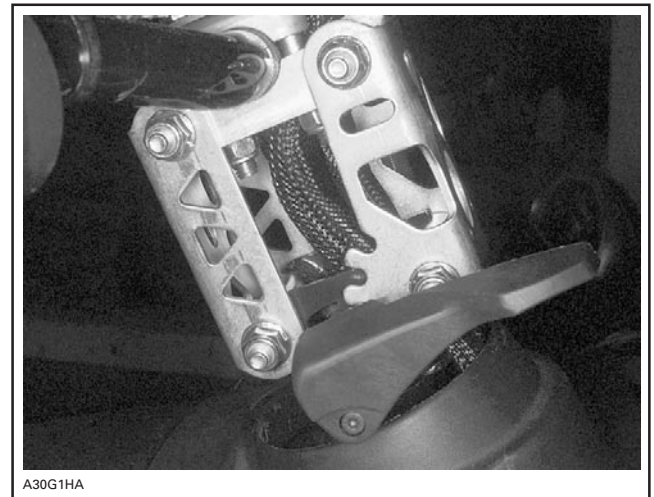

**HANDLEBAR IN UPPER POSITION**



**HANDLEBAR IN LOWER POSITION**

## Section 08 STEERING/FRONT SUSPENSION

### Subsection 02 (STEERING SYSTEM)

#### 1, Steering Column

Remove steering pad, remove master cylinder from handlebar and put it aside. Remove circlip retaining throttle cable to throttle housing. Unplug all connector housings of handlebar switches. Remove handlebar assembly.



HANDLEBAR ASSEMBLY

Cut locking tie retaining brake line and throttle cable to steering column.

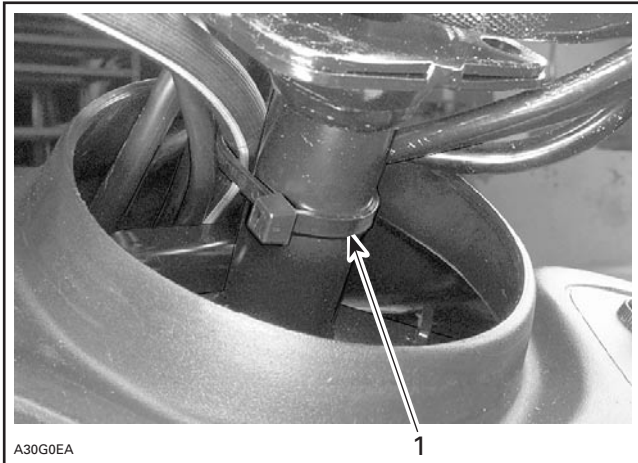

1. Cut this locking tie

Remove the air intake silencer then center and magneto side carburetors.

Unbolt console at center and sides.

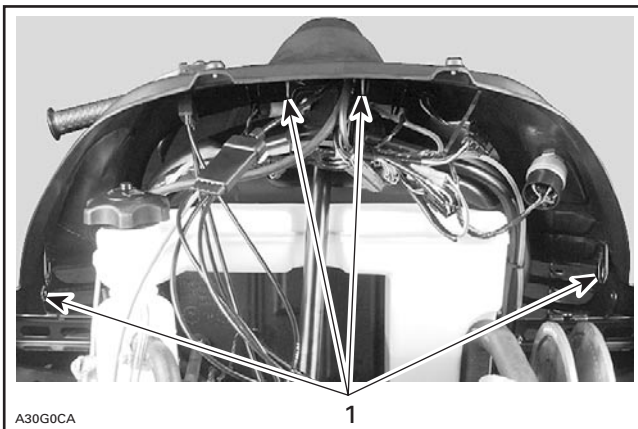

1. Unbolt console

Detach the short tie rod (under the engine) from the steering column. Note that a hardened flat washer no. 7 goes on each side of steering column lever. Unfasten steering column from vehicle.

#### 12, Steering Arm

To maintain correct steering geometry for reassembling, scribe mark the steering arm and ski leg before disassembly.



1. Marks

#### 10, Bushing

Unscrew ball joint no. 18 from steering arm.

Unscrew sliding rod no. 9.

Detach rubber boot from frame. Pull out sliding rod. Working from engine compartment, drive out bushing no. 10.

Install a new bushing proceeding from front suspension pit.

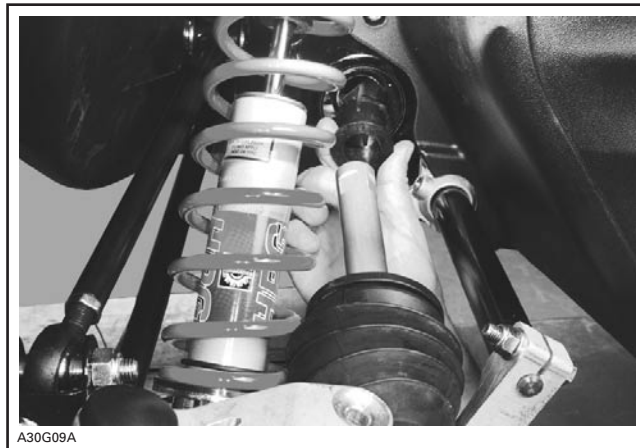

BUSHING INSTALLATION

## Section 08 STEERING/FRONT SUSPENSION

### Subsection 02 (STEERING SYSTEM)

#### 21, Bracket

Bracket must be installed at 90° from top of center ball joint.

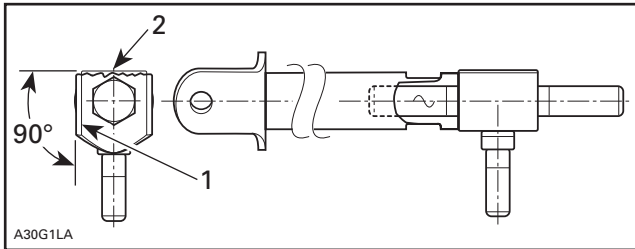

FRONT VIEW AND SIDE VIEW

1. Bracket
2. Top of center ball joint

#### 17,18, Ball Joint (left hand and right hand threads)

The maximum external threaded length not engaged in the tie rod must not exceed 20 mm (25/32 in).

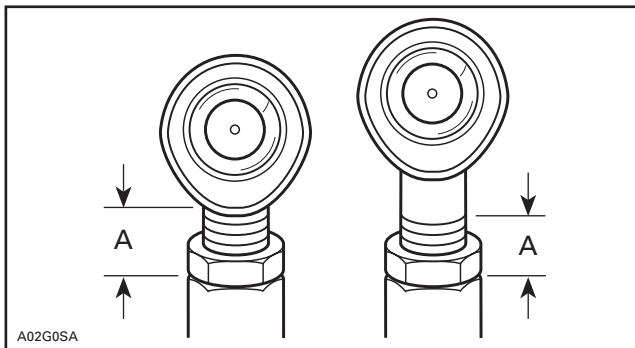

TYPICAL

A. 20 mm (25/32 in) max.

The ball joint should be restrained when tightening the tie rod end lock nut. Align it so the tie rod end cut-off section is parallel to the steering arm when assembled on the vehicle, refer to the following illustration.

For proper torque specifications refer to the specific exploded view for the vehicle being serviced.

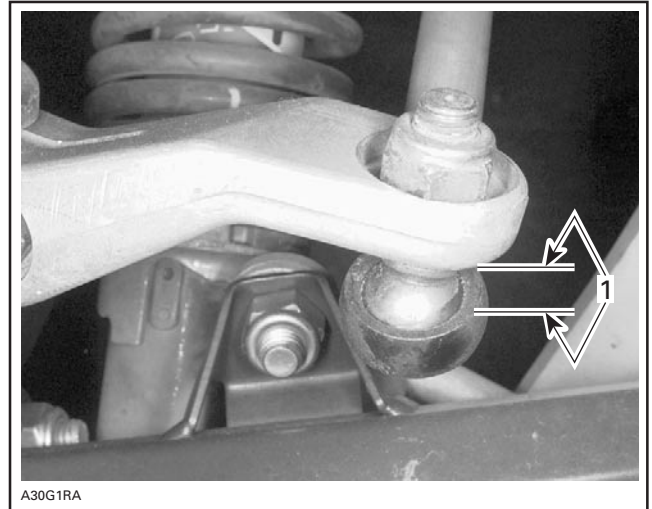

TYPICAL

1. Parallel

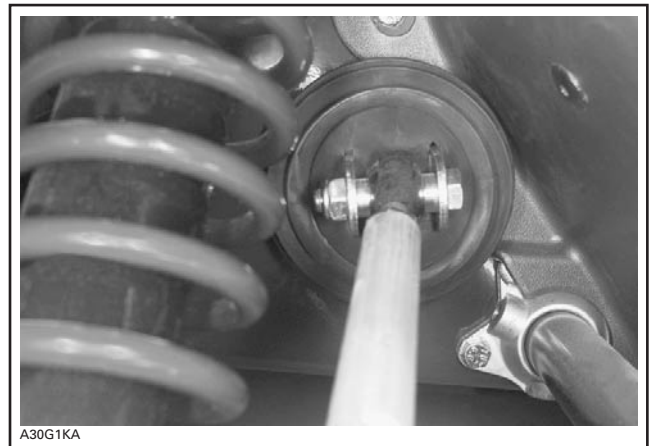

TIE ROD BALL JOINT PARALLEL TO BRACKET BEFORE TIGHTENING

#### **⚠ WARNING**

The cut off section of the ball joint must run parallel with the steering arm. When tightening lock nuts, restrain ball joint with appropriate size wrench. The maximum external threaded length not engaged in the tie rod must not exceed 20 mm (25/32 in).



## Section 08 STEERING/FRONT SUSPENSION

### Subsection 02 (STEERING SYSTEM)

#### 7, Hardened Washer

Install a hardened washer on each side of the arm.

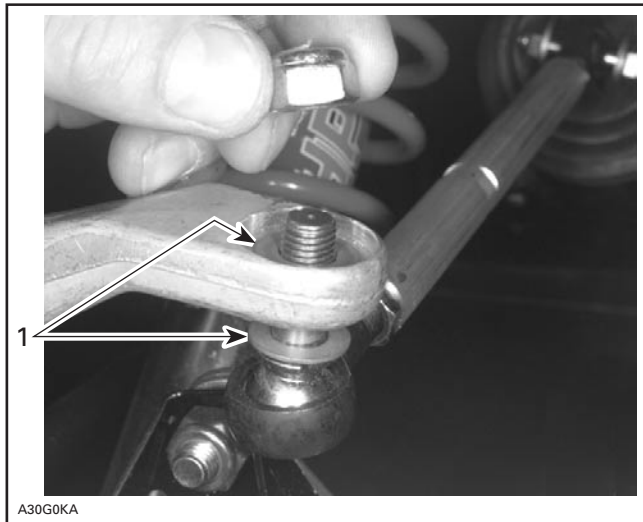

A30G0KA

1. Hardened washers

#### 12, Steering Arm

Steering arm axis (from plastic cap center to ball center of ball joint) must run parallel to ski.

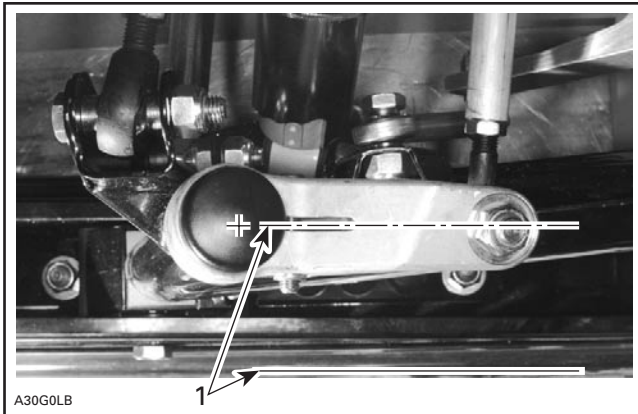

A30G0LB

1. Parallel

Tighten the steering arm pinch bolt and nut to the torque specified in the exploded view.

## INSPECTION

Check skis and runner shoes for wear, replace as necessary. Refer to FRONT SUSPENSION.

#### 12, Steering Arm

Make sure steering arm and ski leg splines interlock.

### **⚠ WARNING**

Any parts having worn splines have to be replaced with new ones.

Check the general condition of the steering system components for wear. Replace if necessary.

#### 15, Heating Grip Element

Refer to TESTING PROCEDURE.

#### 17,18, Ball Joint (left hand and right hand threads)

Inspect ball joint ends for wear or looseness, if excessive, replace them.

## HANDLEBAR ADJUSTMENT

### **Mach Z SPORT**

Loosen all 4 nuts no. 4 retaining steering clamps no. 2.

Adjust the steering handlebar to the desired position.

### **Mach Z TECH PLUS**

With tilt handlebar mechanism is upper position, install handlebar at 121° from steering column.

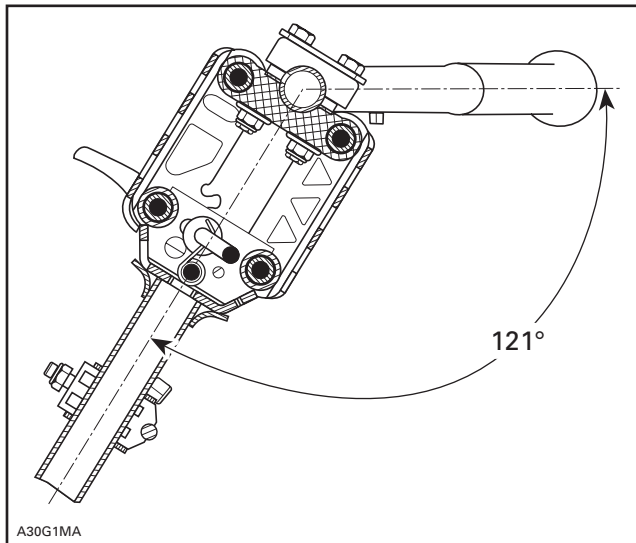

A30G1MA

## Section 08 STEERING/FRONT SUSPENSION

### Subsection 02 (STEERING SYSTEM)

#### All Models

Lock the handlebar in place by tightening the 4 nuts as specified in the illustrations.

**CAUTION:** Tighten the nuts equally in a criss-cross sequence and ensure there is an equal gap on each side of the clamps.

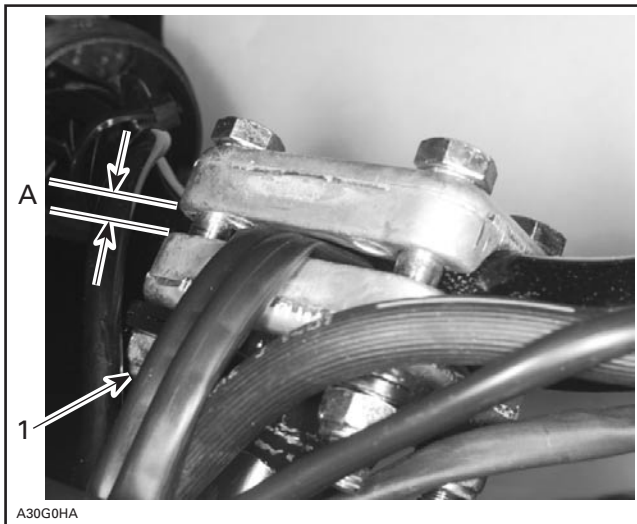

#### TYPICAL

1. Torque to 23 N•m (17 lbf•ft)
- A. Equal gap all around

#### **⚠ WARNING**

Avoid contact between the brake handle and the windshield by NOT adjusting the handlebar too high.

#### **⚠ WARNING**

Make sure that the steering pad and all controls are properly fixed to their normal location on the handlebar.

#### 19,20, Steering Pad and Rubber Attachment

**CAUTION:** Prior to installation, perform handlebar adjustment.

Properly fit the steering pad to the handlebar. Assemble using the 2 rubber attachments.

#### **⚠ WARNING**

Make sure that the steering pad and all controls are properly fixed to their normal location on the handlebar.

## STEERING ADJUSTMENT (skis)

### Definitions

#### TOE-OUT:

A difference measured between the front edge of the skis "A" and rear edge "B" as viewed from the top. It is adjustable. For all CK3 models, toe-out is measured at 220 mm (8-21/32 in) from ski pivot bolt axis.

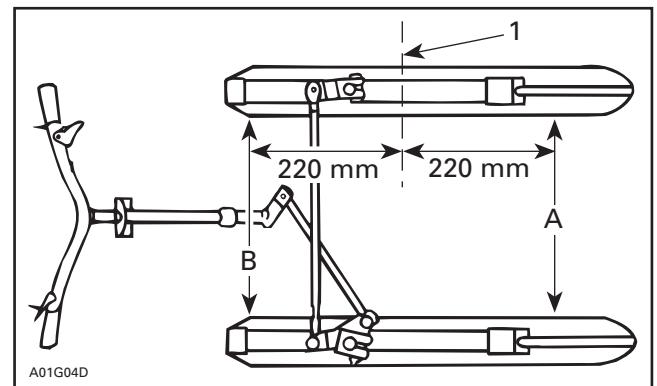

#### TYPICAL

1. Ski pivot bolt axis

#### CAMBER:

A specific inward or outward tilt angle of ski leg compared to a vertical line when viewing the vehicle from front.

### Adjustments

Adjustments should be performed following this sequence:

- Pivot arm centering.
- Set camber angle.
- Set toe-out.

#### PIVOT ARM CENTERING

#### **⚠ WARNING**

Do not attempt to adjust straight ahead ski position by turning the ball joint on tie rod no. 8.

## Section 08 STEERING/FRONT SUSPENSION

### Subsection 02 (STEERING SYSTEM)

#### 8,17,18,21, Tie Rod, Ball Joint and Bracket

Remove steering pad.

Turn handlebar all the way to the right. Check that the right side bracket no. 21 is against the bushing no. 10.

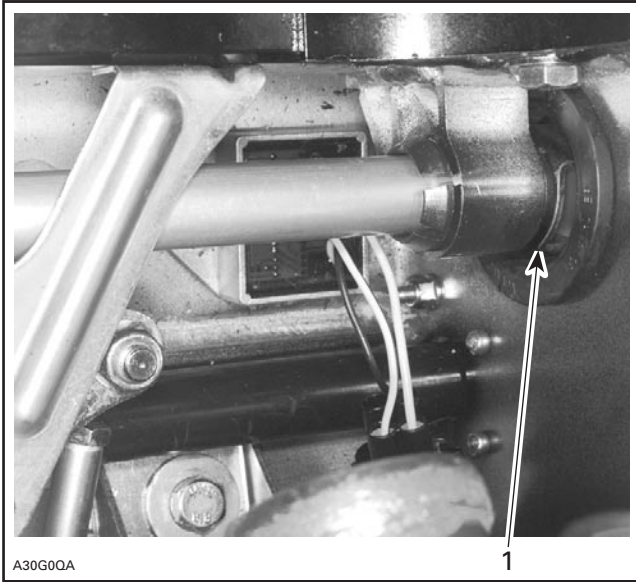

1. Bracket against the bushing

Keeping the handlebar in that position, check that the stopper on the steering column is almost touching the plate.

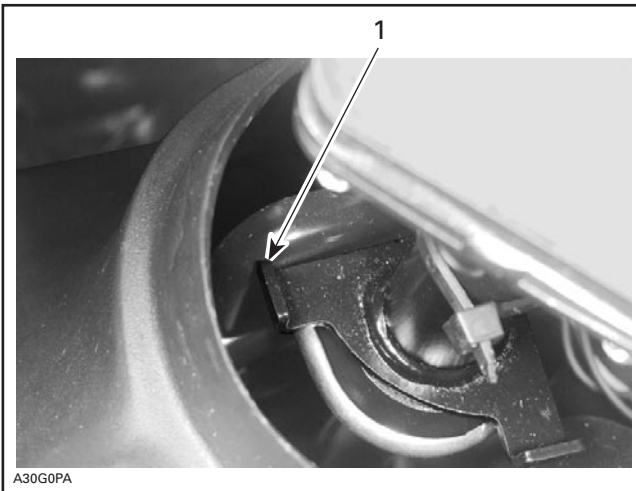

1. Stopper almost touching the plate

Loosen the jam nuts on tie rod no. 8 (LH threads on steering column end) and turn tie rod accordingly. Align and retighten the jam nuts to 18 N•m (159 lbf•in).

#### **⚠ WARNING**

Never lengthen this tie rod so that threaded portion of ball joint exceeds 20 mm (25/32 in).

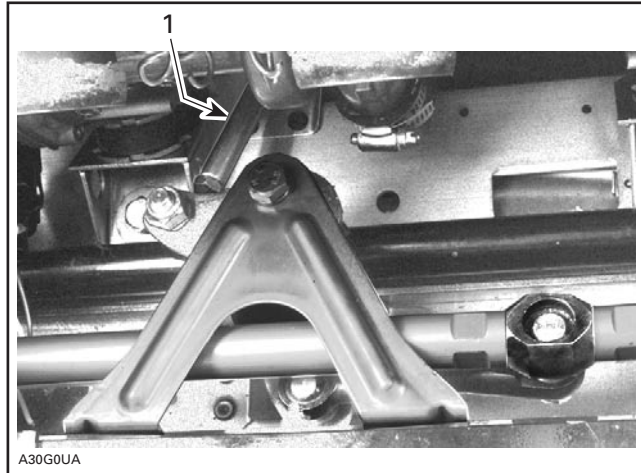

1. Tie rod no. 8

#### CAMBER

**NOTE:** Identical adjustments are required on both sides of the vehicle.

- Make sure the vehicle is leveled by placing an angle finder under the main frame member as shown on the following illustration.
- Vehicle skis must be off the ground.

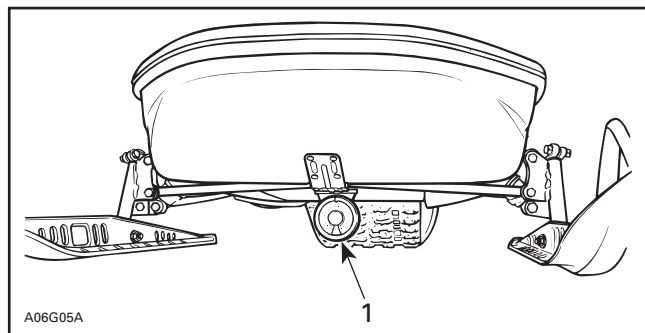

#### TYPICAL

1. Angle finder

## Section 08 STEERING/FRONT SUSPENSION

### Subsection 02 (STEERING SYSTEM)

Using special tool (P/N 529 021 600) mounted to the ski leg, position the angle finder on the tool as shown in the following illustration. An alternate location for the angle finder if the special tool is not available is the outside of the ski leg housing.

**CAUTION:** Angle finder must sit square against swing arm. Positioning angle finder against weld bead or decal may result in false reading.

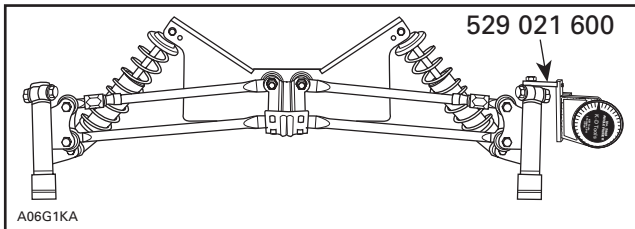

TYPICAL — CAMBER ADJUSTMENT SET-UP

#### Adjusting

- Loosen lock nut on both upper control arms.
- Unbolt both upper control arms at ski leg housing. Turn tie rod half turn at a time to obtain the specified value when skis are not touching ground. Bolt upper control arms.

MODEL	CAMBER $\pm 0.5^\circ$
Mach Z SPORT/TECH PLUS	- 0.5

**NOTE:** Because of a negative camber, skis will lean toward center of vehicle.

Tighten lock nut on both upper control arms.

#### SKI TOE-OUT

Lift front of vehicle off the ground.

Make sure that handlebar is in straight ahead position by measuring from the extremities of the grips to the rearmost edge of the tunnel, as shown.

**NOTE:** The reference point must be the same relative to each side.

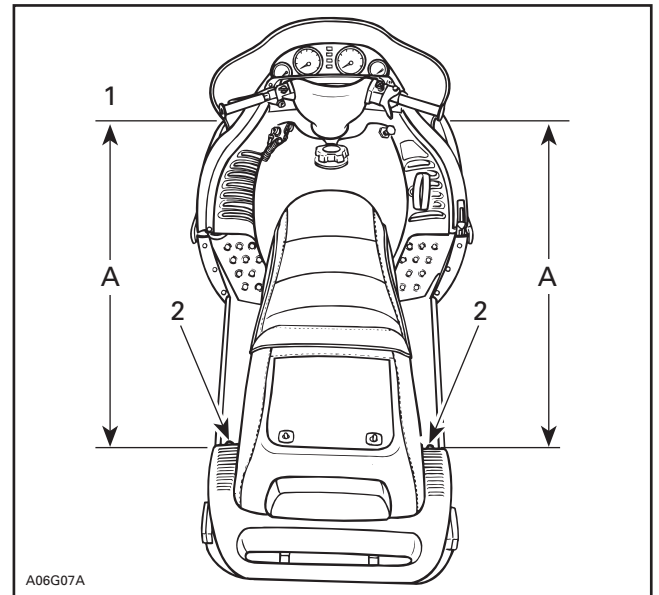

TYPICAL

1. Equal distance A on each side
2. Same reference point

#### **WARNING**

Do not attempt to adjust skis straight ahead position by turning ball joint on tie rod **no. 8**.

Loosen jam nuts of both tie rods **no. 11**.

**NOTE:** Hook a rubber cord in front of skis to keep them closed and to eliminate all free play.

Toe-out must be as specified when skis are in a straight-ahead position and the front of vehicle is lifted off the ground.

MODEL	TOTAL TOE-OUT + 3 mm (+ 1/8 in) - 0 mm (- 0 in)
Mach Z SPORT/TECH PLUS	8 (5/16)

Place a straight edge against pre-adjusted track and measure the distance between front and rear of skis and straight edge. Measuring points are 220 mm (8-21/32 in) at front and rear of ski pivot axis.

## Section 08 STEERING/FRONT SUSPENSION

### Subsection 02 (STEERING SYSTEM)

To reduce tolerance when measuring, set one ski to proper toe-out (half the total toe-out) then measure from that ski to the opposite ski.

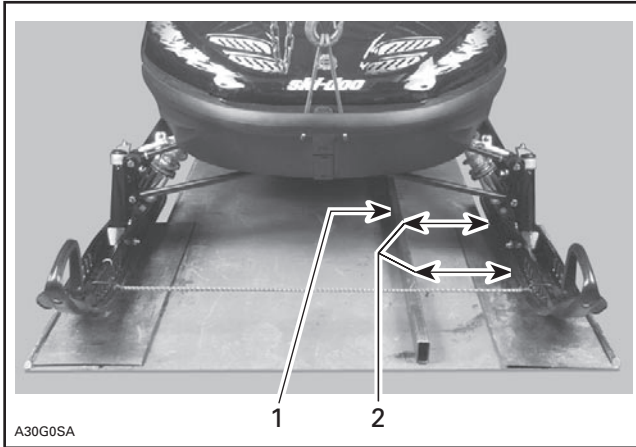

1. Straight edge
2. Measure at 220 mm (8-21/32 in) from ski pivot axis

## LUBRICATION

### WARNING

Do not lubricate throttle cable or housing.

## 26, Grease Fittings

Only use synthetic grease (P/N 413 711 500).

The following symbols will be used to show what type of lubricant should be used at the suitable locations.

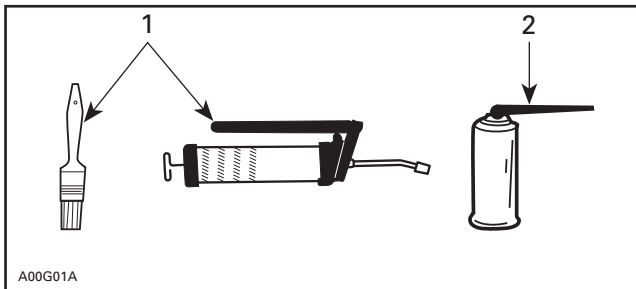

1. Synthetic grease (P/N 413 711 500)
2. BOMBARDIER LUBE (P/N 293 600 016)

## Lubricate:

- steering column bushings
- short tie rod ends
- ball stud lever
- upper arm ball joint
- ski legs
- stabilizer ball joints.

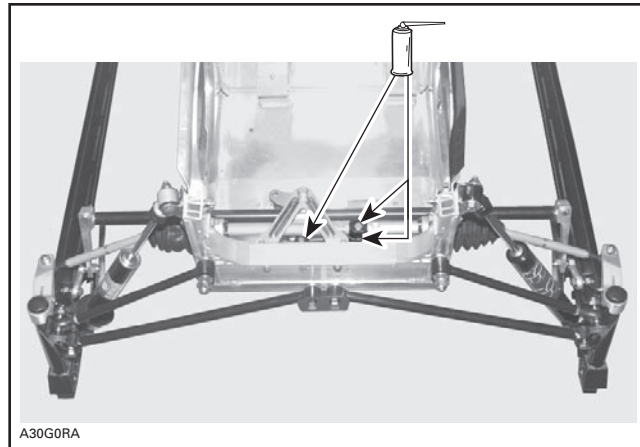

A30G0RA

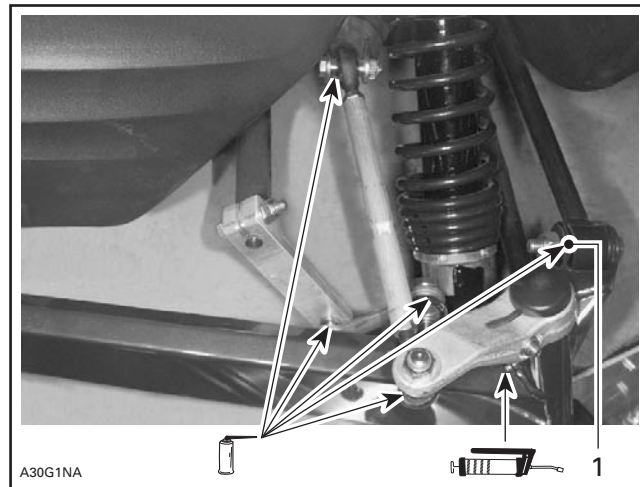

A30G1NA

## TYPICAL

1. Upper arm ball joint on Mach Z SPORT/TECH PLUS only

# SUSPENSION AND SKI SYSTEM

*CK3 Series*

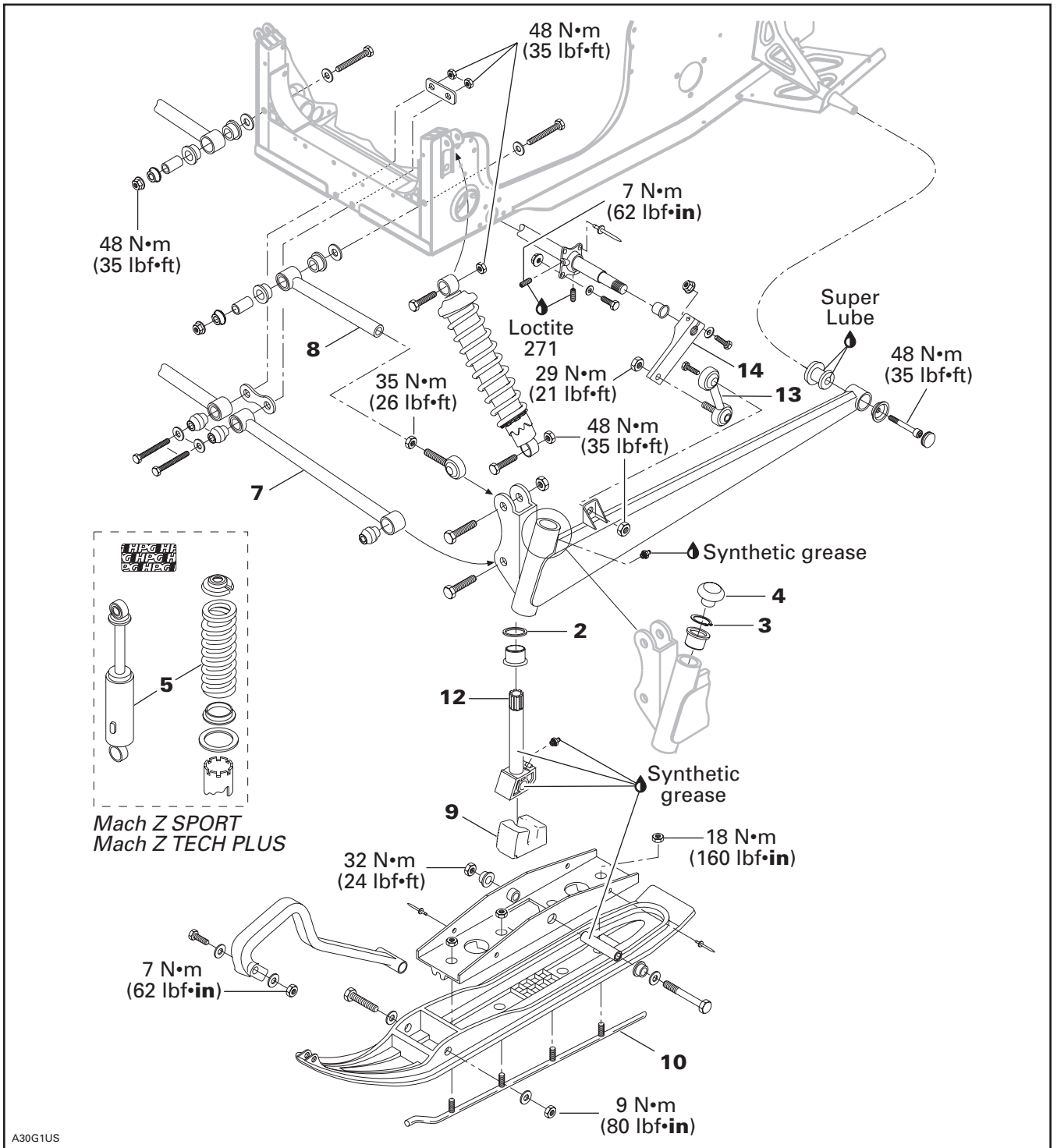

## Section 08 STEERING/FRONT SUSPENSION

### Subsection 03 (SUSPENSION AND SKI SYSTEM)

## DISASSEMBLY

### 5, Shock

Lift front of vehicle and support it off the ground.

Reduce spring preload by turning adjusting ring accordingly with the adjustment wrench in vehicle tool box.

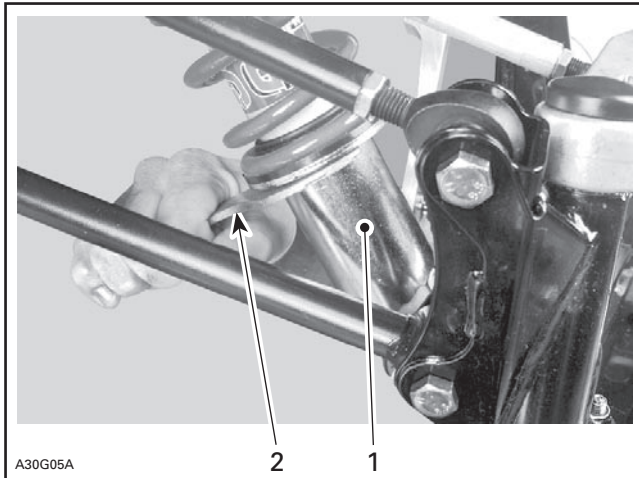

#### TYPICAL

1. Shock cam
2. Adjustment wrench

Remove lower bolt then upper bolt of shock.

For shock spring disassembly use shock spring remover (P/N 529 027 100) in a vise. Mount shock in it and turn shock so that spring coils matched spring compressor.

Close and lock the bar. Adjust the handle horizontal position by changing the position of the clevis pin.

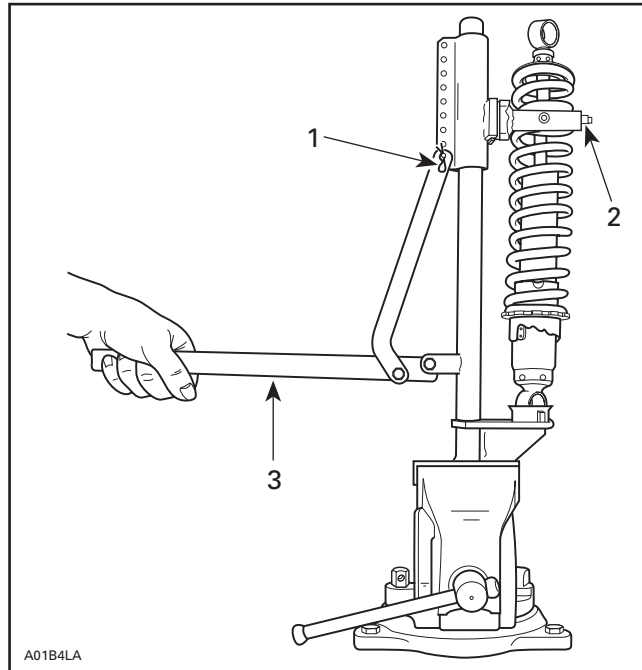

1. Clevis pin
2. Bar
3. Handle horizontal

Push down on the handle until it locks. Remove spring stopper then release handle.

### 1, Swing Arm

Lift front of vehicle and support it off the ground.

Remove cap **no. 4**, circlip **no. 3** then loosen steering arm bolt and pull up steering arm. Ski leg may fall off from swing arm. Note washer **no. 2** position.

Unbolt lower end of shock from swing arm.

Unbolt arms.

Unbolt tie rod **no. 13** ball joint from swing arm.

Unbolt rear of swing arm from frame.

Pull swing arm off the vehicle.

## INSPECTION

Check all rubber cushions for crack and wear. Replace as required.

Check straightness of ski leg **no. 12** and make sure that splines are properly interlocking with steering arm. Replace as required.

Check for straightness of swing arm. Replace as required.

Check for clogged grease fittings. Clean or replace as required.

Check skis and runners **no. 10** for wear, replace as necessary.

Check condition of ski stopper **no. 9**. Replace it when deteriorated.

To check condition of shock, refer to SC-10 II SUSPENSION then look for **Shock Absorber Inspection**.

## INSTALLATION

For assembly, reverse the disassembly procedure. However, pay attention to the following.

Apply synthetic grease (P/N 413 711 500) to ski leg components.

Tighten nuts and screws to proper torque as mentioned in exploded view.

## 7,8, Upper and Lower Half Arms

Position half arms and tie rods horizontally before tightening nuts.

## 8, Adjustable Arm

Refer to STEERING SYSTEM for proper camber adjustment using these arms.

## 13,14, Tie Rod and Lever

Install levers pointing downward on both sides at same angle, see following photo.

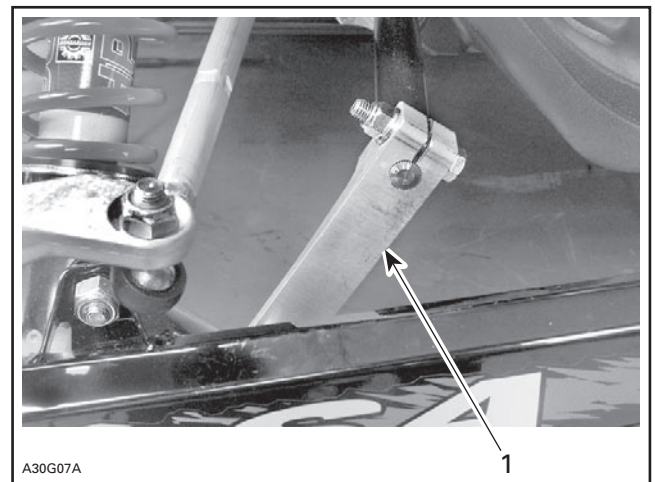

1. Lever pointing downward