



1. Regulator/Rectifier
2. Starter Support PTO Side
3. Hexagonal Screw M8 x 20 (3)
4. Lock Washer M8 (6)
5. Hexagonal Screw M8 x 25 (2)
6. Starter
7. Starter Support MAG Side
8. Flanged Elastic Nut M5 (2)
9. Flat Washer M6 (2)
10. Flat Washer M8 (2)
11. Carriage Bolt M6 x 20
12. Ring Gear
13. Self-Tapping Screw M8 x 16 (6)
14. BLACK Negative Ground Cable
15. Star Washer M6
16. Flanged Elastic Nut M6
17. RED Positive Battery Cable
18. Protector Cap (at starter)
19. Hexagonal Nut M8
20. Self-Tapping Screw M6 x 12
21. Clip
22. Fusible Wiring Harness
23. Switch
24. Star Lock Washer
25. Face Nut
26. Switch Protector (not illustrated)
27. Battery Seat
28. Deflector
29. Battery
30. Steel Strip (2)
31. Hexagonal Screw M5 x 16 (3)
32. Elastic Stop Nut M5 (3)
33. Elastic Stop Nut M10 (2)
34. Protector Cap (at battery)
35. Tubing
36. Decal
37. Locking Tie (8)
38. Counterweight
39. Starting Pulley
40. Hexagonal Screw M8 x 20 (3)
41. Lock Washer M8 (3)
42. Protector
43. Insert (2)
44. Hexagonal Flanged Screw M6 x 16 (2)
45. Black Rubber Plug (2) (not illustrated)

## INSTRUCTIONS

### Vehicle Preparation

Remove tuned pipe, muffler, belt guard, drive belt, air intake silencer.

Loosen drive pulley retaining screw for later removal.

### Regulator/Rectifier

Remove original regulator/rectifier, located along RH side member of frame. Secure regulator/rectifier **no. 1** on both sides with same self-tapping bolts.

Apply silicone dielectric grease (P/N 293 550 004) in regulator/rectifier connector and then connect it to vehicle harness connector. Secure connectors with a locking tie **no. 37**.

### Ignition Switch

Remove steering pad.

Remove upper screw retaining both left and right consoles.

Remove fuel tank cap and retaining ring.

Using template, found on the last page of the current document, properly positioned on dash, mark center hole for switch location, beside DESS connector.

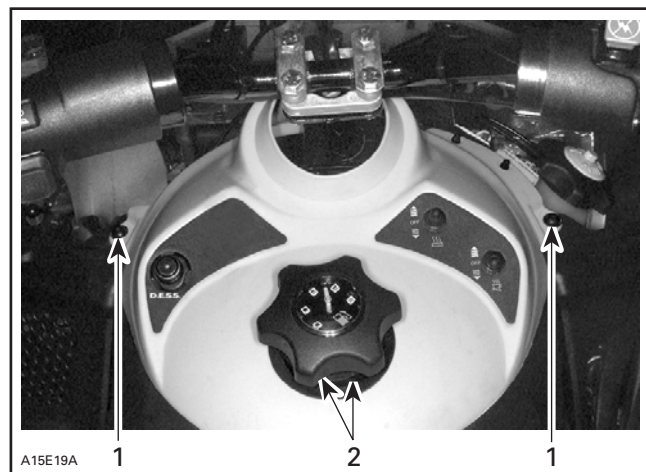

**WITH STEERING PAD REMOVED**

1. Remove these screws
2. Remove cap and retaining ring

Using a 19 mm (3/4 in) hole saw, drill through dash.

Tighten nut onto ignition switch **no. 23**, slide star lock washer **no. 24** onto switch then insert switch through hole from underneath and secure on top with face nut **no. 25**.

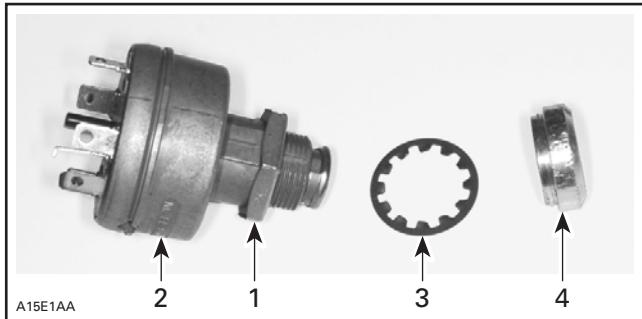

1. Nut
2. Ignition switch
3. Star lock washer
4. Face nut

Install rubber protector **no. 26** on top of switch. Connect fusible wiring harness **no. 22** to ignition switch then, lift dash and route wiring harness behind steering column but in front of heated thumb/handle connectors, leading toward battery area.

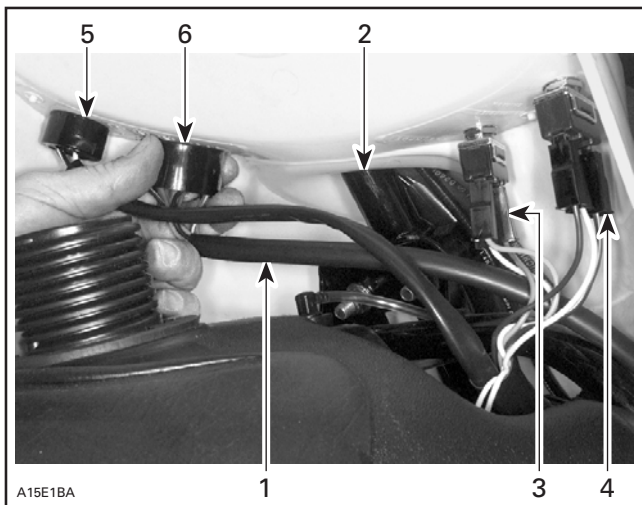

1. Fusible wiring harness
2. Steering column
3. Heated handle connector
4. Heated thumb connector
5. DESS connector
6. Ignition switch connector

Open multi-connector and insert terminals in proper holes as follows:

- BLACK wire in hole no. 15.
- BLACK/YELLOW wire in hole no. 14.
- RED/BLUE wire in hole no. 13.
- RED/WHITE wire in hole no. 12.
- RED/GREEN wire in hole no. 11.

Close multi-connector.

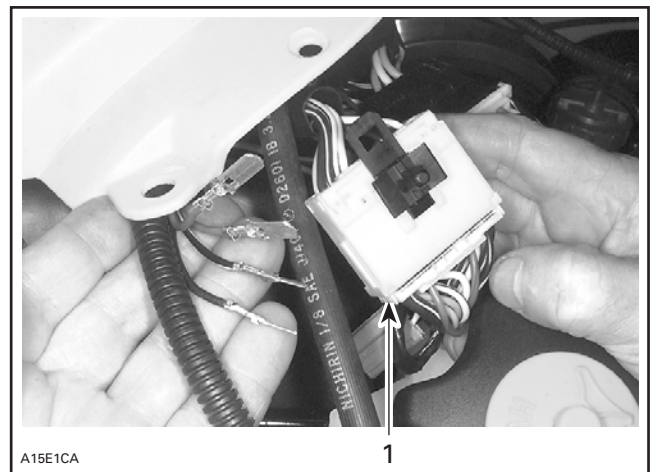

1. Use this multi-connector

## Flywheel and Starting Pulley

Remove rewind starter.

Unscrew starting pulley. Remove it and install counterweight **no. 38** and new starting pulley **no. 39**.

Secure with screws **no. 40** and lock washers **no. 41**. Apply Loctite 243 on threads.

Torque to 21 N•m (15 lbf•ft).

Reinstall rewind starter.

## Ring Gear

Remove drive pulley. Refer to appropriate *Shop Manual* to perform drive pulley disassembly/assembly procedures and to proceed with pulley alignment.

Secure ring gear **no. 12** on inner half using self-tapping screws **no. 13**. Apply Loctite 271 (red) on screw threads.

**CAUTION:** Loctite 271 (red) must be applied to safely assemble ring gear.

Torque screws in a criss-cross sequence to 27 N•m (20 lbf•ft).

Do not reinstall drive pulley at this time.

## Protector Installation

Align protector **no. 42** with left most hole on frame front wall and use protector as a template to drill second hole. See photo page 6.

Using a 10 mm (25/64 in) bit, drill second hole.

From outside, slide inserts **no. 43** in holes.

Squeeze it tight on frame by tightening a screw **no. 44** on the outside and retaining the insert with a pair of pliers on the inside.

Once insert squeezed, remove screw **no. 44**.

## Electric Starter

**CAUTION:** Apply Loctite 271 (red) on all fastener threads of starter supports.

From main harness underneath engine cut locking tie and pull out RED wire with the eyelet terminal toward the starter position.

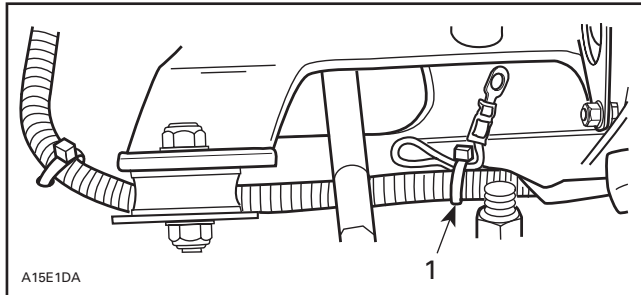

1. Locking tie

Install starter support PTO side **no. 2** to engine using hexagonal screws **no. 3** and lock washers **no. 4**. Tighten firmly.

Install electric starter **no. 6** on support, bottom bolts first and secure it using M8 x 25 hexagonal screws **no. 5** and lock washers M8 **no. 4**.

Install flat washers M6 **no. 9** over nuts of starter through bolts.

Install starter support MAG side **no. 7** to starter after inserting carriage bolt **no. 11**, and secure with M5 flanged elastic nuts **no. 8**.

Secure support to engine with M8 x 20 hexagonal screw **no. 3**, flat washer **no. 10** and lock washer **no. 4**.

## Wire/Cable Connections and Routing

Starting from starter location, route battery cables toward battery location along vehicle harness. The biggest hole of the RED positive cable connects to the starter.

Slide tubing **no. 35** protector cap **no. 18** (starter end of cable) and protector cap **no. 34** (battery end of cable) on RED positive battery cable **no. 17**. Install cable, flat washer M8 **no. 10**, lock washer M8 **no. 4** and nut M8 **no. 19** to starter solenoid, turn cable angle as much as possible towards the engine. Cover terminal with previously installed protector cap.

Connect and secure RED wire with eyelet terminal, previously pulled from main harness, to starter solenoid.

Connect battery BLACK negative cable **no. 14** to starter bracket carriage bolt using star washer **no. 15** between bracket and terminal; secure with elastic nut **no. 16**.

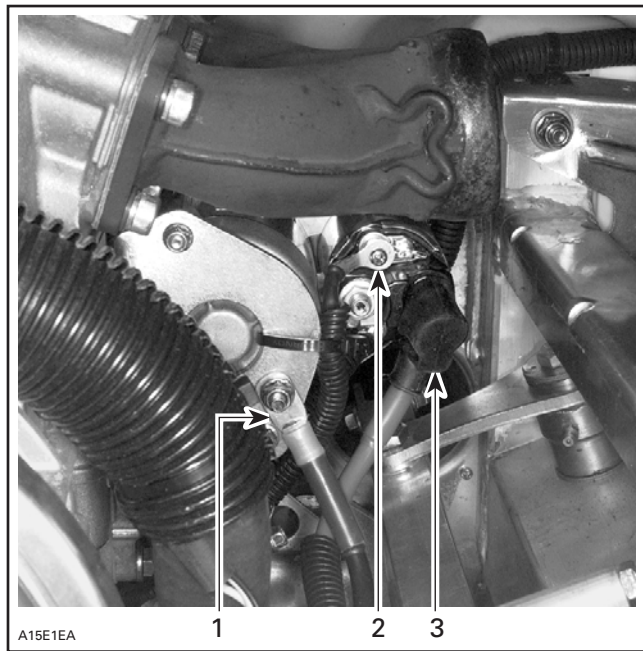

1. BLACK negative cable connected to starter support MAG side
2. RED wire with eyelet terminal connected to solenoid
3. RED positive cable connected to solenoid

Route both cables toward battery alongside engine harness and secure with locking ties **no. 37** every 150 mm (6 in) more or less.

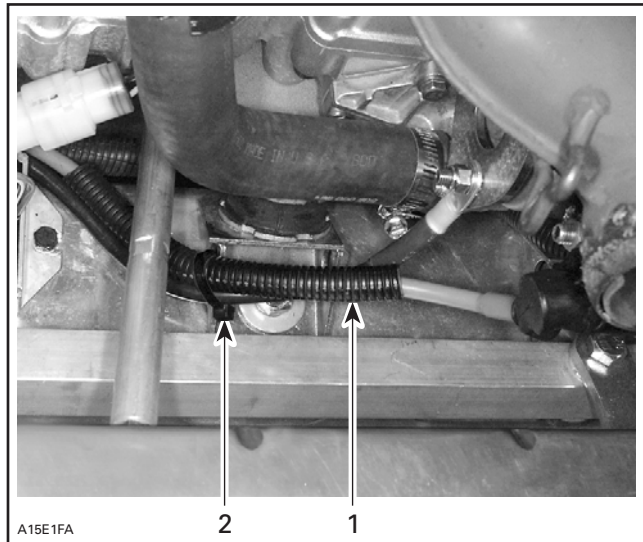

1. Tubing **no. 35**
2. Locking tie

Cables must pass underneath rewind starter cord, under countershaft, behind oil reservoir and on top of choke cables, toward battery.

Drill a 5 mm (13/64 in) hole and retain both cables with clip **no. 21** at the rewind starter cord area, using self-tapping screw **no. 20**.



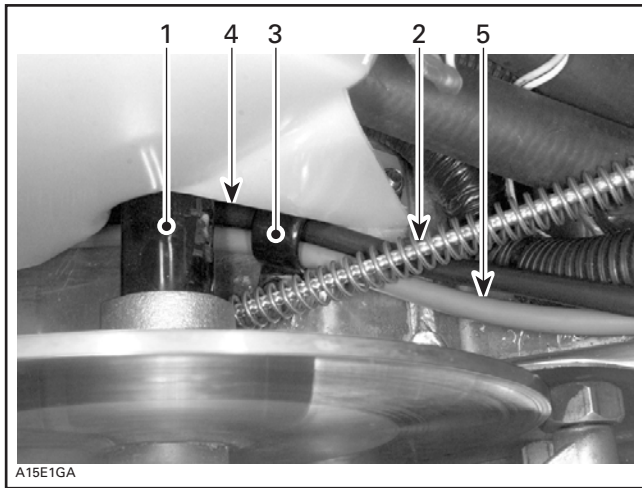

A15E1GA

1. Countershaft
2. Rewind starter rope
3. Clip no. 21
4. BLACK negative cable
5. RED positive cable

To ease cable routing, undo coolant reservoir retaining screw just enough to push reservoir forward a bit.

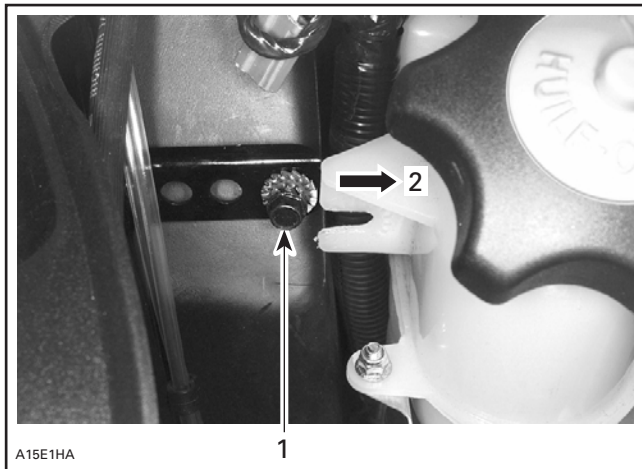

A15E1HA

1. Loosen this bolt
2. Move a bit forward

### **⚠ WARNING**

Ensure all terminals are properly crimped on wires/cables and that all connector housings are properly fastened. Keep wires away from any rotating, moving, heating, vibrating and sharp edge parts. Use proper fastening devices as required.

## Battery and Rack

Remove 2 lower nuts retaining chaincase cover. Install battery rack no. 27 as shown and secure with 2 screws no. 31 and 2 elastic nuts no. 32 on top of right front foot rest and reinstall new chaincase cover nuts no. 33.

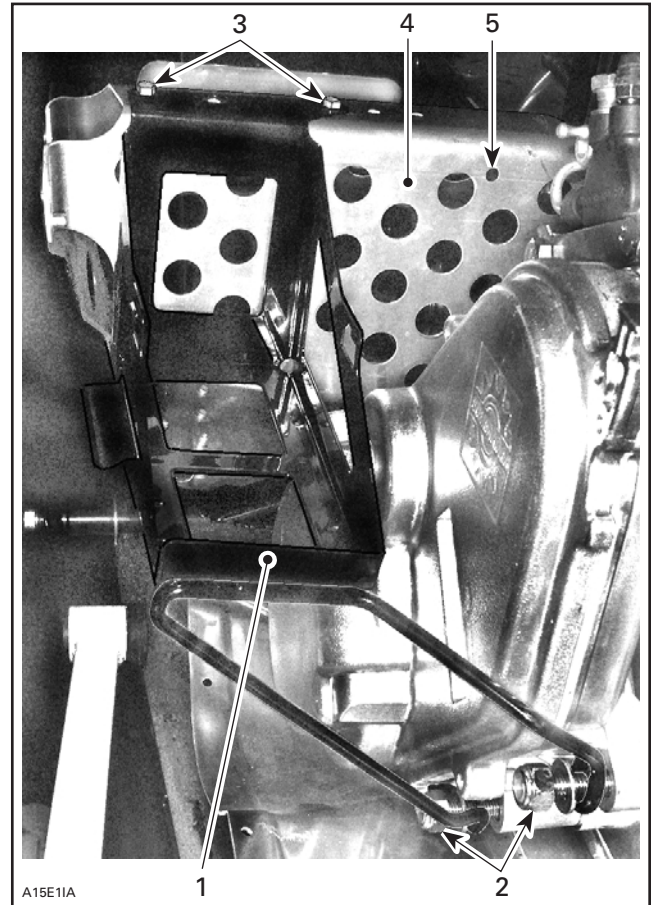

A15E1IA

1. Battery rack
2. Change these 2 nuts
3. Secure with 2 screws no. 31 and 2 nuts no. 32
4. Footrest
5. Ground hole

Install battery no. 29 in rack, posts on engine side, with deflector no. 28.

Connect RED positive battery cable and RED wire with fuse (from ignition switch harness) to battery then connect BLACK ground cable. Secure BLACK negative cable in indentation of the battery retaining steel strip, engine side.

### **⚠ WARNING**

Always connect the battery cables exactly in the specified order. Connect RED positive cable first, then BLACK negative ground cable.

Secure battery in place with steel strips no. 30, hexagonal screw no. 31 and elastic stop nut no. 32. Hook up fuse holder to retaining steel strip. Fasten battery cables using a locking tie no. 37.

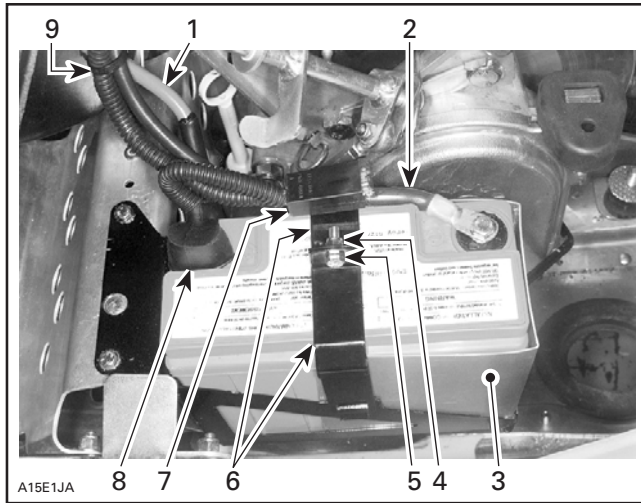

1. RED positive cable
2. BLACK negative cable
3. Deflector no. 28
4. Elastic stop nut no. 32
5. Hexagonal nut no. 31
6. Steel strips no. 30
7. Fuse holder
8. Protector cap no. 34
9. Locking tie

Install black rubber plugs no. 45 on protector no. 42. Position protector in place. Secure with screws no. 44.

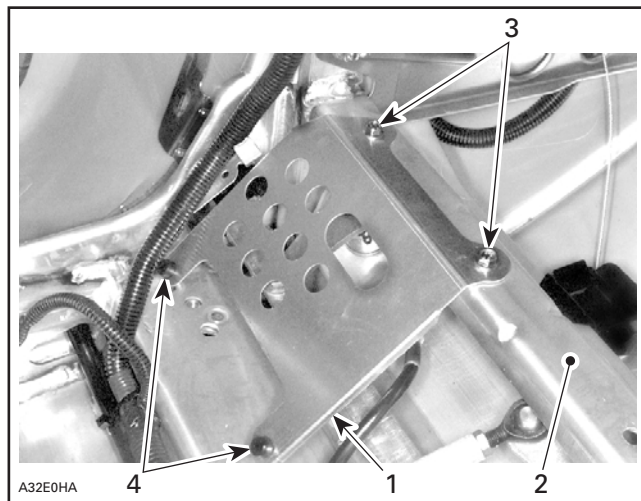

**ENGINE REMOVED**

1. Protector
2. Snowmobile frame
3. Hexagonal screws
4. Rubber plugs

## Finalizing Assembly

Refer to the appropriate *Ski-Doo Shop Manual* for proper reinstallation procedure.

Reinstall drive pulley.

Check pulley alignment.

### **WARNING**

Drive pulley alignment must always be checked whenever pulleys have been removed, replaced or disassembled.

Reinstall remaining removed parts not forgetting to secure coolant reservoir retaining screw.

**NOTE:** Apply Dow Corning sealer no. 736 RTV on exhaust manifold ball joint.

Test electrical starting and ignition cut-out systems as per normal starting procedure for electric starter models.

## Decal

Clean decal region with soapy water or isopropyl alcohol using a soft clean cloth and dry thoroughly.

**CAUTION:** Do not apply isopropyl alcohol on decal.

Remove backing from decal.

Apply decal no. 36 on left side of hood.

# TEMPLATE

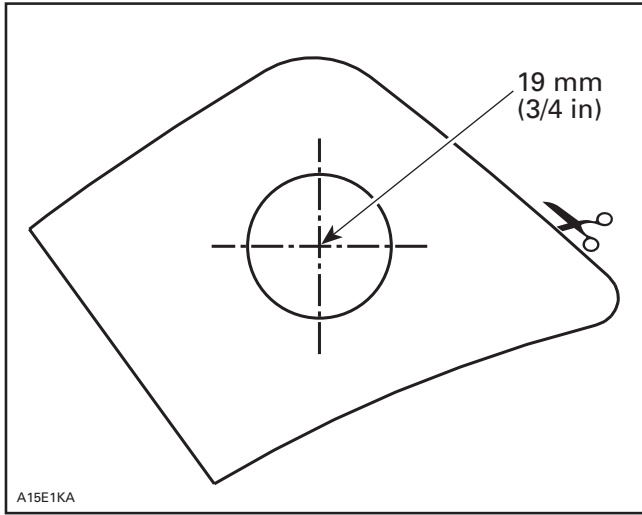

## 861 504 600

1.	515 175 217	Regulator/Rectifier	Régulateur/redresseur
2.	515 175 142	Starter Support PTO Side	Support de démarreur, côté PDM
3.	207 182 044	Hexagonal Screw M8 x 20 (3)	Vis hexagonale M8 x 20 (3)
4.	234 181 401	Lock Washer M8 (6)	Rondelle-frein M8 (6)
5.	207 182 544	Hexagonal Screw M8 x 25 (2)	Vis hexagonale M8 x 25 (2)
6.	515 175 564	Starter	Démarreur
7.	515 175 143	Starter Support MAG Side	Support de démarreur, côté MAG
8.	233 251 414	Flanged Elastic Nut M5 (2)	Écrou élastique à épaulement M5 (2)
9.	391 301 700	Flat Washer M6 (2)	Rondelle plate M6 (2)
10.	234 081 410	Flat Washer M8 (2)	Rondelle plate M8 (2)
11.	207 762 044	Carriage Bolt M6 x 20	Boulon de carrosserie M6 x 20
12.	417 300 057	Ring Gear	Couronne de lancement
13.	236 281 684	Self-Tapping Screw M8 x 16 (6)	Vis autotaraudeuse M8 x 16 (6)
14.	515 175 168	BLACK Negative Ground Cable	Câble de masse négatif NOIR
15.	394 001 900	Star Washer M6	Rondelle en étoile M6
16.	233 261 414	Flanged Elastic Nut M6	Écrou élastique à épaulement M6
17.	515 175 167	RED Positive Battery Cable	Câble positif de batterie ROUGE
18.	570 064 200	Protector Cap (at starter)	Capuchon de protection (démarreur)
19.	232 081 414	Hexagonal Nut M8	Écrou hexagonal M8
20.	210 361 280	Self-Tapping Screw M6 x 12	Vis autotaraudeuse M6 x 12
21.	415 018 200	Clip	Pince
22.	515 175 171	Fusible Wiring Harness	Faisceau de fils de fusible
23.	410 111 300	Switch	Interrupteur
24.	394 103 300	Star Lock Washer	Rondelle-frein en étoile
25.	410 112 100	Face Nut	Écrou
26.	570 013 700	Switch Protector	Cache d'interrupteur
27.	515 175 243	Battery Seat	Siège de batterie
28.	515 175 363	Deflector	Défecteur
29.	515 175 481	Battery	Batterie
30.	515 175 226	Steel Strip (2)	Bande d'acier (2)
31.	207 151 644	Hexagonal Screw M5 x 16 (3)	Vis hexagonale M5 x 16 (3)
32.	233 251 414	Elastic Stop Nut M5 (3)	Écrou d'arrêt élastique M5 (3)
33.	233 601 416	Elastic Stop Nut M10 (2)	Écrou d'arrêt élastique M10 (2)
34.	570 151 000	Protector Cap (at battery)	Capuchon de protection (batterie)
35.	415 079 900	Tubing	Tube
36.	418 001 300	Decal	Autocollant
37.	414 115 200	Locking Tie (8)	Attache (8)



## 861 504 600

38.	420 866 757	Counterweight	Contrepoids
39.	420 852 411	Starting Pulley	Poulie de démarrage
40.	207 182 044	Hexagonal Screw M8 x 20 (3)	Vis hexagonale M8 x 20 (3)
41.	420 945 752	Lock Washer M8 (3)	Rondelle-frein M8 (3)
42.	515 175 536	Protector	Protecteur
43.	415 107 300	Insert (2)	Pièce d'ancrage (2)
44.	207 661 644	Hexagonal Flanged Screw M6 x 16 (2)	Vis hexagonale à épaulement M6 x 16 (2)
45.	293 830 005	Black Rubber Plug (2)	Bouchon de caoutchouc noir (2)