



**ADJUSTABLE WINDSHIELD**  
**(P/N 861 777 300)**

**⚠ WARNING**

For safety reasons, this kit must be installed by an authorized Ski-Doo® snowmobile dealer. Should removal of a locking device (e.g. lock tabs, self-locking fasteners, etc.) be required when undergoing disassembly/assembly, always replace with a new one. This instruction sheet should be given to the purchaser. This kit is designed for specific applicable models only. It is not recommended for units other than those for which it was sold.

NOTE: Installation time is approximately 0.4 hour.

**PARTS TO BE INSTALLED**  
**(not illustrated)**

1. Windshield
2. Stud (10)
3. Push Nut (10)
4. Washer (10)
5. Handle Assembly (RH)
6. Handle Assembly (LH)
7. Plate Assembly (RH)
8. Plate Assembly (LH)
9. Screw (2)

**PROCEDURE**

Lift hood and remove existing windshield by removing all retaining latches.

Deposit windshield on a piece of carboard on a working bench.

Separate windshield from its base by removing all retaining studs and push nuts.

Align new windshield **no. 1** with base and insert both right and left plates, **no. 7** and **no. 8**, between windshield and base, with their felt surface on windshield. Refer to following photo.

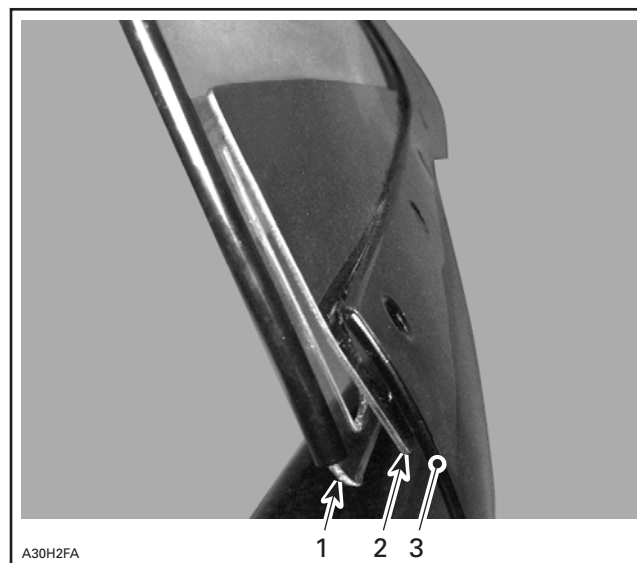

**RIGHT SIDE SHOWN**

1. Windshield *no. 1*
2. Plate *no. 7*
3. Base

Secure windshield to base using supplied studs **no. 2**, washers **no. 4** and push nuts **no. 3**.

For the 2 most forward studs, when pressing the push nuts, leave a gap of 1 to 2 mm (3/64 to 5/64 in) between windshield and base to follow upward and downward movement of windshield; this gap should be allowed while windshield is in its full downward position. Refer to following illustration.

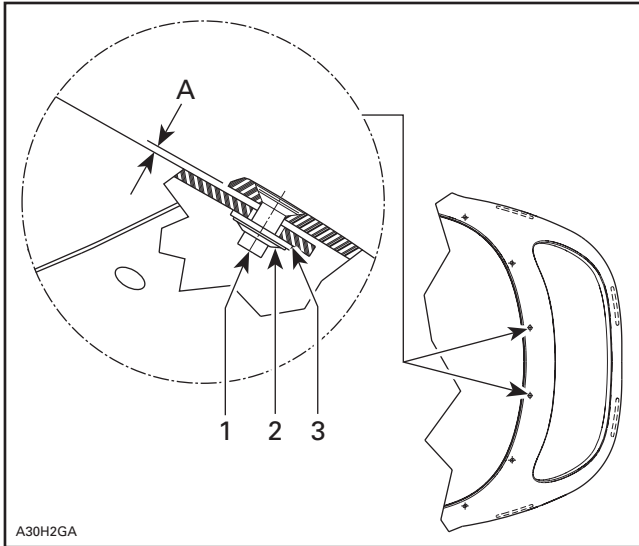

1. Stud no. 2
2. Push nut no. 3
3. Washer no. 4
- A. 1 to 2 mm (3/64 to 5/64 in)

Select proper handle for proper side by looking in position selection window: before or after position 5 a small letter R or L identifies the handle side. Refer to following photo.

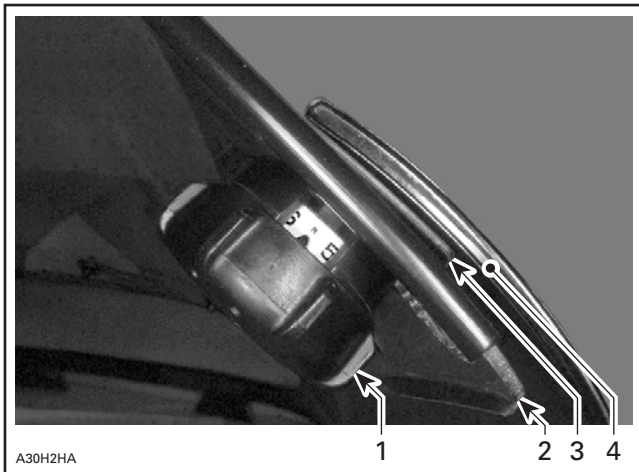

**RIGHT SIDE SHOWN**

1. Handle no. 5
2. Windshield no. 1
3. Plate no. 7
4. Base

Identify right side handle and start with that one. Gently block handles in a vise to raise selection to number 10 (fully lifted); make sure you've identified which is right side and which is left side.

Install right side handle, **no. 5**, from the inside, while holding base and windshield so to reach the fully lifted position.

**Handle goes in one way only.**

Secure handle from the outside using screw **no. 9**; tighten screw from 2 to 2.5 N•m (18 to 22 lbf•in). Refer to following illustration.

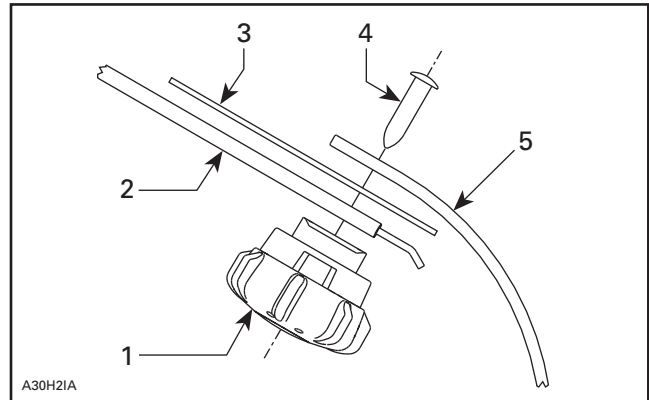

**RIGHT SIDE SHOWN**

1. Handle no. 5
2. Windshield no. 1
3. Plate no. 7
4. Screw no. 9
5. Base

Repeat procedure with left side handle **no. 6**.

Reinstall windshield in its position and retain with previously removed latches.

Clean windshield and its base.

Installation is now complete.

## 861 777 300

1.	517 302 480	Windshield	Pare-brise
2.	517 302 264	Stud (10)	Goujon (10)
3.	732 610 072	Push Nut (10)	Écrou à pression (10)
4.	517 302 265	Washer (10)	Rondelle (10)
5.	517 302 360	Handle Assembly (RH)	Poignée de droite (complet)
6.	517 302 361	Handle Assembly (LH)	Poignée de gauche (complet)
7.	517 302 509	Plate Assembly (RH)	Plaque de droite (complet)
8.	517 302 510	Plate Assembly (LH)	Plaque de gauche (complet)
9.	250 000 031	Screw (2)	Vis (2)