

2001



ski-doo
ski-doo

Mini Z

Parts Catalog
Catalogue de pièces

484 400 193

PARTS CATALOG

CATALOGUE DE PIÈCES

2001

MINI Z

◆ WARNING

For user safety, Rotax engines designed for snowmobiles must not be used to power products other than Ski-Doo snowmobiles.

Bombardier Inc. and its subsidiaries denies any responsibility for any usage other than the one prescribed.

Dealers that do not follow this practice may be financially liable should injury occur.

Bombardier Inc. reserves the right at any time to discontinue or change specifications, designs, features, models or equipment without incurring obligation.

◆ AVERTISSEMENT

Pour la sécurité des utilisateurs, les moteurs Rotax conçus pour les motoneiges ne doivent pas être utilisés pour des fins autres que de faire fonctionner les motoneiges Ski-Doo.

Bombardier Inc. et ses filiales se dégagent de toute responsabilité pouvant découler des utilisations autres que celle prescrite.

Les concessionnaires qui ne se conforment pas à cet avis peuvent être tenus responsables financièrement advenant des blessures.

Bombardier Inc. se réserve le droit d'effectuer des changements dans le dessin et les caractéristiques de ses véhicules et/ou d'y effectuer des apports ou des améliorations, cela sans s'engager d'aucune façon à effectuer lesdites opérations sur les véhicules déjà fabriqués.

PARTS CATALOG

The illustrations figuring in this parts catalog show typical construction of the different assemblies and, in all cases, may not reproduce the full detail or exact shape of the parts shown. However, they represent parts which have the same or similar function.

SYMBOLS USED IN THIS CATALOG

- @ In «Quantity» column means «Use as Required».
- Opt In «Quantity» column means «Optional».
- N** In «Numerical» column means «New Parts».
- XXX — Parts marked with «XXX» are not available as spare parts.
- A **bold** description indicates that several parts are included in this item.
- Parts identified with an «P», an «E» or a «C» indicate they are part of the «**P**», «**E**» or «**C**» *Gasket Set*.

Ski-Doo Model
Modèle Ski-Doo

MINI Z

Vehicle Codification
Code du véhicule
CAN / U.S. / Europe

1818

Rotax Engine Type
Type de moteur Rotax

400 101 103

Honda Carburetor
Carburateur Honda

H16100ZK7U51



CATALOGUE DE PIÈCES

Les illustrations contenues dans ce catalogue indiquent la disposition des pièces les unes par rapport aux autres. Il est donc possible qu'elles ne rendent pas compte de la forme exacte de ces pièces ainsi que de leurs détails de fabrication. Ces illustrations ont pour but d'identifier des pièces qui remplissent la même fonction ou une fonction identique.

SYMBOLES UTILISÉS DANS CE CATALOGUE

- @ Dans la colonne «Quantité» signifie «Au besoin».
- Opt Dans la colonne «Quantité» signifie «En option».
- N** Dans la colonne «Numérique» signifie «Nouvelle pièce».
- XXX — Les articles marqués d'un «XXX» ne sont pas disponibles comme pièces de remplacement.
- Une description en caractère **gras** signifie qu'il y a plus d'une pièce dans cet item.
- Les pièces identifiées d'un «P», d'un «E» ou d'un «C» indiquent qu'elles font parties de l'*ensemble de joint d'étanchéité* «**P**», «**E**» ou «**C**» correspondant.

TABLE OF CONTENTS

TABLE DES MATIÈRES

ENGINE	MOTEUR	
Crankcase, Barrel, Crankshaft, Piston	<i>Carter, chemise de cylindre, vilebrequin, piston</i>	A4, A5
Cylinder Head, Camshaft	<i>Culasse, arbre à cames</i>	A6
Rewind Starter	<i>Démarreur à rappel</i>	A7
Engine Support and Muffler	<i>Support moteur et silencieux</i>	A8
COOLING SYSTEM	SYSTÈME DE REFROIDISSEMENT	
Ignition Coil, Cooling System / Fan	<i>Bobine d'allumage, refroidissement / ventilateur</i>	A9
FUEL SYSTEM	SYSTÈME D'ALIMENTATION	
Fuel System	<i>Système d'alimentation</i>	A10, A11
Carburetor	<i>Carburateur</i>	A12
TRANSMISSION	TRANSMISSION	
Brake and Chain Guard	<i>Frein et garde-chaîne</i>	B1
STEERING AND FRONT SUSPENSION	DIRECTION ET SUSPENSION AVANT	
Steering System and Ski	<i>Système de direction et ski</i>	B2, B3
REAR SUSPENSION	SUSPENSION ARRIÈRE	
Drive Axle and Track	<i>Essieu moteur et chenille</i>	B4
Suspension	<i>Suspension</i>	B5, B6
FRAME AND BODY	CHÂSSIS ET CARROSSERIE	
Frame and Body	<i>Chassis et carrosserie</i>	B7
Cab	<i>Capot</i>	B8
Decal	<i>Décalcomanie</i>	B9
ELECTRICAL SYSTEM	SYSTÈME ÉLECTRIQUE	
Electric System	<i>Système électrique</i>	B10
DOCUMENTATIONS	DOCUMENTATIONS	
Numerical Index	<i>Index numérique</i>	B11, B12
New Part	<i>Nouvelles pièces</i>	B12

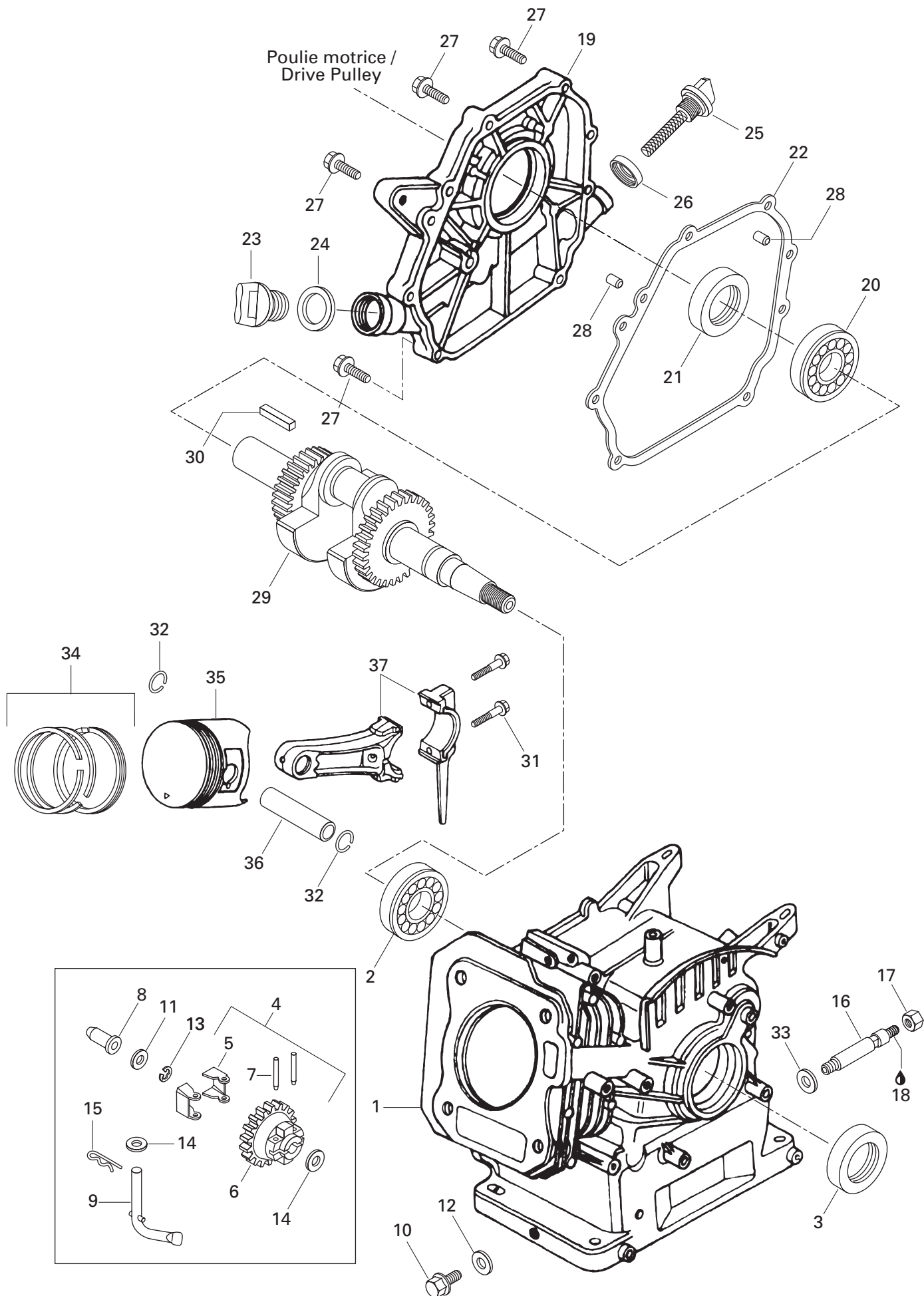

ENGINE/ MOTEUR

CRANKCASE, BARREL, CRANKSHAFT, PISTON/
CARTER, CHEMISE DE CYLINDRE, VILEBREQUIN, PISTON

MINI Z

1→3	H120A0ZH7810	Barrel Ass'y	Chemise de cylindre ass.	1
2	H91001878003	Ball Bearing	Roulement à billes	1
3	H91202ZE6003	Oil Seal	Joint d'étanchéité	1
4→7	H16510ZE1000	Governor Ass'y	Régulateur ass.	1
5	H16511ZE1000	Weight	Poids	2
6	H16512ZE1000	Holder	Support	1
7	H16513ZE1000	Pin	Axe	2
8	H16531ZE1000	Slider	Glissière	1
9	H16541ZE1000	Shaft	Tige	1
10	H90131ZE1000	Drain Plug Bolt	Bouchon boulon	1
11	H90451ZE1000	Thrust Washer 6 mm	Rondelle de butée 6 mm	1
12	H90601ZE1000	Washer	Rondelle	1
13	H90602ZE1000	Clip	Clip	1
14	H9410106700	Washer 6 mm	Rondelle 6 mm	2
15	H9425108000	Hair Pin	Goupille de sureté	1
N 16	512 059 347	Bushing	Douille	1
17	415 104 900	Drain Plug	Bouchon de vidange	1
18	293 800 060	Loctite 243, 10 cc.	Loctite 243, 10 cc.	@
19→21	H11300ZE0640	Crankcase Cover Ass'y	Couvercle de carter ass.	1
20	H91001878003	Ball Bearing	Roulement à billes	1
21	H91203ZE0003	Oil Seal	Joint d'étanchéité	1
22	H11381ZH7800	Packing	Joint	1
23→24	H15600ZE1003	Oil Filler Cap	Bouchon de remplissage	
		(Dipstick)	(réglette de niveau)	1
24	H15625ZE1003	Packing	Joint	1
25→26	H15600ZG4003	Oil Filler Cap	Bouchon de remplissage	1
26	H15625ZE1003	Packing	Joint	1
27	H90015883000	Screw 6 x 28	Vis 6 x 28	7
28	H9430108140	Dowel Pin 8 x 14	Cheville 8 x 14	2
29	H13310ZE0601	Crankshaft	Vilebrequin	1
30	H90745ZE1600	Key	Clavette	1
31	H90001ZE1000	Connecting Rod Bolt	Boulon bielle	2
32	H90551ZE0000	Circlip	Circlip	2
33	414 920 600	Washer	Rondelle	1
34	H13010ZE6013	Ring Set (Standard)	Ens. de segments (standard)	1
	H13011ZE6013	Ring Set (0.25)	Ens. de segments (0.25)	Opt.
	H13012ZE6013	Ring Set (0.50)	Ens. de segments (0.50)	Opt.
	H13013ZE6013	Ring Set (0.75)	Ens. de segments (0.75)	Opt.

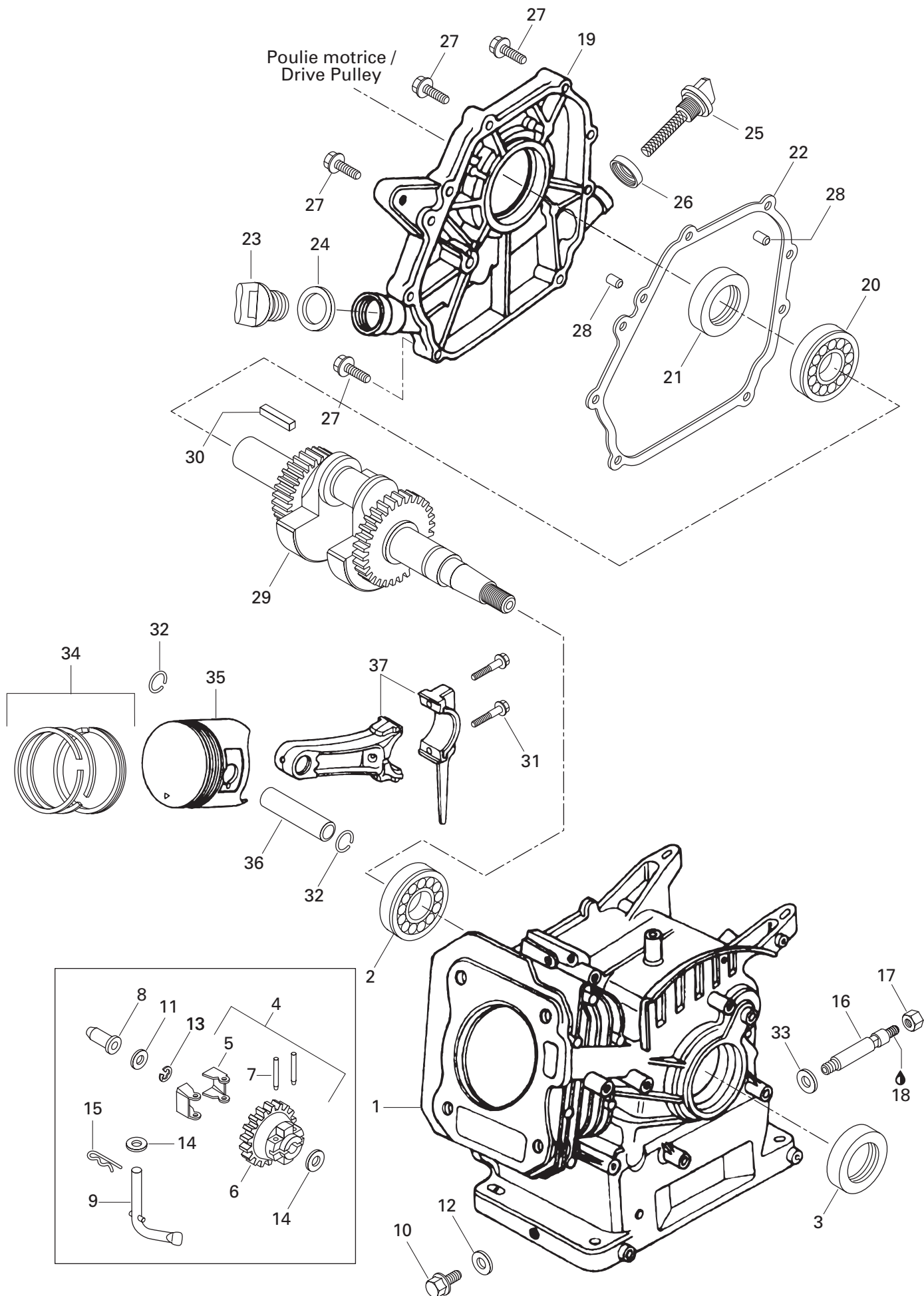

**ENGINE/
MOTEUR**

CRANKCASE, BARREL, CRANKSHAFT, PISTON/
CARTER, CHEMISE DE CYLINDRE, VILEBREQUIN, PISTON

MINI Z

35	H13101ZH7000	Piston (Standard)	Piston (standard)	1
	H13102ZH7000	Piston (0.25)	Piston (0.25)	Opt.
	H13103ZH7000	Piston (0.50)	Piston (0.50)	Opt.
	H13104ZH7000	Piston (0.75)	Piston (0.75)	Opt.
36	H13111ZE0000	Piston Pin	Axe de piston	1
37→38	H13200ZE0000	Rod Repair Kit	Ens. tige réparation	1
	H132A0ZE0000	Rod Repair Kit (Under Size)	Ens. tige réparation	Opt.

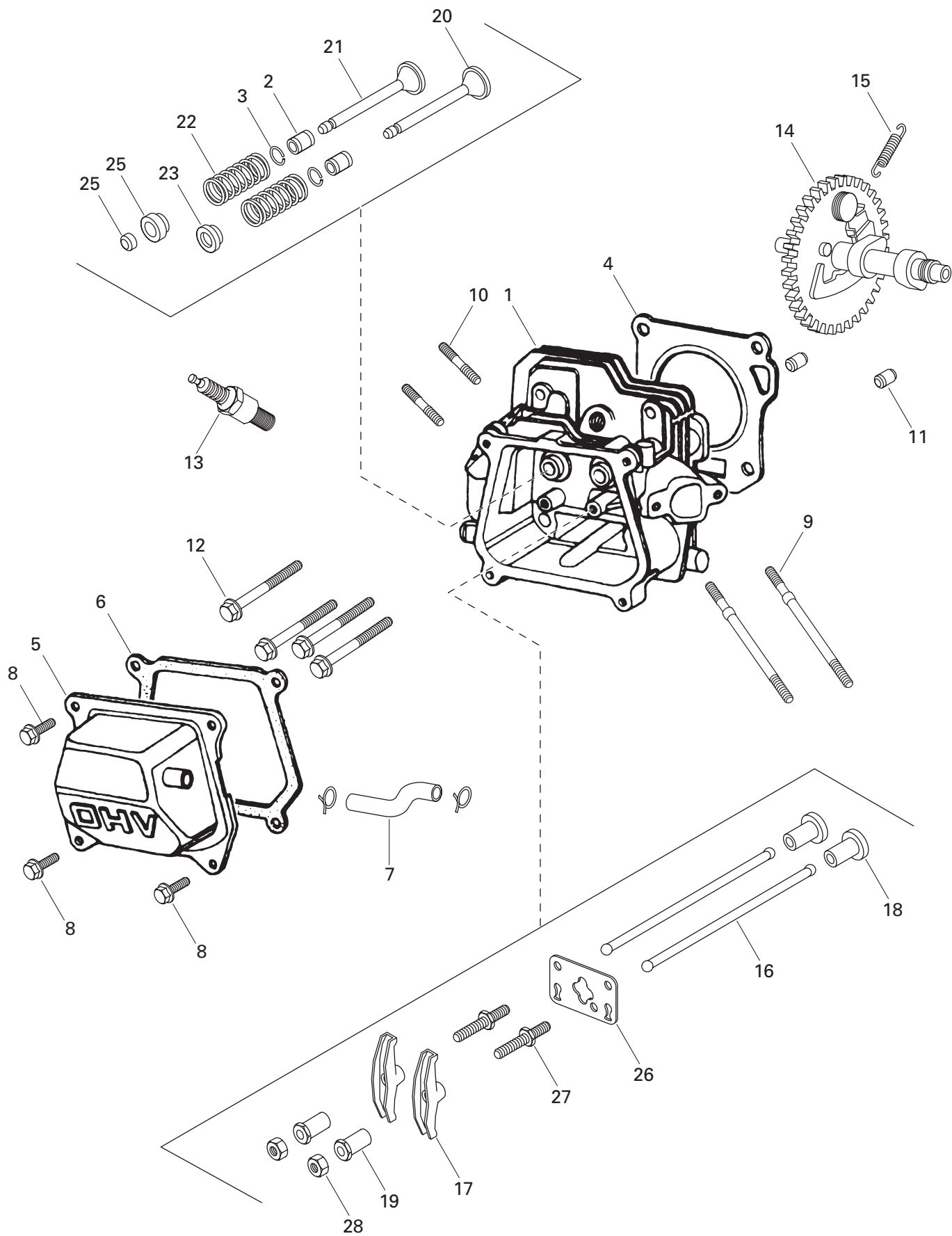

ENGINE/ MOTEUR

CYLINDER HEAD, CAMSHAFT/
CULASSE, ARBRE À CAMES

MINI Z

1→3	H12210ZH7000	Cylinder Head Ass'y	Culasse ass.	1
2	H12204ZE1306	Valve Guide (Intake).....	Guide de soupape (admission)	1
3	H12216ZE5300	Circlip	Circlip	1
4	H12251ZH7800	Gasket	Joint	1
5	H12310ZE1000	Head Cover	Couvercle	1
6	H12391ZE1000	Packing	Joint	1
7	H15721ZH8000	Breather Tube	Tube de reniflard	1
8	H90013883000	Screw	Vis	4
9	H90043ZE1020	Stud	Goujon	2
10	H90047ZE1000	Stud 8 x 32	Goujon 8 x 32	2
11	H9430110160	Dowel Pin 10 x 16	Goupille cylindrique 10 x 16	2
12	H957230805500	Screw 8 x 55.....	Vis 8 x 55	4
13	415 127 694	Spark Plug (NGK BPR6ES)	Bougie d'allumage (NGK BPR6ES)	1
	415 127 693	Spark Plug (NGK BPR5ES)	Bougie d'allumage (NGK BPR5ES)	Opt.
	H9807955855	Spark Plug (Denso W16EPR-U)	Bougie d'allumage (Denso W16EPR-U)	Opt.
	H9807956855	Spark Plug (Denso W20EPR-U)	Bougie d'allumage (Denso W20EPR-U)	Opt.
14→15	H14100ZE0812	Camshaft Ass'y	Arbre à cames ass.	1
15	H14568ZE1000	Spring	Ressort.....	1
16	H14410ZE0010	Push Rod.....	Tige de poussoir	2
17	H14431ZE1000	Valve Rocker Arm	Bras culbuteur.....	2
18	H14441ZE1010	Valve Lifter	Levier soupape	2
19	H14451ZE1013	Rocker Arm Pivot.....	Pivot de culbuteur	2
20	H14711ZF0000	Intake Valve.....	Soupape d'admission.....	1
21	H14721ZF0000	Exhaust Valve	Soupape d'échappement.....	1
22	H14751ZF1000	Valve Spring	Ressort de soupape	2
23	H14771ZE1000	Retainer (Intake).....	Cage (admission).....	1
24	H14773ZE1000	Retainer (Exhaust).....	Cage (échappement).....	1
25	H14781ZE1000	Valve Rotator	Rotateur de soupape	1
26	H14791ZE0010	Plate	Plaque	1
27	H90012ZE0010	Pivot Bolt 8 mm	Boulon de pivot 8 mm.....	2
28	H90206ZE1000	Pivot Adjusting Nut	Écrou de réglage de pivot	2

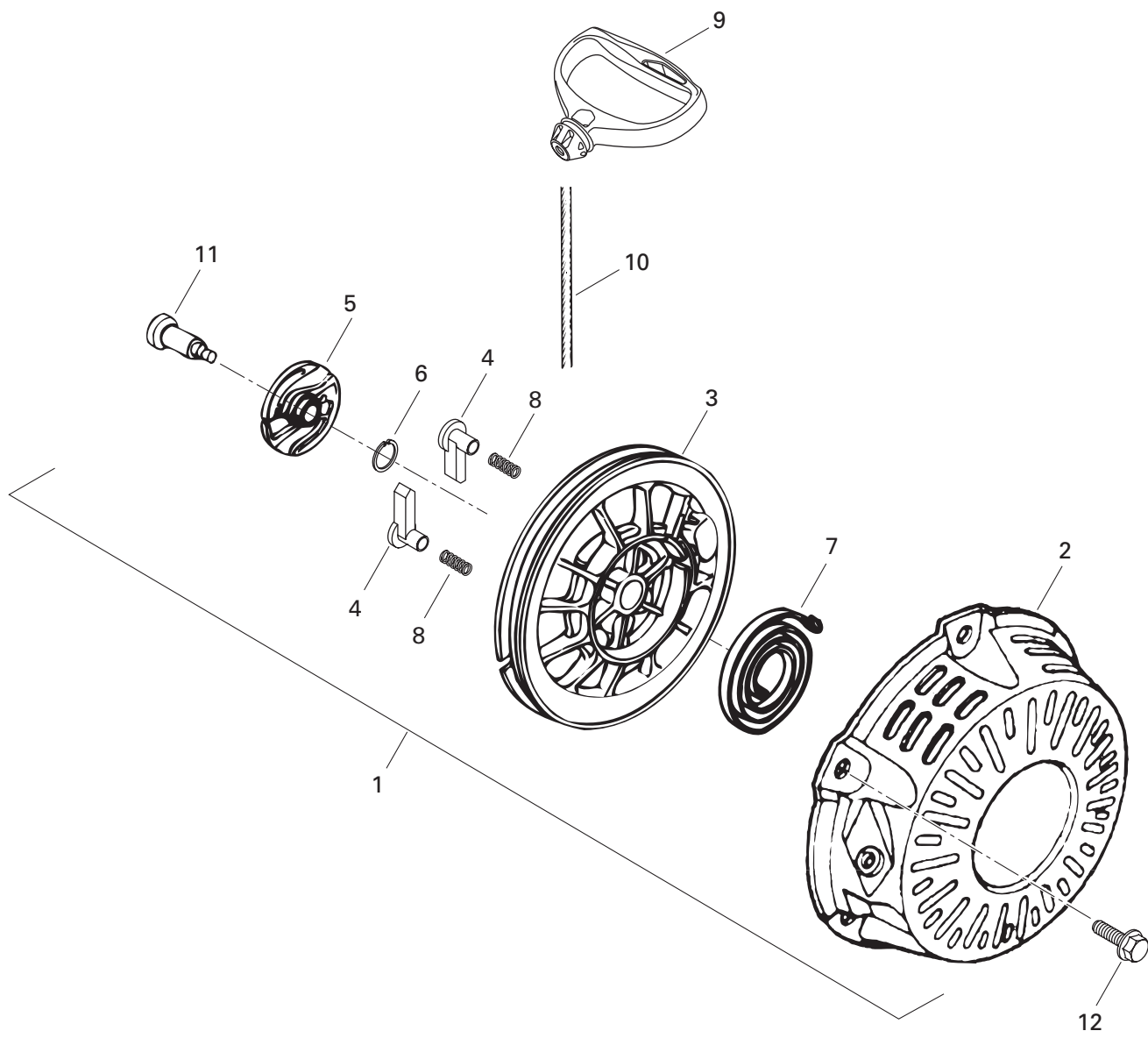

**ENGINE/
MOTEUR**REWIND STARTER/
DÉMARREUR À RAPPEL

MINI Z

1→11	H28400ZH8013ZV	Rewind Starter Ass'y	Démarreur à rappel ass.	1
2	H28410ZH8003ZV	Starter Housing	Boîtier du démarreur	1
3	H28420ZH8013	Rope Sheave	Poulie de démarreur	1
4	H28422ZH8013	Ratchet	Cliquet	2
5	H28433ZH8003	Ratchet Guide	Guide du cliquet	1
6	H28441ZH8003	Friction Spring	Ressort de friction	1
7	H28442ZH8003	Recoil Starter Spring	Ressort de démarreur	1
8	H28443ZH8003	Return Spring	Ressort	2
9	H28461ZH8003	Handle	Poignée	1
10	412 500 100	Starter Rope	Corde de démarreur	@
11	H90003ZH8003	Screw	Vis	1
12	H957010600800	Flanged Bolt 6 x 8	Boulon à épaulement 6 x 8	3

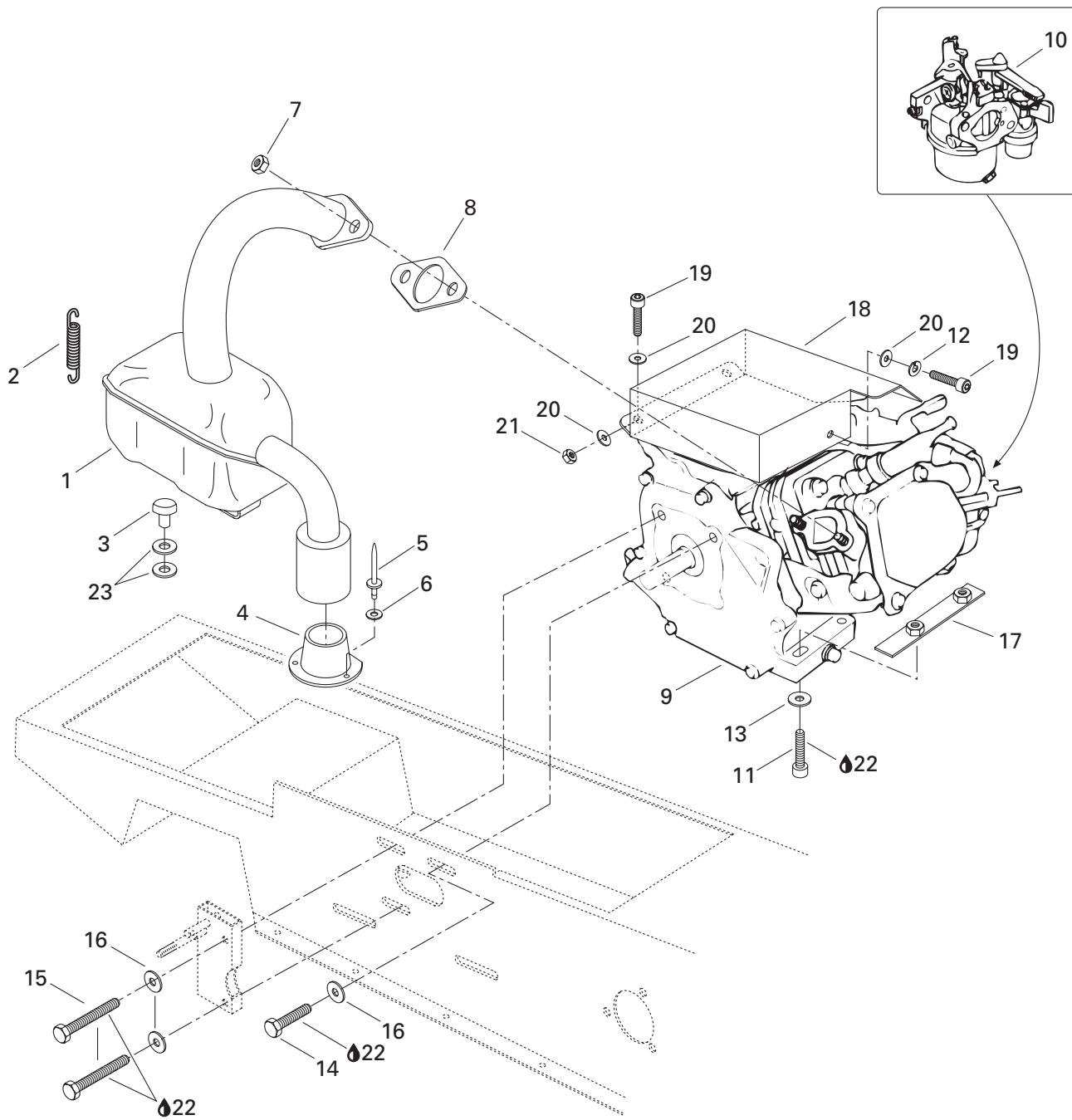

**ENGINE/
MOTEUR**ENGINE SUPPORT AND MUFFLER/
SUPPORT MOTEUR ET SILENCIEUX

MINI Z

1	514 098 700	Muffler	Silencieux	1
2	415 104 800	Spring	Ressort	1
3	570 044 700	Rubber Bumper	Butoir de caoutchouc	1
4	570 028 700	Exhaust Grommet	Rondelle d'échappement	1
5	390 407 200	Pop Rivet	Pop rivet	3
6	234 051 410	Flat Washer 5 mm	Rondelle plate 5 mm	3
7	H94001080000S	Hex. Nut M8	Écrou hex. M8	2
8	H18381ZH8800	Gasket	Joint	1
9	400 101 103	«118» Engine (Yellow)	Moteur «118» (jaune)	1
10	H16100ZK7U51	Carburetor Ass'y	Carburateur ass.	1
11	207 083 544	Hex. Screw M8 x 35	Vis hex. M8 x 35	4
12	234 161 471	Lock Washer 6 mm	Rondelle frein 6 mm	1
13	224 081 201	Flat Washer	Rondelle plate	4
14	— XXX —	Hex. Screw 5/16 x 3/4	Vis hex. 5/16 x 3/4	1
15	— XXX —	Hex. Screw 5/16 x 1 1/4	Vis hex. 5/16 x 1 1/4	2
16	224 081 201	Flat Washer	Rondelle plate	3
17	512 057 400	Stopper Plate	Plaque de butée	2
18	512 059 187	Engine Protector	Protecteur moteur	1
19	207 063 044	Hex. Screw M6 x 30	Vis hex. M6 x 30	3
20	234 061 410	Flat Washer 6 mm	Rondelle plate 6 mm	5
21	232 561 414	Elastic Stop Nut M6	Écrou d'arrêt élastique M6	2
22	293 800 060	Loctite 243, 10 cc.	Loctite 243, 10 cc.	@
23	583 183 400	Washer	Rondelle	2

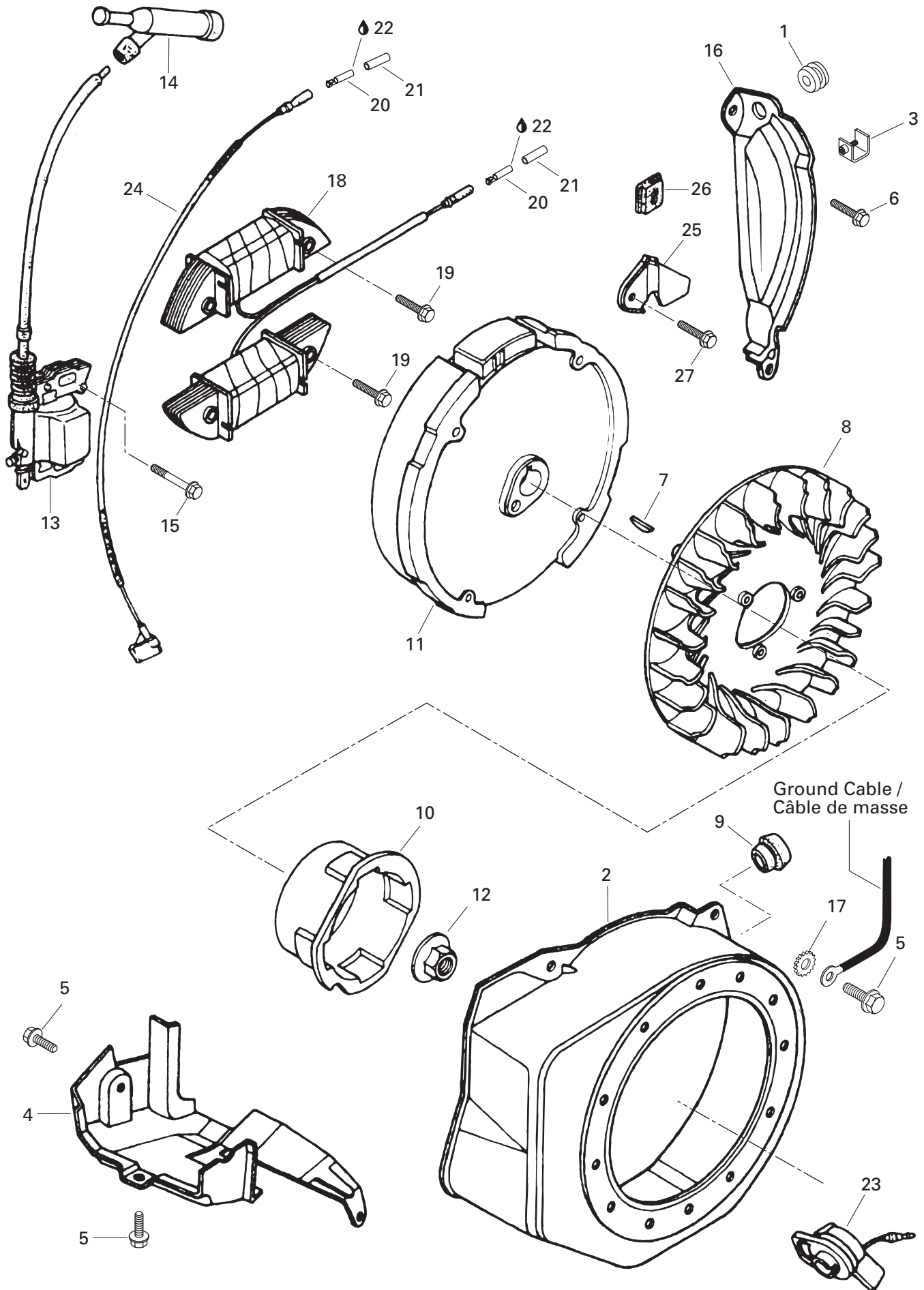

COOLING SYSTEM/ SYSTÈME DE REFROIDISSEMENT

IGNITION COIL, COOLING SYSTEM/FAN/
BOBINE D'ALLUMAGE, REFROIDISSEMENT/VENTILATEUR

MINI Z

1	H11347371300	Grommet	Passe-fil	1
2	H19610ZE0000Z0	Cover	Couvercle	1
3	H90601ZH7013	Clip	Bride	1
4	H19630ZH7000	Shroud	Buse	1
5	H90013883000	Screw	Vis	6
6	H90022888010	Screw	Vis	1
7	H13331357000	Key	Clavette	1
8	H19511ZE0000	Fan	Ventilateur	1
9	H81329567020	Plug	Bouchon	1
10	H28451ZH8003	Starter Pulley	Poulie de démarreur	1
11	— XXX —	Flywheel	Volant	1
12	H90201878003	Nut 14 mm	Écrou 14 mm	1
13	H30500ZE1033	Ignition Coil	Bobine d'allumage	1
14	H30700ZE1013	Cap	Capuchon	1
15	H90121952000	Flanged Bolt 6 x 25	Boulon à épaulement 6 x 25	2
16	H19612ZH7820	Side Plate	Plaque latérale	1
17	234 461 608	Star Washer	Rondelle étoile	1
18	H31510ZK7U50	Lamp Coil Ass'y	Bobine d'éclairage ass.	1
19	H90015883000	Flanged Bolt 6 x 28	Boulon à épaulement 6 x 28	2
20	515 175 451	Female Terminal	Cosse femelle	2
21	278 001 007	Insulated Sheath	Étui thermique	2
22	413 701 700	Dielectric Grease, 3 oz.	Graisse diélectrique, 3 oz.	@
23	H36100ZH7003	Switch Ass'y	Interrupteur	1
24	H36101ZK7U50	Cord Stop Switch	Câblage	1
25	H31511ZE1000	Clamper	Support	1
26	H31512ZE1000	Grommet	Passe-fils	1
27	H90019883000	Screw M5 x 10	Vis M5 x 10	1

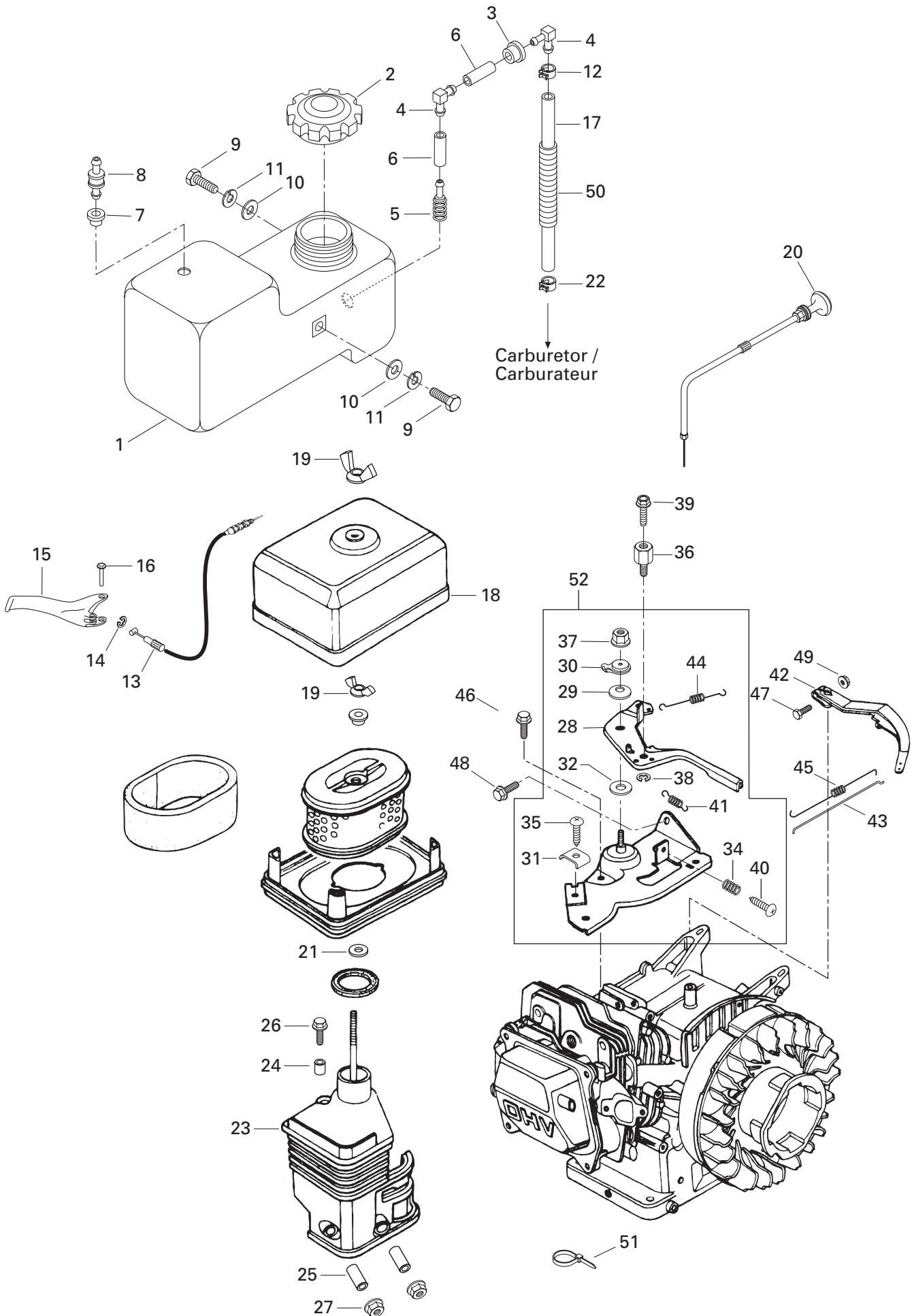

FUEL SYSTEM/ SYSTÈME D'ALIMENTATION

FUEL SYSTEM/
SYSTÈME D'ALIMENTATION

MINI Z

1	571 009 800	Fuel Tank	Réservoir à essence	1
2	572 039 600	Cap	Bouchon	1
3	570 045 500	Grommet	Passe-fils	1
4	414 580 600	Male Connector	Raccord mâle	2
5	414 865 700	Fuel Filter	Crépine	1
6	415 080 200	Line	Conduit	@
7	570 027 700	Grommet	Passe-fils	1
8	275 500 398	Check Valve	Soupape de retenue	1
9	207 161 044	Hex. Screw M6 x 10	Vis hex. M6 x 10	3
10	224 061 121	Flat Washer	Rondelle plate	3
11	224 761 110	Lock Washer 6 mm	Rondelle frein 6 mm	3
12	414 554 800	Spring Clamp	Bride à ressort	1
13	415 087 400	Throttle Cable	Câble d'accélérateur	1
14	414 274 500	Circlip	Circlip	1
15	506 151 227	Throttle Handle	Manette d'accélérateur	1
16	390 502 000	Tubular Rivet	Rivet tubulaire	1
17	513 032 924	Line	Conduit	1
18	H17230ZE0820	Intake Cover	Couvercle d'admission	1
19	H90325044000	Wing Nut	Écrou papillon	1
20	415 108 600	Choke Cable	Câble étrangleur	1
21	234 461 608	Lock Washer	Rondelle frein	1
22	415 127 453	Spring Clamp	Bride à ressort	1
23→25	H17410ZE0030	Air Cleaner Elbow Ass'y	Coude du filtre à air ass.	1
24	H17239ZE1000	Collar B	Collet B	1
25	H17238ZE0010	Collar	Collet	2
26	H957010602000	Flanged Bolt 6 x 20	Boulon à épaulement 6 x 20	1
27	H9405006080	Flanged Nut 6 mm	Écrou à épaulement 6 mm	2
28→40	H16500ZH7810	Control Ass'y	Commande ass.	1
28	H16571ZH7000	Control Lever	Levier de commande	1
29	H16574ZE1000	Spring Lever	Ressort	1
30	H16575ZH8000	Washer	Rondelle	1
31	H16576891000	Cable Holder	Porte câble	1
32	H16578ZE1000	Spacer	Entretoise	1
33	H16580ZH7810	Base	Base	1
34	H16584883300	Spring	Ressort	1
35	H93500050160B	Pan Screw 5 x 16	Vis à tête cylindrique 5 x 16	1
36	H16594883010	Cable Holder	Porte câble	1
37	H90114SA0000	Nut	Écrou	1
38	H90605230000	Circlip	Circlip	1
39	H93500040060H	Screw	Vis	1

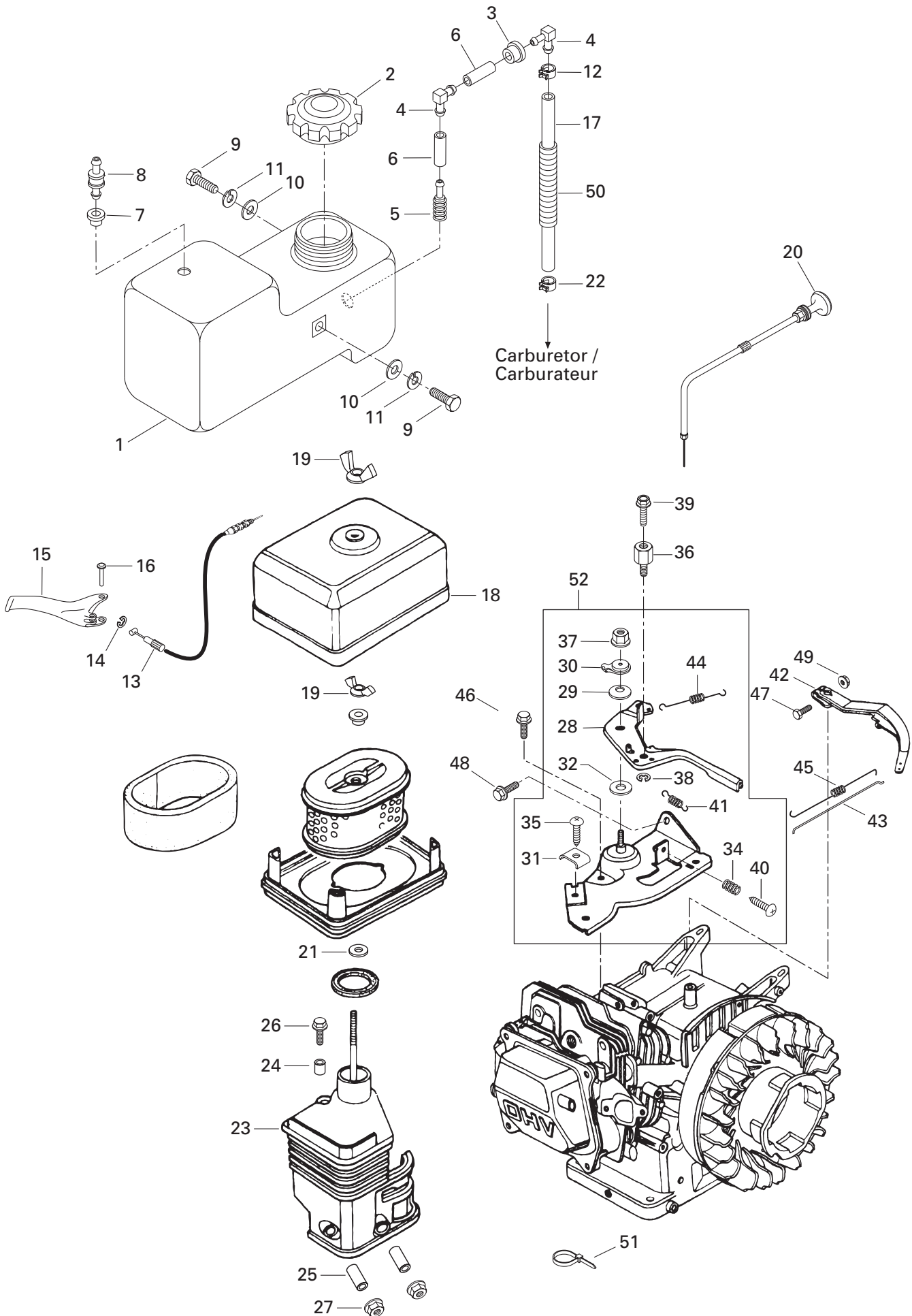

FUEL SYSTEM/ SYSTÈME D'ALIMENTATION

FUEL SYSTEM/
SYSTÈME D'ALIMENTATION

MINI Z

40	H93500050250H	Screw	Vis	1
41	512 059 048	Release Spring	Ressort de rappel	1
42	H16551ZE1010	Governor Arm	Bras	1
43	H16555ZE0000	Governor Rod	Tige	1
44	H16561ZE0020	Governor Spring	Ressort	1
45	H16562ZE0020	Throttle Return Spring	Ressort	1
46	H90013883000	Screw	Vis	1
47	H90015ZE5010	Bolt	Boulon	1
48	H90022888010	Flanged Bolt 6 x 20	Boulon à épaulement 6 x 20	1
49	H9405006080	Flanged Nut 6 mm	Écrou à épaulement 6 mm	1
50	414 612 400	Housing	Gaine	@
51	293 750 002	Tie Rap 130 mm	Attache 130 mm	1
52	H16500ZK7U50	Control Ass'y	Commande ass.	1

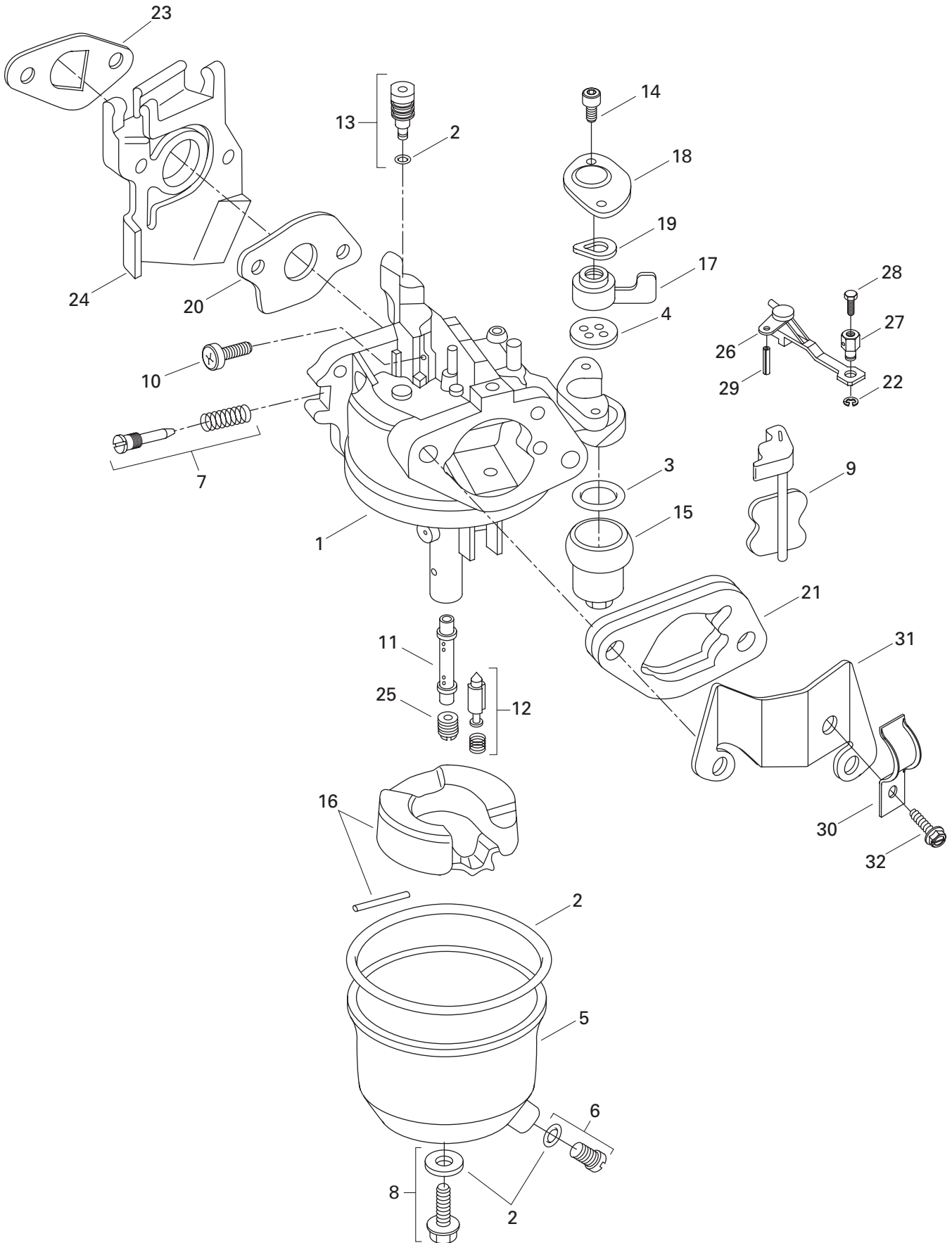

FUEL SYSTEM/ SYSTÈME D'ALIMENTATION

CARBURETOR/
CARBURATEUR

MINI Z

1→19	H16100ZK7U51	Carburetor Ass'y	Carburateur ass.	1
2→4	H16010ZE1812	Carburator Gasket Set	Ens. joint d'étanchéité carburateur	1
3	H16955283000	Packard	Joint	1
4	H16957ZE1812	Packing	Joint	1
5→6	H16015ZE1811	Chamber	Chambre	1
6	H16024ZE1811	Drain Bolt	Vis	1
7	H16016ZE0005	Drain Screw	Vis	1
8	H16028ZE0005	Screw	Vis	1
9	H16044ZE0005	Choke	Étrangleur	1
10	H16124ZE0005	Screw	Vis	1
11	H16166ZH7W50	Nozzle	Gicleur	1
12	H16011ZE0005	Valve Set	Ensemble soupape	1
13	H99204ZE00350	Pilot Jet 35	Gicleur 35	1
14	H93500030080G	Screw	Vis	2
15	H16967ZE0811	Cup	Cuvette	1
16	H16013ZE0005	Float	Flotteur	1
17	H16953ZE1406	Lever	Levier	1
18	H16954ZE1812	Lever Plate	Plaque du levier	1
19	H16956ZE1811	Spring	Ressort	1
20	H16221ZH8801	Packing	Joint	1
21	H16220ZE1020	Spacer	Cale	1
22	H90605230000	Circlip	Circlip	1
23	H16212ZH7800	Packing	Joint	1
24	H16211ZE0000	Insulator	Isolateur	1
25	H99101ZH80620	Main Jet 62	Gicleur 62	1
	H99101ZH70650	Main Jet 65	Gicleur 65	Opt
	H99101ZH70680	Main Jet 68	Gicleur 68	Opt
26	H16610ZE1810	Lever	Levier	1
27	H16617890010	Holder	Teneur	1
28	H93500040080A	Hex. Screw M4 x 8	Vis hex. M4 x 8	1
29	H9430520122	Spring Pin	Goupille ressort	1
30	H16582883300	Holder	Bride	1
31	H16598ZE1000	Stay	Support	1
32	H93500050080A	Screw	Vis	1

**Chain Guard
Garde-chaîne**

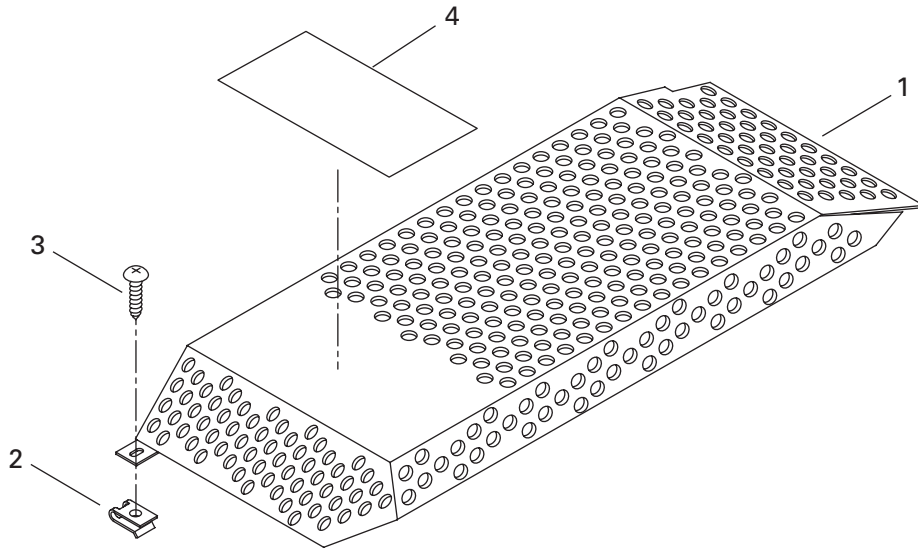

**Brake
Frein**

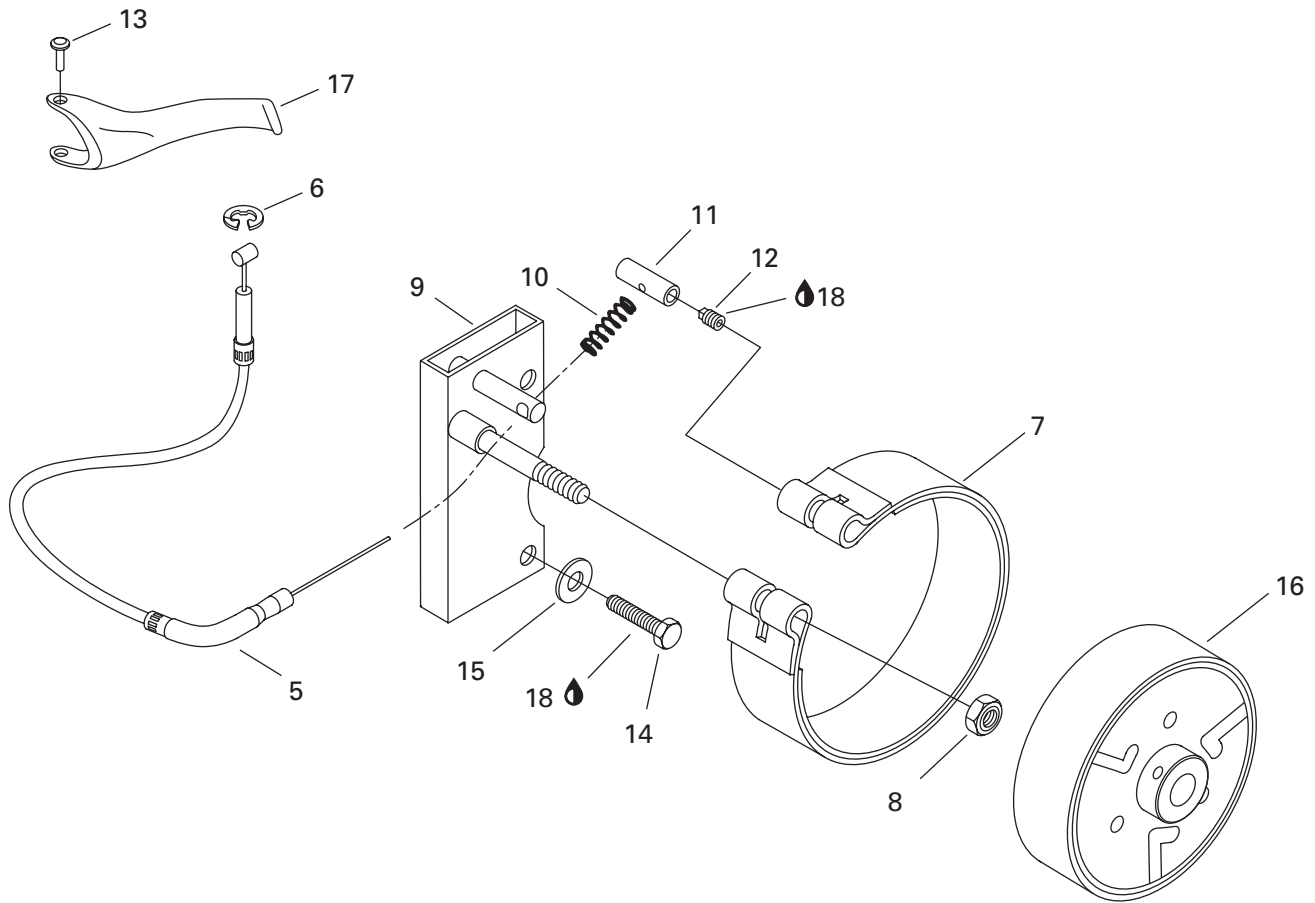

TRANSMISSION/ TRANSMISSION

BRAKE AND CHAIN GUARD/
FREIN ET GARDE-CHAÎNE

MINI Z

1	504 149 600	Chain Guard	Garde-chaîne	1
2	417 300 005	Nut Spring	Écrou ressort	3
3	417 300 006	Tapping Screw 4.8 x 16	Vis autotaraudeuse 4.8 x 16	3
4	516 000 131	Warning Decal (Pulley Guard)	Décalque d'avertissement (garde poulie)	1
N 5	507 032 289	Brake Cable	Câble de frein	1
6	414 274 500	Circlip	Circlip	1
7	507 031 600	Shoe Ass'y	Sabot ass.	1
8	232 581 414	Elastic Stop Nut M8	Écrou d'arrêt élastique M8	1
N 9	507 032 297	Brake Support	Support de frein	1
10	507 032 229	Release Spring	Ressort rappel	1
11→12	415 086 300	Cable Lock	Barrure de câble	1
12	303 115 900	Socket Set Screw	Vis de pression	1
13	390 502 000	Tubular Rivet	Rivet tubulaire	1
14	— XXX —	Hex. Screw 5/16 x 1 1/4	Vis hex. 5/16 x 1 1/4	2
15	224 081 201	Flat Washer	Rondelle plate	2
16	417 217 200	Drive Pulley Ass'y	Poulie motrice ass.	1
17	506 151 225	Brake Handle	Manette de frein	1
18	293 800 060	Loctite 243, 10 cc.	Loctite 243, 10 cc.	@

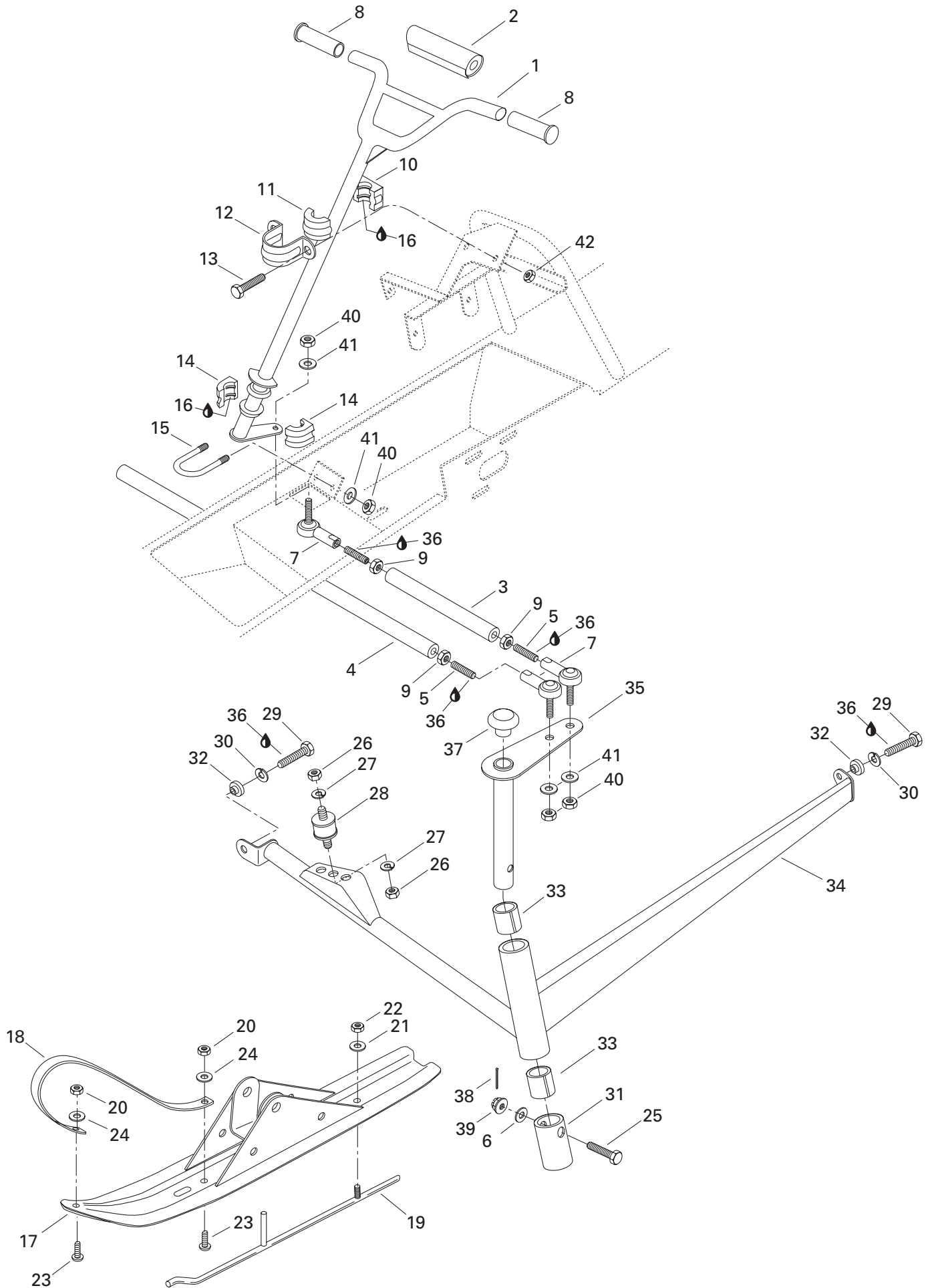

STEERING AND FRONT SUSPENSION/ DIRECTION ET SUSPENSION AVANT

STEERING SYSTEM AND SKI/
SYSTÈME DE DIRECTION ET SKI

MINI Z

N 1	506 151 419	Handle Bar	Guidon	1
2	572 103 400	Steering Padding	Coussinet de sécurité	1
3	506 151 186	Tie Rod (Short)	Barre d'accouplement (court)	1
4	506 151 187	Tie Rod (Long)	Barre d'accouplement (longue)	1
5	206 285 044	Socket Set Screw M8 x 50	Vis pression M8 x 50	4
6	234 001 410	Flat Washer 10 mm	Rondelle plate 10 mm	2
7	415 108 500	Ball Joint	Joint rotule	4
8	572 064 100	Handle Grip	Gaine de poignée	2
9	232 081 414	Nut M8	Écrou M8	4
10	572 064 400	Bushing	Douille	1
11	572 064 500	Bushing	Douille	1
12	517 126 200	Retaining Support	Support de retenue	1
13	207 182 044	Hex. Screw M8 x 20	Vis hex. M8 x 20	2
14	572 067 100	Half Bushing	Demie-douille	2
15	506 060 600	U-Clamp	Bride en U	1
16	413 711 500	Synthetic Grease	Graisse synthétique	@
17→24	505 068 300	Ski Ass'y	Ski ass.	2
18	572 099 500	Handle	Poignée	2
19	505 068 400	Runner	Lisse	2
20	232 561 414	Elastic Stop Nut M6	Écrou d'arrêt élastique M6	4
21	234 081 410	Flat Washer 8 mm	Rondelle plate 8 mm	2
22	232 581 414	Elastic Stop Nut M8	Écrou d'arrêt élastique M8	2
23	208 562 560	Screw M6 x 25	Vis M6 x 25	2
24	224 061 201	Flat Washer	Rondelle plate	4
25	505 070 178	Bolt M10 x 60	Boulon M10 x 60	2
26	232 006 414	Nut M10	Écrou M10	4
27	234 100 602	Lock Washer 10 mm	Rondelle frein 10 mm	4
28	570 128 800	Rubber Mount	Tampon d'ancrage	2
29	207 082 544	Hex. Screw M8 x 25	Vis hex. M8 x 25	4
30	234 181 401	Lock Washer 8 mm	Rondelle frein 8 mm	4
31	505 070 457	Spacer	Espaceur	2
32	503 177 000	Double Spacer	Espaceur double	4
33	415 087 300	Cushion	Coussinet	4
N 34	506 151 421	R.H. Swing Arm	Bras oscillant DR	1
N	506 151 422	L.H. Swing Arm	Bras oscillant GA	1
35	505 070 456	R.H. Ski Leg	Jambe de ski DR	1
	505 070 459	L.H. Ski Leg	Jambe de ski GA	1
36	293 800 060	Loctite 243, 10 cc.	Loctite 243, 10 cc.	@
37	572 079 100	Cap	Bouchon	2
38	371 801 000	Cotter Pin	Goupille fendue	2

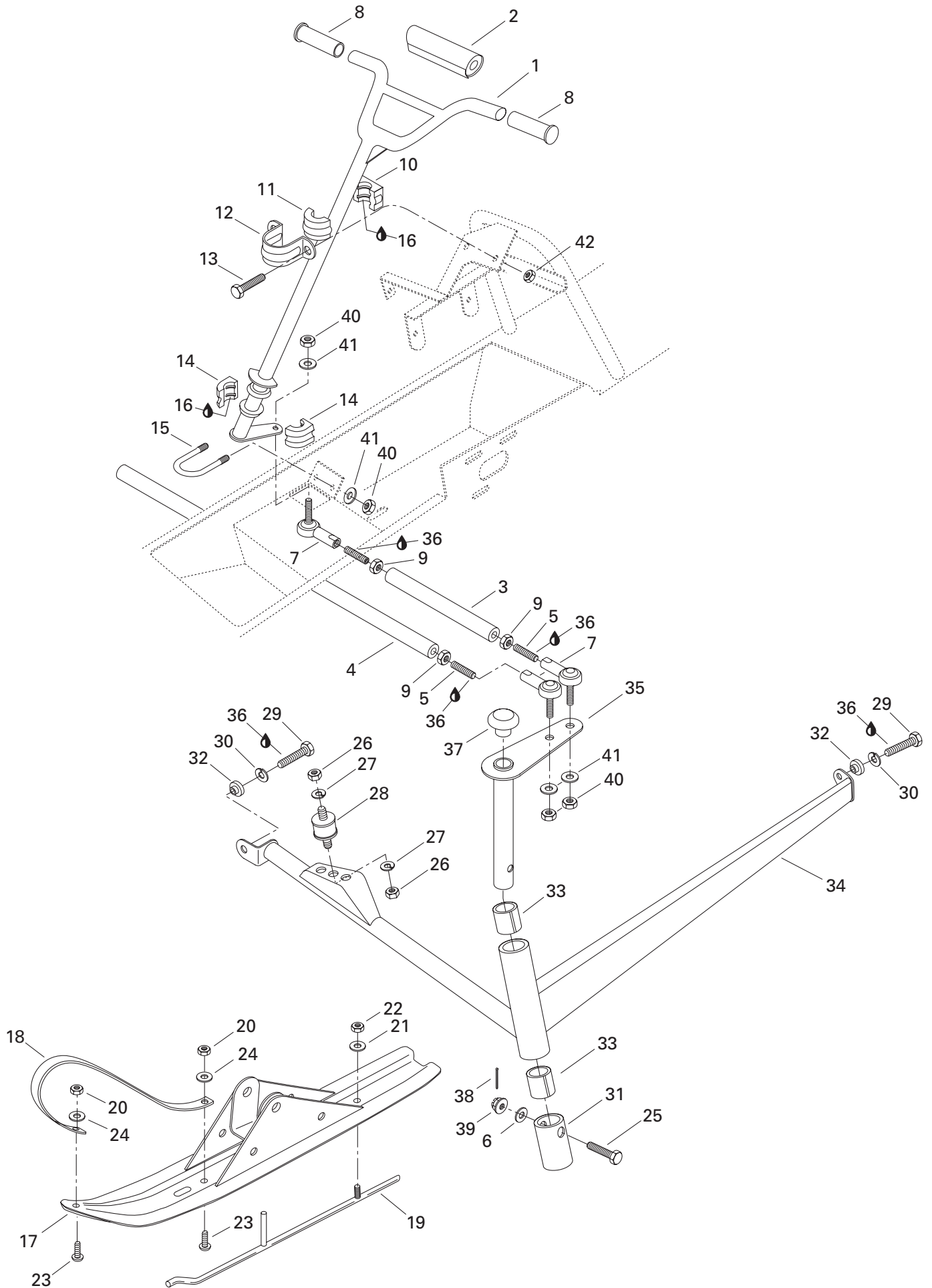

**STEERING AND FRONT SUSPENSION/
DIRECTION ET SUSPENSION AVANT**

STEERING SYSTEM AND SKI/
SYSTÈME DE DIRECTION ET SKI

MINI Z

39	232 201 414	Castellated Nut M10	Écrou à crénaux M10	2
40	232 581 414	Elastic Stop Nut M8	Écrou d'arrêt élastique M8	6
41	234 081 410	Flat Washer 8 mm	Rondelle plate 8 mm	6
42	233 281 414	Nut Flanged Elastic M8	Écrou d'arrêt élastique	2

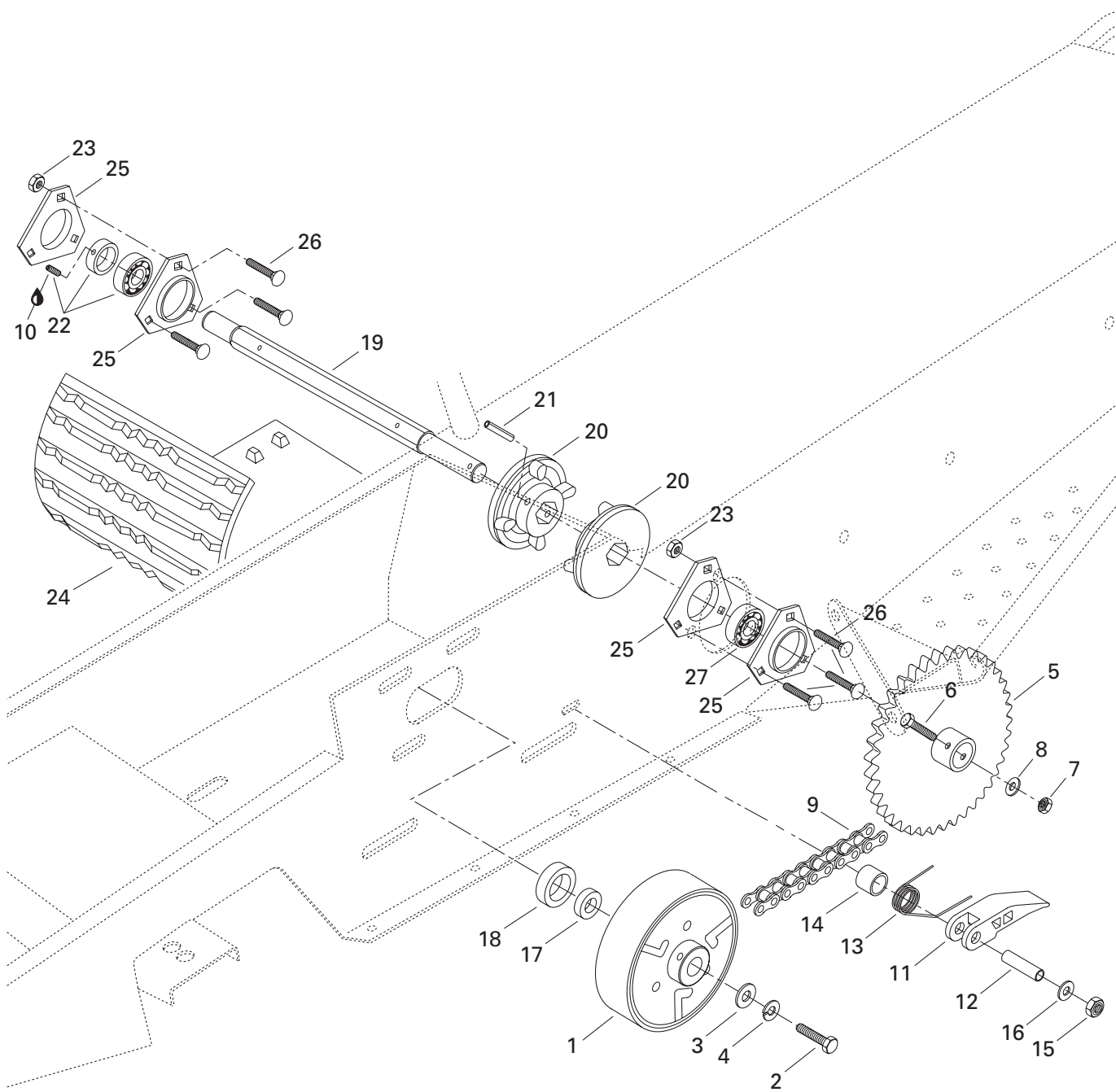

REAR SUSPENSION/ SUSPENSION ARRIÈRE

DRIVE AXLE AND TRACK/
ESSIEU MOTEUR ET CHENILLE

MINI Z

1	417 217 200	Drive Pulley Ass'y.	Poulie motrice ass.	1
2	309 808 900	Hex. Screw 5/16-24	Vis hex 5/16-24.....	1
3	234 082 410	Flat Washer 8 mm	Rondelle plate 8 mm	1
4	234 181 401	Lock Washer 8 mm	Rondelle frein 8 mm	1
5	504 149 500	Sprocket (48 Tooth-Large).....	Pignon (48 dents-large)	1
6	417 126 304	Hex. Screw M8 x 60	Vis hex. M8 x 60	1
7	232 581 414	Elastic Stop Nut M8	Écrou d'arrêt élastique M8	1
8	234 081 410	Flat Washer 8 mm	Rondelle plate 8 mm	1
9	412 107 500	Chain	Chaîne	1
10	293 800 060	Loctite 243, 10 cc.	Loctite 243, 10 cc.	@
11	572 041 600	Chain Tensioner.....	Tendeur de chaîne.....	1
12	504 051 600	Spacer	Entretoise	1
13	415 123 000	Spring	Ressort.....	1
14	504 018 200	Spacer	Entretoise	1
15	232 561 414	Elastic Stop Nut M6	Écrou d'arrêt élastique M6	1
16	224 061 121	Flat Washer	Rondelle plate.....	1
17	504 150 500	Extension	Rallonge	1
18	504 150 600	Spacer	Espaceur.....	1
N 19	504 152 025	Drive Axle.....	Arbre d'entraînement	1
20	504 151 794	4 Tooth Sprocket	Barbotin 4 dents	2
21	211 400 016	Rolled Pin M6 x 40.....	Goupille ressort M6 x 40	2
N 22	504 152 022	Ball Bearing	Roulement à billes	1
23	232 581 414	Elastic Stop Nut M8	Écrou d'arrêt élastique M8	6
24	570 211 900	Track	Chenille	1
25	501 025 000	Flange	Flasque	4
26	207 781 644	Carriage Bolt M8 x 16	Boulon de carrosserie M8 x 16	6
N 27	504 152 029	Ball Bearing	Roulement à billes	1

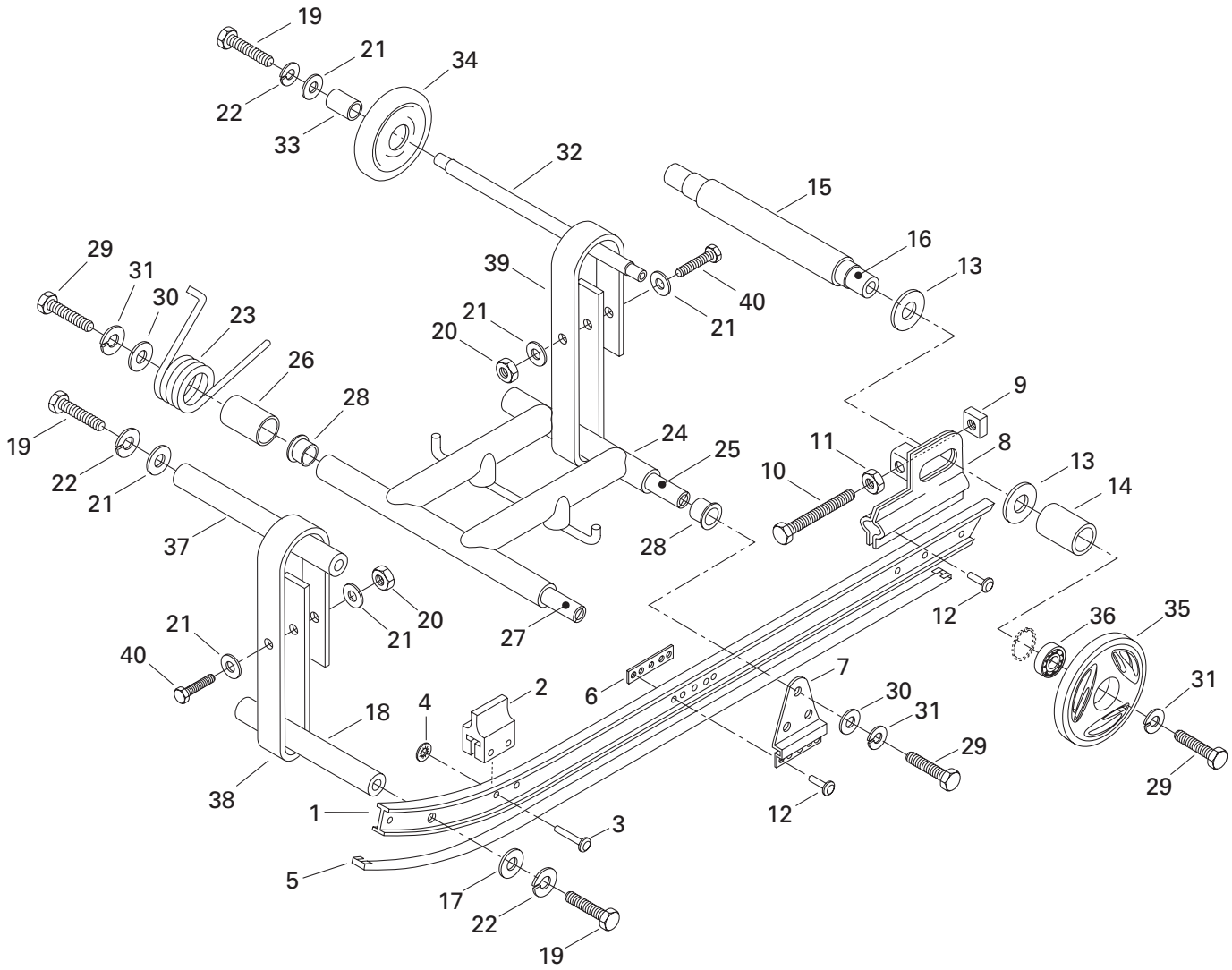

REAR SUSPENSION/ SUSPENSION ARRIÈRE

SUSPENSION/
SUSPENSION

MINI Z

1	503 176 800	Runner	Rail usiné	2
2	570 047 900	Front Rubber Stopper	Butée de caoutchouc avant	2
3	390 004 800	Rivet	Rivet	4
4	389 804 300	Push Nut	Contre-écrou	4
5	415 104 100	Metallic Stripe	Bande métallique	2
6	503 188 900	Spacer	Espaceur	2
7	503 149 800	Front Arm Support	Support du bras avant	2
8→9	503 161 500	L.H. Adjustment Plate	Plaque d'ajustement GA	1
	503 161 400	R.H. Adjustment Plate	Plaque d'ajustement DR	1
9	232 802 400	Square Nut M10	Écrou carré M10	2
10	207 107 544	Hex. Screw M10 x 75	Vis hex. M10 x 75	2
11	232 006 414	Hex. Nut M10	Écrou hex. M10	2
12	390 906 200	Rivet	Rivet	16
13	504 108 200	Shim	Cale épaisseur	4
14	503 177 800	Spacer	Espaceur	2
15	503 178 000	Spacer	Entretoise	1
16	503 178 100	Rear Axle	Essieu arrière	1
17	503 183 300	Washer	Rondelle	2
18	503 177 200	Front Axle	Essieu avant	1
19	207 182 044	Hex. Screw M8 x 20	Vis hex. M8 x 20	6
20	232 581 414	Elastic Stop Nut M8	Écrou d'arrêt élastique M8	2
21	234 082 410	Flat Washer 8 mm	Rondelle plate 8 mm	8
22	234 180 411	Lock Washer 8 mm	Rondelle frein 8 mm	6
23	414 880 400	R.H. Spring	Ressort DR	1
	414 880 500	L.H. Spring	Ressort GA	1
24	503 177 700	Front Arm	Bras avant	1
25	503 177 300	Lower Center Shaft	Essieu central inférieur	1
26	572 110 500	Bushing	Douille	2
27	503 178 400	Upper Center Shaft	Essieu central supérieur	1
28	415 108 000	Cushion	Coussinet	4
29	207 102 544	Hex. Screw M10 x 25	Vis hex. M10 x 25	6
30	224 002 251	Flat Washer	Rondelle plate	4
31	224 701 188	Lock Washer 10 mm	Rondelle frein 10 mm	6
32	503 178 200	Rear Axle	Essieu arrière	1
33	503 177 400	Spacer	Entretoise	2
34	570 067 300	Idle Wheel	Roue de support	2
35→36	572 097 612	Wheel 135	Roue 135	2
36	405 404 500	Ball Bearing 6205	Roulement à billes 6205	2
37	506 147 600	Retainer Axle	Axe de retenue	1
38	570 068 700	Stopper Strap	Courroie d'arrêt	1

**REAR SUSPENSION/
SUSPENSION ARRIÈRE**

SUSPENSION/
SUSPENSION

MINI Z

39	570 069 200	Rear Stopper Strap	Courroie d'arrêt arrière	1
40	207 183 044	Hex. Screw M8 x 30	Vis hex. M8 x 30	2

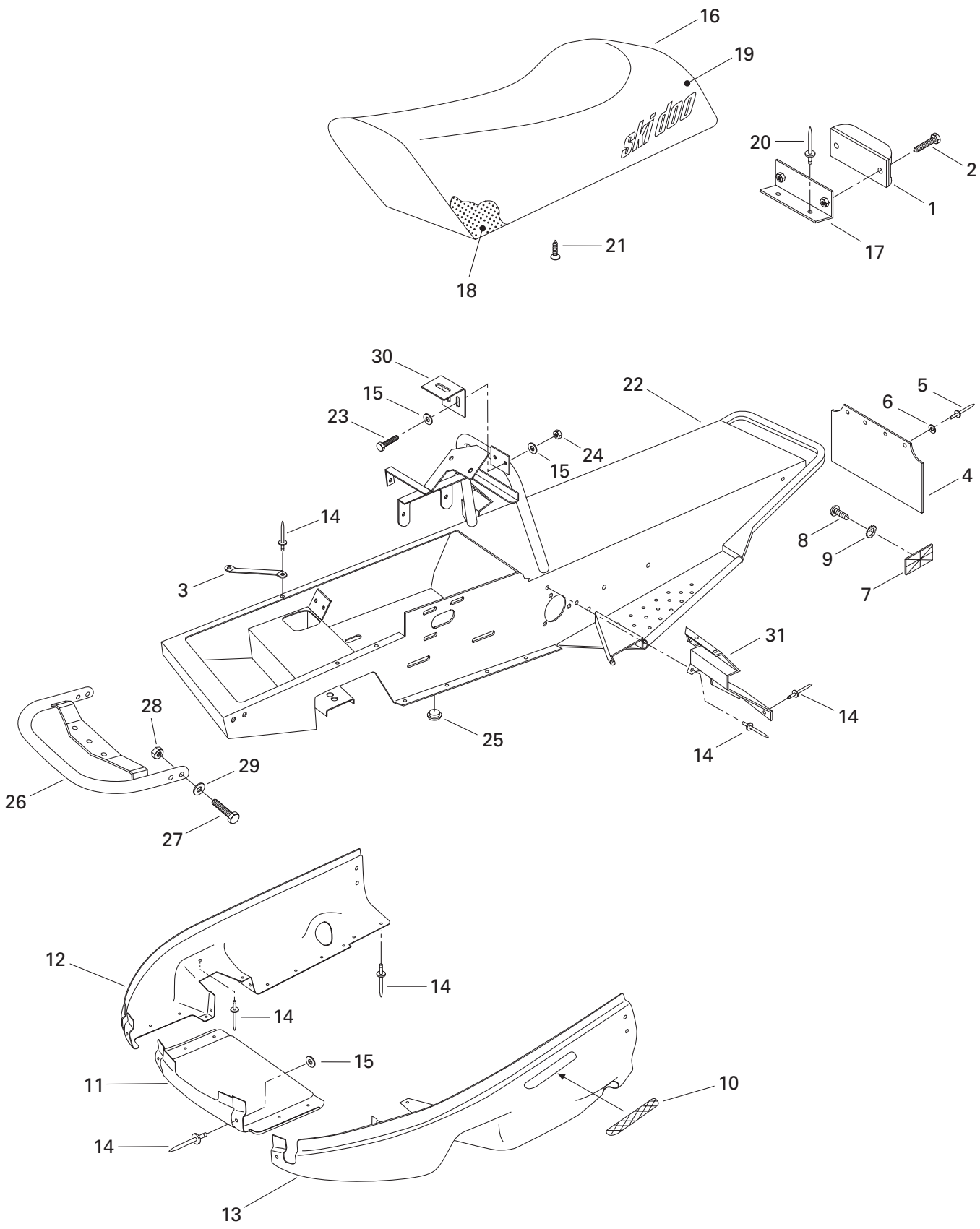

FRAME AND BODY/ CHÂSSIS ET CARROSSERIE

FRAME AND BODY/
CHÂSSIS ET CARROSSERIE

MINI Z

1	415 088 700	Tail Lamp Ass'y	Feu arrière ass.	1
2	207 151 244	Screw M5 x 12	Vis M5 x 12	2
3	502 006 505	Bottom Pan Support	Support de coque	2
4	572 099 800	Snow Guard	Garde-neige	1
5	390 409 600	Pop Rivet (Black)	Pop rivet (noir)	4
6	414 806 800	Flat Washer	Rondelle plate	4
7	414 510 100	Reflector (Red)	Réflecteur (rouge)	2
8	208 651 041	Screw M5 x 10	Vis M5 x 10	2
9	234 451 418	Serrated Lock Washer 5 mm	Rondelle chevauchante ext. 5 mm	2
10	415 064 400	R.H. Reflector	Réflecteur DR	1
	415 064 401	L.H. Reflector	Réflecteur GA	1
11	571 009 500	Nose (Yellow)	Nez (jaune)	1
12	502 006 538	R.H. Bottom Pan (Yellow)	Coque DR (jaune)	1
13	502 006 539	L.H. Bottom Pan (Yellow)	Coque GA (jaune)	1
14	390 910 200	Pop Rivet (Yellow)	Pop rivet (jaune)	48
15	234 051 410	Flat Washer 5 mm	Rondelle plate 5 mm	10
16	— XXX —	Seat Ass'y	Siège ass.	1
17	415 088 400	Tail Lamp Housing	Boîtier du feu arrière	1
18	415 088 302	Foam Seat	Mousse de siège	1
N 19	510 003 910	Seat Cover	Housse de siège	1
20	390 906 800	Pop Rivet	Pop rivet	2
21	369 903 000	Wood Tapping Screw	Vis à bois	4
22	518 321 943	Frame Ass'y	Châssis ass.	1
23	207 151 414	Hex. Screw M5 x 14	Vis hex. M5 x 14	2
24	232 551 414	Elastic Stop Nut M5	Écrou d'arrêt élastique M5	2
25	414 404 800	Plug	Bouchon	4
26	518 320 400	Bumper	Pare-choc	1
27	207 063 044	Hex. Screw M6 x 30	Vis hex. M6 x 30	4
28	232 561 414	Elastic Stop Nut M6	Écrou d'arrêt élastique M6	4
29	234 061 410	Flat Washer 6 mm	Rondelle plate 6 mm	4
30	518 321 300	Adjustable Plate	Plaque d'ajustement	1
31	518 321 950	R.H. Footrest	Repose-pied DR	1
	518 321 952	L.H. Footrest	Repose-pied GA	1

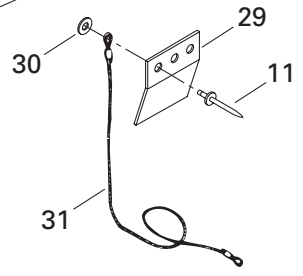
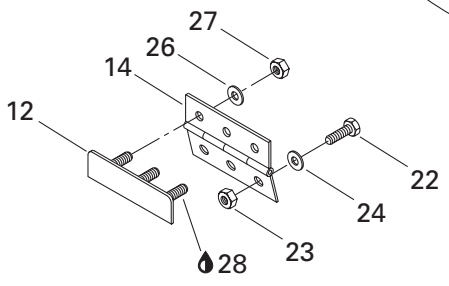
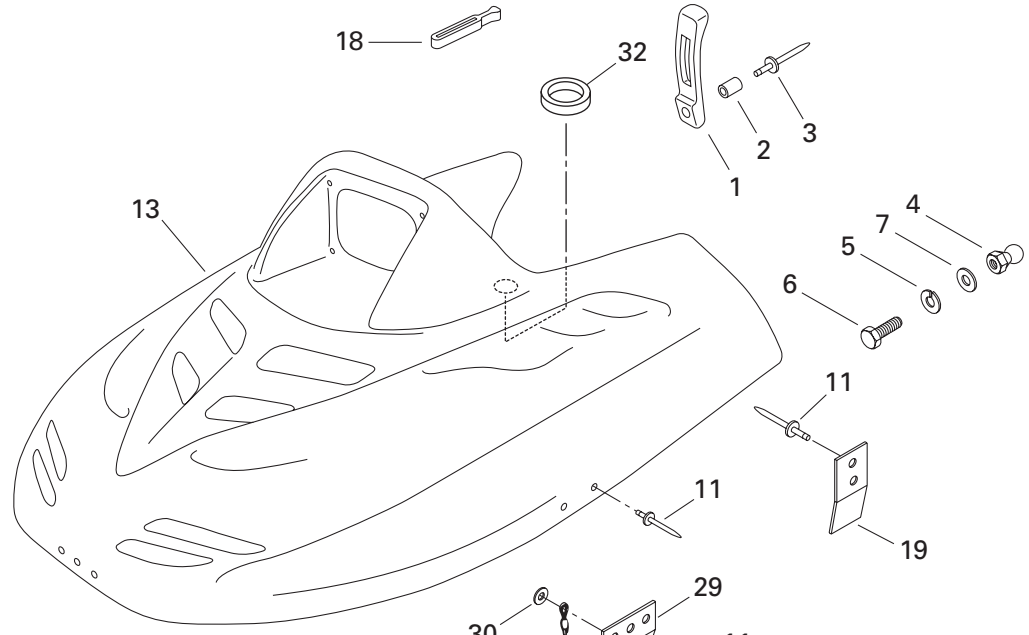
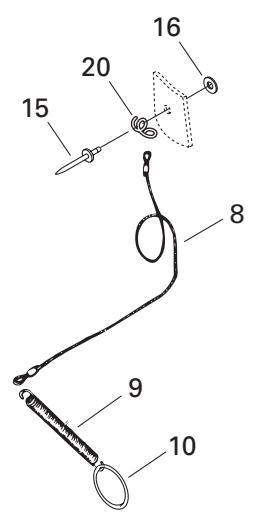
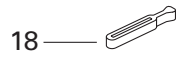
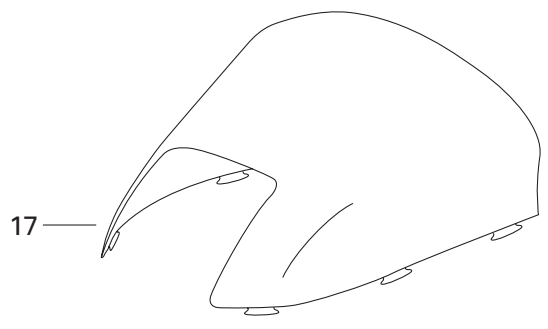
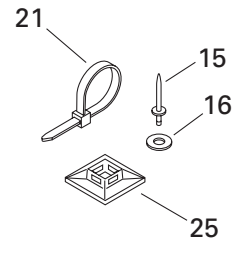

FRAME AND BODY/ CHÂSSIS ET CARROSSERIE

CAB/
CAPOT

MINI Z

1	570 025 900	Latch	Loquet	2
2	517 245 900	Bushing	Douille	2
3	390 906 800	Pop Rivet.....	Pop rivet.....	2
4	517 245 800	Knob.....	Bouton	2
5	234 151 401	Lock Washer 5 mm	Rondelle frein 5 mm	2
6	207 151 444	Hex. Screw M5 x 14	Vis hex. M5 x 14	2
7	517 225 900	Flat Washer	Rondelle plate.....	2
8	415 093 900	Retainer Cable	Câble de retenue	1
9	414 763 300	Spring	Ressort.....	1
10	415 058 300	Ring	Bague	1
11	390 407 200	Rivet	Rivet	9
12	517 302 381	Hinge Bracket.....	Attache charnière	1
13	571 009 600	Hood	Capot	1
14	517 302 046	Hinge	Charnière	1
15	390 910 200	Rivet (Yellow)	Rivet (jaune)	2
16	517 124 300	Washer	Rondelle	2
17	415 092 500	Windshield	Pare-brise	1
18	570 023 800	Windshield Latch	Loquet de pare-brise	4
19	517 298 000	Hood Guide	Guide capot	2
20	517 262 800	Bracket.....	Attache	1
21	293 750 002	Tie Rap 130 mm	Attache 130 mm.....	1
22	207 161 644	Hex. Screw M6 x 16	Vis hex. M6 x 16	3
23	232 561 414	Elastic Stop Nut M6	Écrou d'arrêt élastique M6	3
24	224 061 201	Flat Washer	Rondelle plate.....	3
25	293 750 015	Tie Rap Mount	Ancrage-attache	1
26	224 061 121	Flat Washer	Rondelle plate.....	3
27	232 061 414	Hex. Nut M6	Écrou hex. M6	3
28	293 800 060	Loctite 243, 10 cc.	Loctite 243, 10 cc.	@
29	517 302 369	R.H. Guide	Guide DR.....	1
	517 302 370	L.H. Guide.....	Guide GA.....	1
30	391 301 700	Flat Washer	Rondelle plate.....	2
31	517 302 042	Internal Cable.....	Câble interne	1
32	517 302 380	Foam	Mousse	1

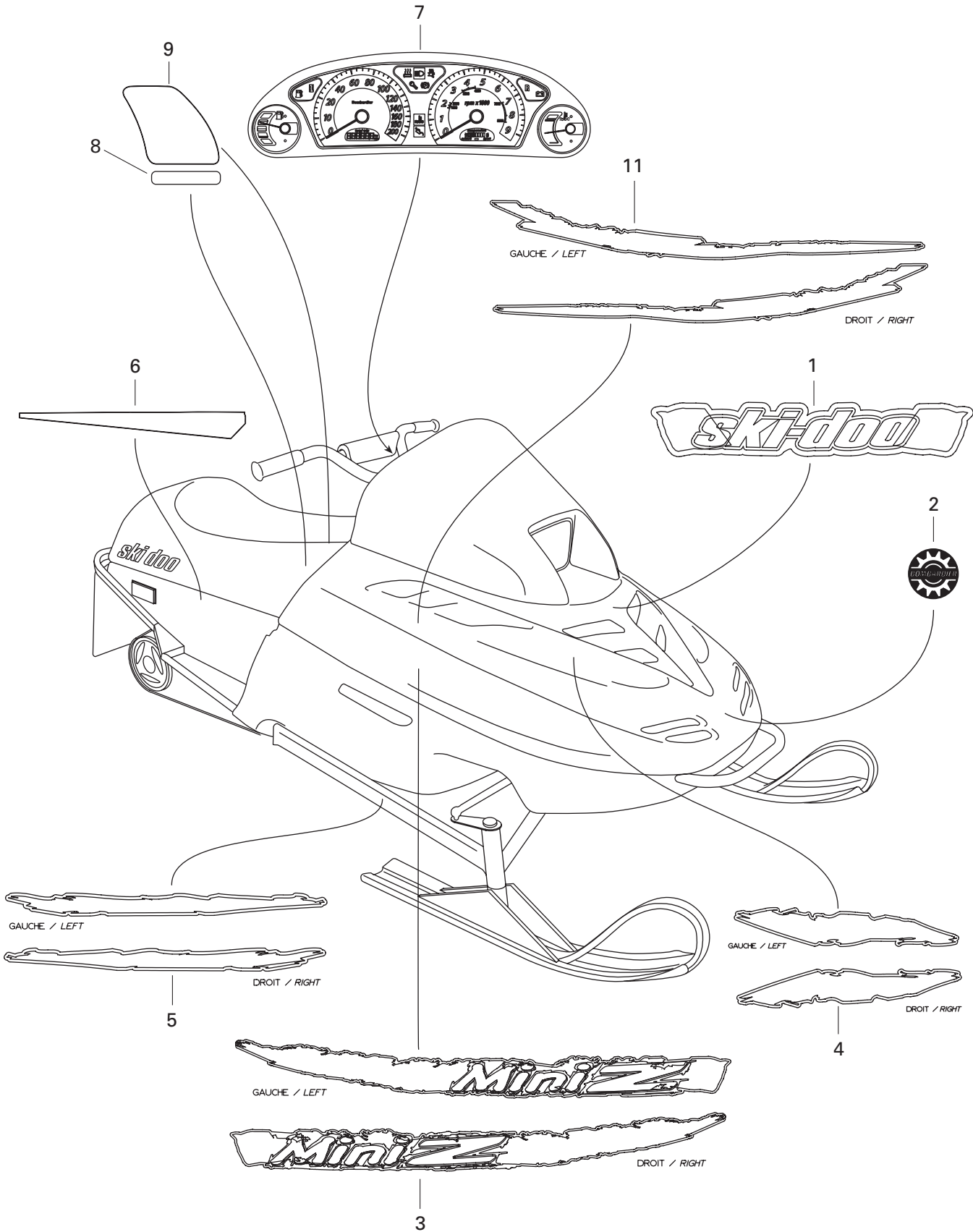

FRAME AND BODY/ CHÂSSIS ET CARROSSERIE

DECAL/
DÉCALCOMANIE

MINI Z

N 1	516 000 966	«Ski-Doo» Decal	Décalque «Ski-Doo»	1
2	516 000 673	BOMBARDIER Logo	Logo BOMBARDIER	1
N 3	415 120 114	Lat Decal Kit	Ens. de décalques latéral	1
N 4	415 120 115	Front Decal Kit	Ens. de décalques avant	1
N 5	415 120 116	Arm Decal Kit	Ens. de décalques de bras	1
6	415 121 000	Frame Decal Kit	Ens. de décalques châssis	1
N 7	418 000 984	Dash Decal	Décalque tableau de bord	1
8	516 000 001	Reflector Decal (Yellow)	Décalque réflecteur (jaune)	2
9	415 121 100	Rear Hood Decal Kit	Ens. de décalques de capot arrière	1
10	415 121 118	Hood Decal Kit (Not Shown)	Ens. de décalques de capot (non-ill.)	1
		(Incl. 1, 3, 4, 7, 8, 9, 11)	(Incl. 1, 3, 4, 7, 8, 9, 11)	
N 11	415 120 117	Upper Decal Kit	Ens de décalques supérieur	1

All labels must be ordered and installed when replacing cab.

Tous les autocollants doivent être commandés et installés lorsqu'un capot est remplacé.

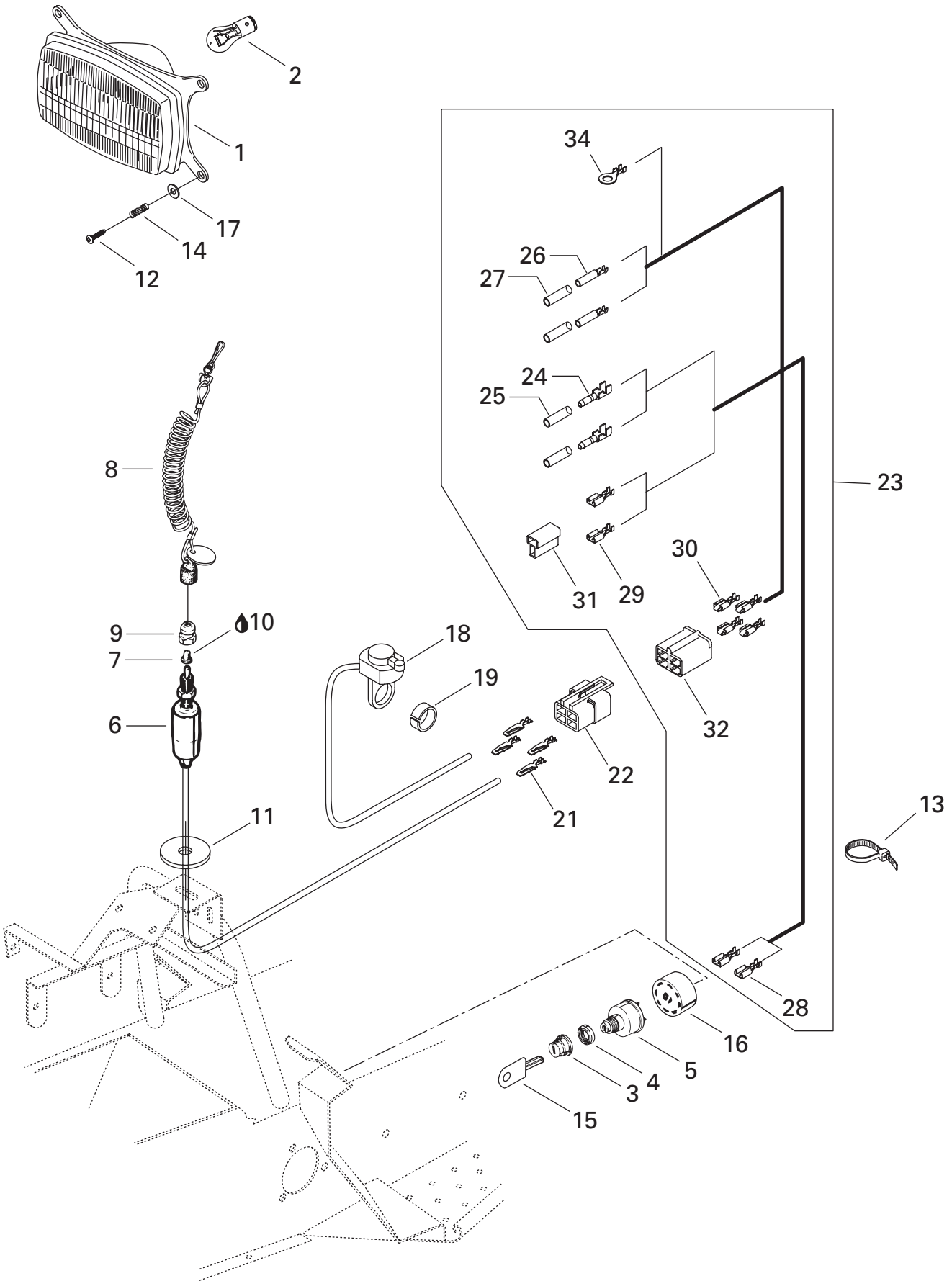

ELECTRIC SYSTEM/ SYSTÈME ÉLECTRIQUE

ELECTRICAL SYSTEM/
SYSTÈME ÉLECTRIQUE

MINI Z

1→2	410 609 200	Head Lamp Ass'y	Phare ass.	1
2	410 609 400	Bulb	Ampoule	1
3	570 013 700	Boot	Protecteur	1
4	410 112 100	Face Nut	Écrou avant.....	1
5	410 111 200	Ignition Switch	Interrupteur d'allumage	1
6	410 106 700	Brake Switch	Interrupteur de frein	1
7	570 151 100	Plunger Cap	Capuchon plongeur	1
8	515 175 105	Switch Cap Ass'y	Capuchon ass.	1
9	515 145 900	Switch Nut	Écrou interrupteur	1
10	413 701 700	Dielectric Silicone	Graisse diélectrique	@
11	517 302 008	Spacer	Espaceur	1
12	243 244 040	Screw M4 x 40	Vis M4 x 40	4
13	293 750 001	Tie Rap 94 mm	Attache 94 mm	1
	293 750 002	Tie Rap 130 mm	Attache 130 mm	8
	414 115 200	Tie Rap	Attache	1
14	517 168 600	Spring	Ressort	4
15	414 991 700	Blank Key (Plastic Pkg. 5)	Clé vierge (plastique pqt. 5)	1
16	572 150 700	Ignition Switch Block	Block de raccord	1
17	391 301 700	Flat Washer	Rondelle plate	4
18	410 105 500	Kill Switch	Interrupteur d'urgence	1
19	506 151 268	Spacer	Espaceur	1
20	515 170 100	Harness Ass'y	Câblage ass	1
21	409 210 000	Terminal Male	Cosse mâle	1
22	409 209 300	Housing Male	Logement mâle	1
23→34	515 170 100	Harness Ass'y	Câblage ass	1
24	278 000 230	Male Contact AMP	Contact mâle AMP	2
25	270 001 008	Seal Tube YASAKI	Tube isolant YASAKI	2
26	278 001 009	Female Contact AMP	Contact femelle AMP	2
27	270 001 007	Seal Tube YASAKI	Tube isolant YASAKI	2
28	561 503 100	Female Terminal ESSEX	Terminal femelle ESSEX	2
29	561 503 100	Female Terminal ESSEX	Terminal femelle ESSEX	2
30	561 503 200	Female Terminal PACKARD	Terminal femelle PACKARD	4
31	409 204 600	Female Housing PACKARD	Logement femelle PACKARD	1
32	409 204 900	Female Housing PACKARD	Logement femelle PACKARD	1
33	572 150 700	Female Housing PACKARD	Logement femelle PACKARD	1
34	278 000 992	Ring Terminal AMP	Cosse à oeillet AMP	1

**DOCUMENTATION/
DOCUMENTATIONS**NUMERICAL INDEX/
INDEX NUMÉRIQUE

206 285 044	Page B2	293 750 001	Page B10	415 087 400	Page A10	505 070 456	Page B2
207 063 044	Page A8, B7	293 750 002	Page A11, B8, B10	415 088 302	Page B7	505 070 457	Page B2
207 082 544	Page B2	293 750 015	Page B8	415 088 400	Page B7	505 070 459	Page B2
207 083 544	Page A8	293 800 060	Page A4, A8, B1, B2, B4, B8	415 088 700	Page B7	506 060 600	Page B2
207 102 544	Page B5			415 092 500	Page B8	506 147 600	Page B5
207 107 544	Page B5	303 115 900	Page B1	415 093 900	Page B8	506 151 186	Page B2
207 151 244	Page B7	309 808 900	Page B4	415 104 100	Page B5	506 151 187	Page B2
207 151 414	Page B7	369 903 000	Page B7	415 104 800	Page A8	506 151 225	Page B1
207 151 444	Page B8	371 801 000	Page B2	415 104 900	Page A4	506 151 227	Page A10
207 161 044	Page A10	389 804 300	Page B5	415 108 000	Page B5	506 151 268	Page B10
207 161 644	Page B8	390 004 800	Page B5	415 108 500	Page B2	507 031 600	Page B1
207 182 044	Page B2, B5	390 407 200	Page A8, B8	415 108 600	Page A10	507 032 229	Page B1
207 183 044	Page B6	390 409 600	Page B7	415 121 000	Page B9	512 057 400	Page A8
207 781 644	Page B4	390 502 000	Page A10, B1	415 121 100	Page B9	512 059 048	Page A11
208 562 560	Page B2	390 906 200	Page B5	415 121 118	Page B9	512 059 187	Page A8
208 651 041	Page B7	390 906 800	Page B7, B8	415 123 000	Page B4	513 032 924	Page A10
211 400 016	Page B4	390 910 200	Page B7, B8	415 127 453	Page A10	514 098 700	Page A8
224 002 251	Page B5	391 301 700	Page B8, B10	415 127 693	Page A6	515 145 900	Page B10
224 061 121	Page A10, B4, B8	400 101 103	Page A8	415 127 694	Page A6	515 170 100	Page B10
224 061 201	Page B2, B8	405 404 500	Page B5	417 126 304	Page B4	515 175 105	Page B10
224 081 201	Page A8, B1	409 204 600	Page B10	417 217 200	Page B1, B4	515 175 451	Page A9
224 701 188	Page B5	409 204 900	Page B10	417 300 005	Page B1	516 000 001	Page B9
224 761 110	Page A10	409 209 300	Page B10	417 300 006	Page B1	516 000 131	Page B1
232 006 414	Page B2, B5	409 210 000	Page B10	501 025 000	Page B4	516 000 673	Page B9
232 061 414	Page B8	410 105 500	Page B10	502 006 505	Page B7	517 124 300	Page B8
232 081 414	Page B2	410 106 700	Page B10	502 006 538	Page B7	517 126 200	Page B2
232 201 414	Page B3	410 111 200	Page B10	502 006 539	Page B7	517 168 600	Page B10
232 551 414	Page B7	410 112 100	Page B10	503 149 800	Page B5	517 225 900	Page B8
232 561 414	Page A8, B2, B4, B7, B8	410 609 200	Page B10	503 161 400	Page B5	517 245 800	Page B8
232 581 414	Page B1, B2, B3, B4, B5	410 609 400	Page B10	503 161 500	Page B5	517 245 900	Page B8
232 802 400	Page B5	412 107 500	Page B4	503 176 800	Page B5	517 262 800	Page B8
233 281 414	Page B3	412 500 100	Page A7	503 177 000	Page B2	517 298 000	Page B8
234 001 410	Page B2	413 701 700	Page A9, B10	503 177 200	Page B5	517 302 008	Page B10
234 051 410	Page A8, B7	413 711 500	Page B2	503 177 300	Page B5	517 302 042	Page B8
234 061 410	Page A8, B7	414 115 200	Page B10	503 177 400	Page B5	517 302 046	Page B8
234 081 410	Page B2, B3, B4	414 274 500	Page A10, B1	503 177 700	Page B5	517 302 369	Page B8
234 082 410	Page B4, B5	414 404 800	Page B7	503 177 800	Page B5	517 302 370	Page B8
234 100 602	Page B2	414 510 100	Page B7	503 178 000	Page B5	517 302 380	Page B8
234 151 401	Page B8	414 554 800	Page A10	503 178 100	Page B5	517 302 381	Page B8
234 161 471	Page A8	414 580 600	Page A10	503 178 200	Page B5	518 320 400	Page B7
234 180 411	Page B5	414 612 400	Page A11	503 178 400	Page B5	518 321 300	Page B7
234 181 401	Page B2, B4	414 763 300	Page B8	503 183 300	Page B5	518 321 943	Page B7
234 451 418	Page B7	414 806 800	Page B7	503 188 900	Page B5	518 321 950	Page B7
234 461 608	Page A9, A10	414 865 700	Page A10	504 018 200	Page B4	518 321 952	Page B7
243 244 040	Page B10	414 880 400	Page B5	504 051 600	Page B4	561 503 100	Page B10
270 001 007	Page B10	414 880 500	Page B5	504 108 200	Page B5	561 503 200	Page B10
270 001 008	Page B10	414 920 600	Page A4	504 149 500	Page B4	570 013 700	Page B10
275 500 398	Page A10	414 991 700	Page B10	504 149 600	Page B1	570 023 800	Page B8
278 000 230	Page B10	415 058 300	Page B8	504 150 500	Page B4	570 025 900	Page B8
278 000 992	Page B10	415 064 400	Page B7	504 150 600	Page B4	570 027 700	Page A10
278 001 007	Page A9	415 064 401	Page B7	504 151 794	Page B4	570 028 700	Page A8
278 001 009	Page B10	415 080 200	Page A10	505 068 300	Page B2	570 044 700	Page A8
		415 086 300	Page B1	505 068 400	Page B2	570 045 500	Page A10
		415 087 300	Page B2	505 070 178	Page B2	570 047 900	Page B5

**DOCUMENTATIONS/
DOCUMENTATIONS**NUMERICAL INDEX/
INDEX NUMÉRIQUE

570 067 300 Page B5
570 068 700 Page B5
570 069 200 Page B6
570 128 800 Page B2
570 151 100 Page B10
570 211 900 Page B4
571 009 500 Page B7
571 009 600 Page B8
571 009 800 Page A10
572 039 600 Page A10
572 041 600 Page B4
572 064 100 Page B2
572 064 400 Page B2
572 064 500 Page B2
572 067 100 Page B2
572 079 100 Page B2
572 097 612 Page B5
572 099 500 Page B2
572 099 800 Page B7
572 103 400 Page B2
572 110 500 Page B5
572 150 700 Page B10
583 183 400 Page A8

H

H11300ZE0640 Page A4
H11347371300 Page A9
H11381ZH7800 Page A4
H120A0ZH7810 Page A4
H12204ZE1306 Page A6
H12210ZH7000 Page A6
H12216ZE5300 Page A6
H12251ZH7800 Page A6
H12310ZE1000 Page A6
H12391ZE1000 Page A6
H13010ZE6013 Page A4
H13011ZE6013 Page A4
H13012ZE6013 Page A4
H13013ZE6013 Page A4
H13101ZH7000 Page A5
H13102ZH7000 Page A5
H13103ZH7000 Page A5
H13104ZH7000 Page A5
H13111ZE0000 Page A5
H13200ZE0000 Page A5
H132A0ZE0000 Page A5
H13310ZE0601 Page A4
H13331357000 Page A9
H14100ZE0812 Page A6
H14410ZE0010 Page A6
H14431ZE1000 Page A6
H14441ZE1010 Page A6
H14451ZE1013 Page A6
H14568ZE1000 Page A6
H14711ZF0000 Page A6
H14721ZF0000 Page A6
H14751ZF1000 Page A6
H14771ZE1000 Page A6
H14773ZE1000 Page A6
H14781ZE1000 Page A6
H14791ZE0010 Page A6
H15600ZE1003 Page A4
H15600ZG4003 Page A4
H15625ZE1003 Page A4
H15721ZH8000 Page A6
H16010ZE1812 Page A12
H16011ZE0005 Page A12
H16013ZE0005 Page A12
H16015ZE1811 Page A12
H16016ZE0005 Page A12
H16024ZE1811 Page A12
H16028ZE0005 Page A12
H16044ZE0005 Page A12
H16100ZK7U51 Page A8, A12
H16124ZE0005 Page A12
H16166ZH7W50 Page A12
H16211ZE0000 Page A12
H16212ZH7800 Page A12
H16220ZE1020 Page A12
H16221ZH8801 Page A12
H16500ZH7810 Page A10
H16500ZK7U50 Page A11
H16510ZE1000 Page A4
H16511ZE1000 Page A4
H16512ZE1000 Page A4
H16513ZE1000 Page A4
H16531ZE1000 Page A4
H16541ZE1000 Page A4
H16551ZE1010 Page A11
H16555ZE0000 Page A11
H16561ZE0020 Page A11
H16562ZE0020 Page A11
H16571ZH7000 Page A10
H16574ZE1000 Page A10
H16575ZH8000 Page A10
H16576891000 Page A10
H16578ZE1000 Page A10
H16580ZH7810 Page A10
H16582883300 Page A12
H16584883300 Page A10
H16594883010 Page A10
H16598ZE1000 Page A12
H16610ZE1810 Page A12
H16617890010 Page A12
H16953ZE1406 Page A12
H16954ZE1812 Page A12
H16955283000 Page A12

H16956ZE1811 Page A12
H16957ZE1812 Page A12
H16967ZE0811 Page A12
H17230ZE0820 Page A10
H17238ZE0010 Page A10
H17239ZE1000 Page A10
H17410ZE0030 Page A10
H18381ZH8800 Page A8
H19511ZE0000 Page A9
H19610ZE0000ZQ Page A9
H19612ZH7820 Page A9
H19630ZH7000 Page A9
H28400ZH8013ZV Page A7
H28410ZH8003ZV Page A7
H28420ZH8013 Page A7
H28422ZH8013 Page A7
H28433ZH8003 Page A7
H28441ZH8003 Page A7
H28442ZH8003 Page A7
H28443ZH8003 Page A7
H28451ZH8003 Page A9
H28461ZH8003 Page A7
H30500ZE1033 Page A9
H30700ZE1013 Page A9
H31510ZK7U50 Page A9
H31511ZE1000 Page A9
H31512ZE1000 Page A9
H36100ZH7003 Page A9
H36101ZK7U50 Page A9
H81329567020 Page A9
H90001ZE1000 Page A4
H90003ZH8003 Page A7
H90012ZE0010 Page A6
H90013883000 Page A6, A9, A11
H90015883000 Page A4, A9
H90015ZE5010 Page A11
H90019883000 Page A9
H90022888010 Page A9, A11
H90043ZE1020 Page A6
H90047ZE1000 Page A6
H90114SA0000 Page A10
H90121952000 Page A9
H90131ZE1000 Page A4
H90201878003 Page A9
H90206ZE1000 Page A6
H90325044000 Page A10
H90451ZE1000 Page A4
H90551ZE0000 Page A4
H90601ZE1000 Page A4
H90601ZH7013 Page A9
H90602ZE1000 Page A4
H90605230000 Page A10, A12
H90745ZE1600 Page A4
H91001878003 Page A4

H91202ZE6003 Page A4
H91203ZE0003 Page A4
H93500030080G Page A12
H93500040060H Page A10
H93500040080A Page A12
H93500050080A Page A12
H93500050160B Page A10
H93500050250H Page A11
H94001080000S Page A8
H9405006080 Page A10, A11
H9410106700 Page A4
H9425108000 Page A4
H9430108140 Page A4
H9430110160 Page A6
H9430520122 Page A12
H957010600800 Page A7
H957010602000 Page A10
H957230805500 Page A6
H9807955855 Page A6
H9807956855 Page A6
H99101ZH70650 Page A12
H99101ZH70680 Page A12
H99101ZH80620 Page A12
H99204ZE00350 Page A12

N

N 415 120 114 Page B9
N 415 120 115 Page B9
N 415 120 116 Page B9
N 415 120 117 Page B9
N 418 000 984 Page B9
N 504 152 022 Page B4
N 504 152 025 Page B4
N 504 152 029 Page B4
N 506 151 419 Page B2
N 506 151 421 Page B2
N 506 151 422 Page B2
N 507 032 289 Page B1
N 507 032 297 Page B1
N 510 003 910 Page B7
N 512 059 347 Page A4
N 516 000 966 Page B9

BOMBARDIER
PRODUITS RÉCRÉATIFS



*Trademarks of Bombardier Inc. and/or its subsidiaries.
© 2000 Bombardier Inc. All rights reserved.
Printed in Canada.

© *Marque de commerce Bombardier Inc. et/ou de ses filiales.
© 2000 Bombardier Inc. Tous droits réservés.
Imprimé au Canada.