

TABLE OF CONTENTS

SC-10 II SUSPENSION	07-02-1
SUSPENSION ASSEMBLY REMOVAL	07-02-4
DISASSEMBLY AND ASSEMBLY	07-02-5
BOSS SHOCK ABSORBER SERVICING	07-02-7
SHOCK ABSORBER INSPECTION	07-02-7
HPG T/A SHOCK SERVICING.....	07-02-8
INSTALLATION	07-02-15
RIDE ADJUSTMENT	07-02-15
LUBRICATION	07-02-15

SC-10 MOUNTAIN SUSPENSION	07-03-1
COMPONENT REMOVAL AND INSTALLATION	07-03-4
SUSPENSION ASS'Y REMOVAL	07-03-5
DISASSEMBLY AND ASSEMBLY	07-03-6
SHOCK ABSORBER INSPECTION	07-03-7
HPG T/A SHOCK SERVICING.....	07-03-8
INSTALLATION	07-03-8
RIDE ADJUSTMENT	07-03-8
LUBRICATION	07-03-8

DRIVE AXLE	07-04-1
REMOVAL.....	07-04-2
ASSEMBLY.....	07-04-3
LUBRICATION	07-04-4
ADJUSTMENT.....	07-04-4

TRACK	07-05-1
TRACK TYPE APPLICATION.....	07-05-1
GENERAL	07-05-1
INSPECTION	07-05-1
REMOVAL.....	07-05-1
INSTALLATION	07-05-1

SC-10 II SUSPENSION

SC-10 II

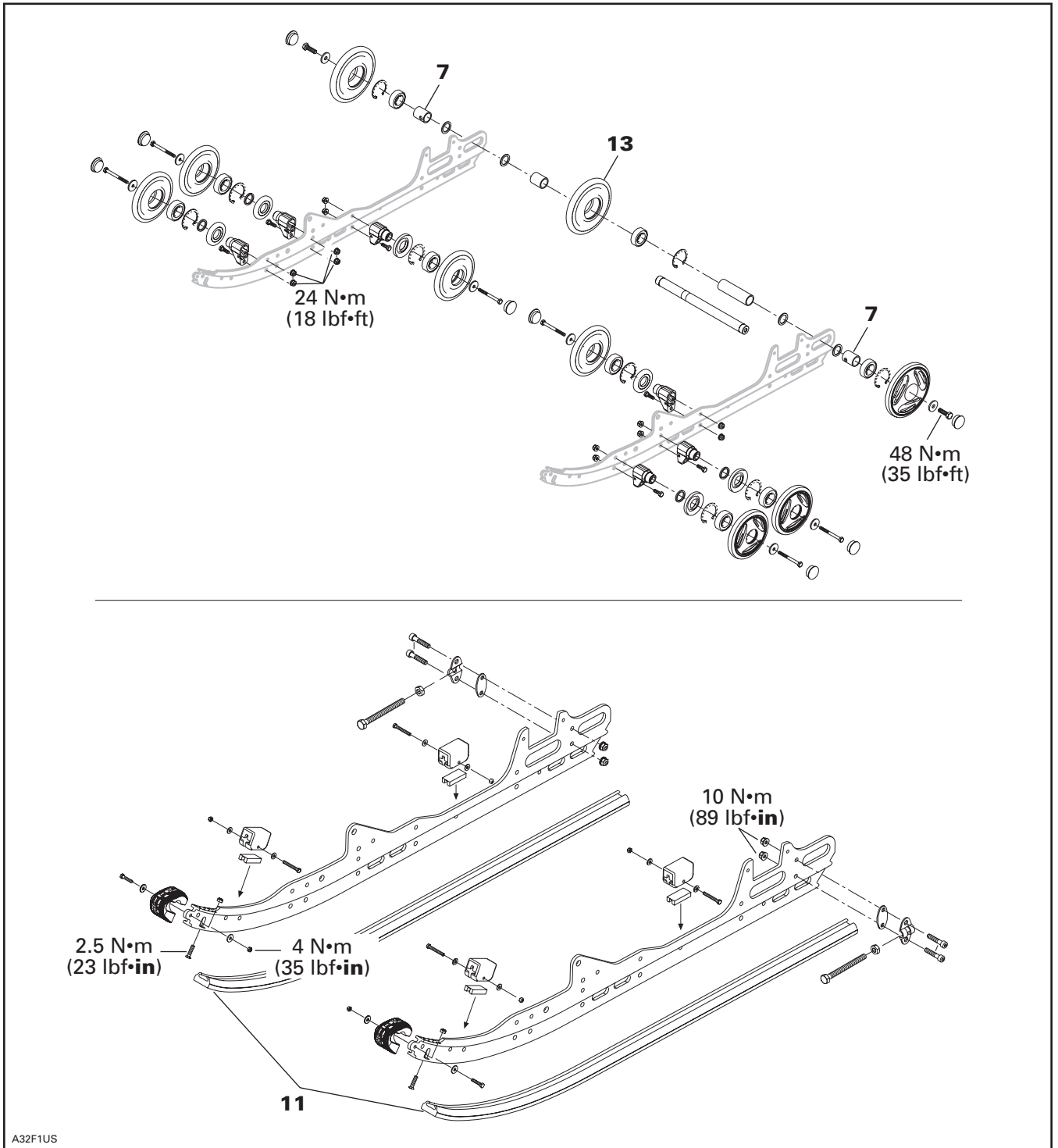

A32F1US

Section 07 REAR SUSPENSION

Subsection 02 (SC-10 II SUSPENSION)

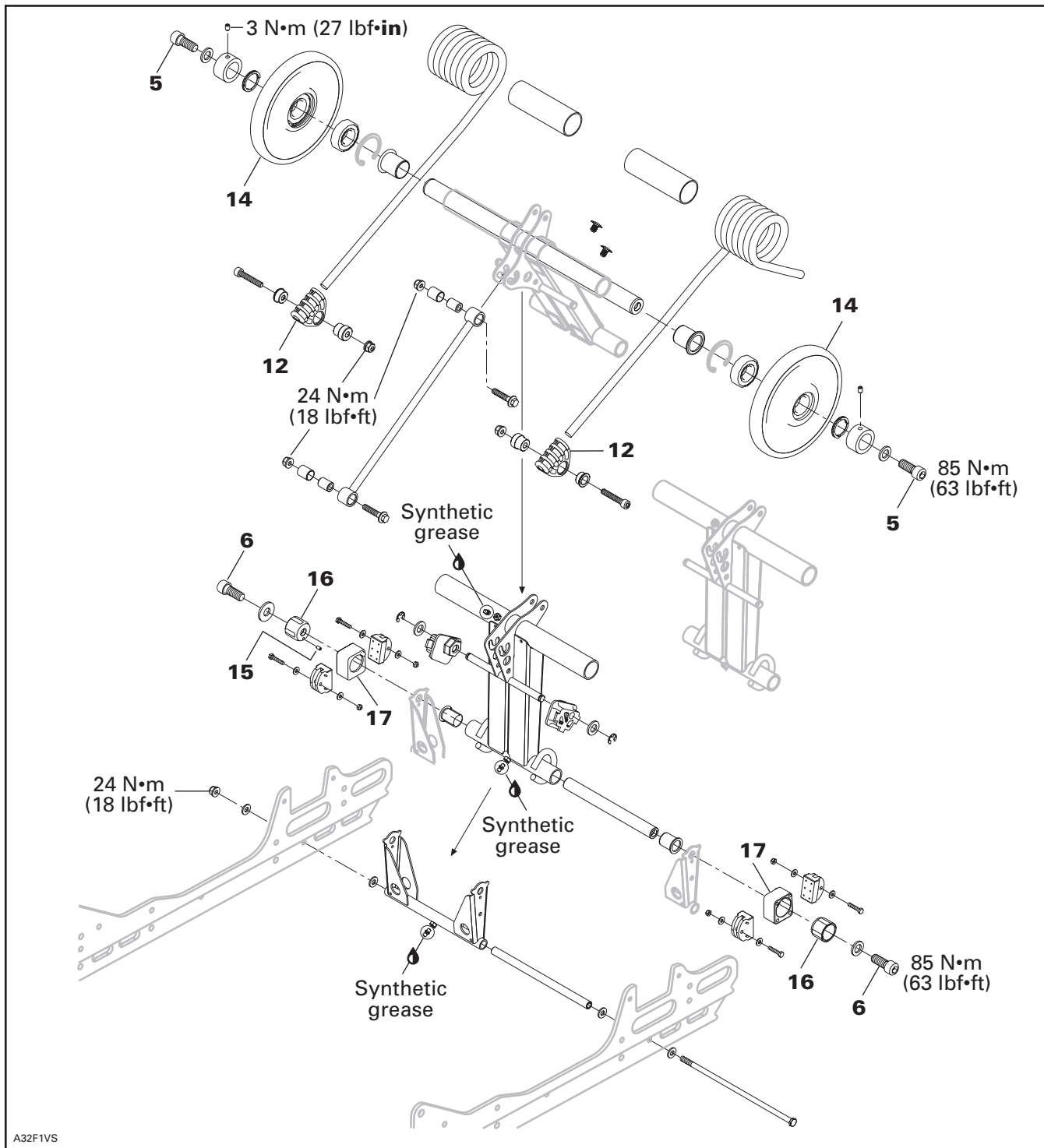

Section 07 REAR SUSPENSION
 Subsection 02 (SC-10 II SUSPENSION)

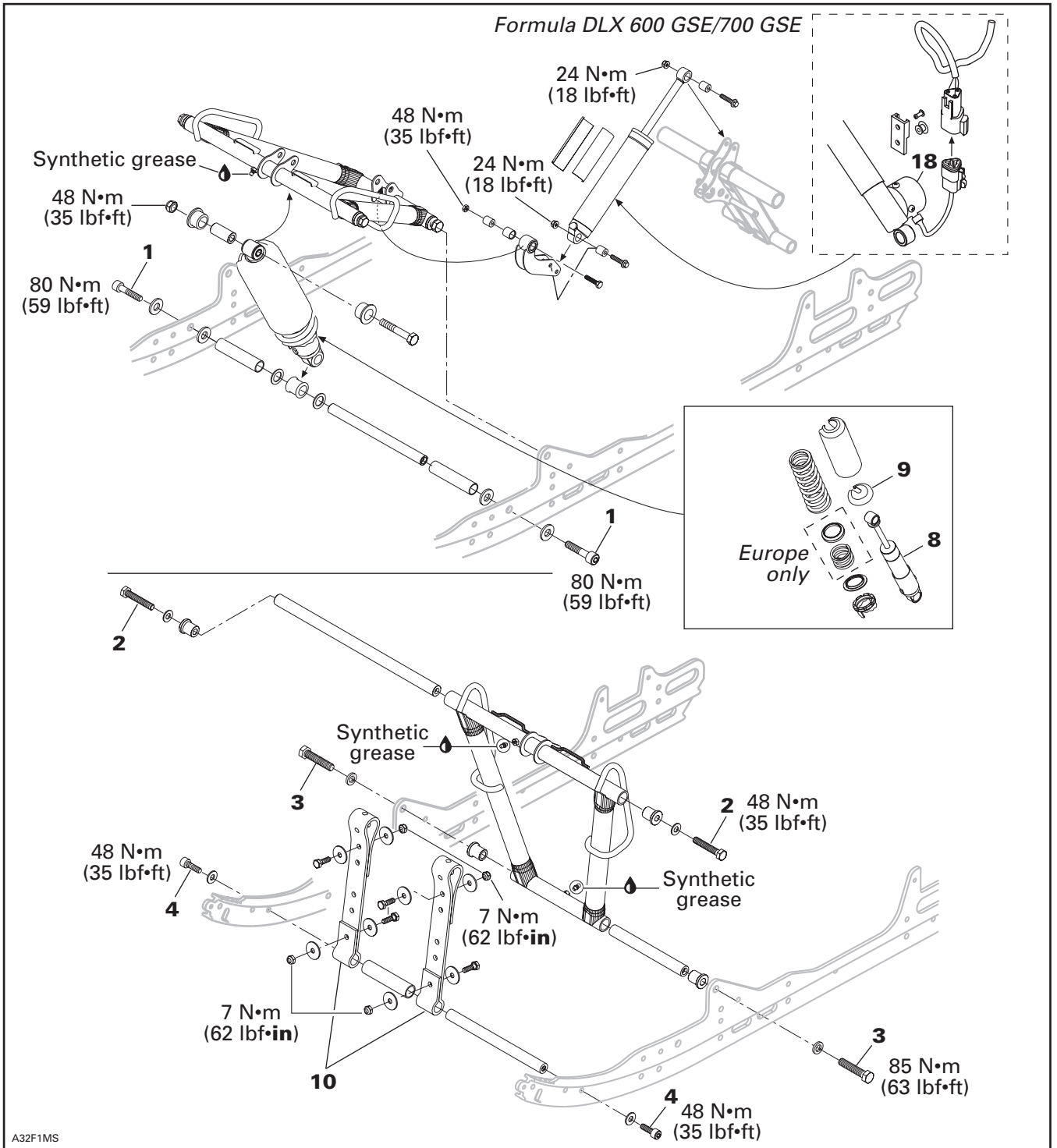

Section 07 REAR SUSPENSION

Subsection 02 (SC-10 II SUSPENSION)

SUSPENSION ASSEMBLY REMOVAL

19, Cam

Decrease spring preload by turning cams accordingly.

Slightly turn adjusting cam to expose spring end. Using spring installer (P/N 529 005 000), remove both springs from adjusting cams.

- Remove the opposite self-locking screw.
- Remove the temporary installed non-self-locking screw.
- If it doesn't work, heat bolt head to melt thread-locker.

Remove rear arm top axle self-locking screws no. 5 from chassis.

Lift rear of vehicle at least 1 m (3 ft).



529 005 000

A03F2FB

TYPICAL

Lift rear of vehicle and support it off the ground.
Loosen track tension.

1,2,3,4,5,6, Self-Locking Screws

CAUTION: These self-locking screws must always be replaced by new ones everytime they are removed.

NOTE: To prevent axle from turning when unscrewing self-locking screws, proceed as follows:

- Remove one self-locking screw then install a 10 mm shorter non-self-locking one in place. Torque as specified in exploded view.



A32F10A

TYPICAL

A. At least 1 m (3 ft)

Remove both self-locking screws no. 2 retaining front arm to tunnel.

Remove suspension.

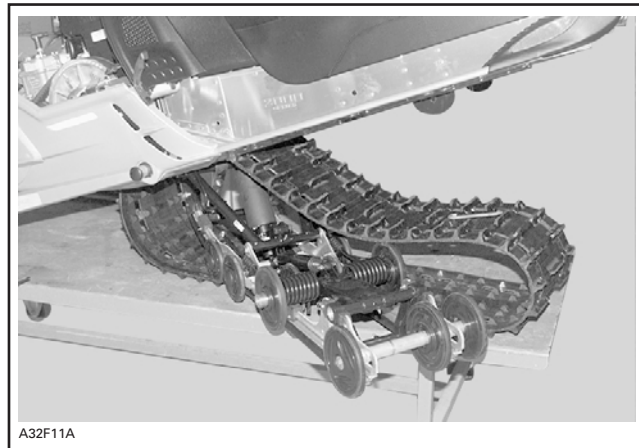

A32F11A

Section 07 REAR SUSPENSION
Subsection 02 (SC-10 II SUSPENSION)

DISASSEMBLY AND ASSEMBLY

Inspect track thoroughly before reinstalling suspension. Refer to TRACK.

7, Outer Bushing

At installation, hole must face adjustment screw.

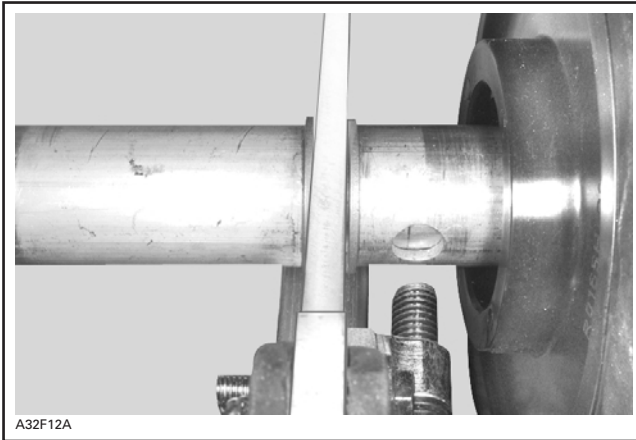

13,14, Center Rear Wheel and Top Idler Wheels

At installation, circlip must face inner side.

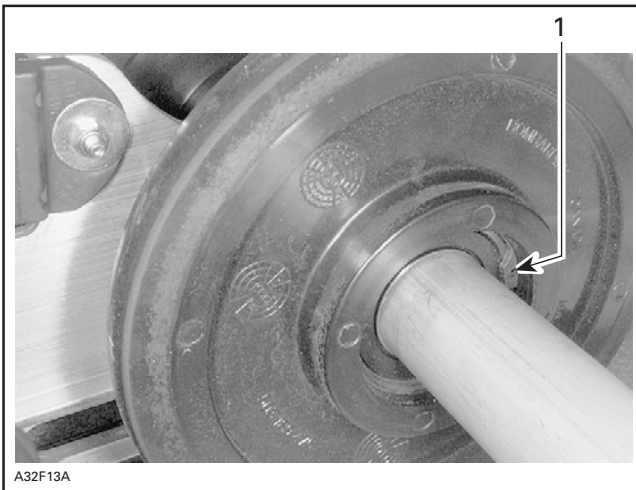

1. Circlip facing inner side

17, Block

Both blocks are identified R or L (right or left), see second following photo. At installation, make sure to install proper block on proper side.

Also, note that protrusion must be positioned above stoppers.

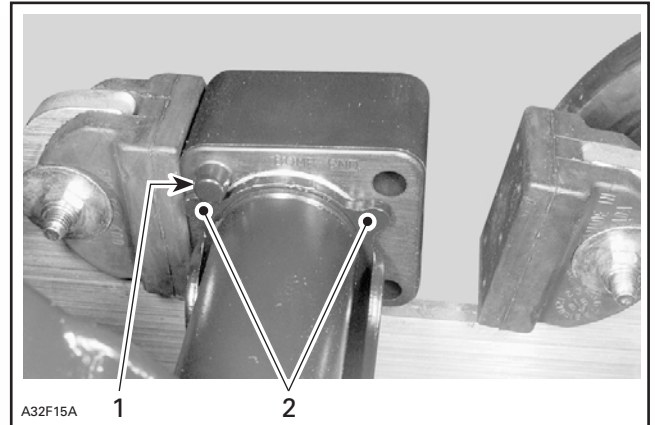

1. Protrusion
2. Stoppers

15,16, Dowel Pin and Block Guide

Dowel pin must exceed block guide by 2 to 2.3 mm (.079 to .091 in).

At installation, insert dowel pin into pivot arm hole.

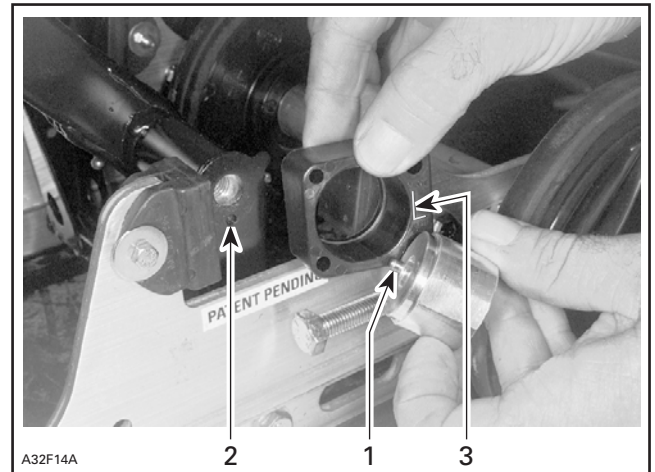

LEFT SIDE SHOWN

1. Dowel pin
2. Pivot arm hole
3. "L" identification for left side

Section 07 REAR SUSPENSION

Subsection 02 (SC-10 II SUSPENSION)

8,9, Front Shock and Spring Stopper

Use shock spring remover (P/N 529 035 504) and put it in a vise. Mount shock in it and turn shock so that spring coils matched spring compressor.

Close and lock bar. Adjust handle horizontal by changing position of clevis pin.

Push down on handle until it locks. Remove spring stopper then release handle.

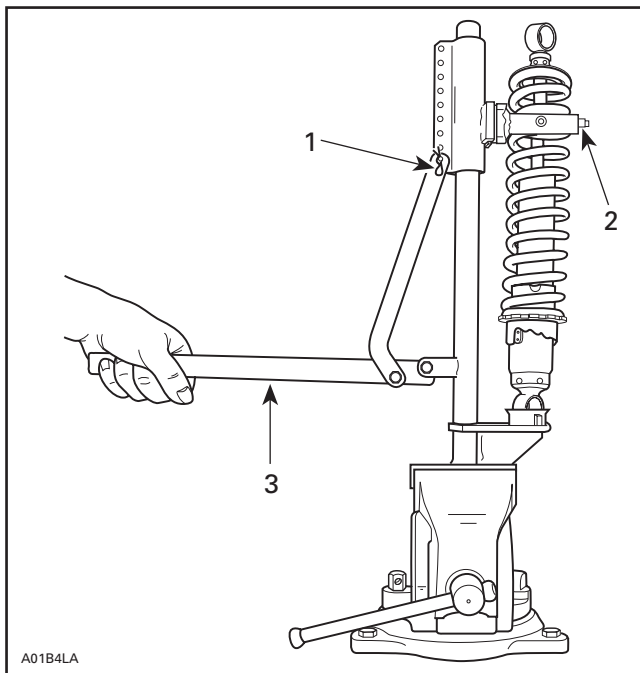

1. Clevis pin
2. Bar
3. Handle horizontal

10, Stopper Strap

Inspect strap for wear or cracks, bolt and nut for tightness. If loose, inspect hole for deformation. Replace as required. Make sure it is attached through proper holes. Torque nut to 7 N•m (62 lbf•in).

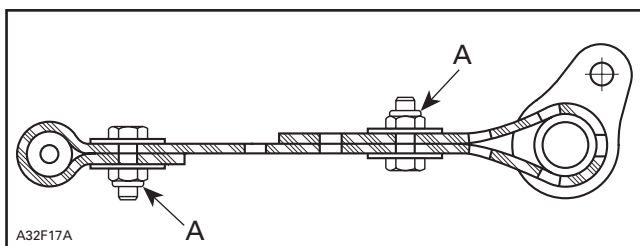

- A. 7 N•m (62 lbf•in)

11, Slider Shoe

Molding line is the wear limit indicator.

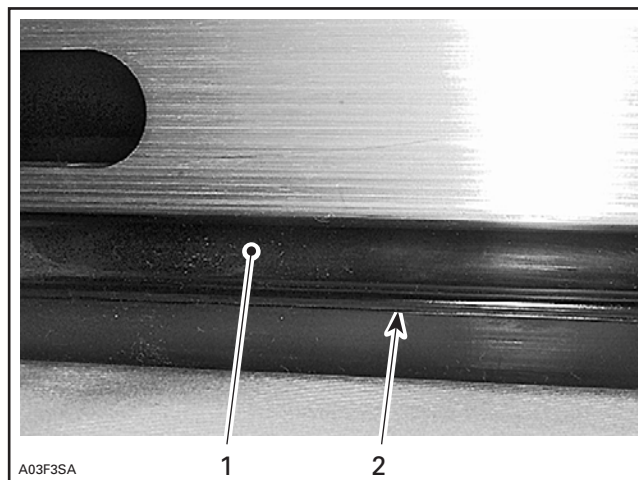

TYPICAL

1. Slider shoe
2. Molding line (wear limit indicator)

Replace slider shoes when wear limit is reached.

CAUTION: Slider shoes must always be replaced in pairs.

12, Spring Support

CAUTION: To avoid track damage, spring supports must be mounted upward.

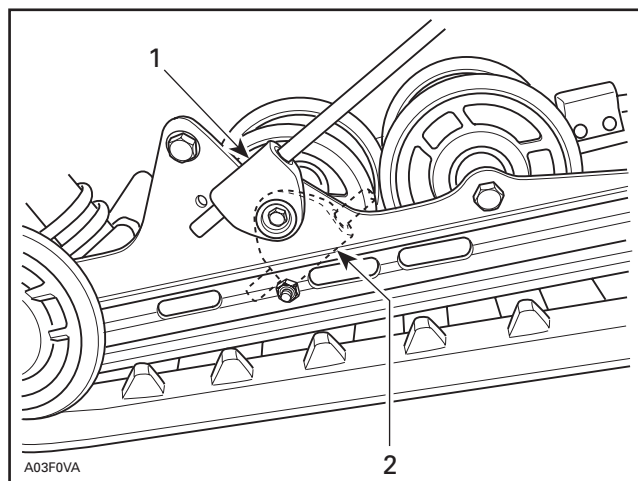

TYPICAL — RIGHT SIDE SHOWN

1. Right position: upward
2. Wrong position

BOSS SHOCK ABSORBER SERVICING

Formula DLX 600 GSE and 700 GSE

Only the actuator can be replaced.

Remove actuator retaining screws.

Connect actuator black wire (connector no. 3) to a 12-volt battery negative post.

To select COMFORT position apply positive to yellow wire (connector no. 2) for one second. Actuator shaft must be in following position.

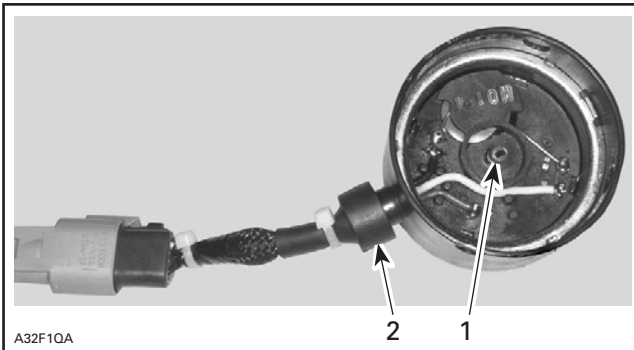

COMFORT POSITION — SHAFT SLOT IN LINE WITH WIRE HARNESS

1. Shaft
2. Wire harness

To select SPORT position apply positive to blue wire (connector no. 1) for one second. Actuator shaft must be in following position.

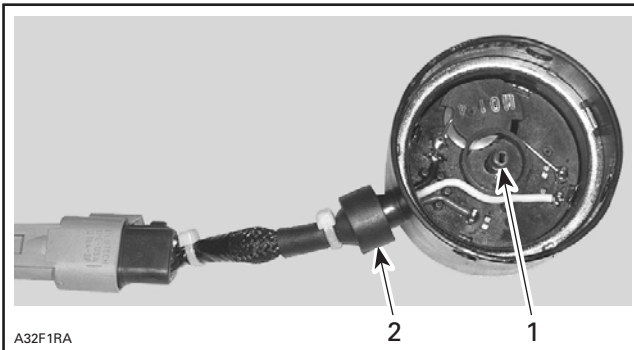

SPORT POSITION — SHAFT SLOT ABOUT 45° FROM WIRE HARNESS

1. Shaft
2. Wire harness

Replace actuator otherwise.

When reassembling actuator to shock body align shaft slot with valve tip. Wire harness must face shock body end.

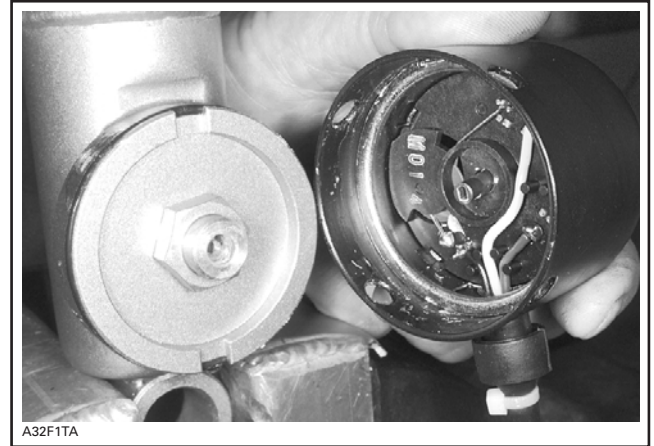

SHOCK ABSORBER INSPECTION

All Models Equipped with Hydraulic Shock

NOTE: Hydraulic shocks are painted black or dark gray.

Secure the shock body end in a vise with its rod upward.

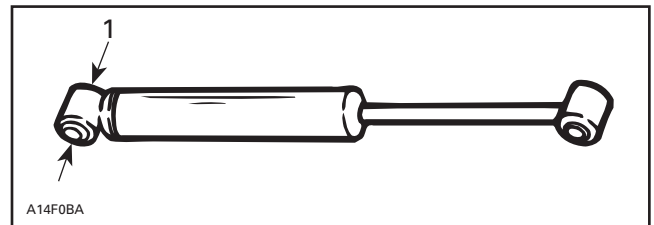

1. Clamp

CAUTION: Do not clamp directly on shock body.

Examine each shock for leaks. Extend and compress the piston several times over its entire stroke. Check that it moves smoothly and with uniform resistance with its rod upward.

Pay attention to the following conditions that will denote a defective shock:

- A skip or a hang back when reversing stroke at mid travel.
- Seizing or binding condition except at extreme end of either stroke.
- Oil leakage.
- A gurgling noise, after completing one full compression and extension stroke.

Renew if any faults are present.

Section 07 REAR SUSPENSION

Subsection 02 (SC-10 II SUSPENSION)

All Models Equipped with Gas Pressurized Shock

NOTE: Gas pressurized shocks are light gray or purple painted, or bare aluminum.

Gas shock can be inspected as follows:

Because of gas pressure, strong resistance is felt when compressing shock. When released, the shock will extend unassisted. Renew as required.

If suspecting an internal gas leak between oil chamber and gas chamber, check shock as follows:

Install shock in a vise clamping on its bottom eye-let with its rod upward.

Let it stand for 5 minutes.

Completely push down the shock rod then release.

Rod must come out at a steady speed. If speed suddenly increases particularly at end of extension, replace shock.

All Types of Shock

If suspecting a frozen shock proceed as follows:

Place shock in a freezer (temperature below 0°C (32°F)) for 4 hours.

Push down on rod and note its resistance. If shock is frozen it will be impossible or almost impossible to compress it.

HPG T/A SHOCK SERVICING

Disassembly and Assembly

There are two types of high pressure gas take apart (HPG T/A) shock. One type has a tire valve and the other has a needle valve.

SHOCK TYPE	INFLATION TOOL
Tire valve type	529 035 570
Needle valve type	529 035 614

T/A shocks come in two sizes. C-36 shock is 36 mm (1.417 in) in diameter and C-46 shock is 46 mm (1.811 in).

SHOCK SIZE	SERVICING TOOL
C-36	Piston guide 529 026 600
	Seal guide 529 026 500
	Shock wrench 529 035 727
C-46	Piston guide 529 035 608
	Seal guide 529 035 728
	Shock wrench 529 035 727

Release N₂ (nitrogen) pressure on any HPG T/A shock with internal floating piston (IFP).

WARNING

Nitrogen gas is under extreme pressure. Use caution when releasing this gas volume. Protective eye wear should be used.

All T/A Shock Types

Mount shock in a vise.

Tire Valve Type Shock

Remove tire valve cap and push on center rod of valve to release gas pressure.

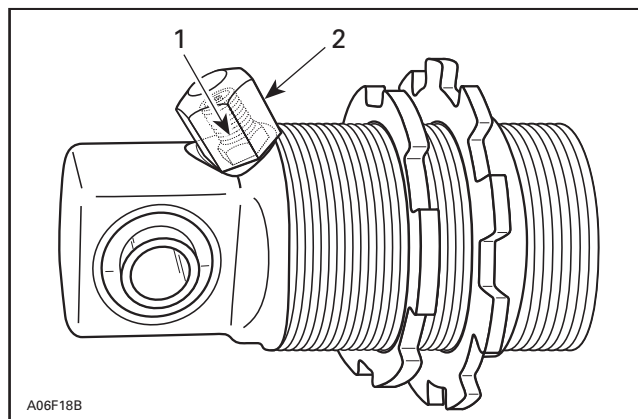

1. Tire valve
2. Tire valve cap

Section 07 REAR SUSPENSION
Subsection 02 (SC-10 II SUSPENSION)

Needle Valve Type Shock

Remove screw on top of valve. Insert needle type shock tool (P/N 529 035 614) very slowly into rubber of needle valve. Push on shock tool valve center rod to release gas pressure.



Remove tool from shock.

All Types of Shock

Using appropriate size of shock wrench (P/N 529 035 727) unscrew seal carrier.

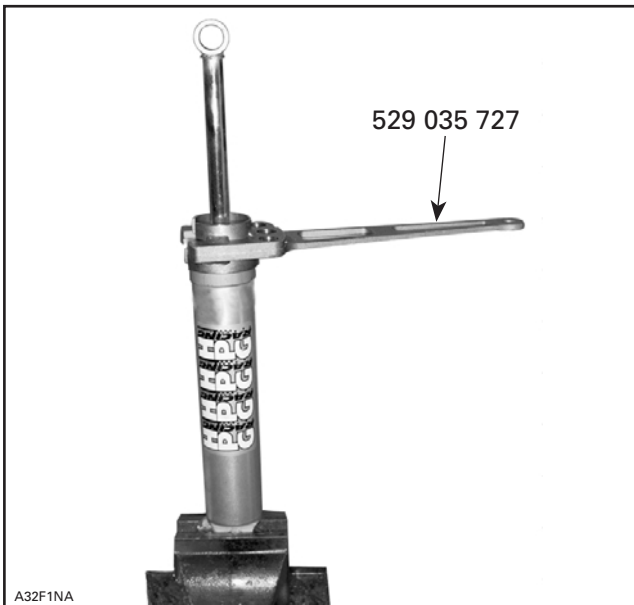

TYPICAL

With the seal carrier removed, slowly lift and remove damper rod assembly from the damper body.

NOTE: Remove damper rod assembly slowly to reduce oil spillage and prevent piston seal damage by damper body threads. Wrap the damper body with a shop cloth to capture possible overflow oil while removing the damper piston.

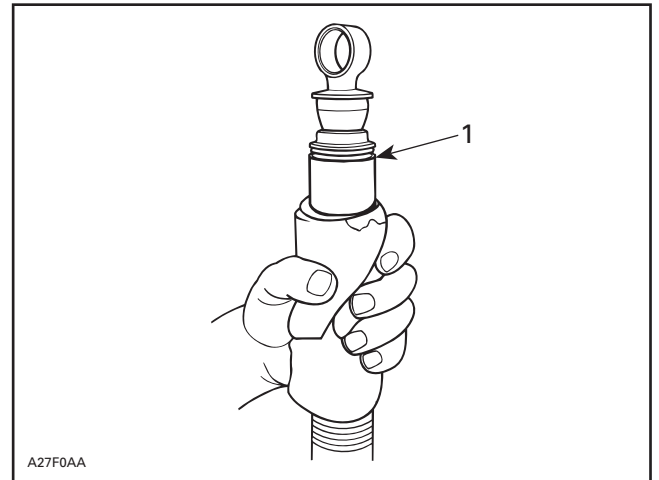

1. Oil flows

Discard old oil into storage container. Never reuse damper oil during shock rebuild.

Remove valve core. Using compressed air pressure, carefully remove floating piston from damper body. Hold shop cloth over damper body opening to catch released floating piston. Allow room for floating piston to leave damper body.

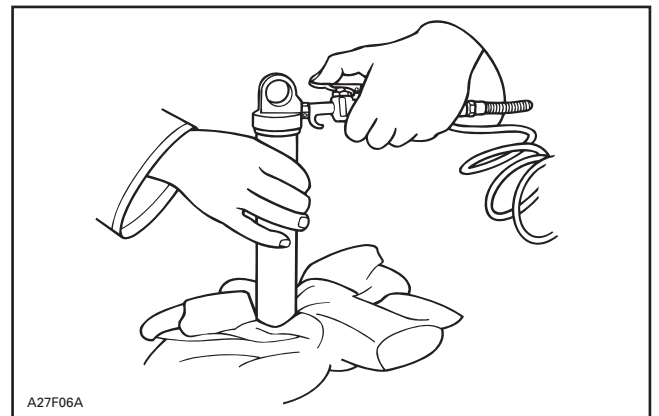

TYPICAL

⚠ WARNING

Whenever using compressed air, use an O.S.H.A. approved air gun and wear protective eye wear.

Section 07 REAR SUSPENSION

Subsection 02 (SC-10 II SUSPENSION)

Thoroughly clean, with a typical cleaning solution, and blow dry using low pressure air. Carefully inspect the damper body for any imperfections or signs of wear in the damper bore.

Replace damper body if wear is identified.

Holding the damper rod assembly in a bench vise, begin piston and valve removal.

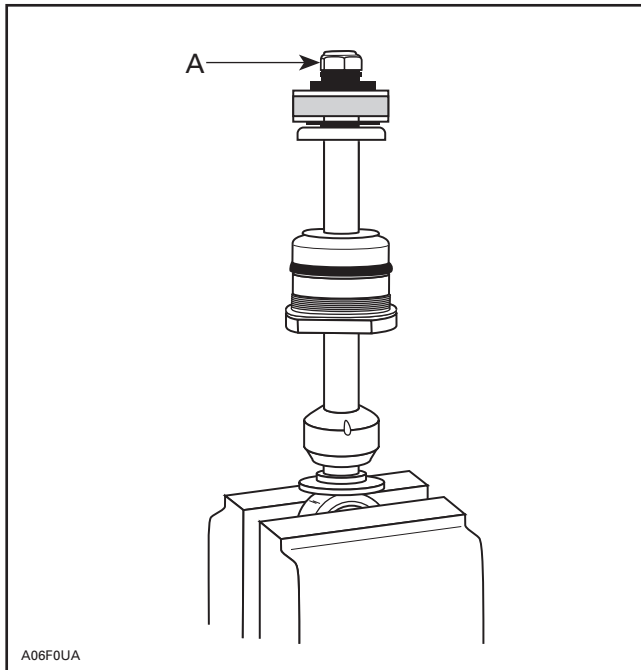

A. Remove damper nut

Always arrange parts removed in the sequence of disassembly.

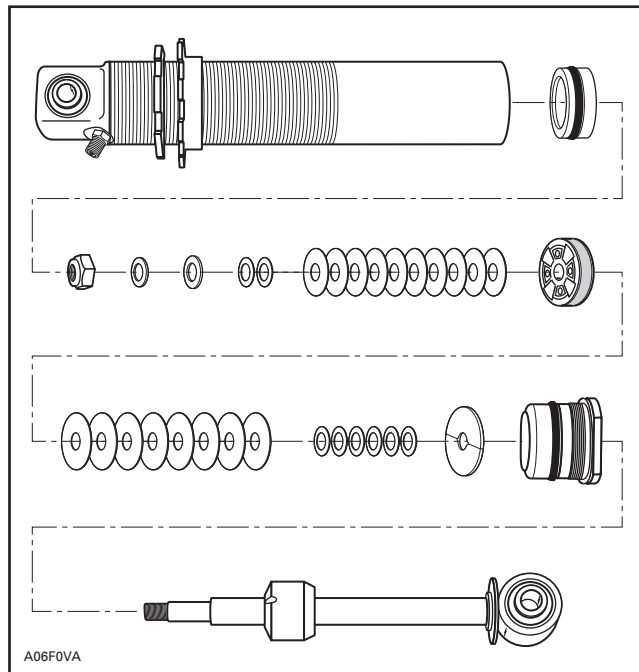

NOTE: As a general rule we suggest replacing the damper rod lock-nut after 4 rebuilds to ensure good locking friction and use Loctite[†] 271 each time.

NOTE: If revalving is to be done, it is imperative that you identify the original shim pack (size and number of shims). The seal carrier need not be removed if only revalving is to be done.

Shims can be measured by using a vernier caliper or a micrometer.

NOTE: All shims should be carefully inspected and any bent or broken shims must be replaced for the shock to function properly.

After the new or replacement shim pack has been selected, reassemble in the reverse order of disassembly. Torque piston nut 27 - 29 N•m (20 - 21 lbf•ft).

Section 07 REAR SUSPENSION

Subsection 02 (SC-10 II SUSPENSION)

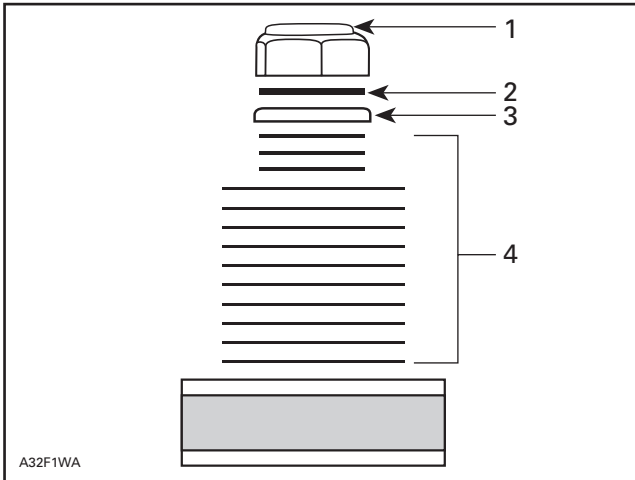

1. Damper nut
2. Spacer
3. Stopper with its round edge facing nut
4. Shim pack

CAUTION: The damper rod nut can only be re-used 4 times, then, must be replaced. Do not substitute this part for non – O.E.M. use Loctite 271 on nut each time.

This (these) spacer washer(s) must be used as shown to ensure damper rod nut does not bottom out or contact shaft threads.

Rebound valve stopper with round edge facing nut.

NOTE: Rebound shim stack must not reach into threads of damper shaft. Spacer under damper shaft nut is used to prevent damper shaft nut from bottoming on threads.

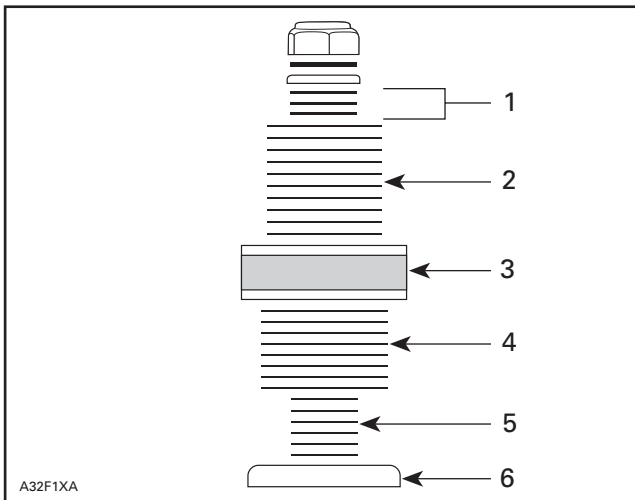

1. Rebound dampening shim pack
2. Rebound dampening shim pack
3. Piston
4. Compression dampening shim pack
5. Compression dampening shim pack
6. Stopper

If the seal carrier assembly is replaced, use seal pilot to guide seal over damper shaft. Lubricate seal carrier guide pilot before use.

CAUTION: Failure to use seal pilot will result in seal damage.

Reassemble damper rod assembly, taking care to properly assemble shim packs as required for your dampening needs. Ensure that the shaft piston is installed with the slits/larger intake holes facing the rebound shim stack.

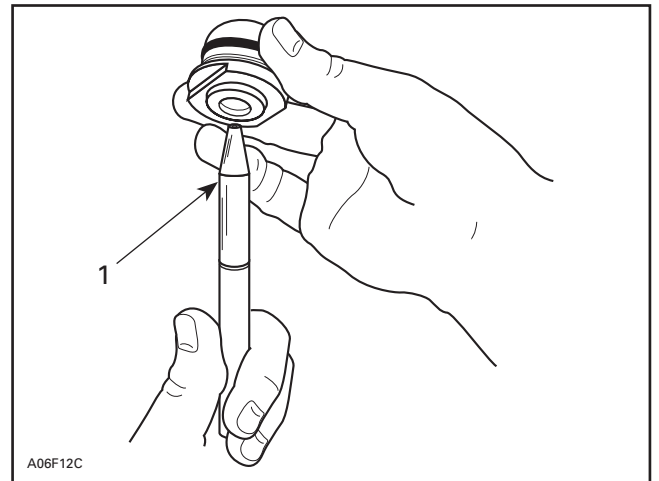

1. Seal guide (P/N 529 035 728)

If floating piston has been removed, reinstall floating piston into damper body (ensure that valve core has been removed). Use Molykote G-n paste (P/N 711 297 433) to ease O-ring past damper body threads with floating piston guide.

CAUTION: Failure to install IFP correctly could result in shock damage.

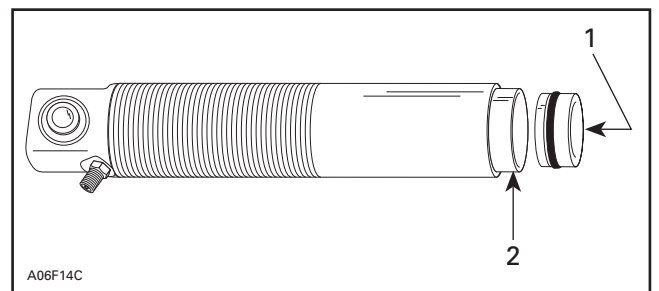

1. Push (slowly) by hand
2. Floating piston guide

NOTE: Lubricate inside of piston guide with Molykote G-n paste (P/N 711 297 433).

Install floating piston to the proper depth (190 mm (7.5 in)).

Section 07 REAR SUSPENSION

Subsection 02 (SC-10 II SUSPENSION)

On all HPG take apart shocks, the floating piston is installed hollow side up.

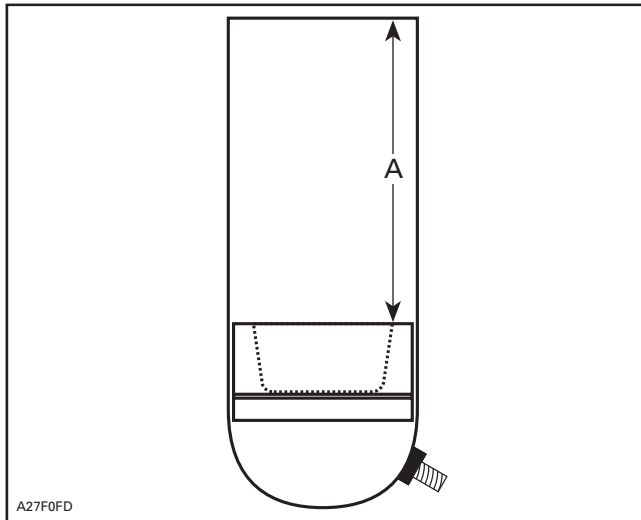

A. Installation distance for floating piston installation

SHOCK P/N	INSTALLATION DISTANCE OF FLOATING PISTON mm
503 189 745	130
503 189 678	130
503 189 491	130
503 189 610	130
503 189 279	130
503 189 528	130
503 189 076	130
503 189 677	183
503 189 077	183
503 189 492	183
503 189 609	190
503 189 280	190
503 189 527	183

NOTE: If the floating piston is installed too far into the damper body, light air pressure through valve (with core removed) will move piston outward.

NOTE: Reinstall valve core after IFP has been installed at correct height and before adding oil.

WARNING

Whenever using compressed air exercise extreme caution, cover damper opening with shop cloth to reduce chance of possible injury.

CAUTION: Moisture laden compressed air will contaminate the gas chamber and rust floating piston.

WARNING

Always wear protective eye wear whenever using compressed air.

Fill the shock with Bombardier HPG shock oil (P/N 293 600 035) to approximately 10 mm (.393 in), from the base of seal carrier threads.

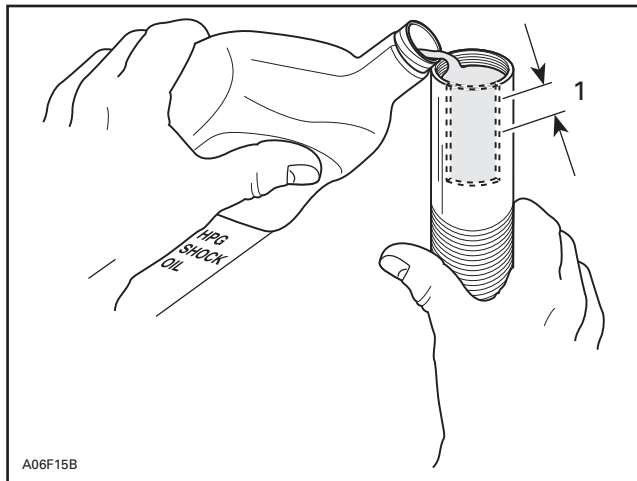

1. Fill to 10 mm (.393 in)

NOTE: Although we do not measure the exact amount of oil added to the damper, approximately 252 mL (8.52 oz. U.S.) will be used.

Section 07 REAR SUSPENSION

Subsection 02 (SC-10 II SUSPENSION)

Carefully insert damper rod into the damper body. Lightly oil damper piston seal ring with shock oil to ease installation.

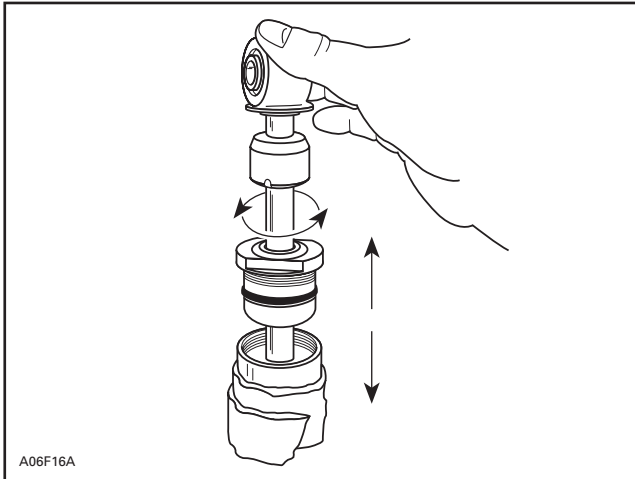

NOTE: Some shock oil will overflow when installing damper. Wrap damper with shop cloth to catch possible overflow oil.

CAUTION: Use care when passing piston into damper body at damper body threads.

Slight oscillation of damper rod may be required to allow piston to enter damper body bore.

Slowly push piston into damper body. Slight up and down movement may be required to allow all air to pass through piston assembly. The gentle tapping of a small wrench, on the shock eye, may help dislodge air trapped in the submerged piston. Be careful not to drive the shaft any deeper into the oil than is necessary to just cover the shim stack.

NOTE: Fast installation of the damper rod may displace the floating piston from its original position. This must not occur if the damper is expected to perform as designed.

With damper rod piston into oil, TOP OFF damper oil volume. Oil level should be to damper body thread base.

Seal carrier assembly can now be threaded into damper body. This should be done slowly to allow weepage of oil and to minimize IFP displacement. Torque seal carrier to 90 to 100 N•m (66 to 74 lbf•ft). After the seal carrier is fully in place avoid pushing the shaft into the body until the nitrogen charge is added.

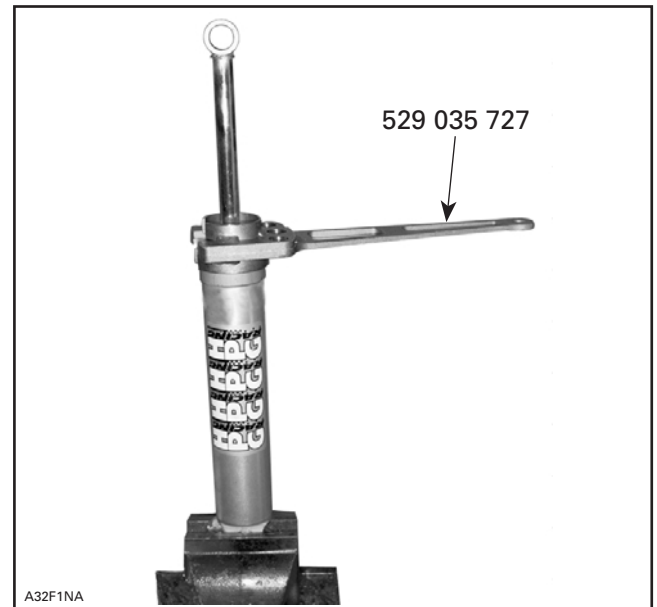

When removing and retightening the tire valve acorn nut use minimal torque. When the cap is over tightened and subsequently removed it may prematurely break the seal of the tire valve to the shock body and cause a loss of nitrogen charge without being noticed. If you suspect this has happened then recharge the shock as a precaution. Inspect the valve cap before installation to ensure that the internal rubber gasket is in its proper position.

Section 07 REAR SUSPENSION

Subsection 02 (SC-10 II SUSPENSION)

Adding Gas Pressure

Nitrogen (N_2) can now be added to damper body.

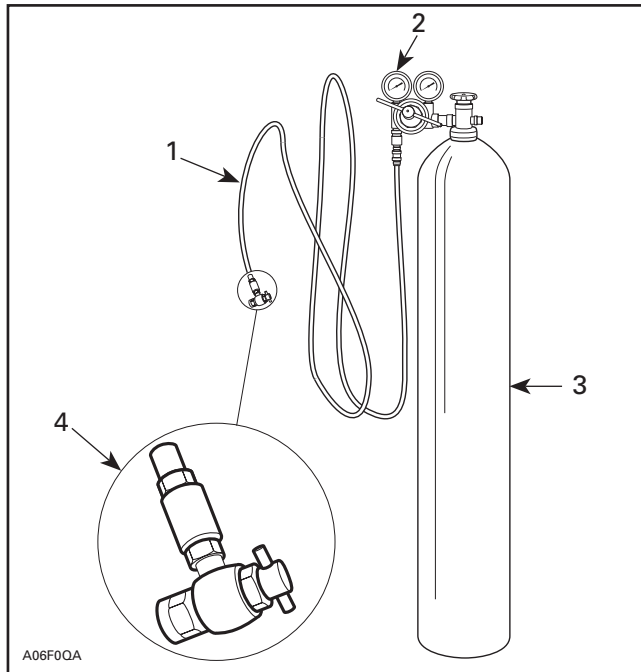

1. High pressure hose
2. 2 stage regulator, delivery pressure range 2070 kPa (300 PSI)
3. High pressure cylinder filled with industrial grade nitrogen
4. Valve tip (P/N 529 035 570) permanently installed

NOTE: Never substitute another gas for nitrogen. Nitrogen has been selected for its inert qualities and will not contaminate the gas chamber of the shock.

Preset your pressure regulator to 2070 kPa (300 PSI) nitrogen (N_2), this gas pressure will restore the correct pressure for your damper.

CAUTION: Do not exceed the recommended pressure values.

⚠ WARNING

Whenever working with high pressure gas, use eye wear protection. Never direct gas pressure toward anybody.

Use appropriate inflation tool.

Needle Valve Type Shock

Insert needle type shock tool (P/N 529 035 614) very slowly into rubber of needle valve.

Rubber may pop out of needle valve when inserting tool needle. If so, remove valve core and rubber then, reinstall rubber with its larger diameter last.

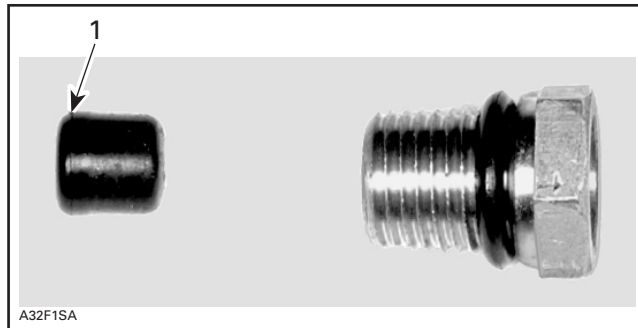

1. Larger diameter

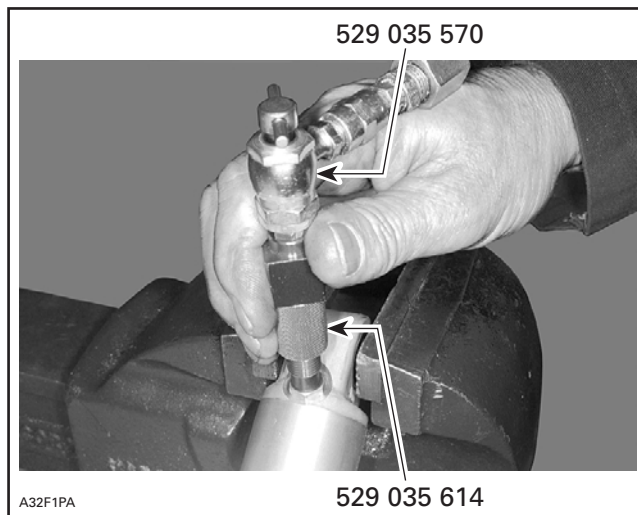

BOTH INFLATION TOOLS ARE USED ON NEEDLE VALVE TYPE SHOCK

All Shock Types

NOTE: Carefully inspect damper for gas or oil leaks. Any leaks must be corrected before continuing.

Damper gas pressure cannot be confirmed by using a pressure gauge. The volume of gas in the shock is very small, and the amount lost during gauge installation will lower the pressure too much and require refilling.

After recharging is complete the rebuilt shock should be bench-tested. Stroke the shock to ensure full travel and smooth compression and rebound action. If the shaft moves in or out erratically this could indicate too much air is trapped inside. If the shaft will not move or has partial travel then it may be hydraulically locked. In either event the shock must be rebuilt again. Pay particular attention to the placement of the IFP, quantity of oil and shim stack/piston assembly.

INSTALLATION

Install assembled suspension into track with front portion first.

Insert rear portion of suspension into track.

Bolt front arm and rear arm.

Adjust track tension.

RIDE ADJUSTMENT

Refer to *Operator's Guide*.

LUBRICATION

Lubricate front and rear arms at grease fittings using synthetic grease (P/N 413 711 500).

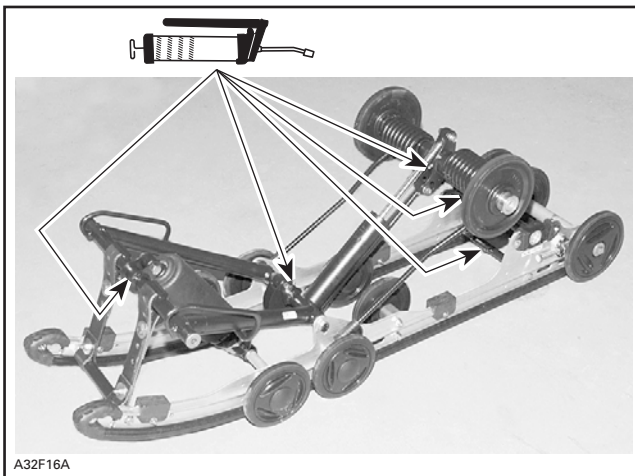

SC-10 II: 5 GREASE FITTINGS

SC-10 MOUNTAIN SUSPENSION

All Summit Models

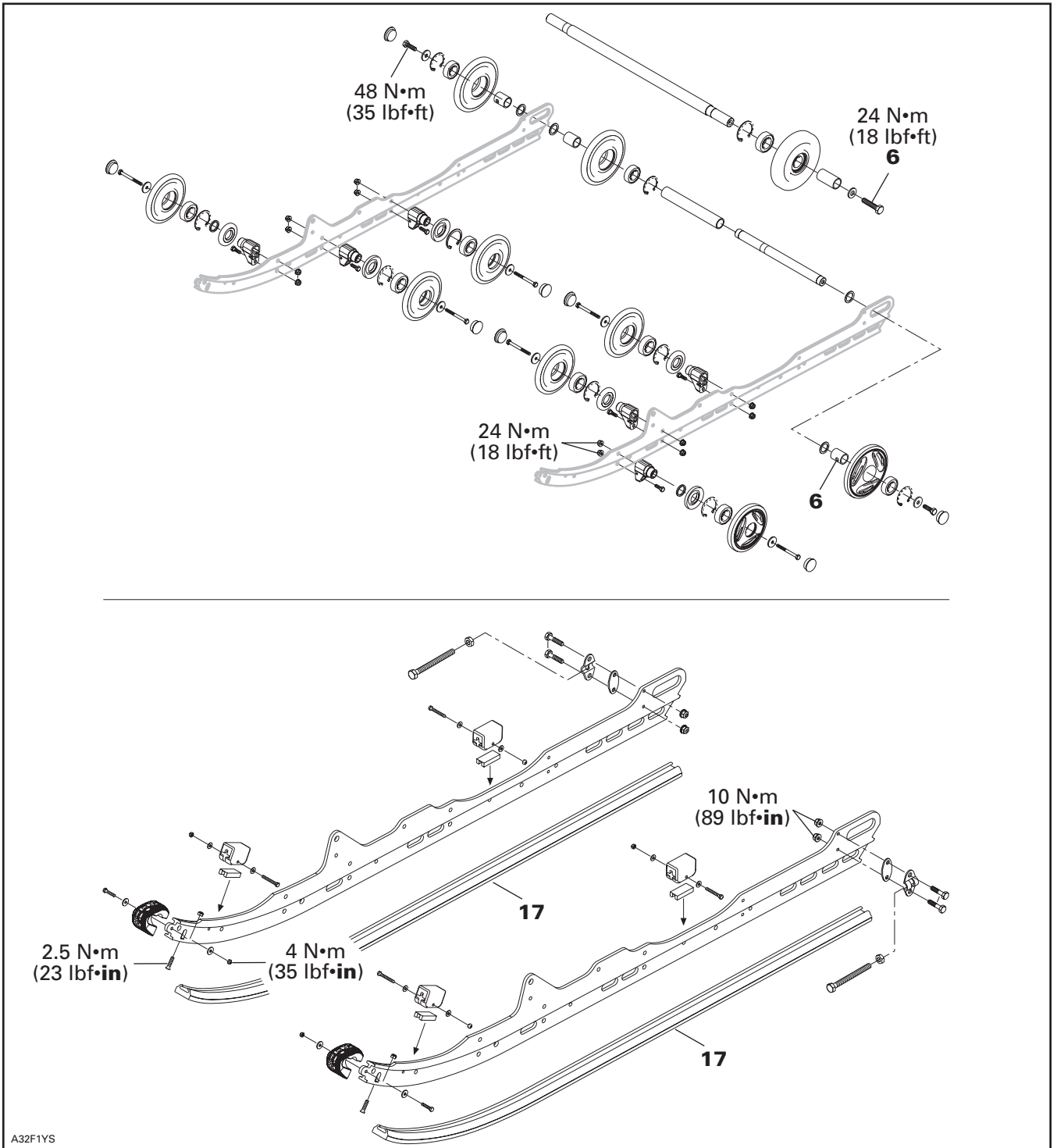

Section 07 REAR SUSPENSION

Subsection 03 (SC-10 MOUNTAIN SUSPENSION)

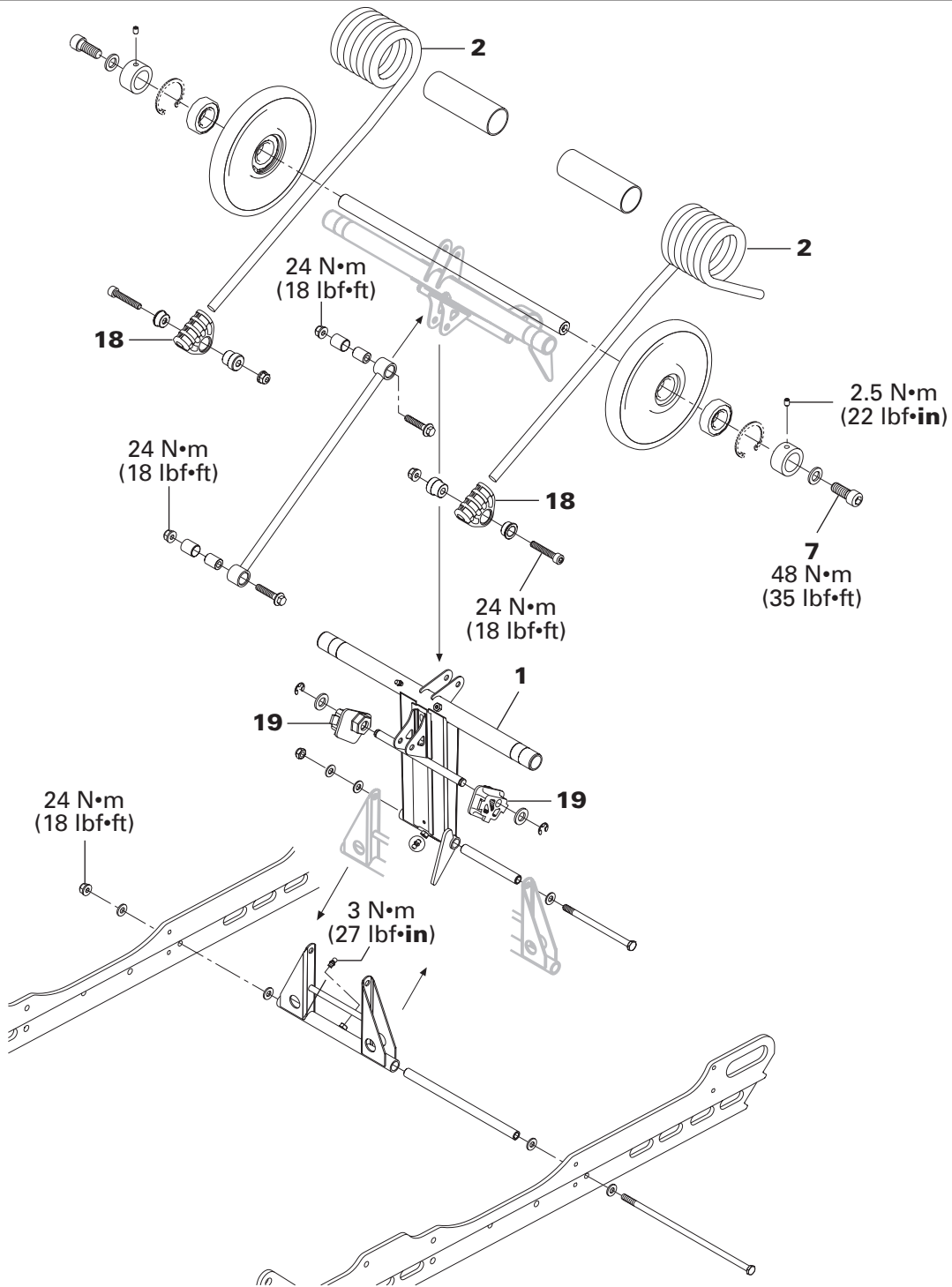

A32F1ZS

Section 07 REAR SUSPENSION

Subsection 03 (SC-10 MOUNTAIN SUSPENSION)

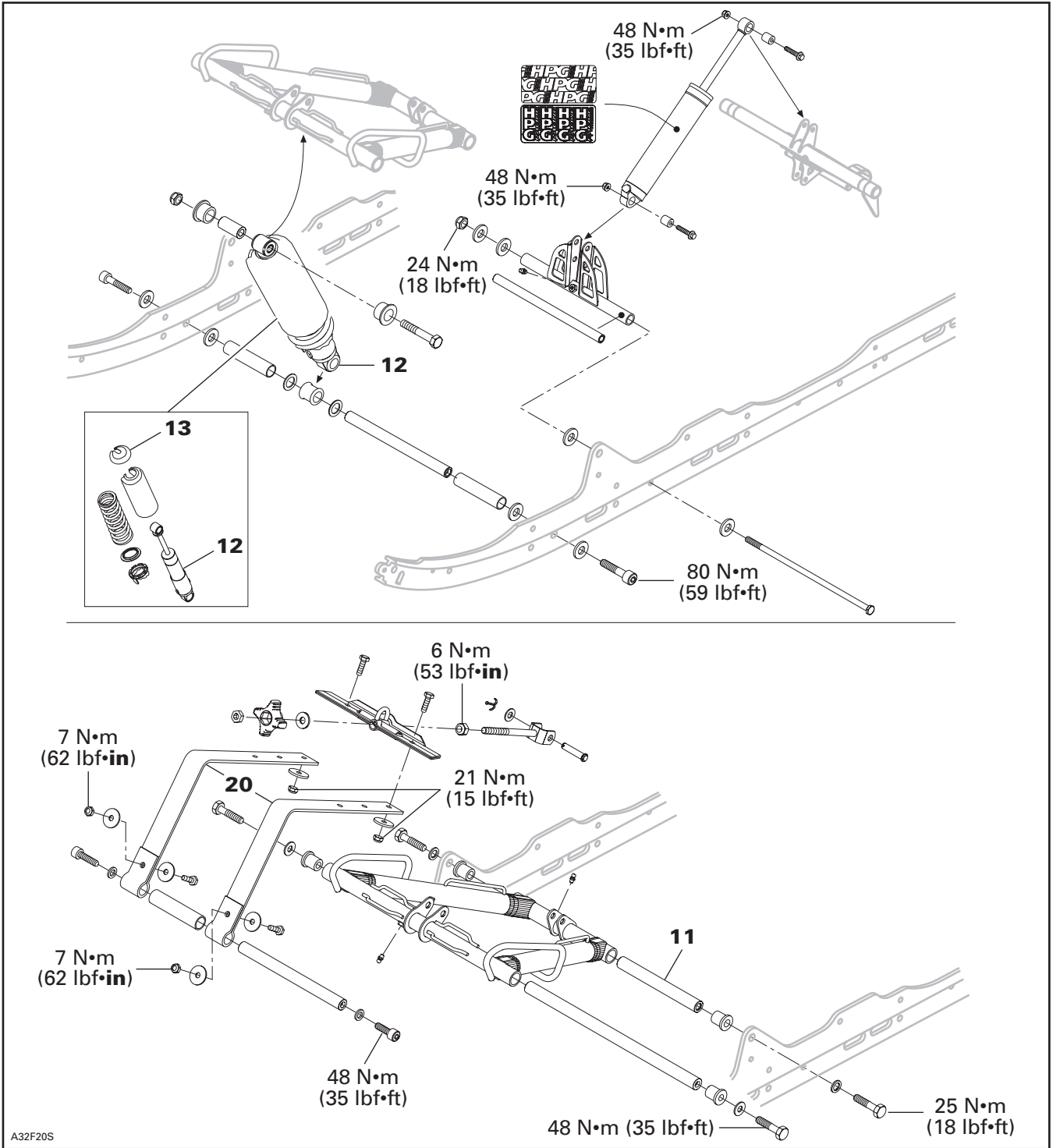

Section 07 REAR SUSPENSION

Subsection 03 (SC-10 MOUNTAIN SUSPENSION)

COMPONENT REMOVAL AND INSTALLATION

Lift rear of vehicle and support it off the ground.

21, Rear Axle

Remove screw on rear axle on side of offset wheel.

Completely loosen track tension.

Pull out rear axle from opposite side of offset inner wheel.

At assembly, align spacer hole with adjusting bolt.

Make sure to reinstall washer on each side of runner.

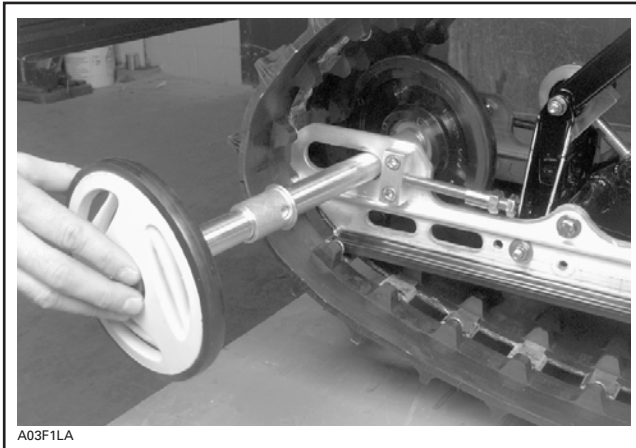

TYPICAL

15, Rear Shock

Lift rear of vehicle.

Slightly turn adjusting cam to expose spring end. Using spring installer (P/N 529 005 000), remove left spring from adjusting cam.

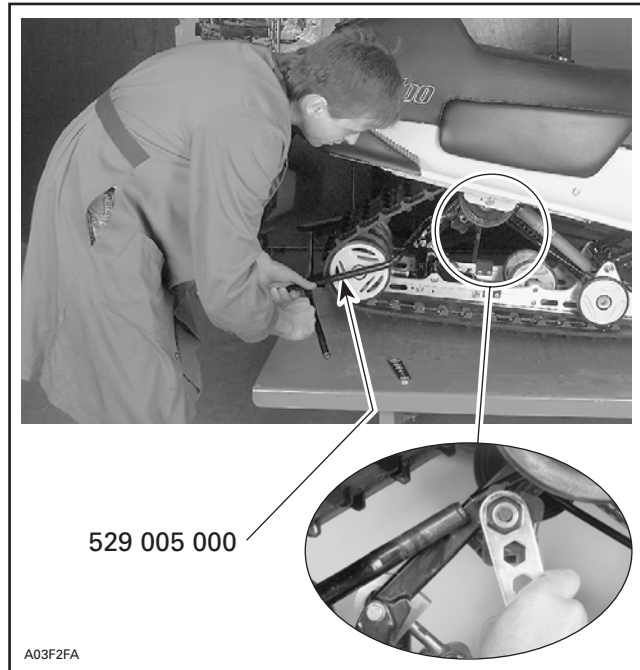

TYPICAL

Remove nut on top end of shock.

Remove nut on bottom end of shock. Pry up shock bottom end to ease removing bolt (gas shock only). See installation illustration below.

Installation is reverse of removal procedure. To easily compress gas shock absorber, use a pry bar and locking pliers as a stopper.

CAUTION: Take care not to damage grease fitting.

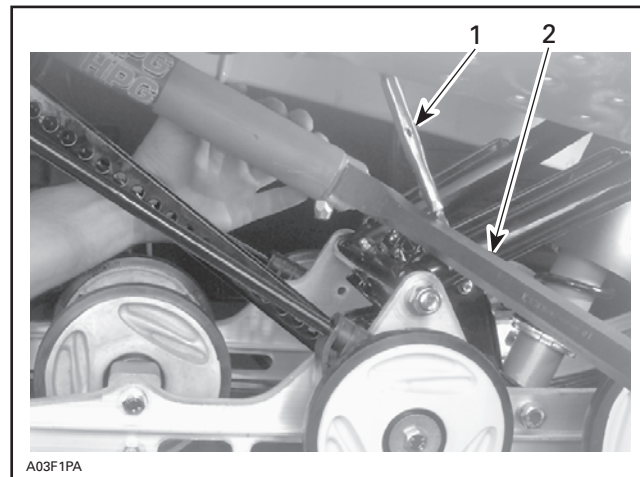

TYPICAL

1. Locking pliers
2. Pry bar

12, Front Shock

Unfasten one end of stopper strap(s).
Unbolt shock and remove it.

2, Rear Spring

Remove spring ends from adjusting cams.
Unbolt rear arm top axle from chassis.
Unscrew set screws from locking ring at each end of top axle.
Remove spacers and top idler wheels.
Remove springs.

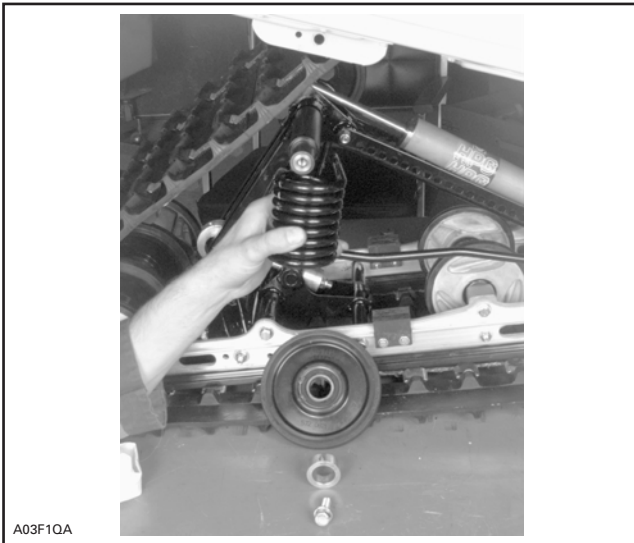

TYPICAL

At reassembly, respect THIS SIDE OUT inscription on wheel.

SUSPENSION ASS'Y REMOVAL

19, Cam

Decrease spring preload by turning cams accordingly.
Lift rear of vehicle and support it off the ground.
Loosen track tension.
Remove rear arm top axle screws **no. 7** from chassis.

6,7, Self-Locking Screws

CAUTION: These self-locking screws must always be replaced by new ones everytime they are removed.

NOTE: To prevent axle from turning when unscrewing self-locking screws, proceed as follows:

- Remove one self-locking screw then install a 10 mm shorter non-self-locking one in place. Torque as specified in exploded view.
- Remove the opposite self-locking screw.
- Remove the temporary installed non-self-locking screw.
- If it doesn't work, heat bolt head to melt thread-locker.

Unscrew center idler wheel axle from tunnel then remove.

Lift rear of vehicle at least 1 m (3 ft).



TYPICAL

A. At least 1 m (3 ft)

Remove both self-locking screws **no. 6** retaining front arm to tunnel.

Remove suspension.

Section 07 REAR SUSPENSION

Subsection 03 (SC-10 MOUNTAIN SUSPENSION)

DISASSEMBLY AND ASSEMBLY

Inspect track thoroughly before reinstalling suspension. Refer to TRACK.

1, Rear Arm

At installation, rear arm stroke limiter must be on rear side.

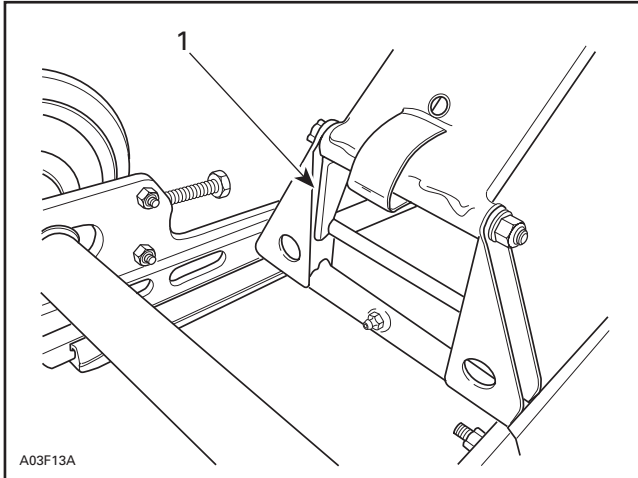

1. Stroke limiter on rear side

10, Outer Bushing

At installation, hole must face adjustment screw.

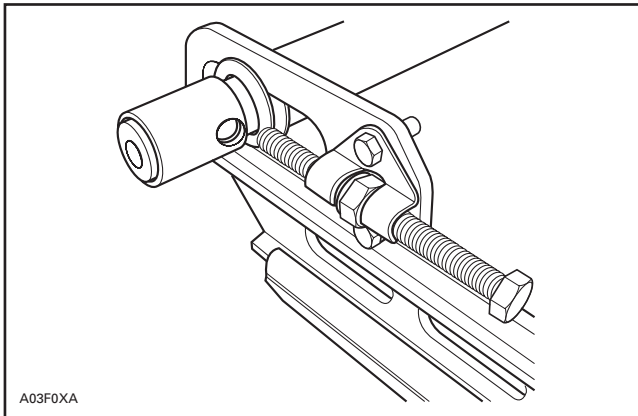

A03F0XA

11, Axle

Note position of axles at disassembly. Axles with a paint stripe serve as idler wheel axles. These are more precise than those used as pivot axles. Idler wheel axles can be used as pivot axles but the opposite is not true.

12,13, Front Shock and Spring Stopper

Use shock spring remover (P/N 529 035 504) and put it in a vise. Mount shock in it and turn shock so that spring coils matched spring compressor.

Close and lock bar. Adjust handle horizontal by changing position of clevis pin.

Push down on handle until it locks. Remove spring stopper then release handle.

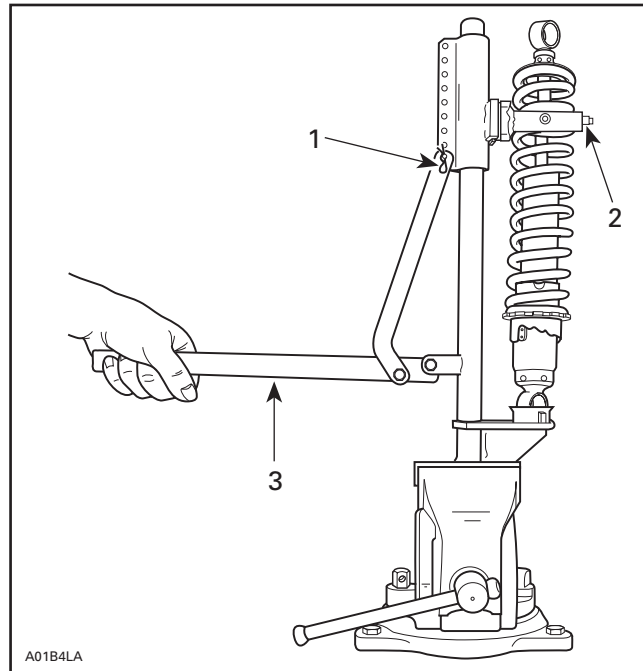

1. Clevis pin
2. Bar
3. Handle horizontal

20, Stopper Strap

Inspect strap for wear or cracks, bolt and nut for tightness. If loose, inspect hole for deformation. Replace as required. Torque nuts as specified in exploded view.

17, Slider Shoe

Molding line is the wear limit indicator.

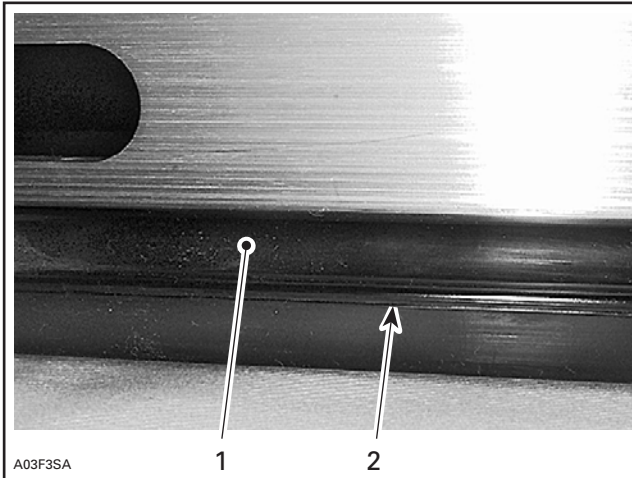

TYPICAL

1. Slider shoe
2. Molding line (wear limit indicator)

Replace slider shoes when wear limit is reached.

CAUTION: Slider shoes must always be replaced in pairs.

18, Spring Support

CAUTION: To avoid track damage, spring supports must be mounted upward.

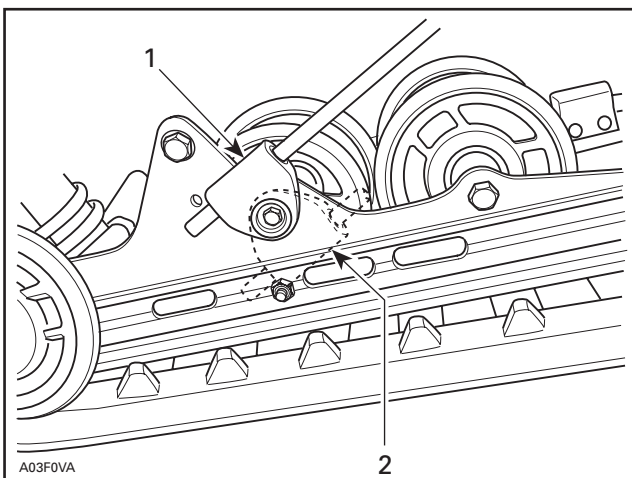

RIGHT SIDE SHOWN

1. Right position: upward
2. Wrong position

SHOCK ABSORBER INSPECTION

All Models Equipped with Hydraulic Shock

NOTE: Hydraulic shocks are black painted.

Secure the shock body end in a vise with its rod upward.

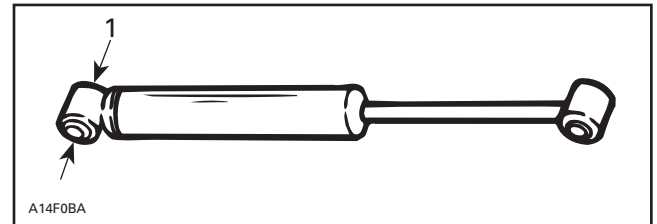

1. Clamp

CAUTION: Do not clamp directly on shock body.

Examine each shock for leaks. Extend and compress the piston several times over its entire stroke. Check that it moves smoothly and with uniform resistance with its rod upward.

Pay attention to the following conditions that will denote a defective shock:

- A skip or a hang back when reversing stroke at mid travel.
- Seizing or binding condition except at extreme end of either stroke.
- Oil leakage.
- A gurgling noise, after completing one full compression and extension stroke.

Renew if any faults are present.

All Models Equipped with Gas Pressurized Shock

NOTE: Gas pressurized shocks are light gray or purple painted, or bare aluminum.

Gas shock can be inspected as follows:

Because of gas pressure, strong resistance is felt when compressing shock. When released, the shock will extend unassisted. Renew as required.

If suspecting an internal gas leak between oil chamber and gas chamber, check shock as follows:

Install shock in a vise clamping on its bottom eyelet with its rod upward.

Let it stand for 5 minutes.

Section 07 REAR SUSPENSION

Subsection 03 (SC-10 MOUNTAIN SUSPENSION)

Completely push down the shock rod then release.

Rod must come out at a steady speed. If speed suddenly increases particularly at end of extension, replace shock.

All Types of Shock

If suspecting a frozen shock proceed as follows:

Place shock in a freezer (temperature below 0°C (32°F)) for 4 hours.

Push down on rod and note its resistance. If shock is frozen it will be impossible or almost impossible to compress it.

HPG T/A SHOCK SERVICING

Refer to SC-10 II SUSPENSION.

INSTALLATION

Install assembled suspension into track with front portion first.

Insert rear portion of suspension into track.

Bolt front arm, rear arm then center top idler wheel axle.

Adjust track tension.

RIDE ADJUSTMENT

Refer to *Operator's Guide*.

LUBRICATION

Lubricate front and rear arms at grease fittings using synthetic grease (P/N 413 711 500).

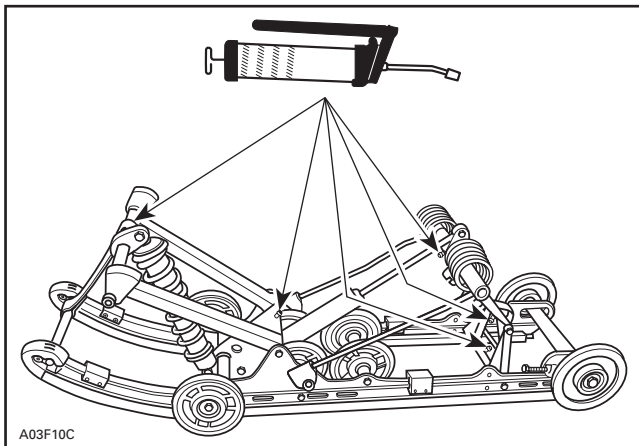

TYPICAL — 5 GREASE FITTINGS

DRIVE AXLE

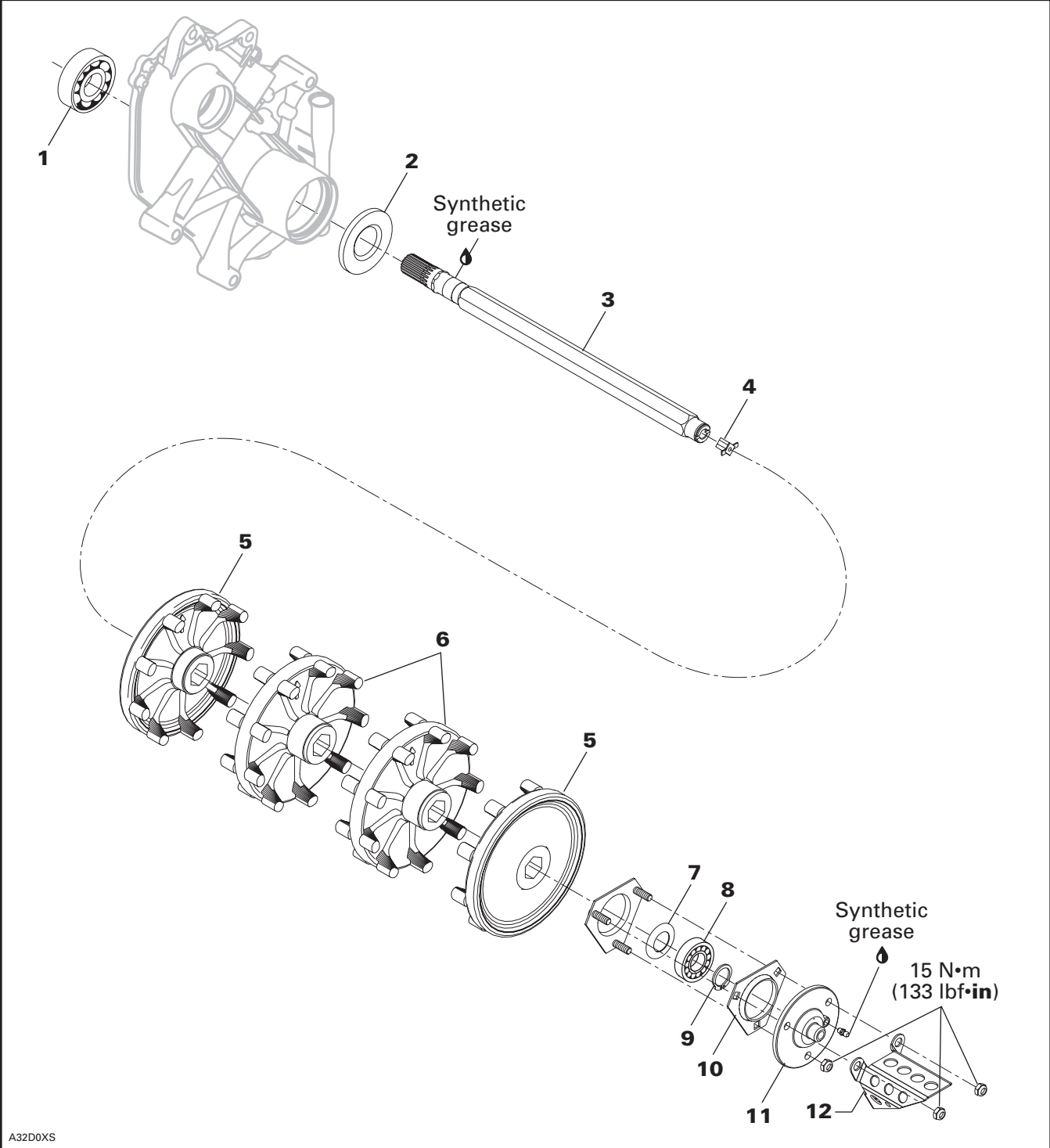

A32D0XS

Section 07 REAR SUSPENSION

Subsection 04 (DRIVE AXLE)

REMOVAL

According to model, drain oil from chaincase or gearbox. Remove chaincase or gearbox cover. Release drive chain tension.

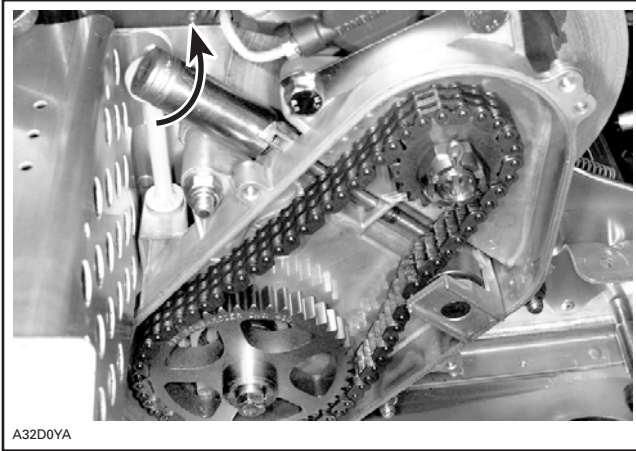

Raise and block rear of vehicle off the ground. Remove suspension. Refer to proper subsection. Track can be held in tunnel using a rod in place of center idler wheel axle.

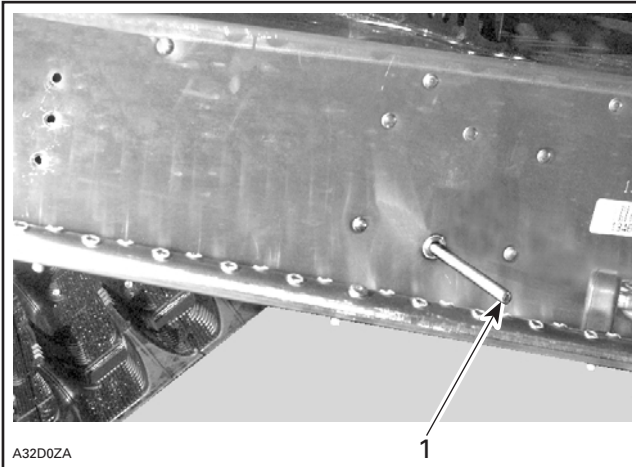

1. Rod

Remove cable protector no. 12, plastic cover no. 11, outer flange no. 10 and circlip no. 9 from left side.

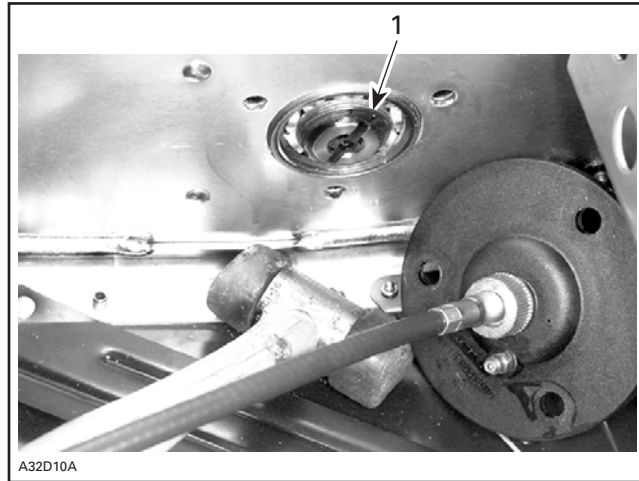

1. Circlip

Apply parking brake.

Remove chain and sprockets then circlip from right side.

Release drive axle sprocket from track and at the same time, push the drive axle no. 3 toward the right side. Drive axle bearing no. 1 in chaincase or gearbox will fall off.

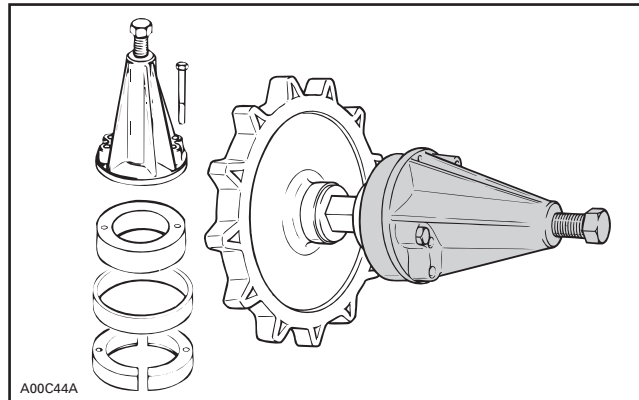

TYPICAL

5,6, Sprocket and Half-Sprocket

To remove press fit sprockets, use a press and a suitable support as illustrated.

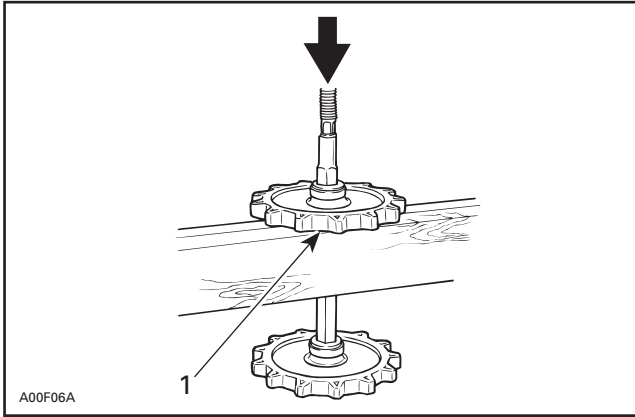

TYPICAL

1. Support sprocket near hub

ASSEMBLY

3,5,6, Drive Axle and Sprocket

To assemble press fit sprockets, use a press and a suitable pipe as illustrated. Sprockets must be assembled according to the following dimensions.

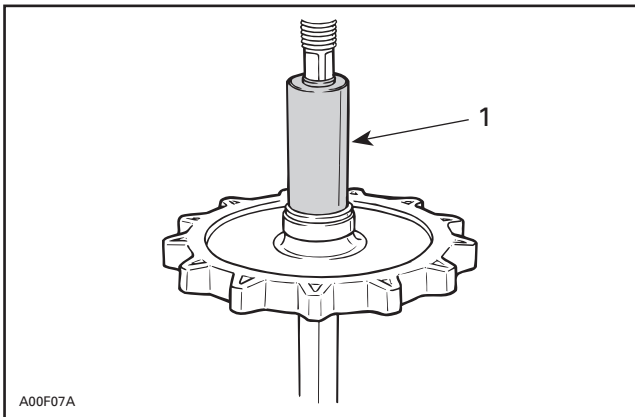

TYPICAL

1. Pipe

ZX Series

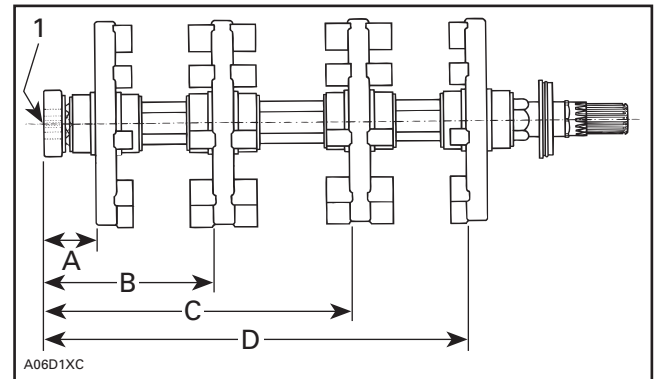

1. Measure from end of drive axle

- A. 47.3 mm (1.862 in)
- B. 149.8 mm (5.898 in)
- C. 272.8 mm (10.740 in)
- D. 375.3 mm (14.776 in)

Ensure to align indexing marks of each sprocket when assembling.

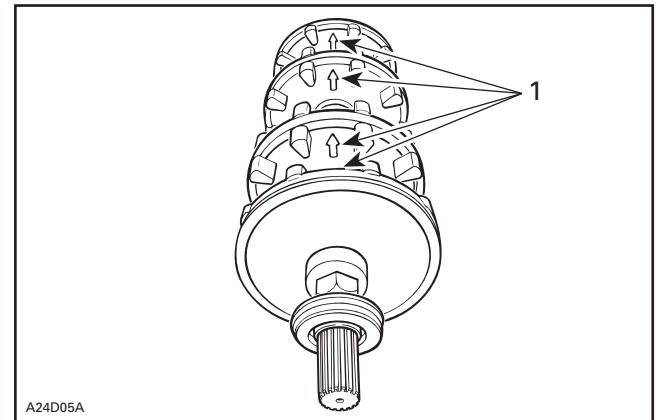

TYPICAL

1. Indexing marks aligned

The maximum desynchronization for the sprockets is 1.5 mm (1/16 in).

To check this tolerance, place axle assembly on a plane surface and measure the gap between sprocket tooth and surface.

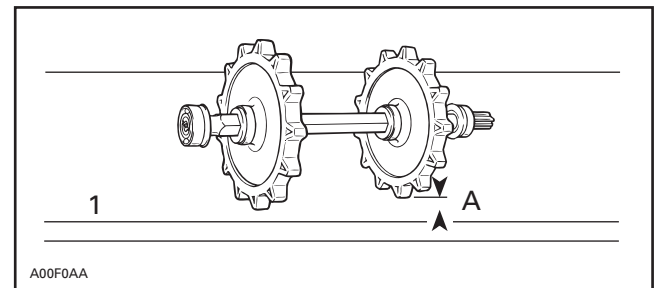

TYPICAL

- 1. Plane surface
- A. 1.5 mm (1/16 in) MAXIMUM

Section 07 REAR SUSPENSION

Subsection 04 (DRIVE AXLE)

CAUTION: The same sprocket must not be pressed twice on the axle. If synchronization is found to be defective, use a new sprocket.

7, Bearing Protector

At assembly, flat side of bearing protector must be against bearing.

8, Bearing

Always push bearing by inner race.

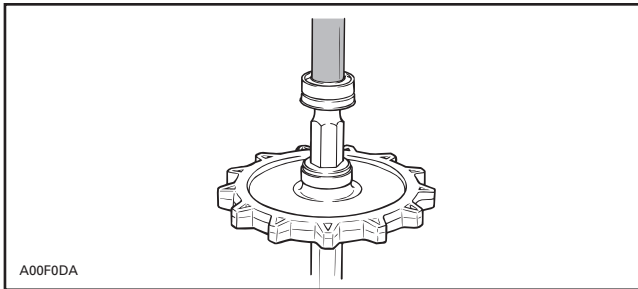

TYPICAL

The bearing no. 8 must have its shield facing the sprocket.

The bearing no. 1 must have its shield facing right side (cover).

LUBRICATION

Lubricate end housing bearing with synthetic grease (P/N 413 711 500).

ADJUSTMENT

Sprocket/Track Alignment

CAUTION: Do not temper with sprocket/track alignment if frame or suspension is damaged.

Sprockets might be repositioned to fit lugs without removing drive axle.

Use drive axle sprocket adjuster kit (P/N 861 725 700).

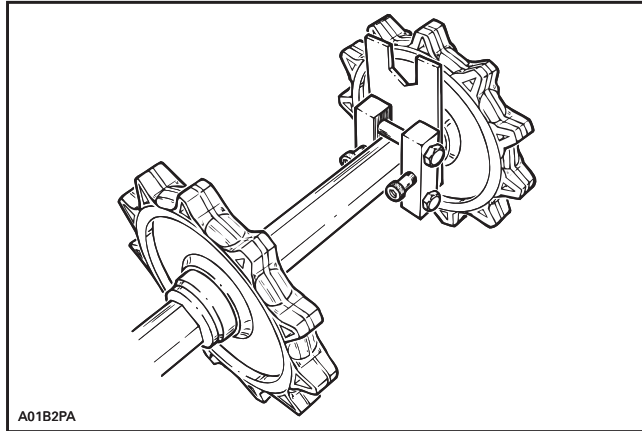

TYPICAL

TRACK

TRACK TYPE APPLICATION

Refer to TECHNICAL DATA.

GENERAL

This section gives guidelines for track removal. Some components require more detailed disassembly procedures. In these particular cases, refer to the pertaining section in this manual.

INSPECTION

Visually inspect track for:

- cuts and abnormal wear
- broken rods
- broken or missing track cleats.

If track is damaged or rods are broken, replace track. For damaged or missing cleats, replace by new ones, using cleat remover (P/N 529 028 700). Use narrow-cleat installer (P/N 529 008 500).

WARNING

Do not operate a snowmobile with a cut, torn or damaged track.

REMOVAL

Remove the following parts:

- speedometer cable
- muffler
- chaincase or gearbox cover
- rear suspension
- drive axle seal
- end bearing housing
- sprockets and chain
- drive axle
- track.

INSTALLATION

Reverse the removal procedure.

NOTE: When installing the track, respect rotation direction indicated by an arrow on track thread.

Check sprocket/track alignment as described in DRIVE AXLE.

Track Tension and Alignment

Track tension and alignment are inter-related. Do not adjust one without checking the other. Track tension procedure must be carried out prior to track alignment.

Tension

Lift the rear of vehicle and support with a mechanical stand. Allow the slide to extend normally. Check the gap half-way between front and rear idler wheels. Measure between slider shoe and bottom inside of track.

When using the track tension gauge (P/N 529 021 500), slide U shape extrusion to proper deflection.

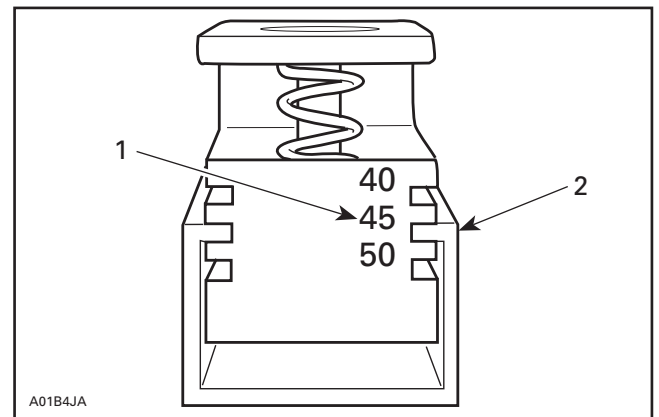

1. Example: 45 mm
2. Extrusion

Insert pre-setted gauge between slider shoe and track. Allow gauge to settle by forcing track up and down. Track tension is as specified when edge of gauge reaches line.

Section 07 REAR SUSPENSION

Subsection 05 (TRACK)

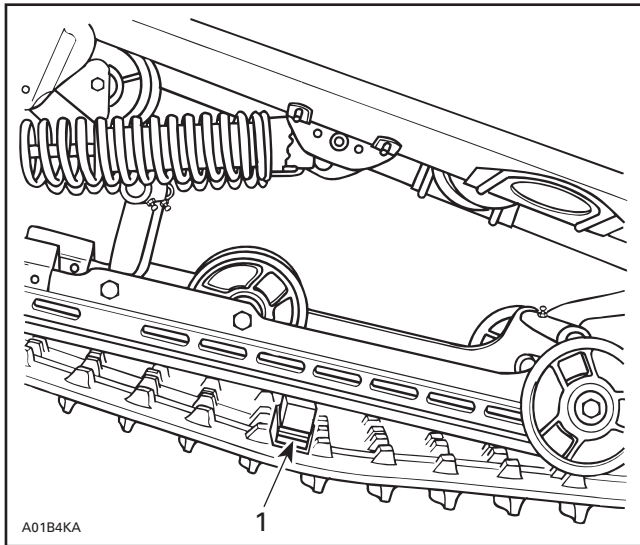

TYPICAL

1. Line

NOTE: Lightly oil track tension gauge center pin to avoid sticking.

All Models

Refer to TECHNICAL DATA for proper tension values.

CAUTION: Too much tension will result in power loss and excessive stress on suspension components. If too loose, the track will have a tendency to thump.

To adjust, loosen the rear idler wheel retaining screws then loosen or tighten the adjuster bolts located on the inner side of the rear idler wheels.

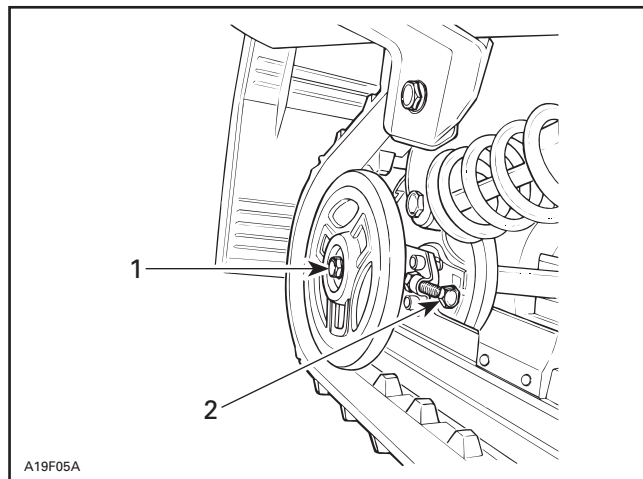

TYPICAL

1. Retaining screw
2. Adjuster bolt

Alignment

WARNING

Before checking track tension, ensure that the track is free of all particles which could be thrown out while it is rotating. Keep hands, tools, feet and clothing clear of track. Ensure no one is standing in close proximity to the vehicle.

All Models

With rear of vehicle supported off the ground, start engine and allow the track to rotate **slowly**.

Check that the track is well centered; equal distance on both sides between edges of track guides and slider shoes.

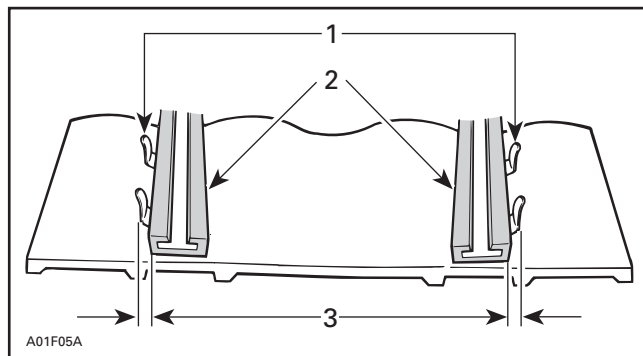

1. Guides
2. Slider shoes
3. Equal distance

WARNING

Before checking track alignment, ensure that the track is free of all particles which could be thrown out while track is rotating. Keep hands, tools, feet and clothing clear of track.

To correct, stop engine then tighten the adjuster bolt on side where guides are farthest to slide. Re-check alignment.

Section 07 REAR SUSPENSION

Subsection 05 (TRACK)

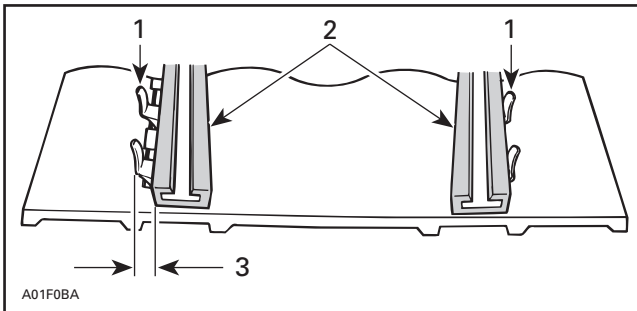

1. Guides
2. Slider shoes
3. Tighten on this side

NOTE: Torque retaining screw to 48 N•m (35 lbf•ft) after adjustment.

Tighten the idler wheel retaining screws.

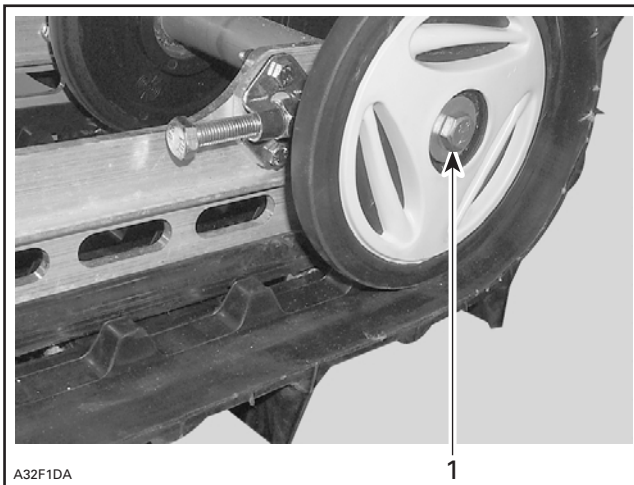

TYPICAL

1. Retighten to 48 N•m (35 lbf•ft)

Restart engine, rotate track **slowly** and recheck alignment.

Track Cleat

Removal

- Raise rear of vehicle off the ground and lift snow-guard then rotate track to expose a cleat to be replaced.
- Using track cleat remover (P/N 529 028 700) for all models.

Installation

NOTE: Keep the same pitch between guide cleats.

- Place new cleat in position and using narrow track cleat installer (P/N 529 008 500) bend cleat then push tabs into rubber.

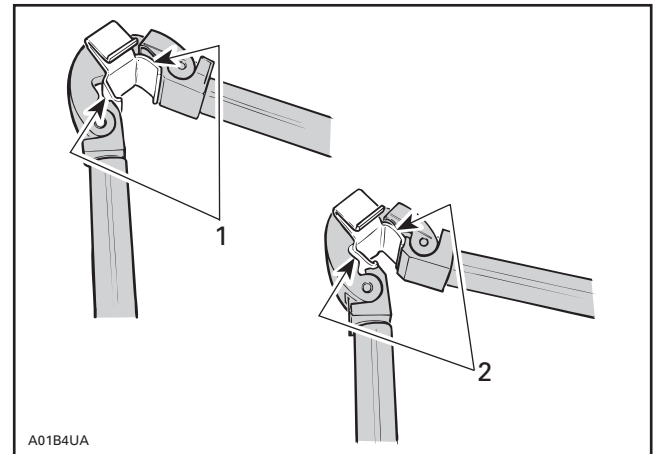

TYPICAL

1. First step
2. Second step (to push tabs into rubber)