

TABLE OF CONTENTS

DRIVE BELT	05-02-1
2001 APPLICATION CHART	05-02-1
INSPECTION	05-02-1
ROTATION DIRECTION	05-02-1
DRIVE BELT DEFLECTION MEASUREMENT	05-02-2
DEFLECTION ADJUSTMENT	05-02-3

DRIVE PULLEY	05-03-1
TRA	05-03-1
GENERAL	05-03-2
REMOVAL	05-03-2
DISASSEMBLY	05-03-2
CLEANING	05-03-3
INSPECTION	05-03-4
ASSEMBLY	05-03-4
INSTALLATION	05-03-7
DRIVE PULLEY ADJUSTMENT	05-03-8

DRIVEN PULLEY	05-04-1
REMOVAL	05-04-2
DISASSEMBLY	05-04-2
CLEANING	05-04-2
INSPECTION	05-04-3
ASSEMBLY	05-04-3
INSTALLATION	05-04-3
ADJUSTMENT	05-04-3

PULLEY DISTANCE AND ALIGNMENT	05-05-1
GENERAL	05-05-1
GENERAL PROCEDURE	05-05-1
PULLEY ALIGNMENT AND DISTANCE SPECIFICATIONS CHART	05-05-2

BRAKE	05-06-1
HYDRAULIC DISC BRAKE	05-06-1
REMOVAL	05-06-2
DISASSEMBLY	05-06-2
CLEANING	05-06-2
INSPECTION	05-06-2
INSTALLATION	05-06-2
ADJUSTMENT	05-06-3
BLEEDING	05-06-3

Section 05 TRANSMISSION

Subsection 01 (TABLE OF CONTENTS)

CHAINCASE	05-07-1
REMOVAL AND DISASSEMBLY	05-07-2
INSPECTION	05-07-2
GEAR RATIO MODIFICATION.....	05-07-2
INSTALLATION AND ASSEMBLY	05-07-3
DRIVE CHAIN ADJUSTMENT.....	05-07-3
ADJUSTMENT.....	05-07-4

GEARBOX	05-08-1
DISASSEMBLY	05-08-2
INSPECTION	05-08-3
ASSEMBLY	05-08-3
ADJUSTMENT.....	05-08-5
OIL CHANGE.....	05-08-5

DRIVE CHAIN	05-09-1
SILENT CHAIN	05-09-1

DRIVE BELT

2001 APPLICATION CHART

MODEL	PART NUMBER	WIDTH (NEW) ± 0.25 mm (.010 in)	MINIMUM WIDTH (WEAR LIMIT) mm (in)
All 493 and 593 engine equipped models except Summit 600	414 860 700	35.30 (1.390)	32.30 (1.272)
All 693 and 793 engine equipped models and Summit 600	417 300 127	36.35 (1.431)	33.35 (1.313)

INSPECTION

Inspect belt for cracks, fraying or abnormal wear (uneven wear, wear on one side, missing cogs, cracked fabric). If abnormal wear is noted, probable cause could be pulley misalignment, excessive RPM with frozen track, fast starts without warm-up period, burred or rusty sheave, oil on belt or distorted spare belt.

Check the drive belt width. Replace the drive belt if width is less than the minimum width recommended (see table above).

ROTATION DIRECTION

The maximum drive belt life span is obtained when the drive belt is installed as shown. This will ensure that correct direction of rotation is respected.

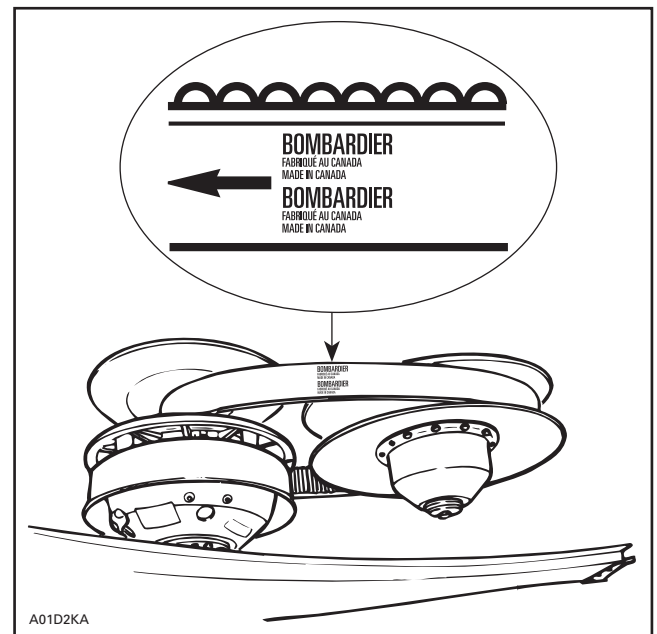

CORRECT

Section 05 TRANSMISSION

Subsection 02 (DRIVE BELT)

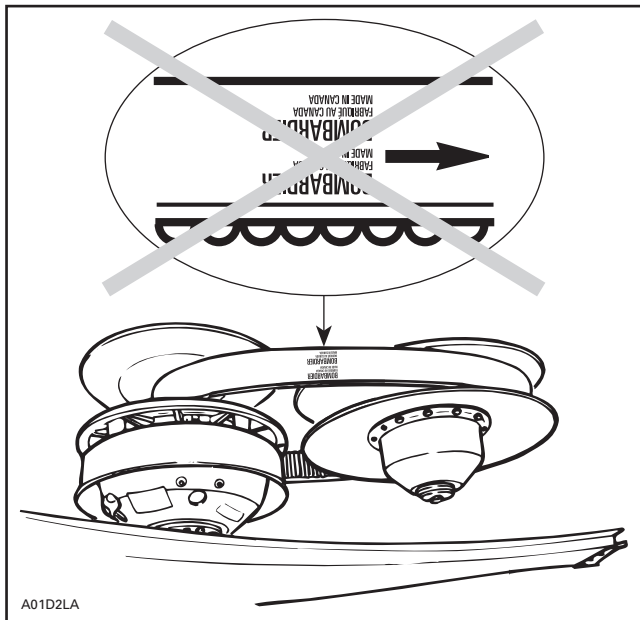

INCORRECT

NOTE: For used drive belt, mark and reinstall in the same position.

DRIVE BELT DEFLECTION MEASUREMENT

NOTE: The drive belt deflection measurement must be performed each time a new drive belt is installed.

NOTE: To obtain an accurate drive belt deflection measurement, it is suggested to allow a break-in period of 50 km (30 mi).

Before checking the belt deflection, ensure vehicle has the proper belt (refer to the *Application Chart*).

Adjust pulley distance and alignment. Refer to PULLEY DISTANCE AND ALIGNMENT.

To obtain maximum vehicle performance, the belt tension must be adjusted according to specifications shown in the accompanying chart.

MODEL	DEFLECTION mm (in)	FORCE kg (lb)	HEIGHT† OVER DRIVEN PULLEY
All models	32 ± 5 (1.260 ± .197)	11.5 (25)	0 - 1.5 mm (0 - 1/16 in)

† FOR REFERENCE ONLY

To Check Tension

Position a reference rule on drive belt.

Wooden Stick and Spring Scale Method

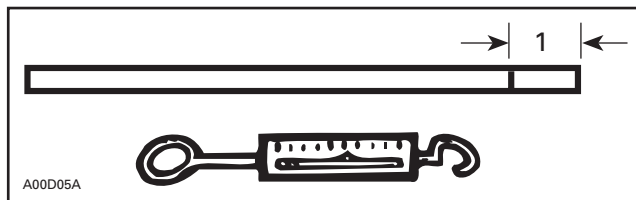

1. Mark specified deflection

Using spring scale and stick, apply specified force on drive belt halfway between pulleys as shown.

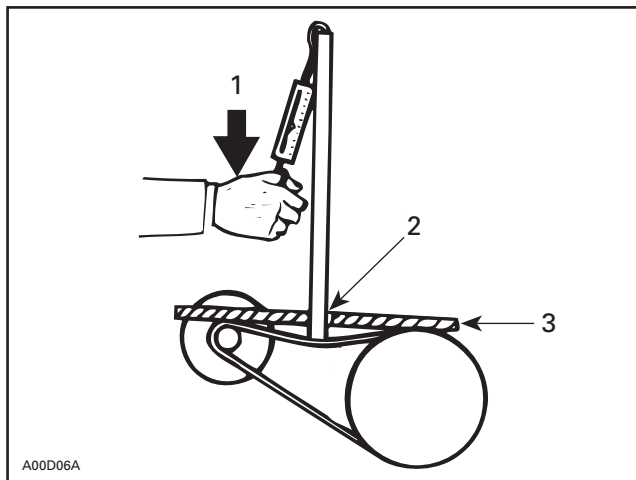

1. Force
2. Read deflection here
3. Reference rule

Or use the belt tension tester (P/N 414 348 200).

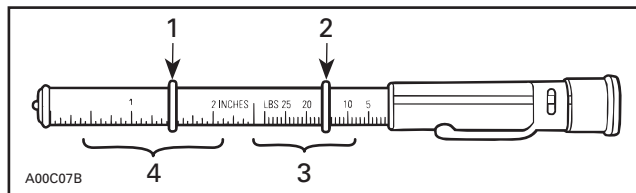

1. Lower O-ring
2. Upper O-ring
3. Force (read down)
4. Deflection (read up)

1. Slide lower O-ring of deflection scale to specified measure.
2. Slide upper O-ring to 0 (zero) on the force scale.

3. Apply pressure until lower O-ring is flush with edge of rule and read force on the upper scale at top edge of O-ring.

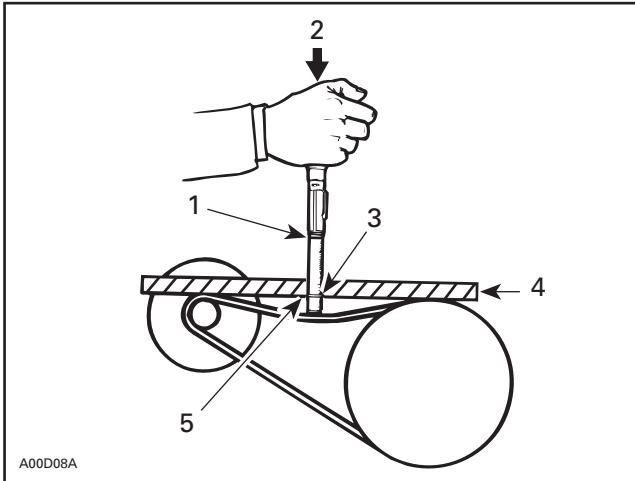

1. Upper O-ring — force
2. Force
3. Lower O-ring — deflection
4. Reference rule
5. Deflection

DEFLECTION ADJUSTMENT

Adjust pulley distance according to specification, refer to PULLEY DISTANCE AND ALIGNMENT.

Adjust drive belt deflection using Allen screws, as shown.

To increase deflection: turn Allen screws clockwise.

To decrease deflection: turn Allen screws counterclockwise.

NOTE: Turn Allen screws 1/4 turn at a time, then rotate driven pulley to allow drive belt to settle in pulley. Check deflection, repeat as required.

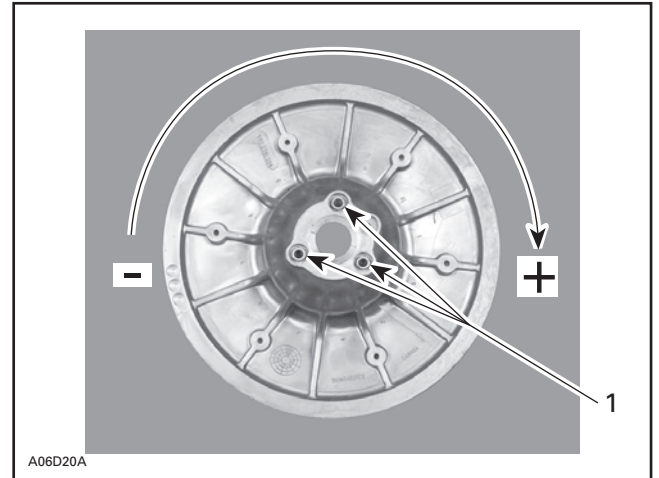

TYPICAL

1. Allen screw with jam nut

Allen screws must be restrained while tightening jam nut to prevent throwing adjustment out. Use drive belt tension adjuster (P/N 529 008 700).

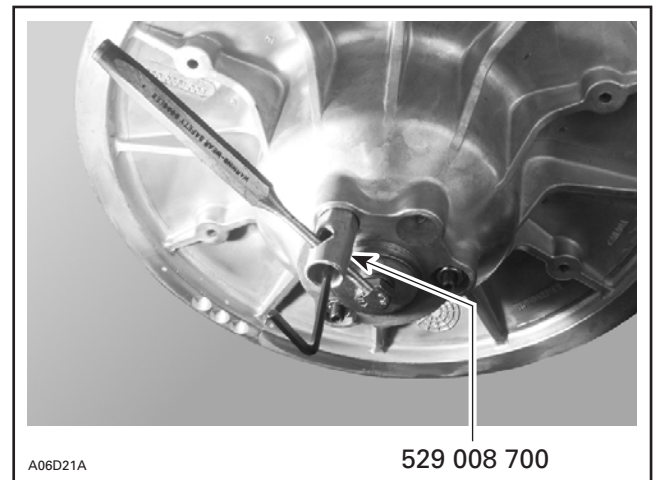

TYPICAL

Section 05 TRANSMISSION

Subsection 03 (DRIVE PULLEY)

GENERAL

Some drive pulley components (return spring, ramp) can be changed to improve vehicle performance in high altitude regions. A service bulletin will give information about calibration according to altitude.

CAUTION: Such modifications should only be performed by experienced mechanics since they can greatly affect vehicle performance. Verify spring specifications before installation. Do not only refer to the spring color code.

NOTE: TRA drive pulley stands for Total Range Adjustable drive pulley.

⚠ WARNING

Any drive pulley repairs must be performed by an authorized Bombardier snowmobile dealer, or other such qualified person. Subcomponent installation and assembly tolerances require strict adherence to procedures detailed.

REMOVAL

30,31, Conical Spring Washer and Screw

Use holder (P/N 529 006 400).

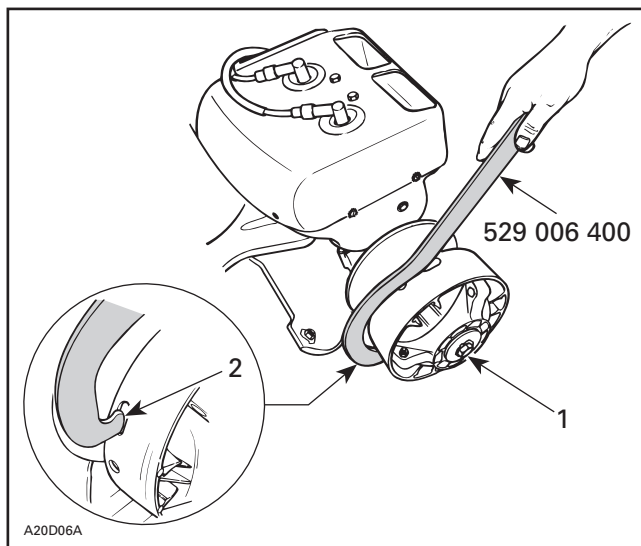

TYPICAL

1. Retaining screw
2. Insert in any slot

⚠ WARNING

Never use any type of impact wrench at drive pulley removal and installation.

Remove retaining screw.

To remove drive pulley ass'y and/or fixed half from engine, use puller (P/N 529 022 400).

CAUTION: These pulleys have metric threads. Do not use imperial threads puller. Always tighten puller by hand to ensure that the drive pulley has the same type of threads (metric vs imperial) prior to fully tightening.

To Remove Drive Pulley Ass'y:

Retain drive pulley with clutch holder.

Install puller in pulley shaft then tighten.

DISASSEMBLY

1,2, Screw and Ring Gear

CAUTION: Retaining screws must be heated before disassembly. Do not exceed 150°C (300°F).

5,6, Fixed and Sliding Half

CAUTION: Do not tap on governor cup.

Screw puller into fixed half shaft about 13 mm (1/2 in). Raise drive pulley and hold it by the sliding half while knocking on puller head to disengage fixed half.

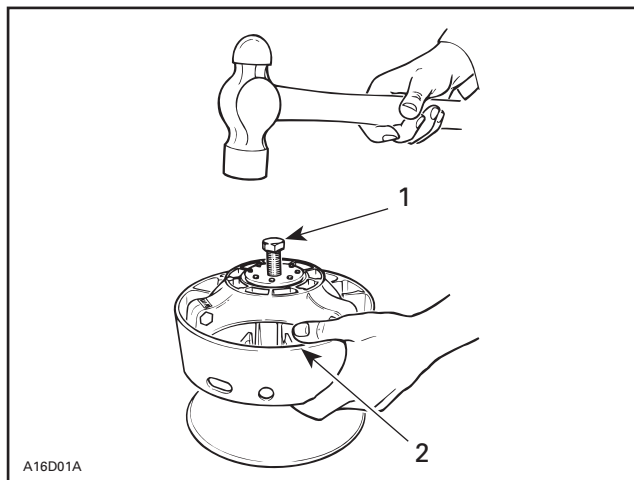

1. Puller
2. Holding sliding half

NOTE: No components marking is required before disassembling this drive pulley since it has factory mark and arrows as indexing reference.

32, Cushion Drive

CAUTION: Do not disassemble cushion drive. Governor cup and cushion drive are factory balanced as an assembly.

25,29, Slider Shoe and Governor Cup

Carefully lift governor cup until slider shoes come at their highest position into guides.

Hold a slider shoe set then carefully lift its housing and remove slider shoes. Proceed the same way for other housings lifting one at a time.

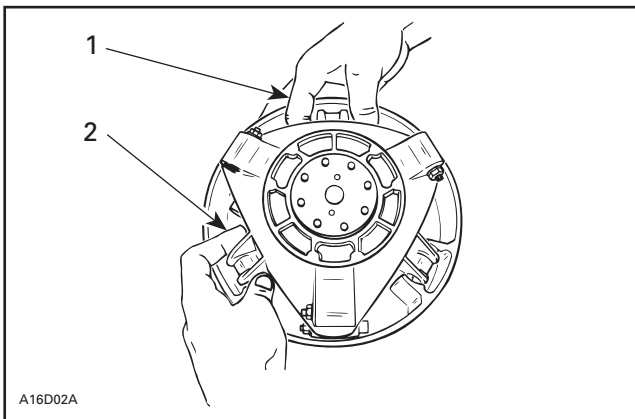

1. Hold slider shoes
2. Lift one housing at a time

NOTE: To ease disassembly, forks (P/N 529 005 500) should be used to hold slider shoes prior to removing governor cup.

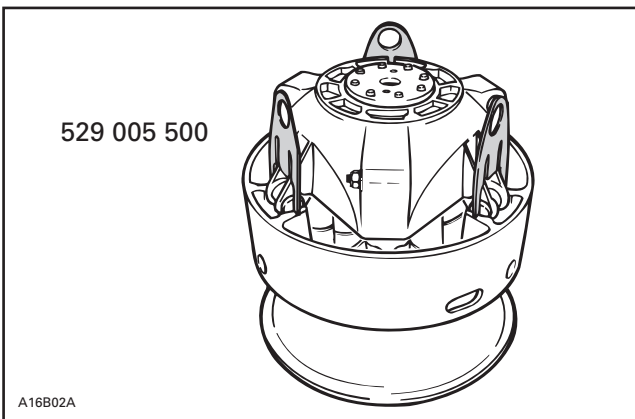

19, Spring Cover Ass'y

It is pushed by clutch spring pressure.

⚠ WARNING

Clutch spring is very strong. Never attempt to remove spring cover without the recommended tools.

Use spring compressor (P/N 529 035 524).
 Install support guide.

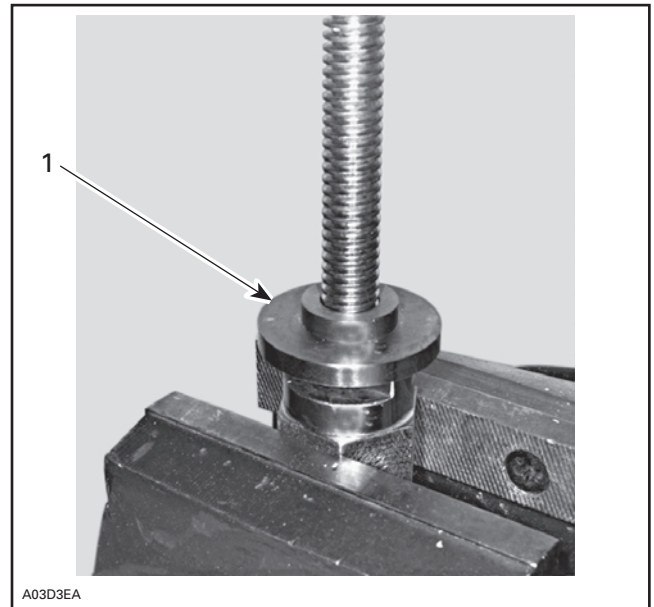

1. Support guide

Install sliding half then a second support guide. These support guides will prevent bushing damages.

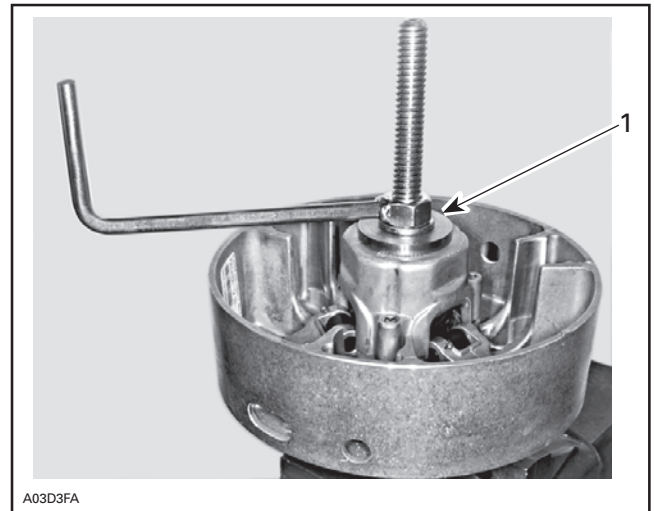

1. Support guide

Remove 3 Allen screws retaining spring cover then unscrew compressor.

CLEANING

5,6, Fixed and Sliding Half

Clean pulley faces and shaft with fine steel wool and dry cloth.

Section 05 TRANSMISSION

Subsection 03 (DRIVE PULLEY)

5, Fixed Half and Crankshaft End

Parts must be at room temperature before cleaning.

Using a paper towel with cleaning solvent, clean crankshaft tapered end and the taper inside the fixed half of the drive pulley, crankshaft threads and retaining screw threads.

WARNING

This procedure must be performed in a well-ventilated area.

CAUTION: Avoid contact between cleaner and crankshaft seal because damage may occur.

Remove all hardened oil deposits that have baked on crankshaft and pulley tapered surfaces with coarse or medium steel wool and/or sand paper no. 600.

CAUTION: Do not use any other type of abrasive.

Reclean mounting surfaces with paper towel and cleaning solvent.

Wipe off the mounting surfaces with a clean, dry paper towel.

CAUTION: Mounting surfaces must be free of any oil, cleaner or towel residue.

7,20, Bushing

Only use petrol base cleaner when cleaning bushings.

CAUTION: Do not use acetone to clean bushing.

INSPECTION

Drive pulley should be inspected annually.

16,17, Thrust Washer and Roller

Check roller for roundness of external diameter. Check thrust washer for thickness wear. Replace as required.

CAUTION: Ensure rollers are in good condition. Replace as required.

9,12, Fitting Bolt Ass'y and Flanged Bushing

Check for wear, replace as required.

24,25, O-Ring and Slider Shoe

Check if O-rings are cracked, cut or crushed. Replace as required.

Check slider shoes for wear. Replace if groove is not apparent on top.

5,29, Fixed Half and Governor Cup

Inspect splines and free play between both parts. Maximum free play is 0.5 mm (.020 in) measured at calibration screw radius. Replace if required.

7,20, Sliding Half and Spring Cover Bushing

Visually inspect coating. Replace if worn.

Sliding Half Bushing Replacement

This bushing is not replacable. If worn out, replace sliding half ass'y.

Spring Cover Bushing Replacement

Under normal use there is no need to replace this bushing.

This bushing is not replacable. If worn out, replace spring cover ass'y.

ASSEMBLY

NOTE: This drive pulley is lubrication free. Do not lubricate any component.

1,2,3, Screw, Ring Gear and Loctite 271

Apply Loctite 271 (P/N 413 702 900) on threads and then torque to 27 N•m (20 lbf•ft).

26,27,28, Calibration Screw, Washer and Locking Nut

When installing calibration screw, make sure to install washer as shown.

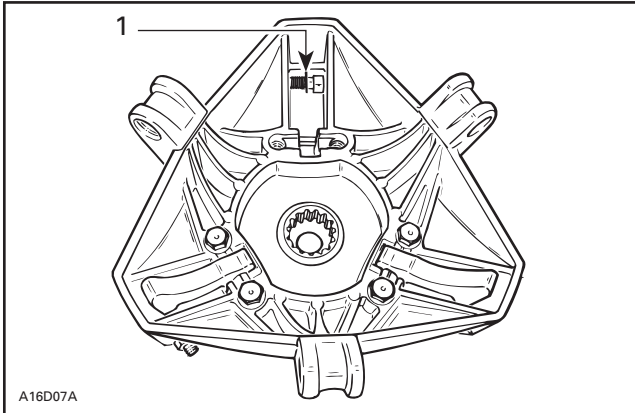

1. Washer

Torque locking nut to 10 N•m (89 lbf•in).

15, Pin

Always use the same type of pin as originally installed when servicing. Different types have different weights for calibration purpose. Refer to TECHNICAL DATA.

21,22,23, Ramp, Dowel Tube and Screw

Insert dowel tube from chamfered side. Make sure ramp is centered on dowel tube.

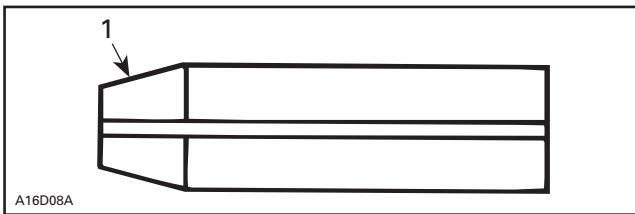

1. Chamfered side

Position dowel tube split at the illustrated angle.

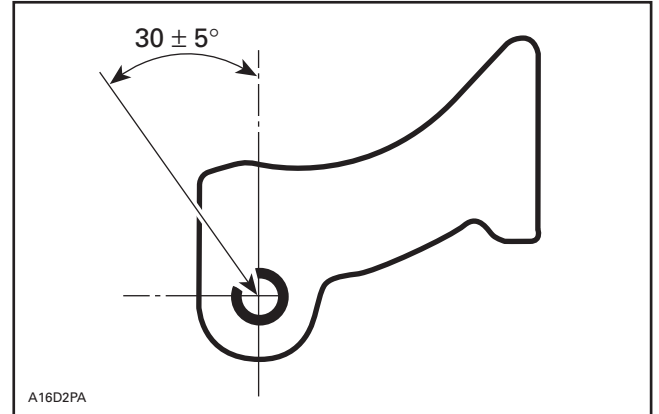

A16D2PA

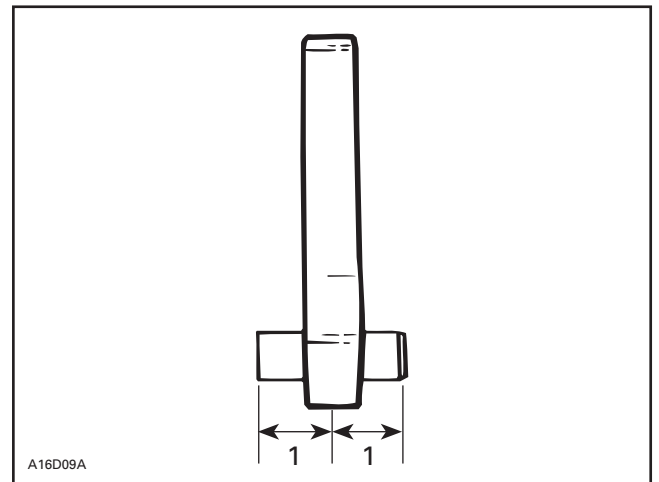

A16D09A

1. Equal distance

Torque screws to 10 N•m (89 lbf•in).

9,11,13,14, Screw, Lever Ass'y, Nut and Cotter Pin

Always install lever assemblies so that cotter pins are on the shown side. Besides install cotter pin head on top when lever is sat at bottom of sliding half. Bend cotter pin ends to sit perfectly against lever.

⚠ WARNING

Whenever replacing centrifugal levers, always replace all 3 at the same time. Otherwise, drive pulley misbalancing will occur because of levers difference.

Section 05 TRANSMISSION

Subsection 03 (DRIVE PULLEY)

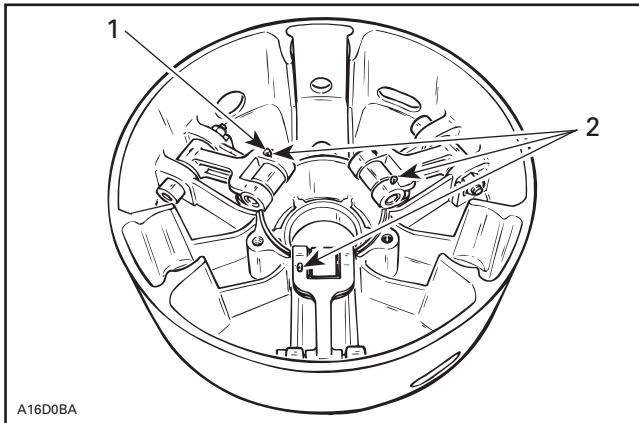

1. Head on top
2. All on the same side

CAUTION: Lever assemblies must be installed so that cotter pins are on the same side.

Torque nuts to 12 N•m (106 lbf•in).

CAUTION: Lever ass'y and rollers must move easily after installation.

33, Guard

Some Models Only

Install guard with its reinforcements in line with levers.

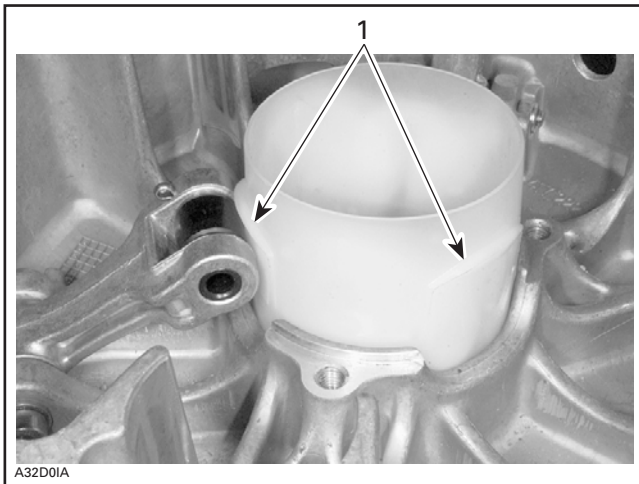

1. Reinforcements

5,6,18,19, Fixed Half, Sliding Half, Spring, Spring Cover and Screw

All Models

To install spring cover, use spring compressor (P/N 529 035 524). Align indexing arrows.

Assemble fixed and sliding halves.

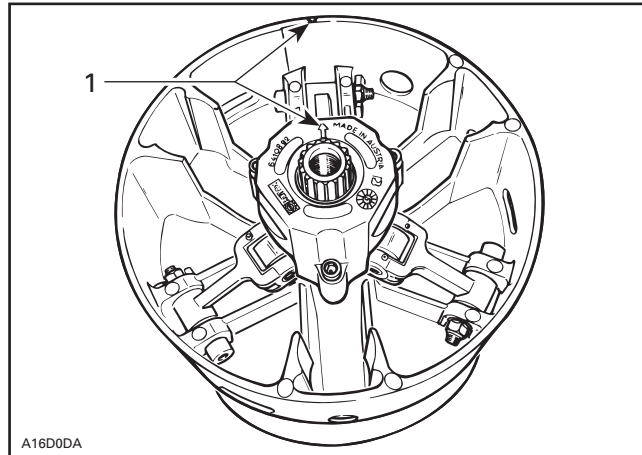

1. Align

Install and torque screws to 13 N•m (115 lbf•in) for 593 engine equipped models and to 16 N•m (142 lbf•in) for 693 and 793 engine equipped models.

6,25,29, Sliding Half, Slider Shoe and Governor Cup

To install governor cup, use following tool:

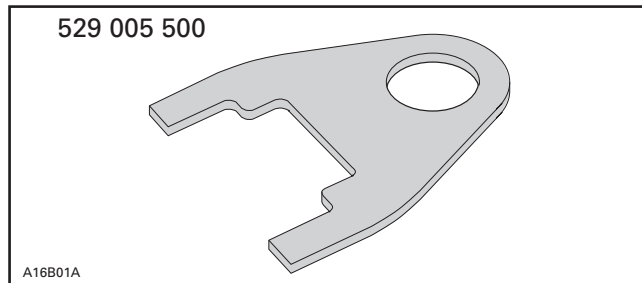

Insert spring and slider shoes into governor cup so that groove in each slider shoe is vertical to properly slide in guides.

CAUTION: Make sure O-rings are installed on slider shoes and their grooves are positioned vertically.

Install fork (P/N 529 005 500) into slider shoe grooves to maintain them for governor cup installation. Proceed on 3 set of slider shoes.

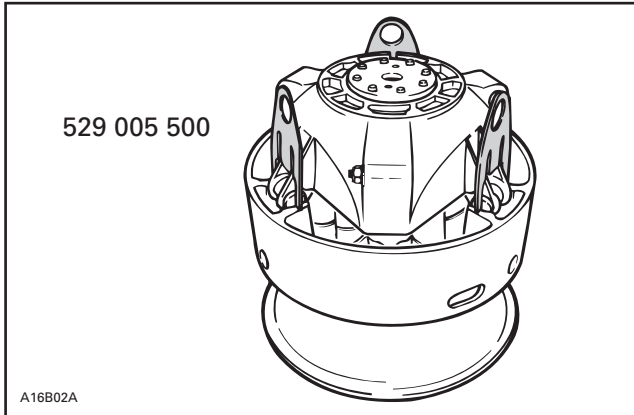

Make sure to align governor cup arrow with sliding half and fixed half mark.

NOTE: If fixed half has no mark, align governor cup mark with segment no. 1 of inner half. Segments are identified on engine side.

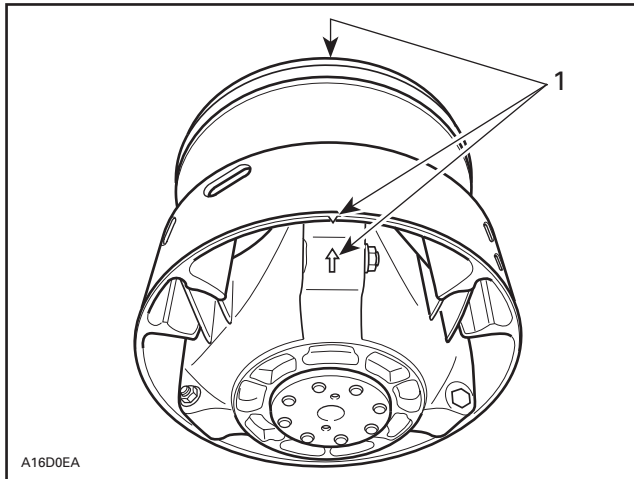

1. Align

Carefully slide governor cup into sliding half. Align mark of governor cup with mark of fixed half.

Remove forks and push governor cup so that its splines engage with fixed half shaft splines.

CAUTION: Make sure splines of both parts are fully engaged.

INSTALLATION

⚠ WARNING

Do not apply anti-seize or any lubricant on crankshaft and drive pulley tapers.

⚠ WARNING

Never use any type of impact wrench at drive pulley removal and installation.

Clean mounting surfaces as described in **CLEANING** above.

Drive Pulley Ass'y

The installation procedure must be strictly adhered to as follows.

Install drive pulley on crankshaft extension.

Install conical washer with its concave side towards drive pulley then install screw.

⚠ WARNING

Never substitute conical washer and/or screw with jobber ones. Always use Bombardier genuine parts for this particular case.

Use holder. See removal procedure.

Torque screw to 80 to 100 N•m (59 to 74 lbf•ft).

Install drive belt and guard.

Raise and block the rear of the vehicle and support it with a mechanical stand.

⚠ WARNING

Ensure that the track is free of particles which could be thrown out while track is rotating. Keep hands, tools, feet and clothing clear of track. Ensure nobody is standing near the vehicle.

Accelerate the vehicle at low speed (maximum 30 km/h (20 MPH) and apply the brake, repeat 5 times.

Recheck the torque of 90 to 100 N•m (66 to 74 lbf•ft).

Section 05 TRANSMISSION

Subsection 03 (DRIVE PULLEY)

WARNING

After 10 hours of operation the transmission system of the vehicle must be inspected to ensure the retaining screw is properly torqued.

DRIVE PULLEY ADJUSTMENT

The drive pulley is factory calibrated to transmit maximum engine power at a predefined RPM. Factors such as ambient temperature, altitude or surface condition may vary this critical engine RPM thus affecting snowmobile efficiency.

This adjustable drive pulley allows setting maximum engine RPM in the vehicle to maintain maximum power.

Calibration screws should be adjusted so that actual maximum engine RPM in vehicle matches with the maximum horsepower RPM given in TECHNICAL DATA.

NOTE: Use precision digital tachometer for engine RPM adjustment.

NOTE: The adjustment has an effect on high RPM only.

To adjust, modify ramp end position by turning calibration screws.

26,28,29, Calibration Screw, Locking Nut and Governor Cup

Calibration screw has a notch on top of its head.

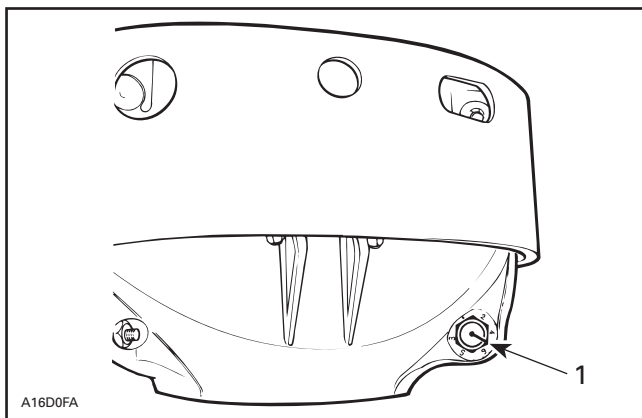

1. Notch

Governor cup has 6 positions numbered 2 to 6. Note that in position 1 there is no stamped number (due to its location on casting).

See TECHNICAL DATA for original setting.

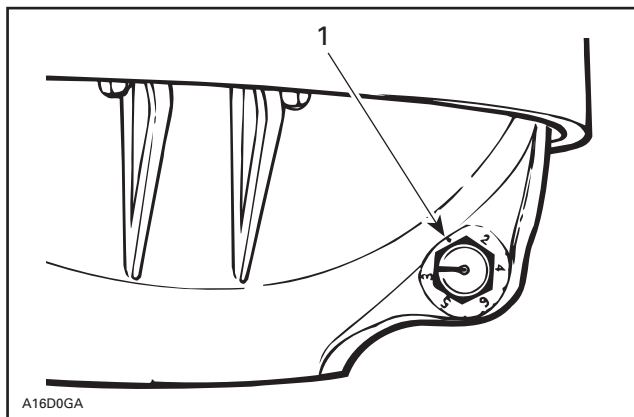

1. Position 1 (not numbered)

Each number modifies maximum engine RPM by about 200 RPM.

Lower numbers decrease engine RPM in steps of 200 RPM and higher numbers increase it in steps of 200 RPM.

Example:

Calibration screw is set at position 3 and is changed to position 5. So maximum engine RPM is increased by about 400 RPM.

To Adjust:

Just loosen locking nut enough to pull calibration screw **partially** out and adjust to desired position. Do not completely remove the locking nut. Torque locking nuts to 10 N•m (89 lbf•in).

CAUTION: Do not completely remove calibration screw otherwise its inside washer will fall off.

CAUTION: Always adjust all 3 calibration screws and make sure they are all set at the same number.

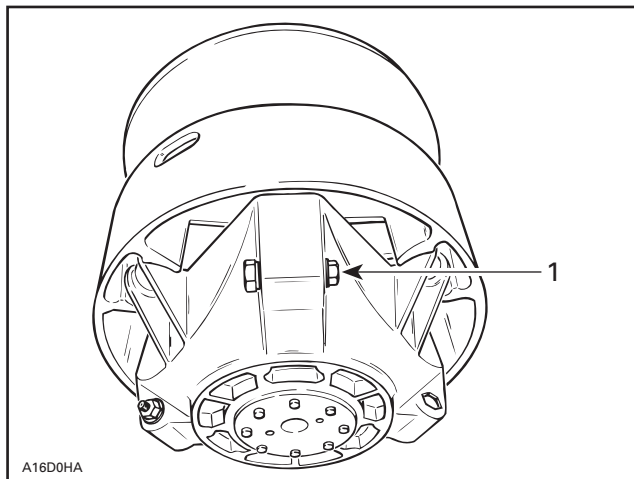

1. Loosen just enough to permit rotating of calibration screw

Section 05 TRANSMISSION

Subsection 04 (DRIVEN PULLEY)

REMOVAL

Remove guard and drive belt from vehicle.

Remove cap screw **no. 12** and shouldered washer **no. 11** then pull the driven pulley from the countershaft.

Note shouldered washer position for reinstallation.

Take care not to loose spacer **no. 2**.

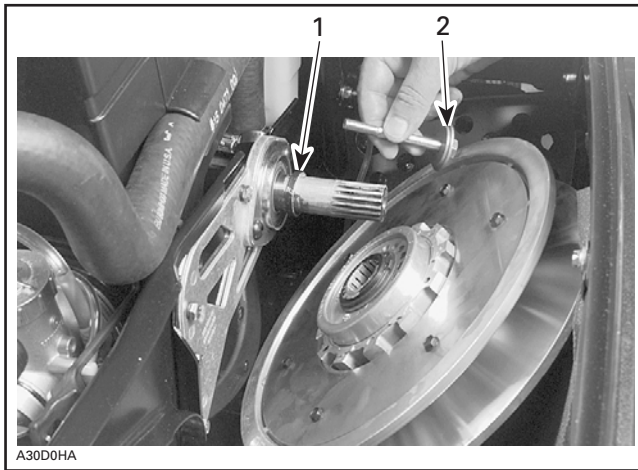

TYPICAL

1. Spacer
2. Shoulder on this side

1, Countershaft

Should countershaft **no. 1** removal be required, refer to BRAKE then look for **Countershaft and Brake Disc Removal**.

DISASSEMBLY

Use spring compressor (P/N 529 018 600).



Remove snap ring **no. 3** and washer **no. 4** to disassemble the cam and the two pulley halves.

WARNING

Driven pulley cam is spring loaded, use above-mentioned tool.

CLEANING

9,10, Large Bushing and Small Bushing

During break-in period (about 10 hours of use), teflon from bushing moves to cam or shaft surface. A teflon over teflon running condition occurs, leading to low friction. So it is normal to see gray teflon deposit on cam or shaft. Do not remove that deposit, it is not dust.

When a dust deposit has to be removed from the cam or the shaft, use dry cloth to avoid removing transferred teflon.

Pulley Half Cleaning

Use Parts Cleaner (P/N 413 711 809).

INSPECTION

9,10, Bushings

Check for cracks, scratch and for free movement when assembled to fixed half.

Using a dial bore gauge measure bushing diameter. Measuring point must be at least 5 mm (1/4 in) from bushing edge.



Replace bushing(s) if worn more than specified.

DRIVEN PULLEY BUSHING WEAR LIMIT mm (in)	
Small bushing	38.30 (1.508)
Large bushing	89.15 (3.510)

6, Slider Shoe

Check cam slider shoes for wear. Replace when inside edge of cam slider shoe slope base is worn to 1 mm (.039 in) or less.

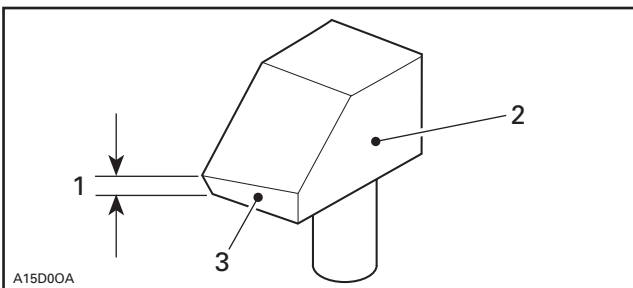

1. Measure thickness of slope base here
2. Sliding pulley side
3. Slope base

ASSEMBLY

6, Cam Slider Shoe

When replacing slider shoes, always install a new set (three shoes) to maintain equal pressure on the cam.

Assemble driven pulley components by reversing the disassembly procedure.

5, Cam

Coat cam interior with anti-seize lubricant.

INSTALLATION

1, Countershaft

CAUTION: Always apply anti-seize lubricant (P/N 293 800 070) on the countershaft before final pulley installation.

Should installation procedure be required, refer to BRAKE then look for **Brake Disc and Countershaft Bearing Adjustment**.

Reinstall the pulley on the countershaft by reversing the removal procedure.

Driven pulley end-play is 0 (zero).

12, Pulley Retaining Screw

Torque to 22 N•m (16 lbf•ft).

ADJUSTMENT

Refer to PULLEY DISTANCE AND ALIGNMENT to adjust pulley distance. Adjust drive belt height in driven pulley to obtain specified belt deflection. Turn Allen screws **no. 10** equally accordingly.

7, Spring

General

It is usual to experience spring setting during break-in period of a new spring. The factory spring preload is slightly higher (about 1 kg (2 lb)) to compensate for spring setting. Specifications in TECHNICAL DATA are applicable after break-in period (about 10 hours of use).

Spring Torsional Pre-Load

To check spring pre-load adjustment, use spring scale hook (P/N 529 006 500) and a spring scale.

Remove drive belt.

Section 05 TRANSMISSION

Subsection 04 (DRIVEN PULLEY)

Install the hook on the sliding half. Preventing fixed half from turning, pull sliding half with the spring scale perpendicularly with pulley axle.

Take 1st measurement when sliding half begins to turn. Rotate sliding half to 10 mm (3/8 in) of rotation. Hold fish scale at this position. Slowly release tension from fish scale and take 2nd measurement when sliding half begins to return. Spring pre-load is the average measurement between these two.

$$\frac{\begin{array}{l} 1^{\text{st}} \\ \text{measurement} \\ \text{(when} \\ \text{opening)} \end{array} + \begin{array}{l} 2^{\text{nd}} \\ \text{measurement} \\ \text{(when closing)} \end{array}}{2} = \text{Spring pre-load}$$

Example:

$$\frac{\begin{array}{l} 3.8 \text{ kg} \\ (8.4 \text{ lb}) \\ \text{(when} \\ \text{opening)} \end{array} + \begin{array}{l} 3.4 \text{ kg} \\ (7.5 \text{ lb}) \\ \text{(when} \\ \text{closing)} \end{array}}{2} = \begin{array}{l} 3.6 \text{ kg} \\ (8 \text{ lb}) \\ \text{Actual} \\ \text{spring} \\ \text{pre-load} \end{array}$$

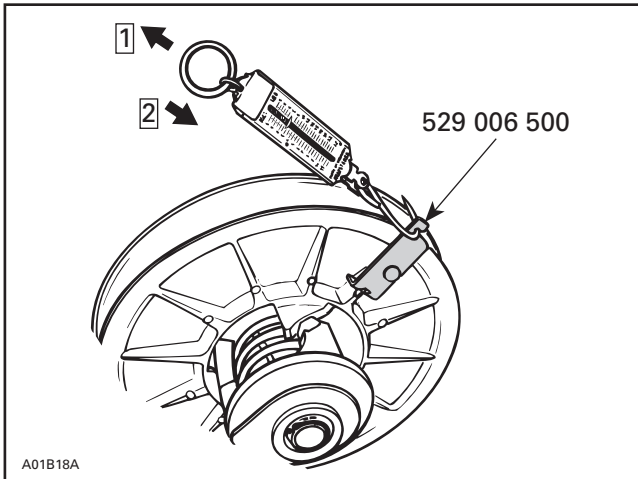

TYPICAL

Step 1: 1st measurement
Step 2: 2nd measurement

To adjust spring pre-load, relocate spring end in cam, moving it clockwise to increase the pre-load and counterclockwise to decrease it. Refer to TECHNICAL DATA.

NOTE: If spring pre-load can not be adjusted, try to relocate the other end of spring in sliding pulley (holes A, B and C).

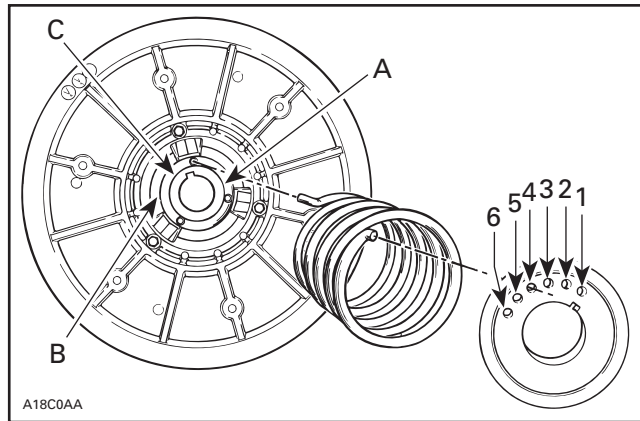

TYPICAL

Letters and numbers shown in illustration are actual letters and numbers embossed on parts

NOTE: Always recheck torsional pre-load after adjusting.

Pulley Alignment and Drive Belt Deflection

Refer to PULLEY DISTANCE AND ALIGNMENT and DRIVE BELT to perform adjustments.

CAUTION: Drive belt and pulley adjustments must always be checked whenever pulleys have been removed, replaced or disassembled.

5, Cam

Make sure to install proper cam. Refer to TECHNICAL DATA.

Cam angle is identified on cam.

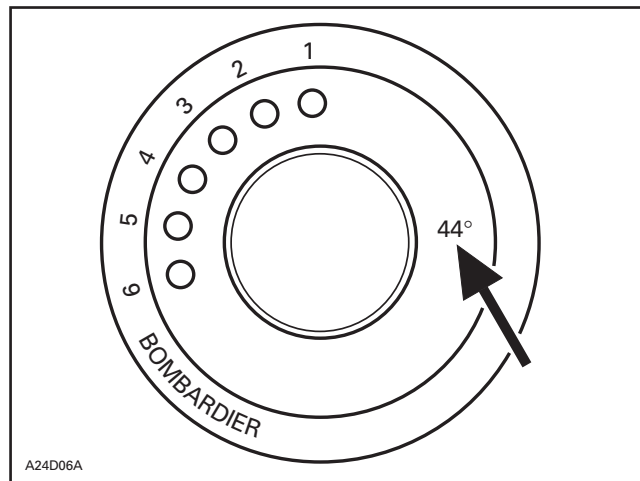

NOTE: For high altitude regions, a service bulletin will give information about calibration according to altitude.

PULLEY DISTANCE AND ALIGNMENT

GENERAL

The pulley distance we will refer to in this section, is the space separating the drive and driven pulley outside diameters (Z measurement).

This basic distance is provided as an assembly guide and indicates the dimensions between which satisfactory belt deflection will be obtained.

Both pulley distance adjustment and pulley alignment must be carried out to ensure the highest efficiency of the transmission system. Furthermore, optimum drive belt operation and minimal wear will be obtained only with proper pulley alignment.

CAUTION: Before checking pulley adjustment, the rear suspension must be mounted on the vehicle and track tension/alignment must be done. Always check pulley adjustment after suspension is adjusted.

WARNING

Failure to correctly perform pulley alignment may cause the vehicle to creep forward at idle.

All Pulley Alignment Specifications Refer to:

X = Distance between straight bar and drive pulley fixed half edge, **measured between pulleys.**

Y = Distance between straight bar and drive pulley fixed half edge, **measured at the end of straight bar.**

Z = Distance between outside diameter of pulleys.

GENERAL PROCEDURE

Remove guard and drive belt.

By turning and pushing the sliding half, open the driven pulley. Insert a straight bar 9.5 mm (.375 in) square, 48 cm (19 in) long or the proper alignment template into the opened driven pulley.

Measuring Procedure

Using Straight Bar

Always measure distances X and Y from the farther straight bar side (including its thickness to the fixed half edge).

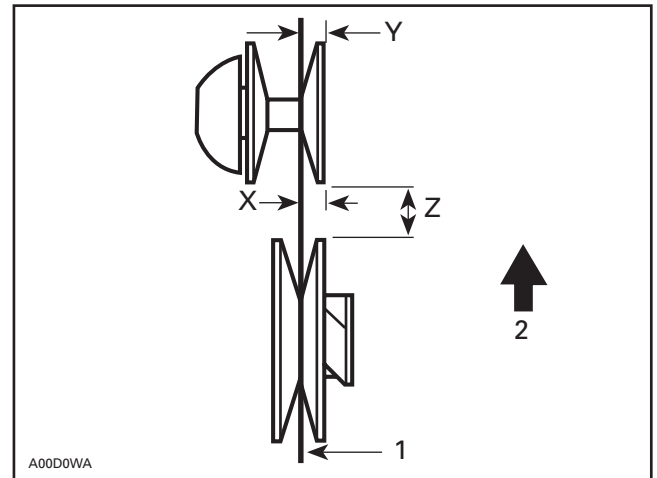

TYPICAL

1. Straight bar
2. Front of vehicle

The distance Y **must** exceed distance X to compensate for the twist due to the engine torque.

Drive Belt Deflection

NOTE: When pulley distance and alignment are adjusted to specifications, refer to DRIVE BELT to adjust drive belt deflection.

CAUTION: This section deals mainly with adjustment procedures. For complete assembly requirements, refer to the proper ENGINE or TRANSMISSION installation section.

Section 05 TRANSMISSION

Subsection 05 (PULLEY DISTANCE AND ALIGNMENT)

PULLEY ALIGNMENT AND DISTANCE SPECIFICATIONS CHART

MODEL	PULLEY DISTANCE	OFFSET		ALIGNMENT TEMPLATE ① P/N
	Z	X	Y-X	
	± 0.50 mm (.020 in)	± 0.50 mm (.020 in)	± 0.5 mm (.020 in)	
All	16.5 (.650)	35.50 (1.398)	1.5 (.060)	529 026 700

① Alignment templates have been made according to pulley alignment nominal values. However, they do not take into account allowed tolerances for alignment specifications. They are used as GO/NO GO gauges for quick alignment and pulley distance check and as templates to reach alignment nominal values.

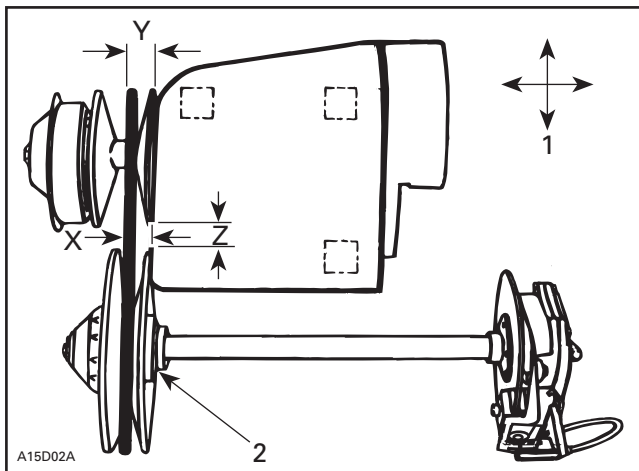

TYPICAL

1. Engine movement
2. Contact

NOTE: Prior to performing pulley adjustment, loosen torque rod nut to allow engine movement. Engine supports have tendency to stick to frame, work engine loose prior to aligning.

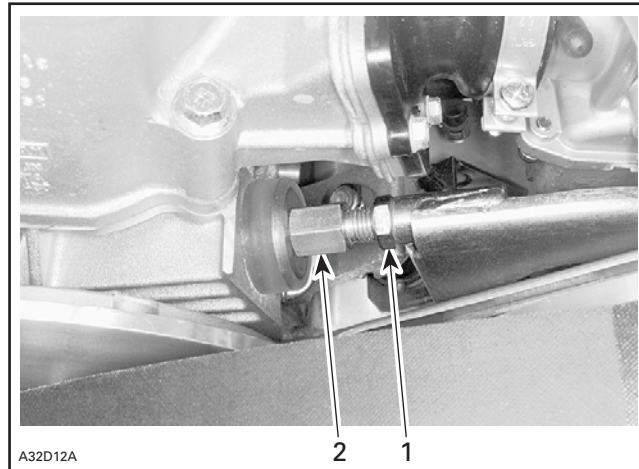

1. Loosen lock nut first
2. Loosen

Pulley Distance Adjustment Method

Engine Movement

The engine support has slotted mounting holes. Move engine to obtain specified distance between pulleys.

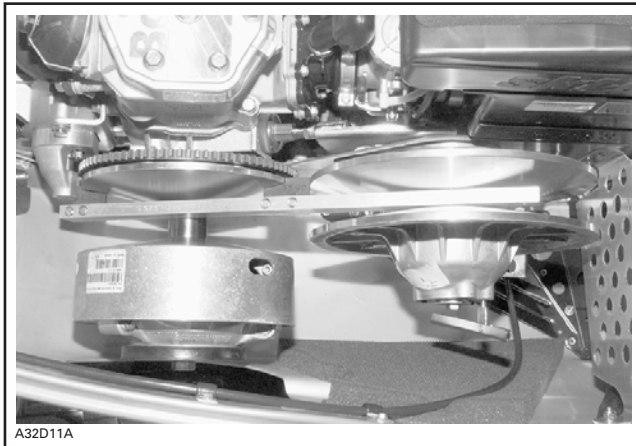

ALIGNMENT BAR IN PULLEYS

Pulley Alignment Method

Engine Movement

Loosen the 4 bolts retaining engine support to the frame. Position engine to obtain the specified alignment.

NOTE: After alignment, adjust torque rod so it slightly contacts stopper plate. Do not over tighten, it will disalign pulleys.

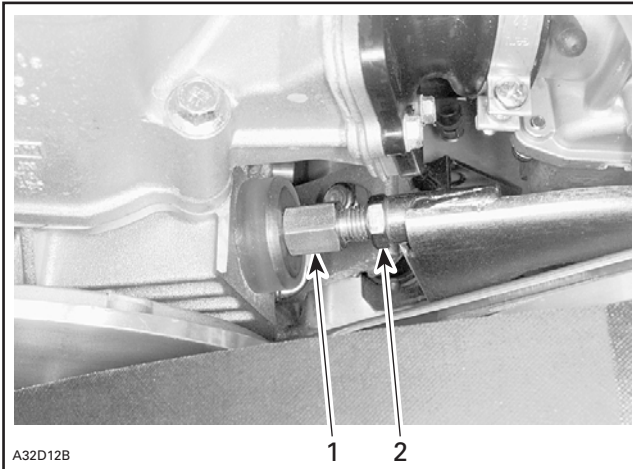

1. Slightly tighten
2. Retighten

BRAKE

HYDRAULIC DISC BRAKE

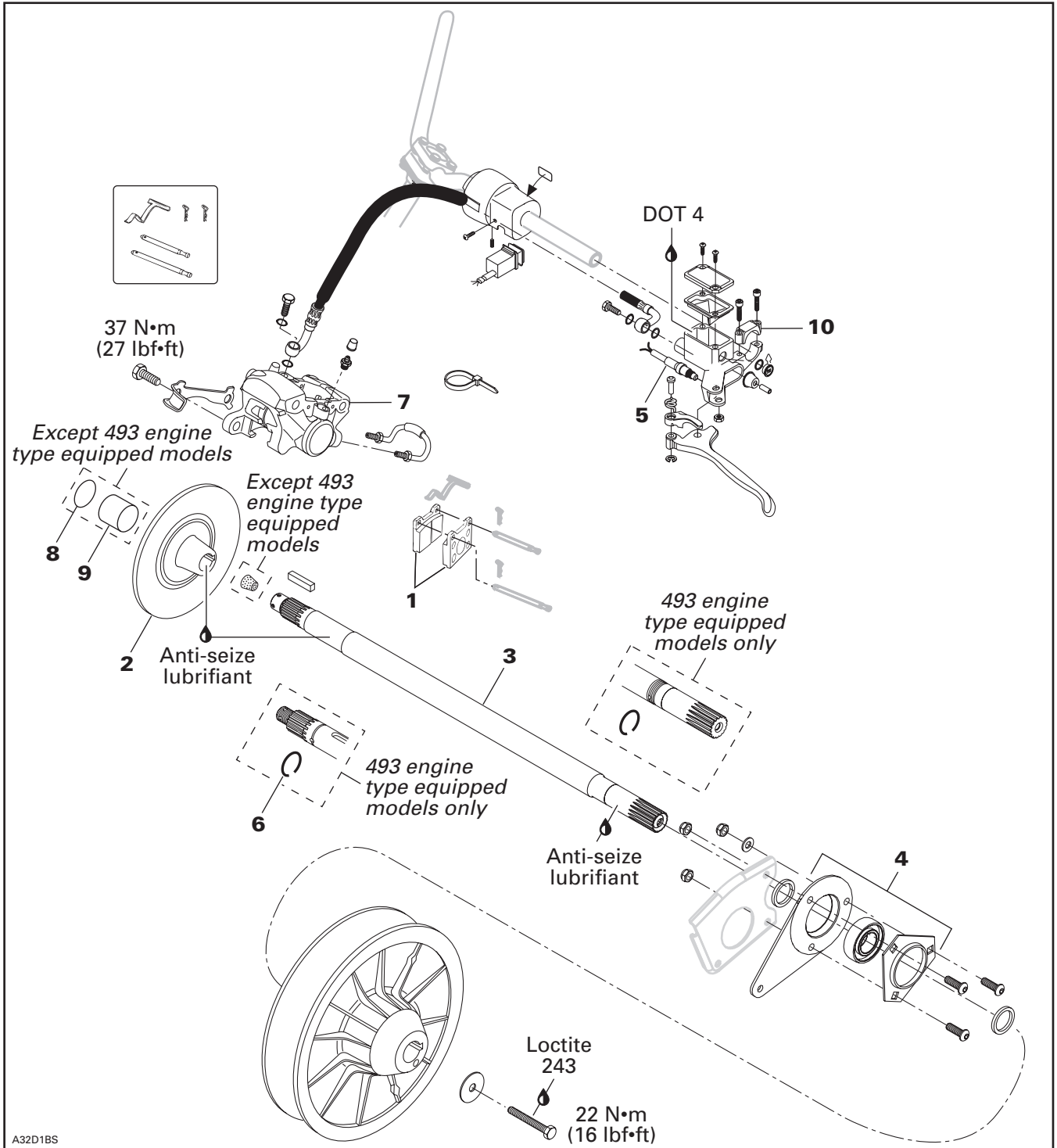

A32D1BS

Section 05 TRANSMISSION

Subsection 06 (BRAKE)

REMOVAL

All Models

BRAKE DISC REMOVAL

Brake disc can be withdrawn without removing chaincase. Proceed as follows:

- Remove belt guard, belt and driven pulley.
- Remove air silencer.
- Unbolt bearing support **no. 4** from chassis.
- Unbolt caliper from chaincase.
- Open chaincase and remove upper sprocket.

493 Engine Type Equipped Models

- Pull countershaft ass’y **no. 3** toward driven pulley side to get access to clip **no. 6** on countershaft.

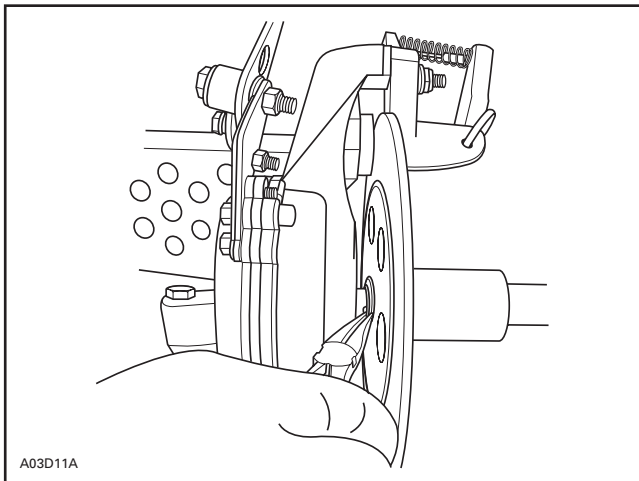

TYPICAL

All Models

- Pull countershaft **no. 3** toward driven pulley side to free from chaincase and disc.
- Remove disc.

DISASSEMBLY

Only brake pads are available as spare parts. If caliper or master cylinder are damaged, replace each of them as an assembly.

CLEANING

Clean all metal components in a general purpose solvent. Thoroughly dry all components before assembling.

CAUTION: Do not clean brake pads in solvent. Soiled brake pads must be replaced by new ones.

INSPECTION

1, Brake Pad

Brake pads must be replaced when lining is 1 mm (1/32 in) thick or less.

CAUTION: Brake pads must always be replaced in pairs.

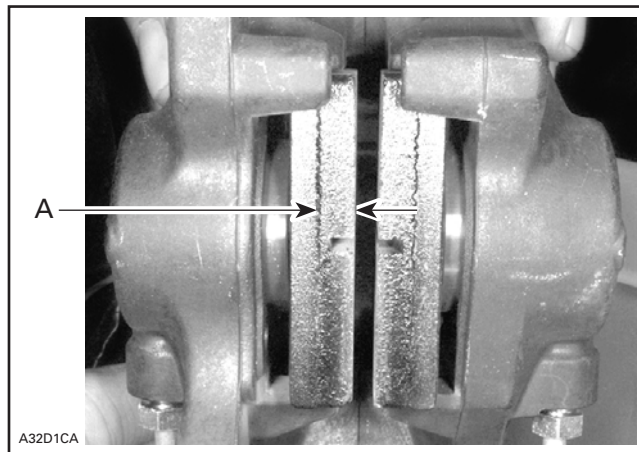

TYPICAL

A. 1 mm (1/32 in) minimum

2, Brake Disc

Check for scoring, cracking or bending, replace as required.

CAUTION: Brake disc should never be machined.

INSTALLATION

To install brake, reverse removal procedure paying attention to the following.

⚠ WARNING

Avoid getting oil on brake pads.

10, Upper Clamp

Install upper clamp with its arrow pointing at front of vehicle. Tighten to 8 N•m (71 lbf•in) front screw before rear one.

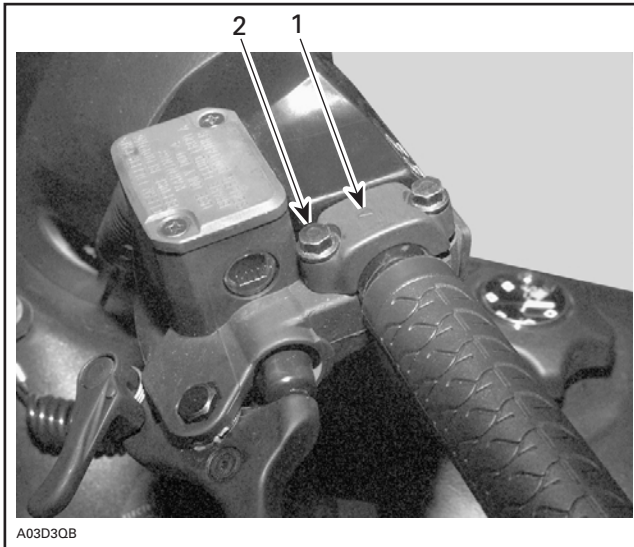

1. Arrow on upper clamp pointing at front of vehicle
2. Tighten front screw first

8,9, O-Ring and Spacer

All Models except 493 Engine Type Equipped Models

Make sure that O-ring and spacer are inserted into chaincase upper oil seal before reinstalling countershaft.

2, Brake Disc

Apply anti-seize lubricant (P/N 413 701 000) on shaft.

The disc hub exceeds the disc more from one side than from the other. Install disc with the longer exceeding portion toward driven pulley.

1,7, Brake Pads and Caliper

Each time a new caliper or new brake pads are installed, proceed with the following:

- With caliper not bolted to chaincase, apply brake few times until both new pads are touching each other.
- Push back pads and repeat above step.
- Push back pads then fasten caliper to chaincase.
- Proceed with bleeding as described below.

ADJUSTMENT

Countershaft Bearing

Insert countershaft (with brake disc) from chaincase side through countershaft support (driven pulley side), then insert into chaincase.

Torque castellated nut of upper sprocket to 60 N•m (44 lbf•ft).

CAUTION: Upper sprocket castellated nut must be tightened **before** bolting bearing support.

Close chaincase.

Install countershaft bearing no. 4 and ensure that countershaft is properly aligned, then tighten 3 retaining screws.

BLEEDING

Change brake fluid once a year.

Bleed brake system as follows:

Keep sufficient DOT 4 brake fluid in reservoir at all times.

CAUTION: Use only DOT 4 brake fluid.

Install a hose on left side bleeder. Route this hose to a container.

Pump a few times brake lever and while holding brake lever depressed, open left side bleeder and check for air to escape.

Repeat with the same bleeder until no air appears in hose.

Proceed the same way with the right side bleeder.

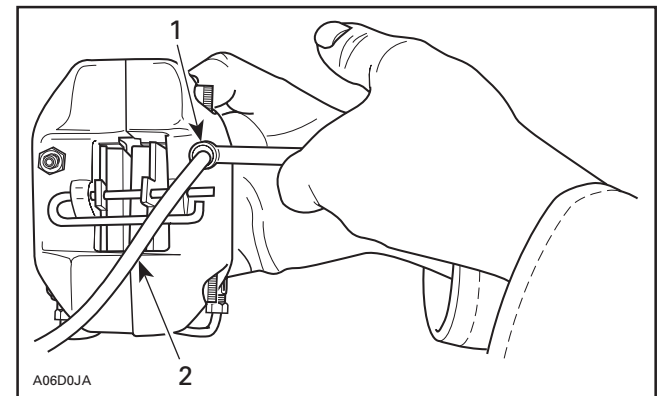

TYPICAL

1. Open bleeder
2. Clear hose to catch used brake fluid

5, Brake Light

There is no adjustment on these models. Check that switch is securely installed.

CHAINCASE

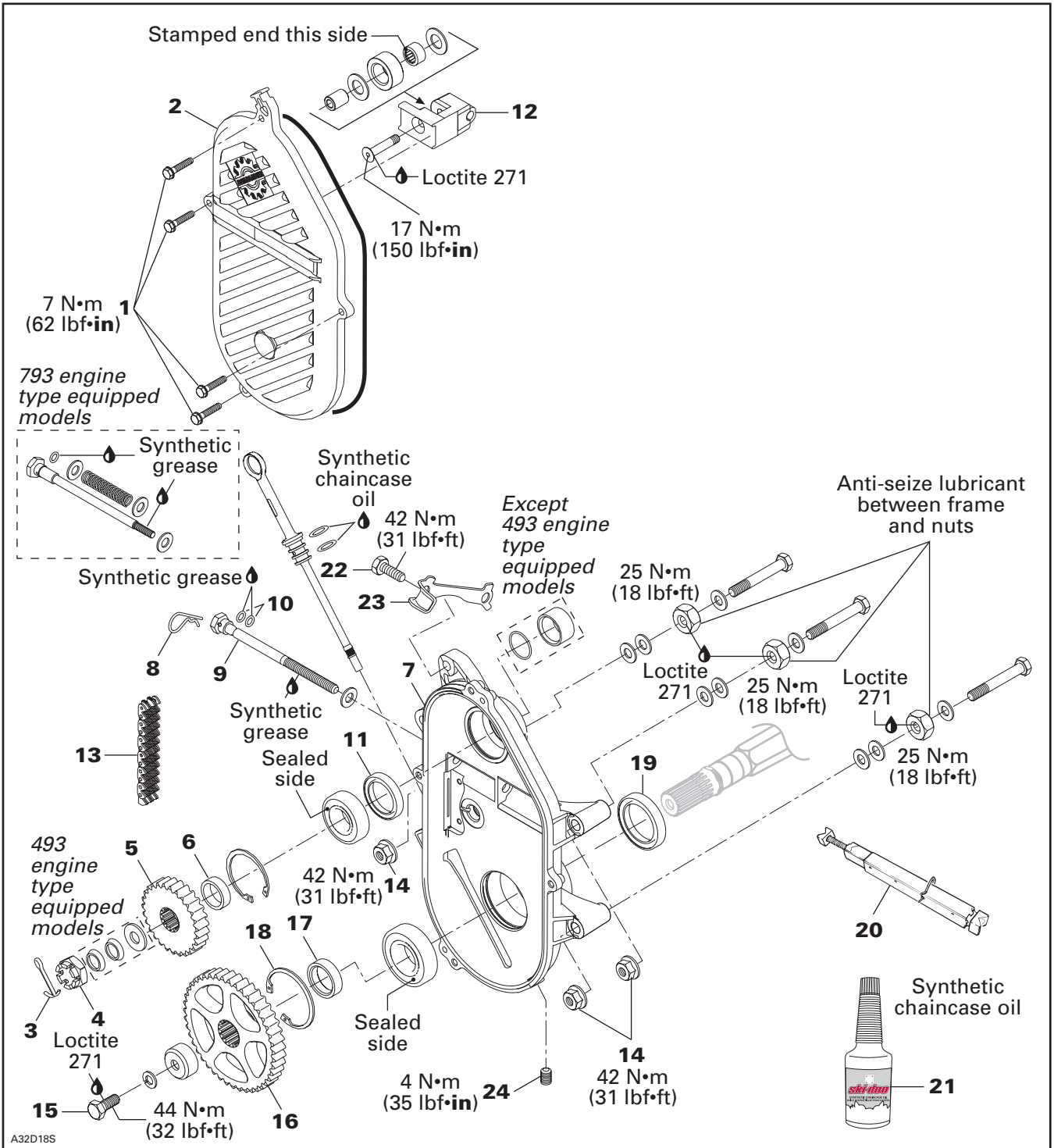

Section 05 TRANSMISSION

Subsection 07 (CHAINCASE)

REMOVAL AND DISASSEMBLY

To remove chaincase proceed as follows.

Remove tuned pipes and muffler.

WARNING

Never remove exhaust components when engine is hot.

Remove hair pin no. 8. Release drive chain tension by unscrewing tensioner adjustment screw.

Drain oil by removing drain plug no. 24.

3,4,5,6,13,16,17, Cotter Pin, Nut, Sprocket, Shim and Drive Chain

Apply parking brake.

Remove cotter pin no. 3 and nut no. 4 retaining upper sprocket no. 5 and screw no. 15 retaining lower sprocket no. 16. Pull sprockets and drive chain simultaneously. Remove shims nos. 6 and 17.

NOTE: Should countershaft removal be required, refer to BRAKE then look for **Countershaft Removal**.

Release parking brake.

Remove 3 nuts no. 14.

Unfold locking tab no. 23 then remove caliper retaining screws no. 22.

Release track tension, use drive axle holder no. 20 (P/N 529 007 200).

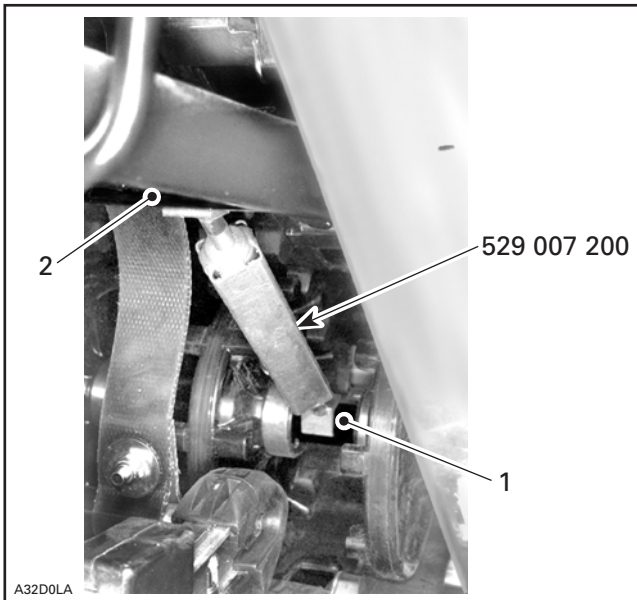

1. Drive axle
2. Suspension front arm upper axle

Pry out drive axle oil seal no. 19 from chaincase.

Pull chaincase from drive axle and countershaft.

Using 2 large prybars inserted between chaincase housing no. 7 and frame, pry complete assembly from vehicle.

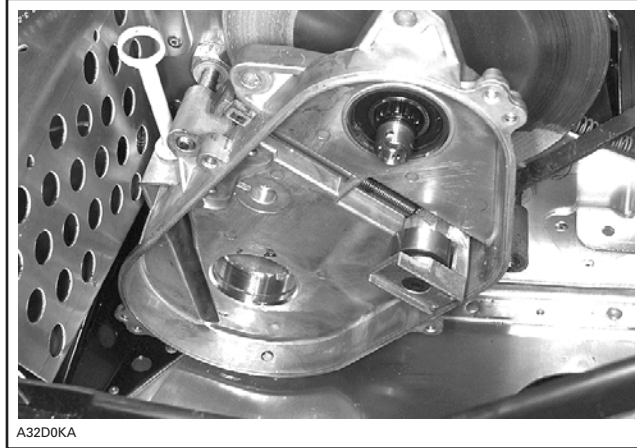

CHAINCASE HOUSING REMOVAL

INSPECTION

Visually inspect the chain for cracked, damaged or missing links. Check for worn or defective bearings, sprockets and chain tensioner components.

WARNING

If chain deflection is greater than 38 mm (1.5 in) (without chain tensioner), replace chain and check condition of sprockets.

GEAR RATIO MODIFICATION

For particular applications, the number of teeth of the sprockets can be increased or decreased on lower and upper sprockets.

Refer to TECHNICAL DATA for gear ratios.

CAUTION: Gear ratio modifications should only be performed by experienced mechanics since they can greatly affect vehicle performance.

NOTE: For high altitude regions, a Service Bulletin will give information about calibration according to altitude.

INSTALLATION AND ASSEMBLY

Reverse removal and disassembly procedure and pay attention to the following. Replace oil seals, gaskets O-rings and drain plug.

25, Hardened Washer

793 Engine Equipped Models Only

Make sure to install a hardened washer on each end of spring.

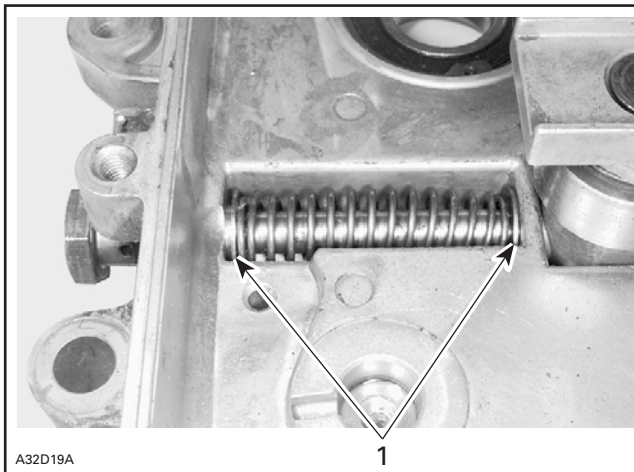

1. Hardened washers

All Models

11, Oil Seal

Using an appropriate pusher, press the oil seal into chaincase hub. Oil seal must fit flush with the chaincase edge.

NOTE: Should installation procedure for countershaft be required, refer to BRAKE.

5,16, Sprockets

Position the sprockets with the writing facing the chaincase cover. Sprocket hub faces toward chaincase.

4, Upper Sprocket Castellated Nut

Torque to 45 to 75 N•m (33 to 55 lbf•ft).

Install new cotter pin in the position shown.

CAUTION: When removing a cotter pin always replace with a new one.

CAUTION: Cotter pin will rub on chaincase cover if installed otherwise.

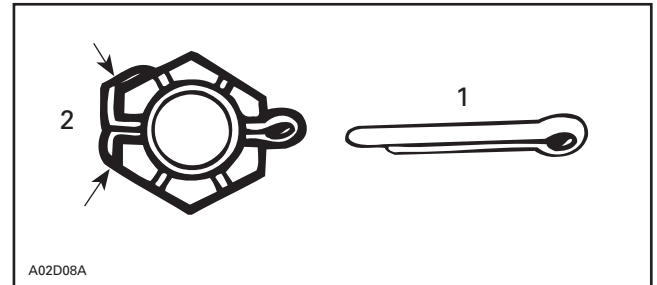

1. New
2. Fold cotter pin over castellated nut flats only

18, Circlip

CAUTION: It is of the utmost importance to install the circlip otherwise damage to the chaincase components may occur.

DRIVE CHAIN ADJUSTMENT

NOTE: Brake disc key must be in good condition before checking chain free play.

10, O-Ring

Replace O-ring no. 10 on tensioner adjustment screw. Fully tighten tensioner adjustment screw **by hand**, then back off only far enough for hair pin to engage in locking hole.

This initial adjustment should provide 3 - 5 mm (1/8 - 13/64 in) free-play when measured at the outer circumference of the brake disc.

CAUTION: Free-play must not exceed 5 mm (13/64 in), readjust if necessary.

WARNING

If the specified free-play is not reached with the tensioner screw fully tightened, replace chain and check the condition of sprockets.

Section 05 TRANSMISSION

Subsection 07 (CHAINCASE)

21, Chaincase Oil

Pour 250 mL (8.5 U.S. oz) of synthetic chaincase oil (P/N 413 803 300) into chaincase.

NOTE: Chaincase oil capacity is 250 mL (8.5 U.S. oz).

Check oil level with the dipstick then add if required. Remove metal particles from magnet.

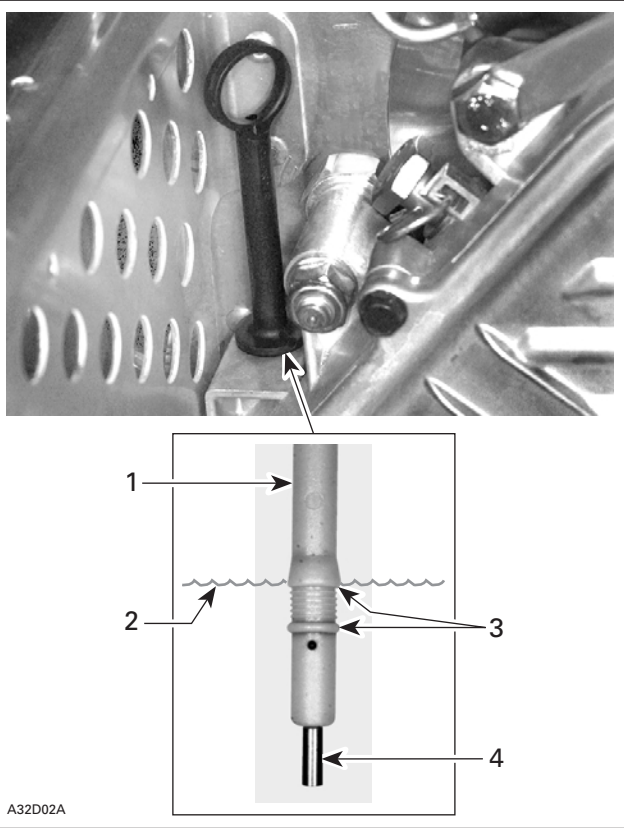

TYPICAL

1. Dipstick
2. Oil level
3. Level between marks
4. Magnet

NOTE: Chaincase must be in its proper position when checking oil level.

ADJUSTMENT

Pulley Alignment

Refer to PULLEY DISTANCE AND ALIGNMENT.

Track Tension and Alignment

Refer to TRACK.

GEARBOX

Grand Touring 500/600/700 and Formula Deluxe 500/600/700

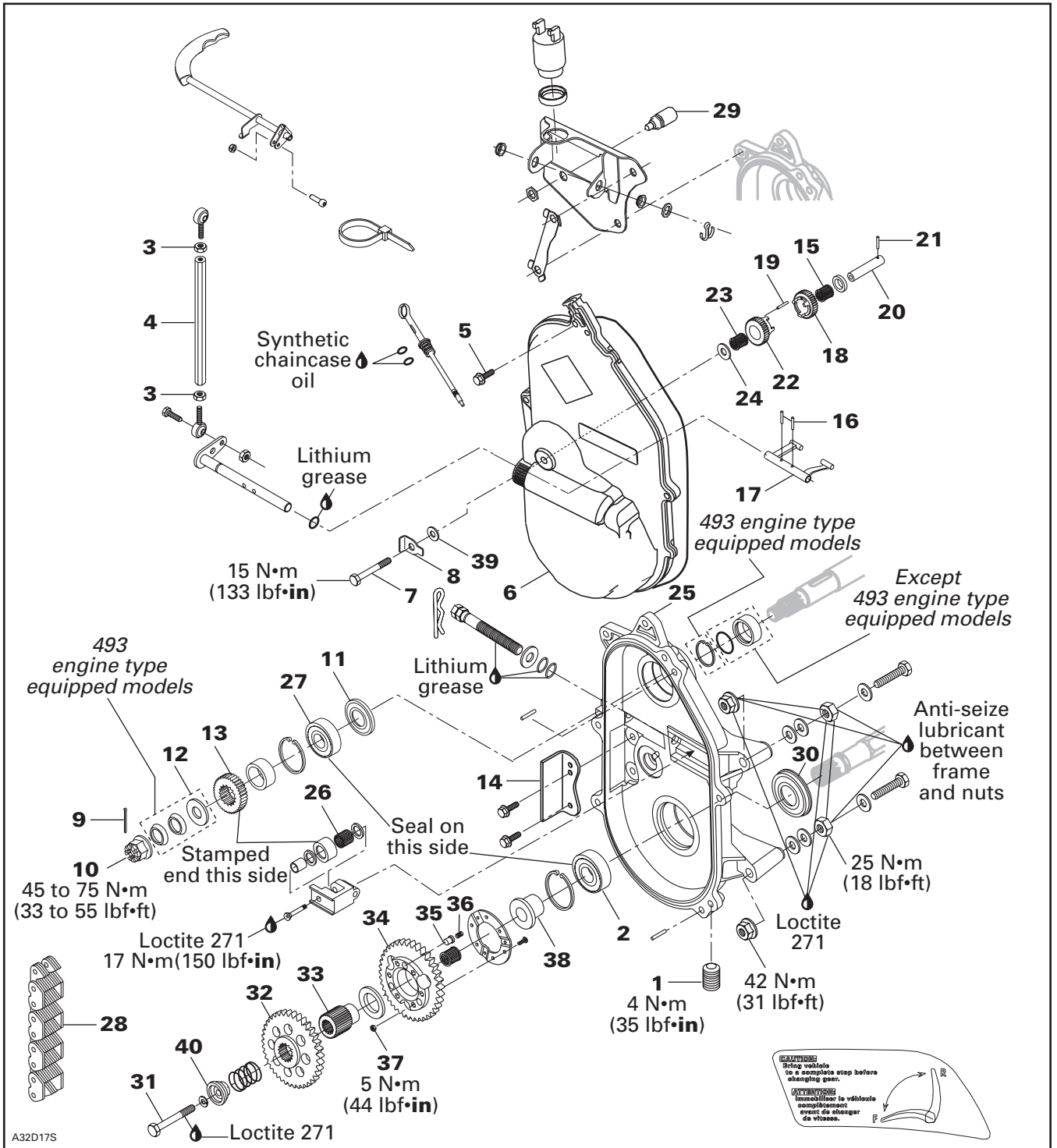

A32D17S

Section 05 TRANSMISSION

Subsection 08 (GEARBOX)

DISASSEMBLY

Disconnect negative cable from battery if so equipped.

Drain gearbox oil by removing drain plug **no. 1**.

Remove tuned pipe, muffler and muffler grommet.

Remove battery then, battery rack if so equipped.

Unscrew cover screws **no. 5** as well as reverse axle screw **no. 7**.

Separate cover **no. 6** from housing and move it toward the front in order to disengage fork from sliding gear.

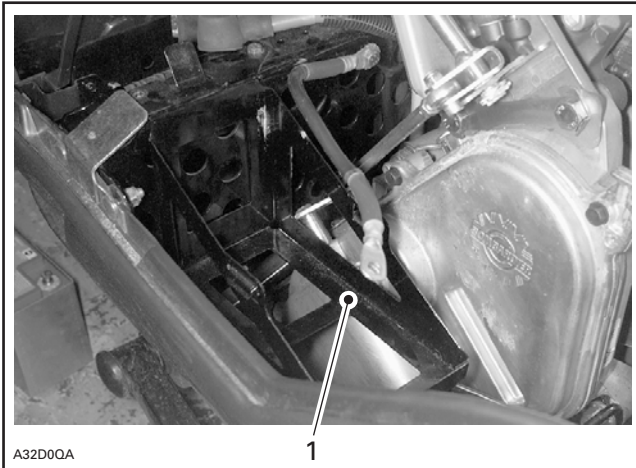

1. Battery rack

Unfasten tie rod from shifter.

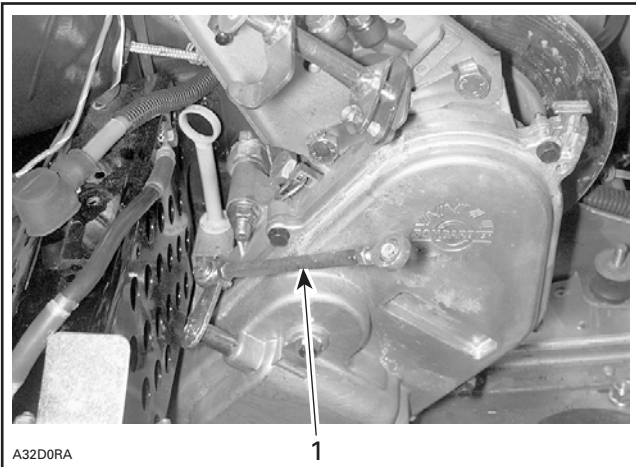

1. Tie rod

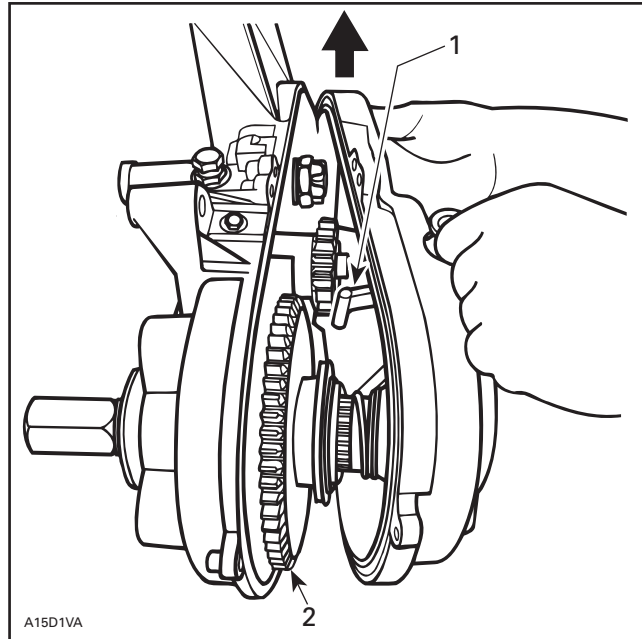

TYPICAL

1. Fork
2. Sliding gear

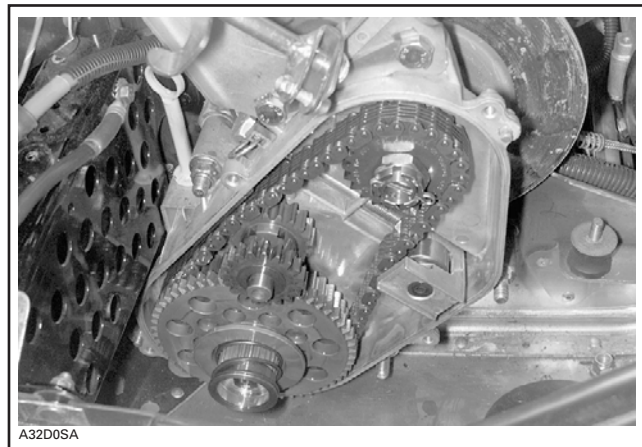

GEARBOX COVER REMOVED

Loosen chain tension, unscrew sliding gear retaining screw no. 31, then remove sliding gear no. 32.

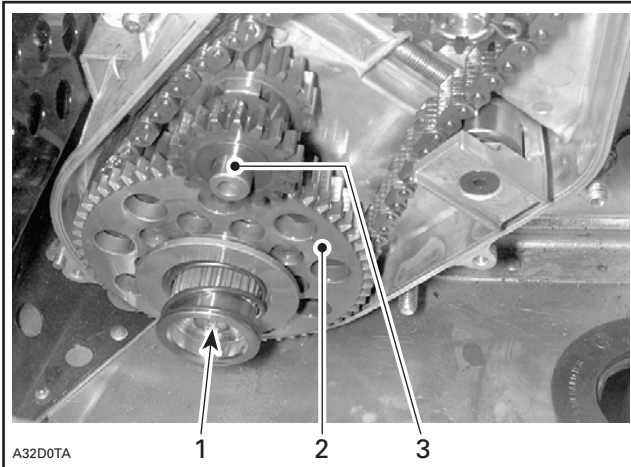

1. Retaining screw
2. Sliding gear
3. Reverse axle

Remove 19-tooth reverse gear no. 18 then remove reverse axle no. 20.

Remove coupling shaft no. 33, 44-tooth sprocket no. 34, spacer no. 38 and chain no. 28.

First unscrew castellated nut no. 10, then remove 22-tooth sprocket no. 12.

Force 2 spring pins no. 16 out to disengage fork no. 17 from its axle.

Install drive axle holder (P/N 529 007 200) before removing gearbox housing.

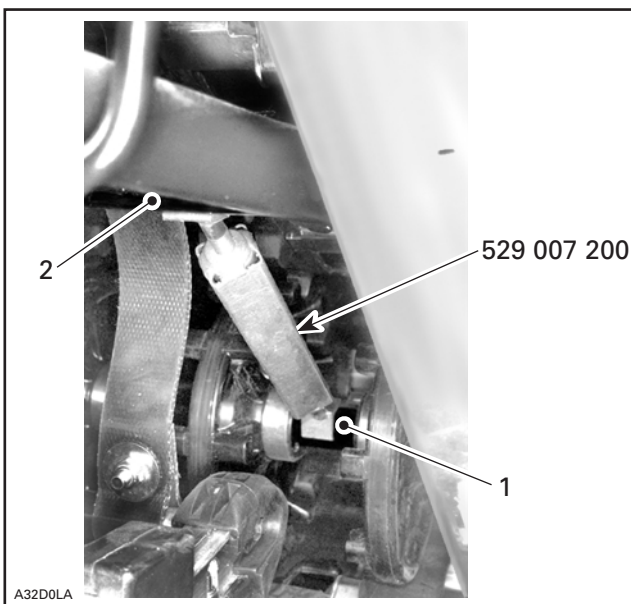

1. Drive axle
2. Suspension front arm upper axle

INSPECTION

14, Chain Slider

Replace slider if maximum wear is 1.0 mm (.039 in) at contact point.

Bearings

Check bearing condition. There must be no discoloration, missing rollers, broken cages, etc.

Sprockets and Gears

Check teeth.

ASSEMBLY

Reinstall gearbox housing.

Sealed side of bearings nos. 2 and 27 must face gearbox cover.

Do not reuse removed oil seals. Replace them with new ones.

Install bearing no. 2 and circlip in chaincase bore.

Temporary install spacer no. 38 with its large outer diameter against sprocket, 44-tooth sprocket no. 34, coupling shaft no. 33, cap no. 40 and screw no. 31.

Place a 25 cm (10 in) rule against sprockets. Maximum allowable offset is 1 mm (.040 in).

a. If upper sprocket is too far in, possible causes are:

1. Countershaft bearing on driven pulley side may be too far in. To check, pull out bearing then recheck sprocket alignment. Reposition bearing. Bearing housing (triangle) must be against frame without preload.
2. Add shim(s) between chaincase and frame and reposition bearing on driven pulley side accordingly.

b. If upper sprocket is too far out, check:

If there are too many shims between chaincase and frame. Remove shims accordingly and reposition bearing on driven pulley side.

Press needle bearing in 44-tooth sprocket. Assemble drive pins no. 35 and their spring no. 36 on 44-tooth sprocket. Tighten nut no. 37 to 5 N•m (44 lbf•in) in a criss-cross sequence.

Section 05 TRANSMISSION

Subsection 08 (GEARBOX)

Insert spring pin no. 21 in reverse axle up to inside diameter. Press needle bearing in 19-tooth sprocket. Install ring no. 24 and 19-tooth sprocket on reverse axle.

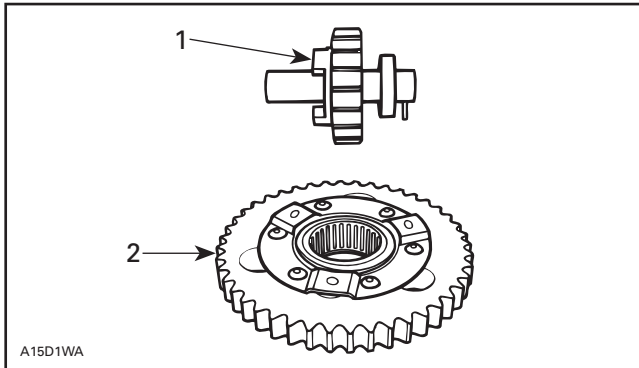

1. Reverse axle ass'y
2. Sliding gear ass'y

Install shim no. 13 and 22-tooth sprocket (drive) no. 12 then tighten castellated nut no. 10 and conical spring washer. Secure with a new cotter pin.

Install chain no. 28, 44-tooth sprocket no. 34 and its spacer no. 38. Spacer's large outer diameter must be against sprocket. Insert coupling shaft no. 32 in 44-tooth sprocket.

Install needle bearing no. 15 (wider one) in reverse gear no. 18.

Install reverse axle no. 20 (assembly) making sure to properly position spring pin in housing slot. Install alignment rod no. 19, reverse gear no. 18 and spacer no. 24. Drive sprocket hole and driven gear hole must be aligned to insert alignment rod.

Mount chain tensioner (assembly) to adjustment screw already fixed to gearbox. Assemble fork no. 17 to axle using spring pins no. 16. Apply grease on O-rings.

6, Cover

Join cover (assembly) to housing. Make sure fork tabs are behind sliding sprocket thrust washer.

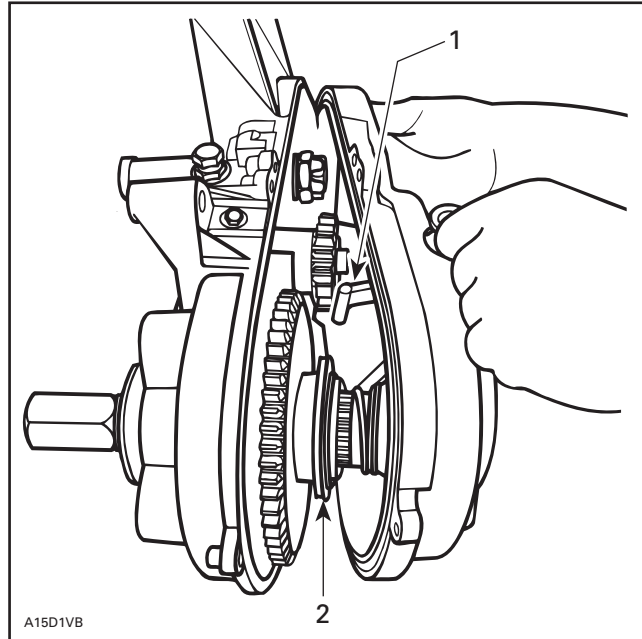

1. Fork tabs
2. Thrust washer

CAUTION: Gearbox cover must lay completely against housing.

5,7,8,39, Screws, Locking Tab and Copper Washer

Tighten screws in a criss-cross sequence starting with the one above reverse axle. Install reverse axle screw, copper washer and bend locking tab against screw head flat.

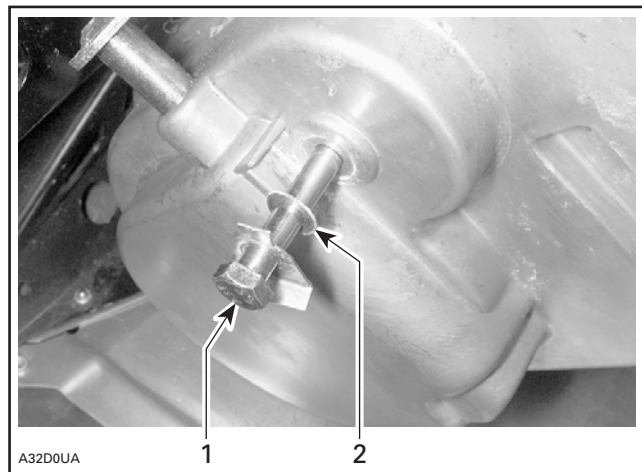

1. Reverse axle screw
2. Copper washer

Bolt tie rod to shifter.



ADJUSTMENT

28, Chain

Fully tighten adjustment screw by hand, then back off only far enough for hair pin to engage in locking hole.

4, Gear Shift Linkage

1. Check proper fit of handle in console.
2. Shift into forward gear.
3. Loosen ball joint lock nuts on the tie-rod.
4. Lengthen tie-rod until distance between upper ball joint screw head and stopper is 0 to 0.3 mm (0 to .012 in).

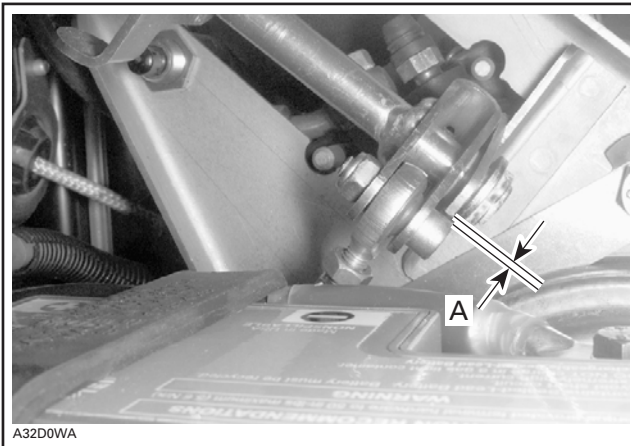

A. 0 to 0.3 mm (0 to .012 in)

NOTE: It is normal to feel a light friction when shifting into gear.

5. Statically test transmission operation in forward and reverse positions.

6. Hold linkage and tighten ball joint jam nut.

29, Alarm Switch

Adjust backup alarm switch so that buzzer sounds when transmission is in reverse gear while engine is running.

OIL CHANGE

Place a container under bottom pan (gearbox side). Remove drain plug.

NOTE: It is normal to find metallic particles stuck to dipstick magnet. If bigger pieces of metal are found, disassemble and check all parts.

Fill gearbox with Bombardier synthetic chaincase oil (P/N 413 802 800 — 12 x 250 mL). Oil capacity is 250 mL (8.5 oz).

Check oil level with dipstick. With dipstick unscrewed, oil level must be between MIN. and MAX. marks.

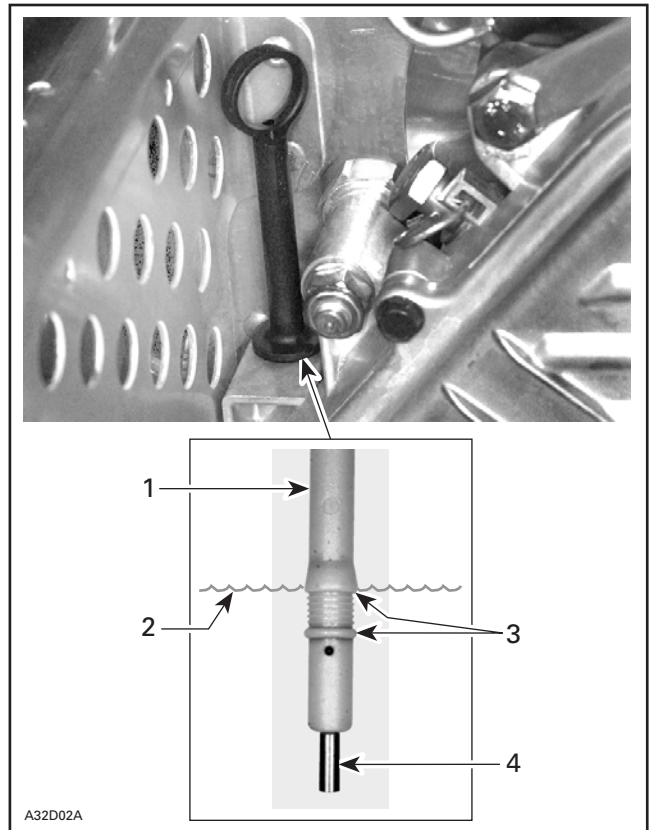

TYPICAL

1. Dipstick
2. Oil level
3. Level between marks
4. Magnet

DRIVE CHAIN

SILENT CHAIN

There are 2 types of silent chains. One is 11-plates wide and the other is 13-plates wide (stronger). Do not interchange chains. Fit chain on sprockets to make sure that you are using right one according to width. Refer to TECHNICAL DATA.

NOTE: No work (separation, lengthening) can be done on the silent chain type.