

TABLE OF CONTENTS

CLUTCH	05-02-1
REMOVAL	05-02-2
DISASSEMBLY	05-02-3
CLEANING	05-02-3
INSPECTION	05-02-3
INSTALLATION.....	05-02-4

BRAKE	05-03-1
REMOVAL	05-03-2
DISASSEMBLY	05-03-2
CLEANING	05-03-2
INSPECTION	05-03-3
INSTALLATION.....	05-03-3
ADJUSTMENT.....	05-03-4

DRIVE CHAIN	05-04-1
REMOVAL.....	05-04-1
INSPECTION	05-04-1
INSTALLATION.....	05-04-1
LUBRICATION.....	05-04-1

CLUTCH

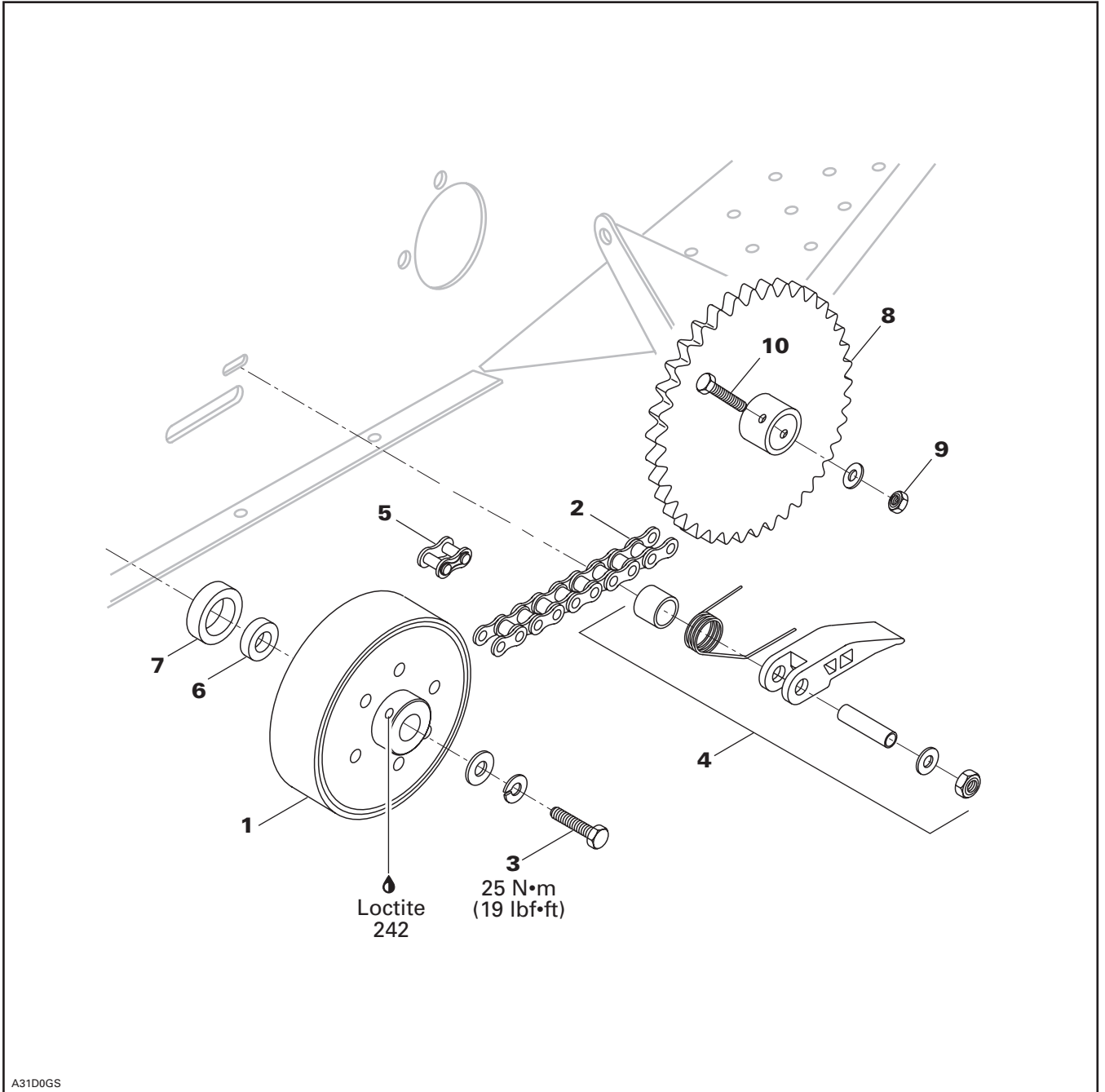

A31D0GS

Section 05 TRANSMISSION

Subsection 02 (CLUTCH)

NOTE: Parts are not available separately. If clutch no. 1 is damaged, replace clutch assembly.

REMOVAL

NOTE: Clutch can be removed without removing brake. In that case drive chain no. 2 must be separated and removed first.

Lift hood.

Remove chain guard retaining screws as shown in the following photo and lift off guard.

WARNING

When removing chain guard, ensure that engine is not running. Serious injuries may occur.

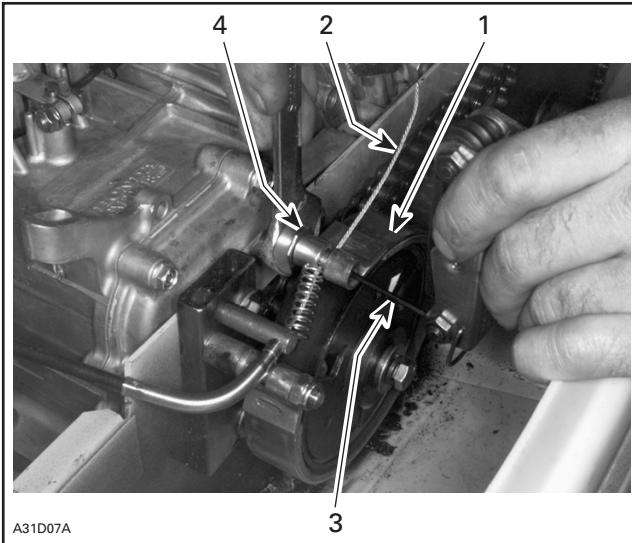

UNLOCK BRAKE CABLE FROM BRAKE PAD

1. Brake pad
2. Brake cable
3. Unlock brake cable using Allen key
4. Hold screw head

Pull out brake cable from brake pad.

Remove elastic nut from pivot screw, then pull out brake pad.

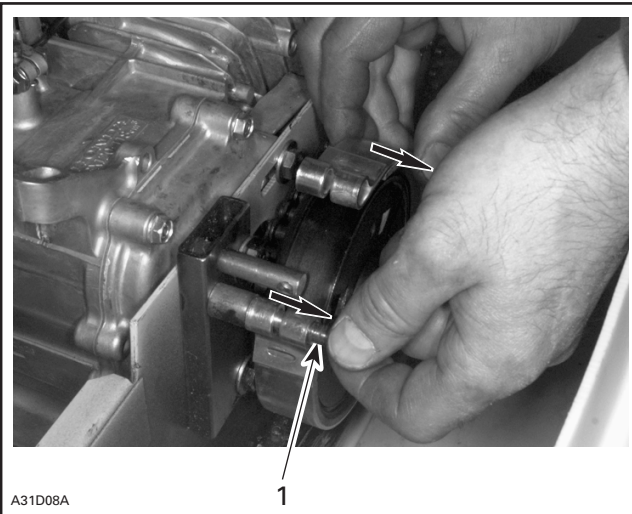

REMOVE BRAKE PAD

1. Pivot screw

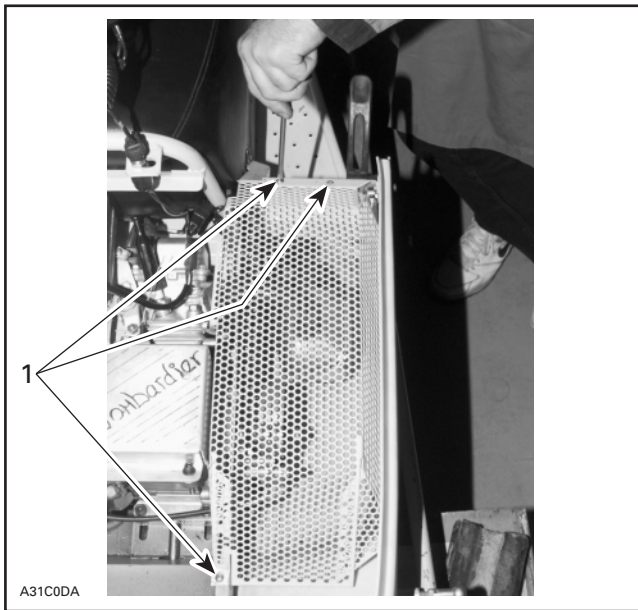

1. Using a screwdriver, remove 3 screws

Brake Pad Removal

Using Allen key, unlock brake cable from brake pad, as shown in the next photo.

1, Clutch Removal

Holding clutch with a wrench, loosen clutch retaining screw no. 3.

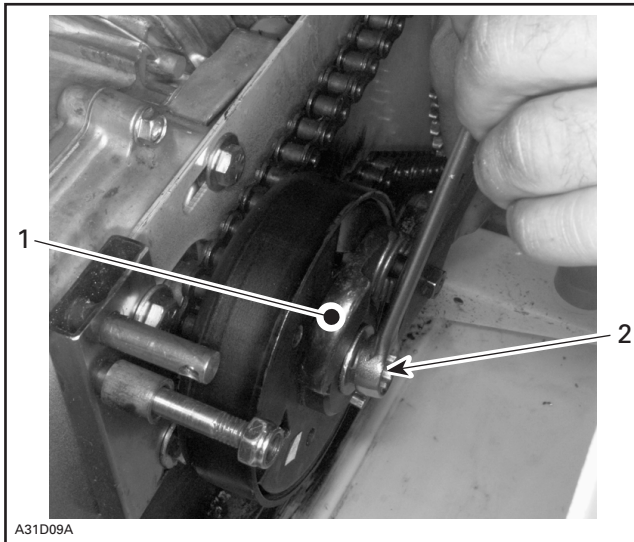

LOOSEN CLUTCH SCREW

1. Wrench
2. Clutch retaining screw

Remove drive chain automatic tensioner ass'y no. 4.

Remove drive chain from drive sprocket.

NOTE: To ease drive chain removal, chain can be separated by removing connecting link no. 5, as described in subsection 04 DRIVE CHAIN.

Remove clutch with extension no. 6 and spacer no. 7.

8, Driven Sprocket Removal

NOTE: To ease drive chain and driven sprocket no. 8 removal and installation, it may be useful to remove footrest.

Remove drive chain from driven sprocket.

Loosen driven sprocket locking nut no. 9, then remove driven sprocket screw no. 10.

Pull out driven sprocket from drive axle.

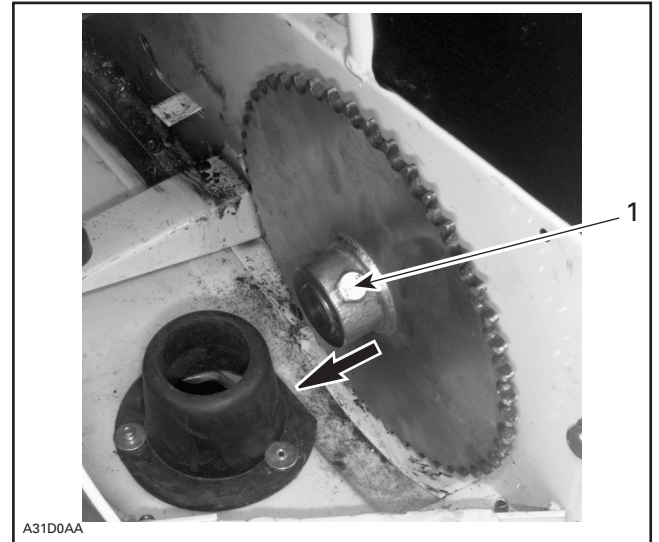

REMOVE DRIVEN SPROCKET

1. Loosen driven sprocket locking screw

DISASSEMBLY

Parts are not available separately. If clutch is damaged, replace clutch assembly.

CLEANING

Clean all metal components in a general purpose solvent. Thoroughly dry all components before assembling.

INSPECTION

Inspect drive sprocket for wear. If sprocket is worn, replace clutch ass'y with new one.

If so check if clutch components are loose. If so, replace clutch ass'y with new one.

Section 05 TRANSMISSION

Subsection 02 (CLUTCH)

INSTALLATION

To install clutch, reverse removal procedure paying attention to the following.

Pour a few drops of oil into clutch sleeves, as shown in the next illustration.

CAUTION: Pour a few drops of oil on clutch axle only. Do not spill oil into clutch mechanism or on clutch cover (braking surface).

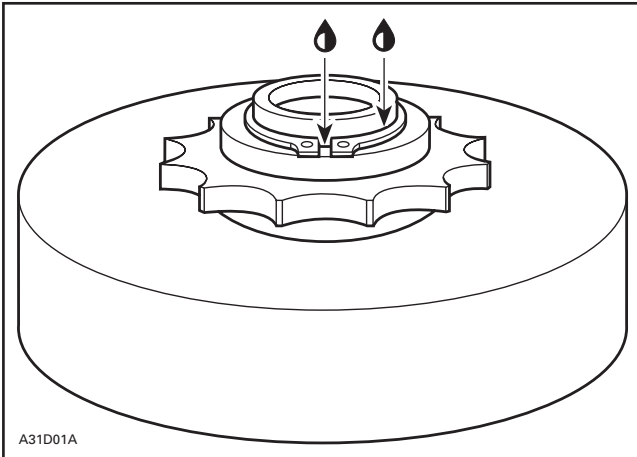

DRIP A FEW DROPS OF OIL ON CLUTCH AXLE

To ease sprocket and clutch installation, first install drive chain on both sprockets. Slide clutch and driven sprocket on shafts, as per following photo.

CAUTION: Ensure that keyway is properly positioned when sliding clutch on shaft.

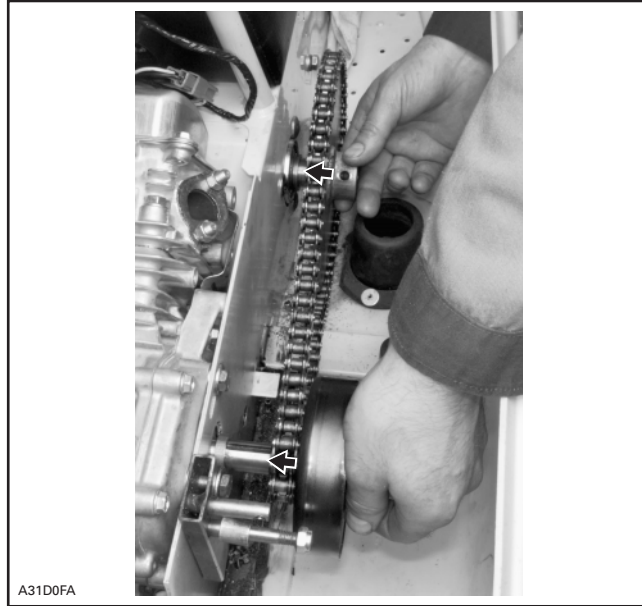

SLIDE CLUTCH AND DRIVEN SPROCKET

Secure clutch and driven sprocket.

Reinstall automatic drive chain tensioner.

BRAKE

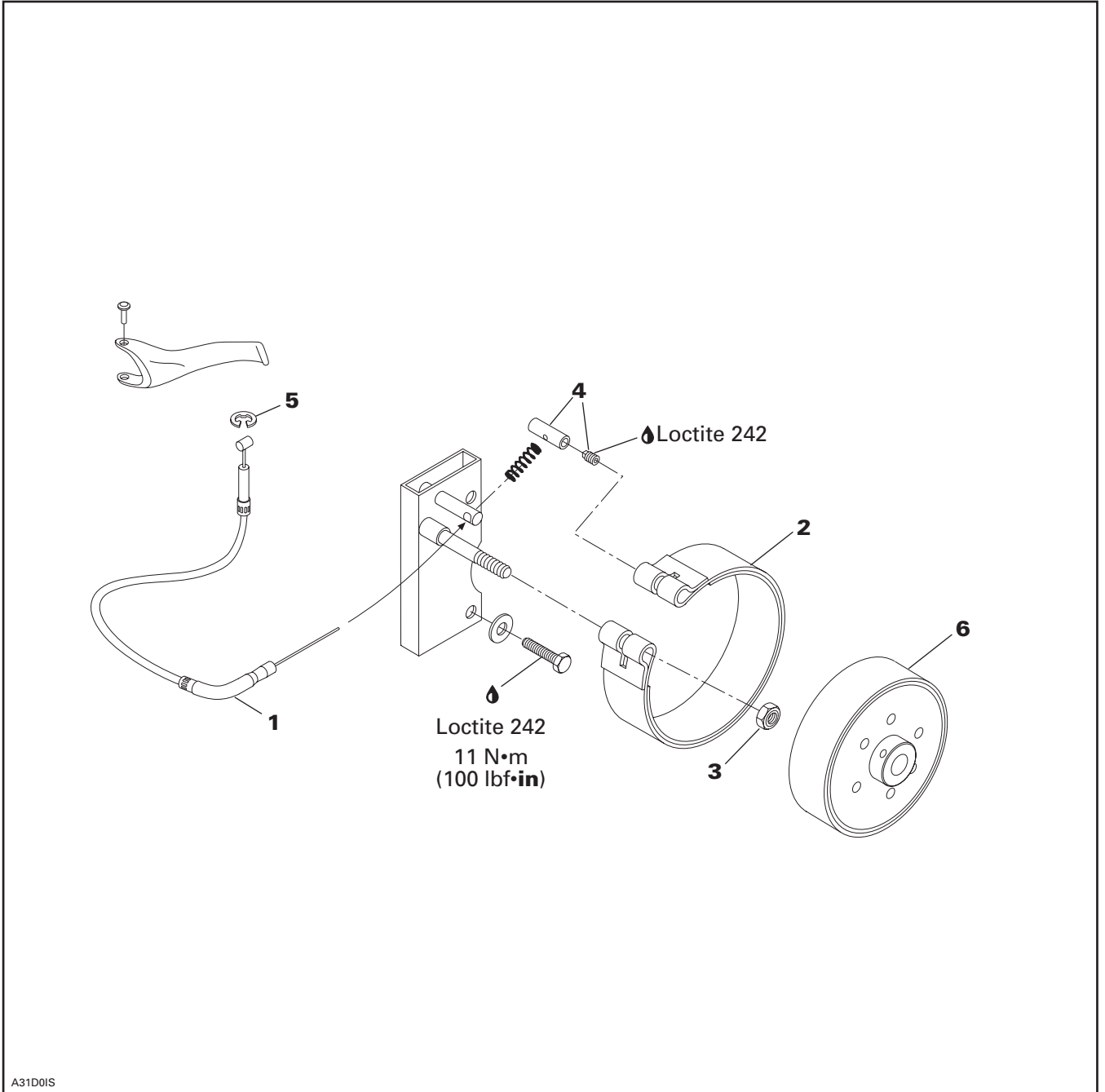

Section 05 TRANSMISSION

Subsection 03 (BRAKE)

REMOVAL

2, Brake Pad Removal

Using Allen key, unlock brake cable **no. 1** from cable lock **no. 4**, as shown in the next photo.

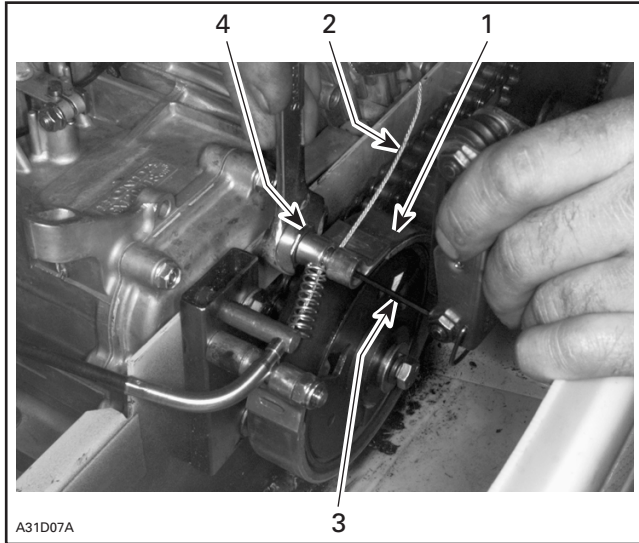

UNLOCK BRAKE CABLE FROM BRAKE PAD

1. Brake pad
2. Brake cable
3. Unlock brake cable using Allen key
4. Hold screw head

Pull out brake cable from cable lock.

Remove elastic nut **no. 3** from pivot screw, then pull out brake pad **no. 2**.

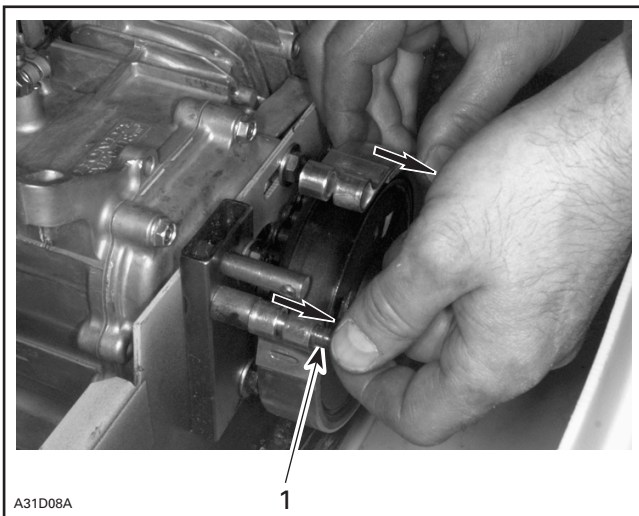

REMOVE BRAKE PAD

1. Pivot screw

Brake Cable Replacement

Remove circlip **no. 5** from brake cable at brake lever location, as shown in the next photo.

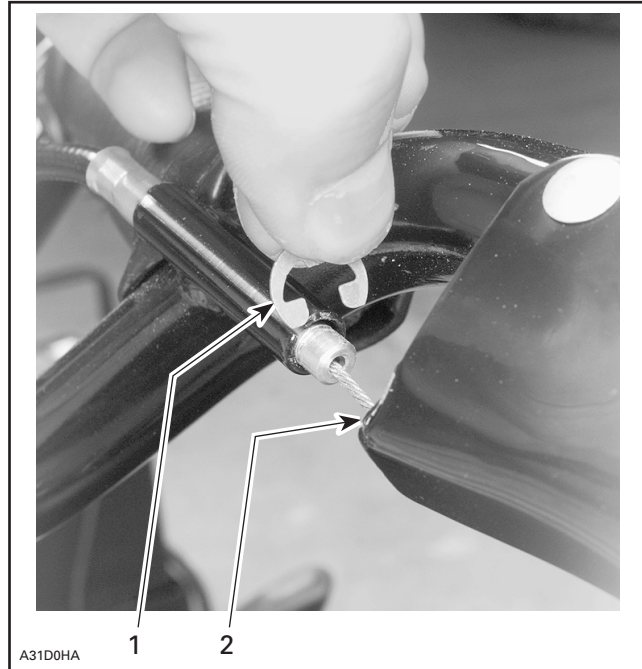

1. Circlip
2. Detach brake cable from brake lever

Detach brake cable from brake lever.

Remove cable and replace with new one.

DISASSEMBLY

Only brake pad **no. 2** is available as spare part. If clutch cover braking surface is damaged or worn, replace clutch ass'y **no. 6**.

CLEANING

Clean all metal components in a general purpose solvent. Thoroughly dry all components before assembling.

CAUTION: Do not clean brake pad in solvent. Soiled brake pad must be replaced by new one.

INSPECTION

2, Brake Pad

Brake pad must be replaced when lining is 1 mm (1/32 in) thick or less.

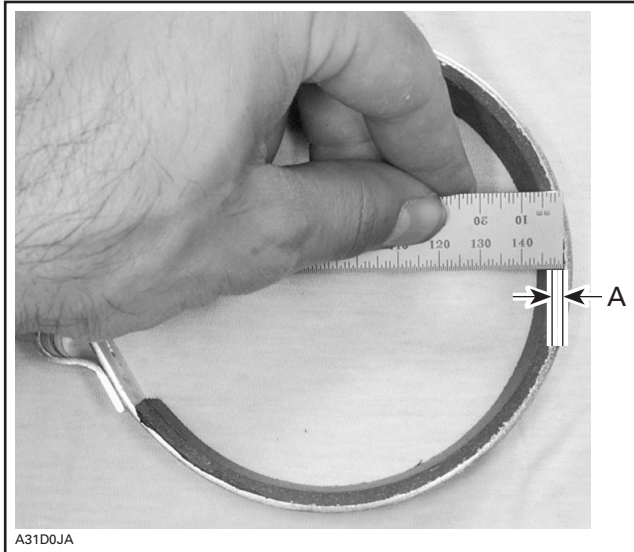

A. 1 mm (1/32 in) minimum

6, Brake Drum (clutch cover)

Inspect brake drum surface in clutch cover for scoring, wear or cracking.

If brake drum needs to be replaced, replace clutch assembly with new one.

INSTALLATION

To install brake pad, reverse removal procedure paying attention to the following.

When securing brake pad with elastic nut **no. 3**. Stop tightening when nut leans against brake pad. This will avoid brake pad damage.

⚠ WARNING

Avoid getting oil on brake pad.

Check that brake lever is set to normal position (no play), as shown in the next photo.



1. No play here

Using pliers, secure brake cable so that brake pad slightly rests on clutch cover.

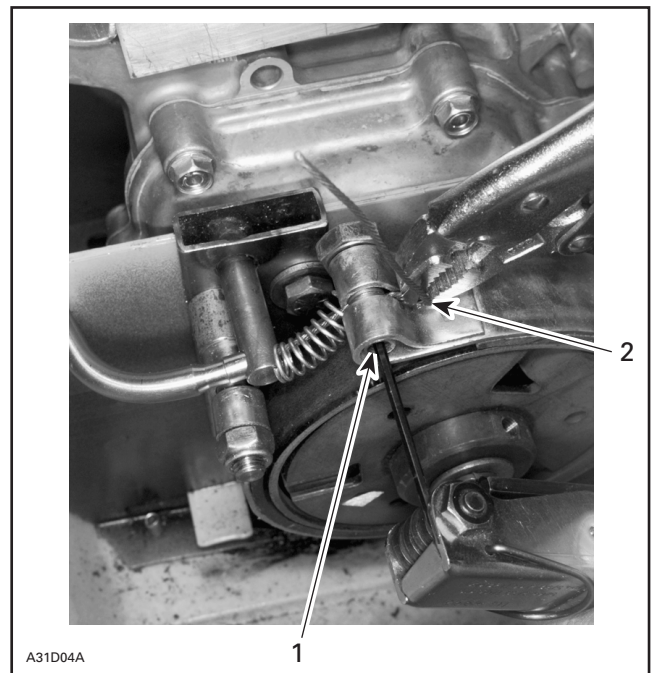

1. Tighten Allen screw
2. Pull brake cable with pliers

Section 05 TRANSMISSION

Subsection 03 (BRAKE)

ADJUSTMENT

Fully apply brake with brake lever. If brake lever is not within 15 mm (19/32 in) to 20 mm (25/32 in) of the handlebar, readjust brake. Refer to the following photo.

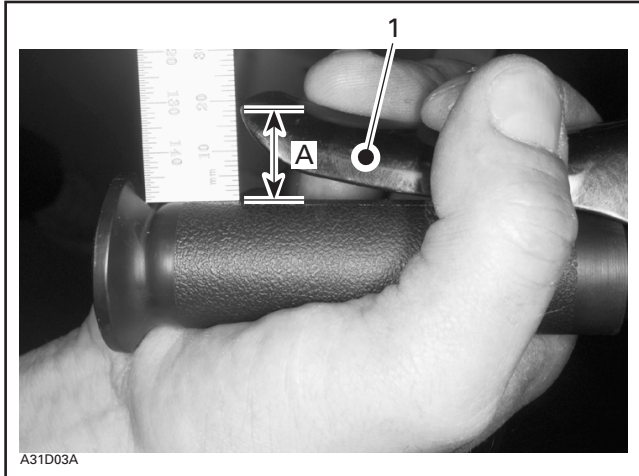

1. Brake lever

A. If measurement is not within 15 mm (19/32 in) to 20 mm (25/32 in), readjust brake

To adjust brake, loosen Allen screw then pull or push on brake cable.

Retighten cable lock Allen screw.

Finally check brake adjustment.

DRIVE CHAIN

REMOVAL

NOTE: To ease drive chain removal, remove drive chain automatic tensioner first.

Rotate drive chain to locate connecting link circlip.

Using a flat screwdriver push on both ends of circlip to remove it.

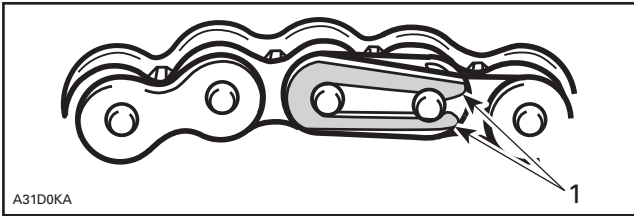

REMOVE CIRCLIP

1. Using a screwdriver, push circlip here

Remove outer link.

Detach drive chain by removing connecting link.

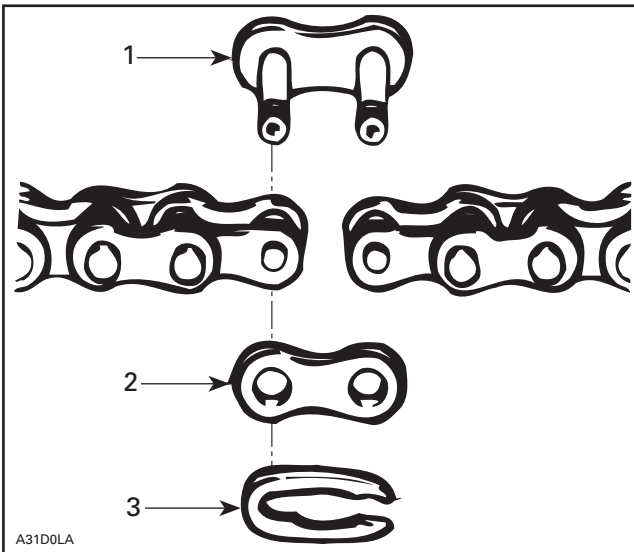

1. Connecting link
2. Outer link
3. Circlip

Keep circlip, outer link and connecting link.

INSPECTION

Check that chain is not stretched.

CAUTION: On a stretched chain, pitch has changed (increased) and will not properly match the sprockets pitch, causing premature wear. For that reason, a stretched chain must never be shortened.

Visually inspect chain for cracked, damaged or missing links.

Check for worn or defective bearings, sprockets and chain tensioner components.

INSTALLATION

Reinstall drive chain on both sprockets.

Join both drive chain ends using connecting link.

Secure connecting link using outer link and circlip.

Install circlip so that open end is positioned opposite side of drive chain rotation. See the following illustration.

⚠ WARNING

Always ensure that connecting link, outer link and circlip are in good condition. Ensure that circlip is properly secured.

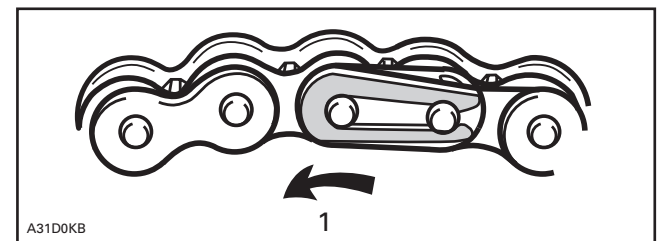

TYPICAL

1. Rotation

Reinstall drive chain automatic tensioner.

LUBRICATION

Lubricate drive chain as per lubrication chart.

Use BOMBARDIER LUBE (P/N 293 600 016).

CAUTION: Always lubricate drive chain slightly. Oil must not contact brake pad.