



**ELECTRIC STARTER KIT
(P/N 861 771 300)**

◆ WARNING

For safety reasons, this kit must be installed by an authorized Bombardier snowmobile dealer. Should removal of a locking device be required when undergoing disassembly/assembly, always replace with a new one. This instruction sheet should be given to the purchaser. This kit is designed for specific applicable models only. It is not recommended for units other than those for which it was sold.

NOTE: Installation time is approximately 2.5 hours.

PARTS TO BE INSTALLED

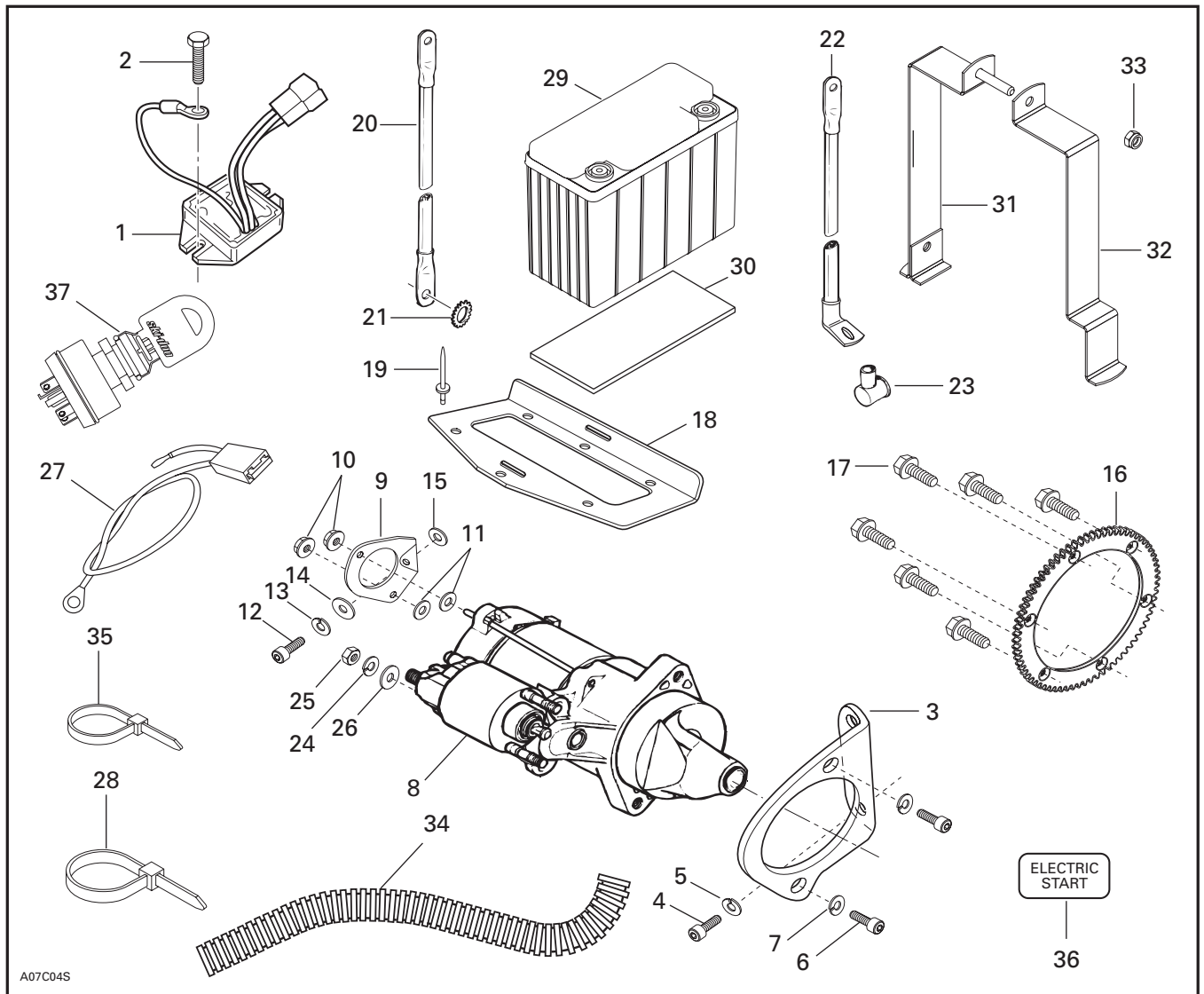

1. Voltage Regulator
2. Hexagonal Self-Tapping Screw M6 X 16 (2)
3. Starter Support PTO
4. Socket Screw M8 X 20 (2)
5. Lock Washer M8 (2)
6. Socket Screw M8 X 25 (2)
7. Lock Washer M8 (2)
8. Starter
9. Starter Support MAG
10. Flanged Elastic Nut M5 (2)
11. Flat Washer (2)
12. Socket Screw M8 X 20
13. Lock Washer M8
14. Flat Washer M8
15. Hardened Washer (2)
16. Ring Gear
17. Hexagonal Self-Tapping Screw M8 X 16 (6)
18. Battery Seat
19. Rivet (6)
20. Battery Ground Cable (BLACK)
21. Lock Washer (star)
22. Battery Positive Cable (RED)
23. Protector Cap (2)
24. Lock Washer M8
25. Hexagonal Nut M8
26. Flat Washer M8
27. Fuse Holder
28. Locking Tie (8)
29. Battery
30. Rubber Strip
31. Welded Steel Strip
32. Steel Strip
33. Flanged Elastic Nut
34. Protector
35. Locking Tie
36. Decal
37. Ignition Switch

VEHICLE PREPARATION

Battery

NOTE: Refer to appropriate *Ski-Doo Shop Manual* for proper battery removal/installation procedure.

Battery must be charged prior to installing this electric starter kit.



WARNING

Never charge or boost battery while connected or installed in vehicle.

Vehicle

Close fuel shut off valve, if equipped.

Remove exhaust system, belt guard and drive belt.

Unfasten spark plug cables from fan housing. Unplug spark plug caps.

Unplug electronic box harness underneath carburetors by inserting a screwdriver in connector tab and pull tab as illustrated.

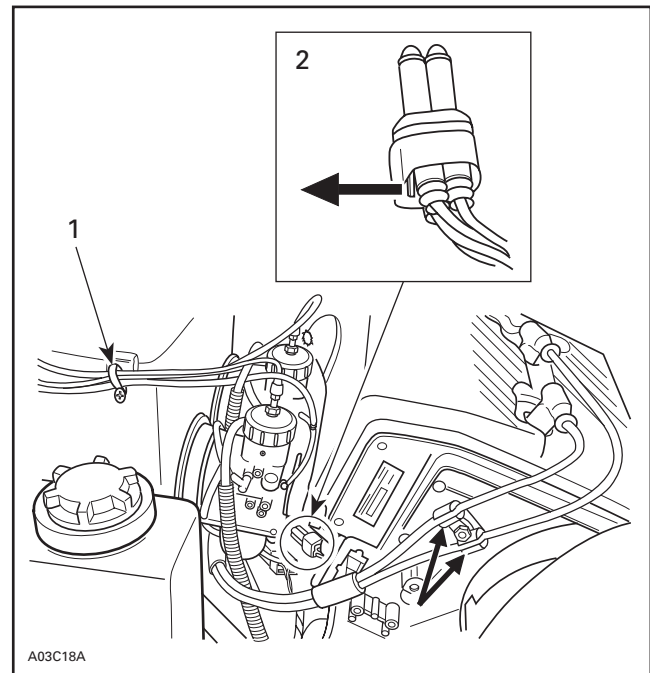

1. Plastic clip
2. CDI box harness connector

Open plastic clip that is positioned on air intake silencer. Insert a flat tip screw driver and turn as illustrated.

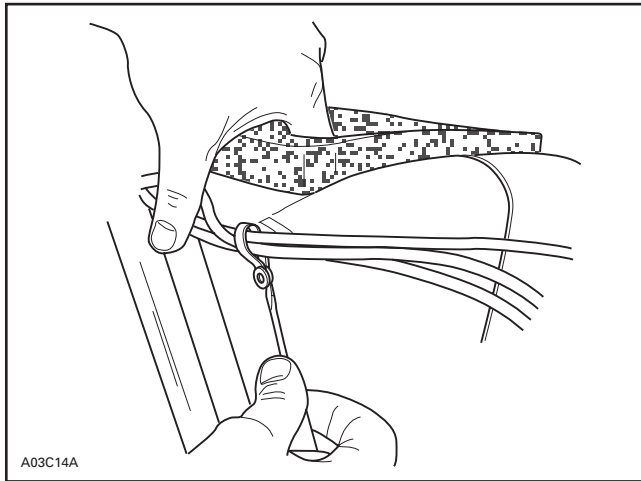

Remove air intake silencer.

INSTALLATION

Voltage Regulator

1. Remove original regulator/rectifier, located along RH side member of frame. Secure voltage regulator **no. 1** on both sides using self tapping screws **no. 2** as well as connecting ground wire from voltage regulator as shown.

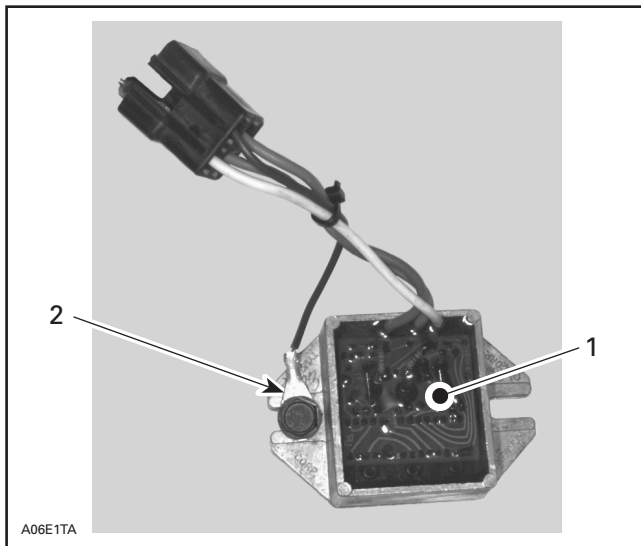

1. Voltage regulator
2. Connect ground wire here

2. Apply silicone dielectric grease (P/N 413 701 700) in voltage regulator 4-connector housing as well as vehicle harness 4-connector housing and plug them together.

Ring Gear

Remove drive pulley. Refer to *Shop Manual* to perform drive pulley disassembly/assembly procedures and to proceed with pulley alignment.

Secure ring gear **no. 16** on inner half using 6 self tapping screws **no. 17**. Apply Loctite 271 (red) on screw threads.

 CAUTION
Loctite 271 (red) must be applied to properly assemble the ring gear.

Torque screws to 11 N•m (97 lbf•in) in a criss-cross sequence.

Do not reinstall drive pulley at this time.

Ignition Switch

Cut locking tie and unplug switch connector housing from ignition switch. Insert shortest wire of fuse holder **no. 27** inside switch connector housing. Insert connector in position number 7 on switch connector housing. Reposition connectors respecting vehicle connector code as illustrated.

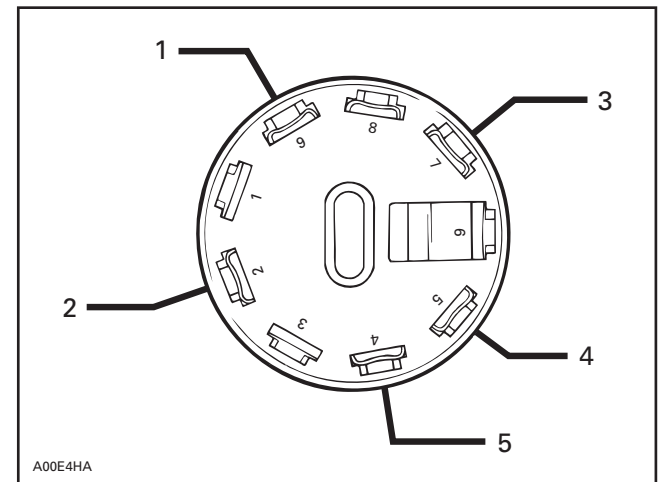

1. RED/GREEN wire to solenoid
2. BLACK/YELLOW
3. RED wire with fuse to battery
4. BLACK
5. RED/BLUE

Remove existing ignition switch and install ignition switch **no. 37**.

Replug switch connector housing to ignition switch and secure wires with a locking tie **no. 28** as shown.

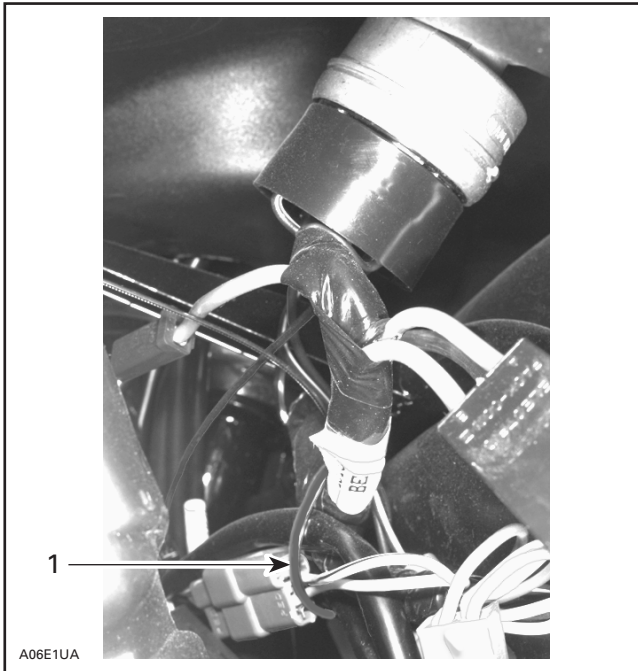

1. Locking tie

Wire/Cable Connections and Routing

Ensure that one connector of RED positive battery cable **no. 22** is straight and other connector is bent to 60°. Bend or straighten as necessary.

Starting from battery location, route battery cable along vehicle harness to starter location.

The straight connector will be connected to battery.

NOTE: Route battery cables through free bracket underneath countershaft as illustrated.

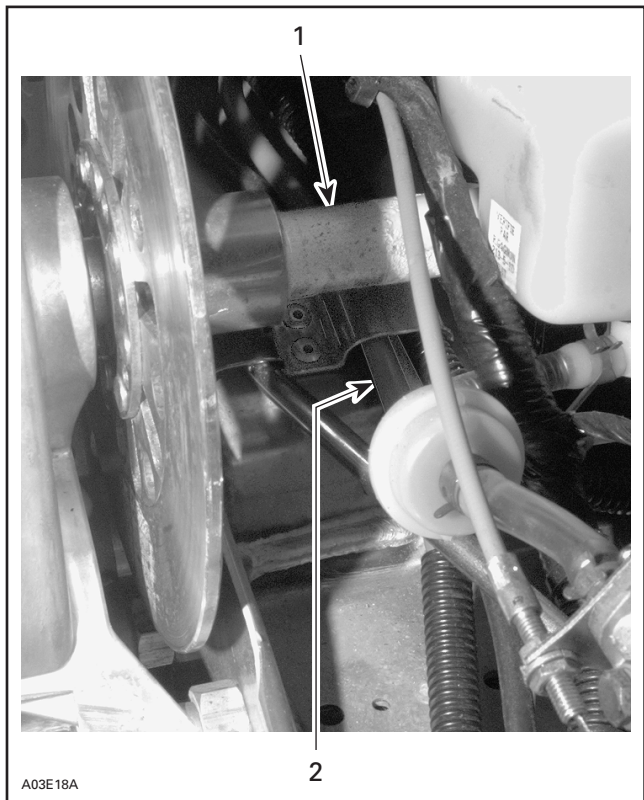

1. Countershaft
2. Battery cables underneath bracket

Install BLACK battery ground cable **no. 20** with star lock washer **no. 21** to rewind starter. Secure with existing rewind starter bolt. Refer to following illustration for proper cable positioning.

NOTE: Connect BLACK ground cable in specified order. Position star washer first then BLACK ground cable and tighten with original screw.

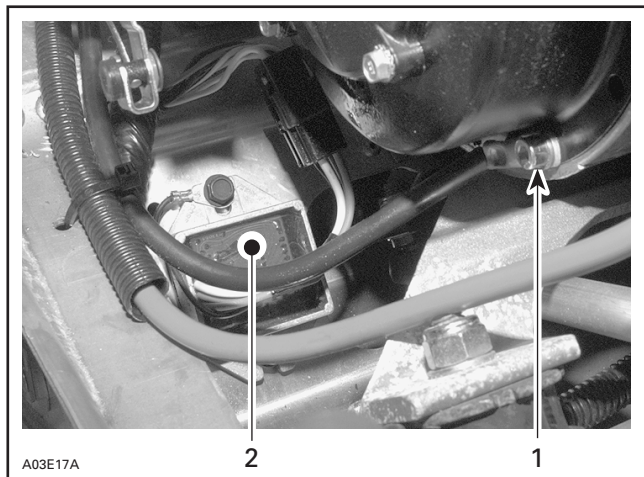

1. Connect BLACK ground cable here
2. Regulator

Electric Starter

▼ CAUTION

Apply Loctite 271 (red) on all fastener threads of starter supports.

Install starter support no. 3 (PTO side) to engine using socket screws no. 4 and lock washers no. 5. Tighten firmly.

Install electric starter no. 8 on support. Secure bottom first and then top using socket screws no. 6 and lock washers no. 7.

Install washers no. 11 over nuts of starter through bolts (MAG side).

Install starter support no. 9 (MAG side) to starter and secure with flanged elastic nuts no. 10.

If necessary, install hardened washer(s) no. 15 to fill gap between support and engine. Secure support to engine with washer no. 14, lock washer no. 13 and screw no. 12.

Install cable protector no. 34 then slide protector cap no. 23 onto RED battery cable no. 22. Bend terminal to fit. Install RED cable on starter with washer no. 26, lock washer no. 24 and nut no. 25. Cover starter terminal with protector cap. Install locking tie as shown.

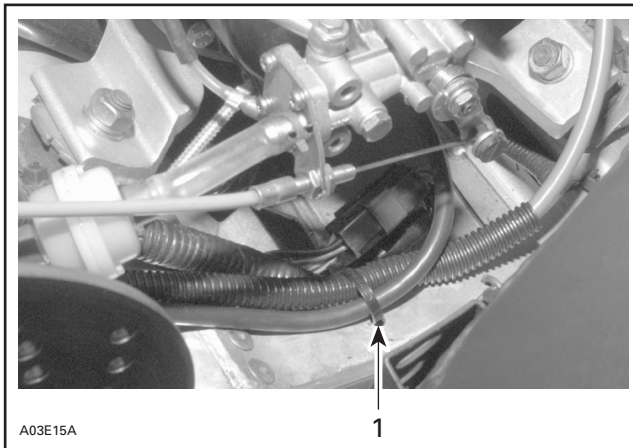

1. Locking tie

Cut locking tie that is retaining RED/GREEN wire to wiring harness beneath engine.

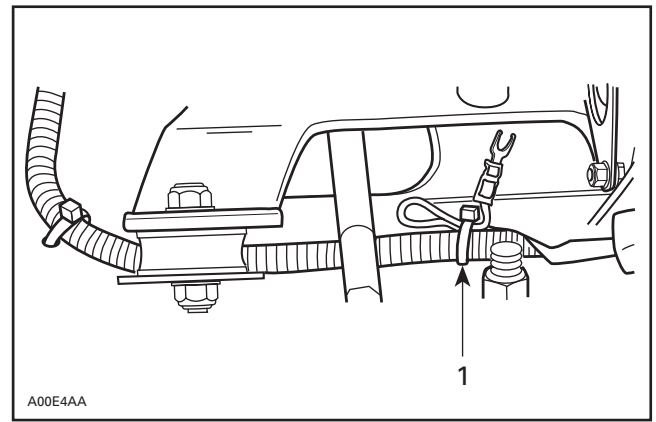

1. Cut locking tie

Connect RED/GREEN wire to small post on solenoid. Position connector under lock washer.

Secure cables loosely to rear bracket with a locking tie no. 28, as illustrated.

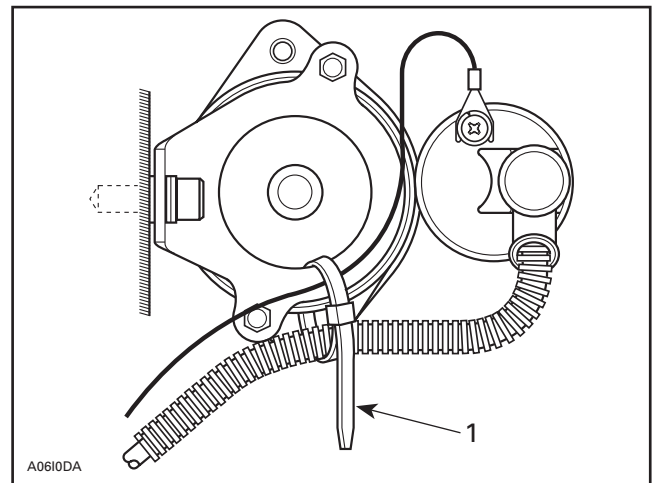

1. Tie loosely

Pull excess amount of cable from underneath engine.

Battery and Rack

▼ CAUTION

Cover carburetor intakes with a clean rag during the following drilling operation.

Drill 6 holes in chassis with a 5.2 mm (13/64 in) drill bit as shown in following illustration. Use existing holes in chassis as a guide.

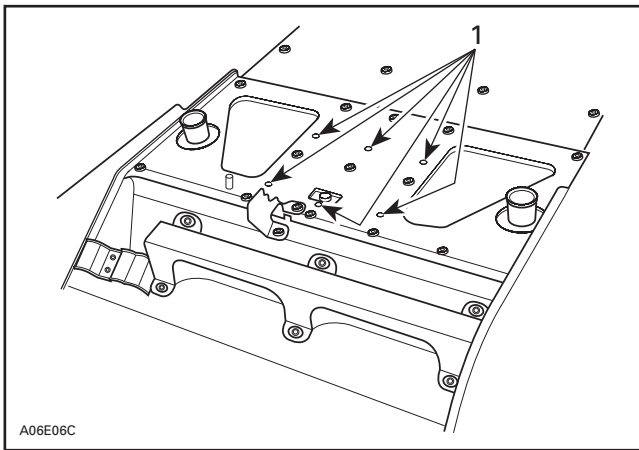

1. Drill 5.2 mm (13/64 in) holes

Secure battery seat no. 18 with 6 rivets no. 19. Install rubber strip no. 30 and battery no. 29 on seat. Insert protector cap no. 23 onto RED positive cable. Connect battery RED positive cable and RED wire with fuse from ignition switch to battery, cover post with protector cap, THEN connect BLACK ground cable. Secure cables on top of battery posts.

◆ WARNING

Always connect the battery cables exactly in the specified order. Connect RED positive cable first, then BLACK negative ground cable.

FINALIZING INSTALLATION

NOTE: Refer to appropriate *Ski-Doo Shop Manual* for proper reinstallation procedure.

Reinstall drive pulley.
Check pulley alignment.

◆ WARNING

Drive pulley alignment must always be checked whenever pulleys have been removed, replaced or disassembled.

Reinstall remaining removed parts.

Decal

Clean decal area with soapy water or isopropyl alcohol using a soft clean cloth and dry thoroughly.

▼ CAUTION

Do not apply isopropyl alcohol on decal.

Remove backing from decal.
Apply decal no. 36 as shown.

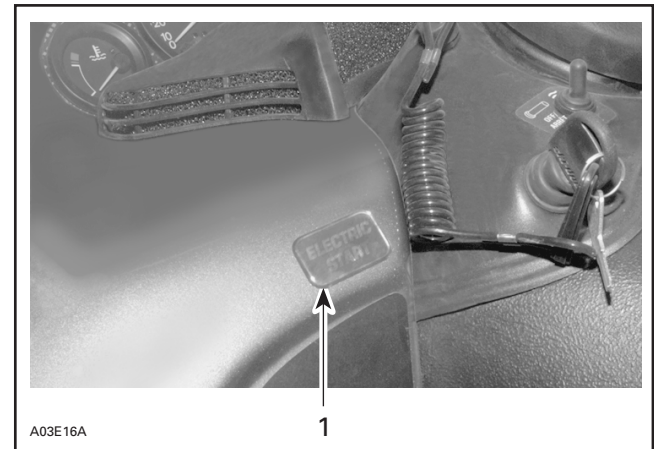

1. Decal

Install strips no. 31 and no. 32 and secure with flanged elastic nut no. 33. Route RED battery cable and RED wire through indentation on front battery strip. Fasten battery cables using a locking tie no. 35.

◆ WARNING

Ensure all terminals are properly crimped on wires/cables and that all connector housings are properly fastened. Keep wires away from any rotating, moving, heating or vibrating parts as well as from sharp edges. Use proper fastening devices as required.

861 771 300

1.	515 163 900	Voltage Regulator	Régulateur de tension
2.	210 261 680	Hexagonal Self-Tapping Screw M6 X 16 (2)	Vis autotaraudeuse à tête hexagonale M6 X 16 (2)
3.	420 951 692	Starter Support PTO	Support de démarreur (côté PDM)
4.	205 082 044	Socket Screw M8 X 20 (2)	Vis à tête creuse M8 X 20 (2)
5.	420 945 752	Lock Washer M8 (2)	Rondelle-frein M8 (2)
6.	205 082 544	Socket Screw M8 X 25 (2)	Vis à tête creuse M8 X 25 (2)
7.	234 181 401	Lock Washer M8 (2)	Rondelle-frein M8 (2)
8.	410 212 400	Starter	Démarreur
9.	420 951 702	Starter Support MAG	Support de démarreur (côté MAG)
10.	233 251 414	Flanged Elastic Nut M5 (2)	Écrou d'arrêt élastique à épaulement M5 (2)
11.	391 301 700	Flat Washer (2)	Rondelle plate (2)
12.	205 082 044	Socket Screw M8 X 20	Vis à tête creuse M8 X 20
13.	420 945 752	Lock Washer M8	Rondelle-frein M8
14.	234 081 410	Flat Washer M8	Rondelle plate M8
15.	503 007 900	Hardened Washer (2)	Rondelle trempée (2)
16.	414 807 500	Ring Gear	Couronne de lancement
17.	210 361 686	Hexagonal Self-Tapping Screw M8 X 16 (6)	Vis autotaraudeuse à tête hexagonale M8 X 16 (6)
18.	517 286 200	Battery Seat	Support de batterie
19.	390 402 200	Rivet (6)	Rivet (6)
20.	515 175 287	Battery Ground Cable (BLACK)	Câble de masse de la batterie (NOIR)
21.	394 001 900	Lock Washer (star)	Rondelle-frein en étoile
22.	515 175 288	Battery Positive Cable (RED)	Câble positif de la batterie (ROUGE)
23.	570 151 000	Protector Cap (2)	Capuchon de protection (2)
24.	420 945 752	Lock Washer M8	Rondelle-frein M8
25.	232 081 414	Hexagonal Nut M8	Écrou hexagonal M8
26.	234 081 410	Flat Washer M8	Rondelle plate M8
27.	515 157 300	Fuse Holder	Porte-fusible
28.	414 115 200	Locking Tie (8)	Attache (8)
29.	410 301 200	Battery	Batterie
30.	570 070 300	Rubber Strip	Bande de caoutchouc
31.	515 175 207	Welded Steel Strip	Bande d'acier soudée
32.	515 175 116	Steel Strip	Bande d'acier
33.	233 251 414	Flanged Elastic Nut	Écrou élastique à épaulement
34.	414 627 300	Protector	Protecteur
35.	748 001 001	Locking Tie	Attache
36.	418 001 300	Decal	Autocollant
37.	410 111 300	Ignition Switch	Interrupteur d'allumage