



**ELECTRIC STARTER KIT
(P/N 861 504 800)**

⚠ WARNING

For safety reasons, this kit must be installed by an authorized Ski-Doo® snowmobile dealer. Should removal of a locking device (e.g. lock tabs, self-locking fasteners, etc.) be required when undergoing disassembly/assembly, always replace with a new one. This instruction sheet should be given to the purchaser. This kit is designed for specific applicable models only. It is not recommended for units other than those for which it was sold.

NOTE: Installation time is approximately 2.5 hours.

PARTS TO BE INSTALLED

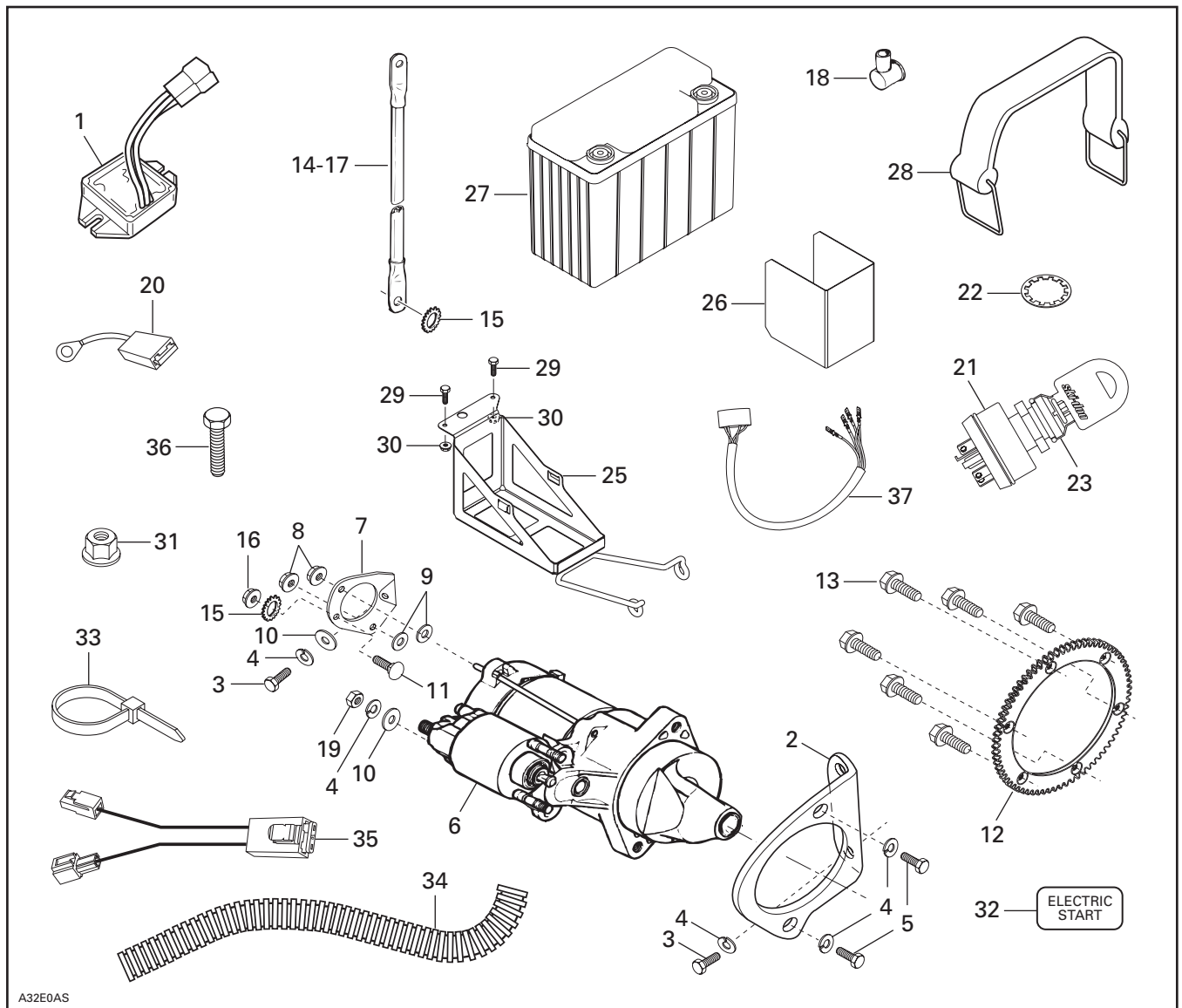

1. Regulator/Rectifier
2. Starter Support PTO Side
3. Hexagonal Screw M8 x 20 (3)
4. Lock Washer M8 (6)
5. Hexagonal Screw M8 x 25 (2)
6. Starter
7. Starter Support MAG side
8. Flanged Elastic Nut M5 (2)
9. Flat Washer M6 (2)
10. Flat Washer M8 (2)
11. Carriage Bolt M6 x 20
12. Ring Gear
13. Self-Tapping Screw M8 x 16 (6)
14. BLACK Negative Ground Cable (2)
15. Star Washer M6 (3)
16. Flanged Elastic Nut M6 (2)
17. RED Positive Battery Cable
18. Protector Cap (2)
19. Hexagonal Nut M8

20. Fuse Holder
21. Switch
22. Star Washer
23. Face Nut
24. Switch Protector (not illustrated)
25. Battery Seat
26. Deflector
27. Battery
28. Battery Strap
29. Hexagonal Screw M5 x 16 (2)
30. Elastic Stop Nut M5 (2)
31. Hexagonal Nut M10 (2)
32. Decal
33. Locking Tie (8)
34. Tubing (3 ft)
35. Fuse-Ground Harness
36. Hexagonal Screw M6 x 16
37. Switch Harness

INSTRUCTIONS

Vehicle Preparation

Remove tuned pipe, muffler, belt guard, drive belt, air intake silencer.

Loosen drive pulley retaining screw for later removal.

Regulator/Rectifier

Remove original regulator/rectifier, located along RH side member of frame. Secure regulator/rectifier **no. 1** on both sides with same self-tapping bolts. On one side, install BLACK negative ground cable **no. 14** and star washer M6 **no. 15**.

Apply silicone dielectric grease (P/N 293 550 004) in regulator/rectifier connector and then connect it to vehicle harness connector. Secure connectors with a locking tie **no. 33**.

Ignition Switch

Remove steering pad.

Remove upper screw retaining both left and right consoles.

Remove fuel tank cap and retaining ring using console tightening wrench (P/N 529 035 603).

Using template, found on the last page of the current document, properly positioned on dash, mark center hole for switch location, beside DESS connector.

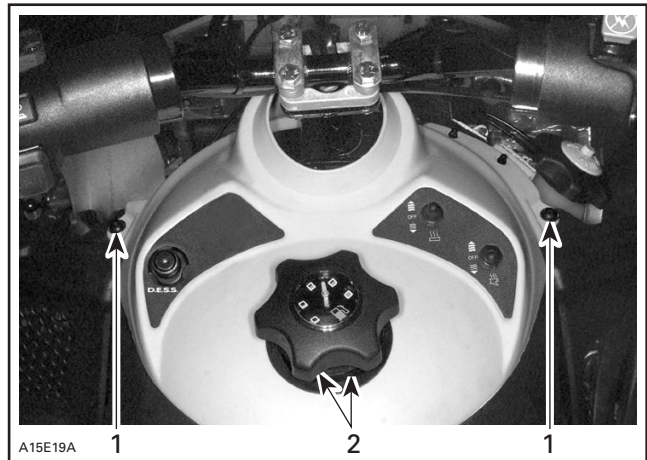

WITH STEERING PAD REMOVED

1. Remove these screws
2. Remove cap and retaining ring

Using a 19 mm (3/4 in) hole saw, drill through dash.

Tighten nut onto ignition switch **no. 21**, slide star washer **no. 22** onto switch then insert switch through hole from underneath and secure on top with face nut **no. 23**.

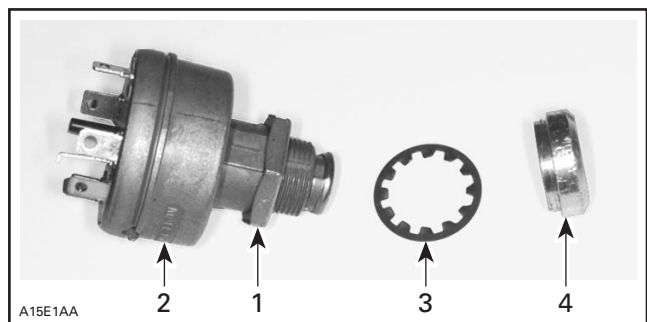

1. Nut
2. Ignition switch
3. Star washer
4. Face nut

Install rubber protector no. 24 on top of switch.

Connect switch harness no. 37 to ignition switch then, lift dash and route switch harness behind steering column but in front of heated thumb/handle connectors, leading toward multi-connector.

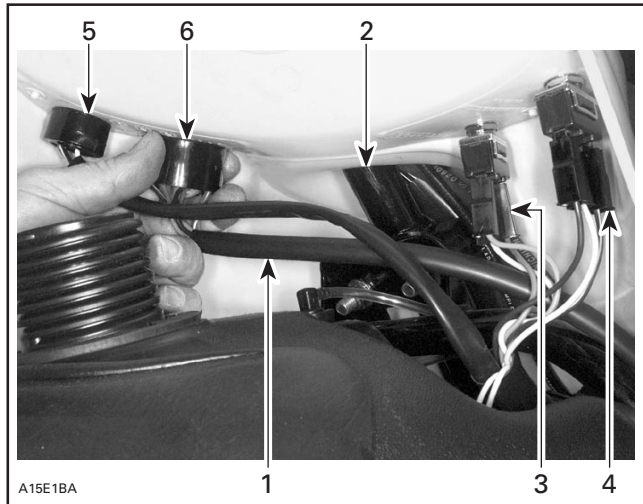

1. Fusible wiring harness
2. Steering column
3. Heated handle connector
4. Heated thumb connector
5. DESS connector
6. Ignition switch connector

Open multi-connector and insert terminals in proper holes as follows:

BLACK wire in hole no. 15;
BLACK/YELLOW wire in hole no. 14;
RED/BLUE wire in hole no. 13;
RED/GREEN wire in hole no. 11 and
RED/WHITE wire in hole no. 12.

Close multi-connector.

Reinstall console.

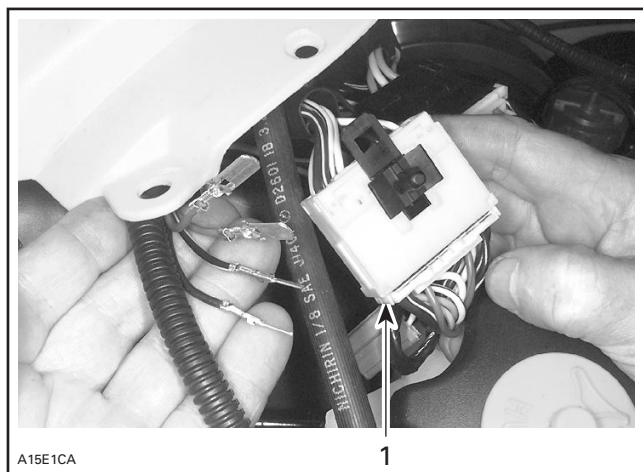

1. Use this multi-connector

Ring Gear

Remove drive pulley. Refer to appropriate *Shop Manual* to perform drive pulley disassembly/assembly procedures and to proceed with pulley alignment.

Secure ring gear no. 12 on inner half using self-tapping screws no. 13. Apply Loctite 271 (red) on screw threads.

CAUTION: Loctite 271 (red) must be applied to securely assemble ring gear.

Torque screws in a criss-cross sequence to 27 N•m (20 lbf•ft).

Do not reinstall drive pulley at this time.

Protection Fuse

Disconnect connector on hood electrical harness. See photo below.

Clip fuse-ground harness no. 35 (with fuse) on frame.

Connect fuse-ground harness wires to connector housings.

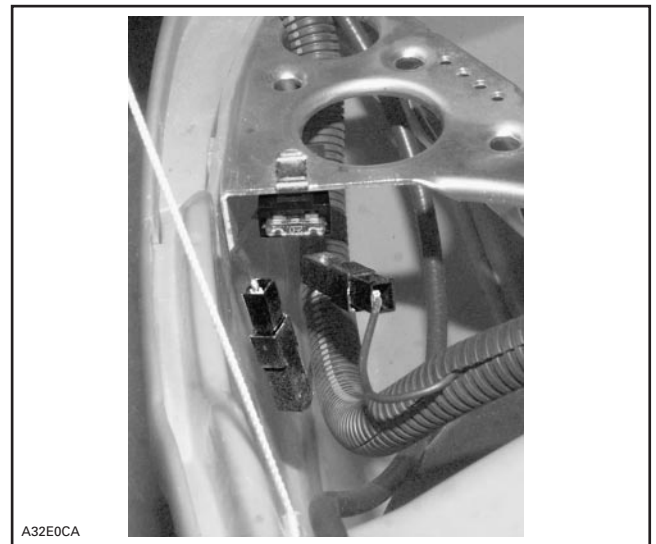

INSTALLATION COMPLETED

Electric Starter

CAUTION: Apply Loctite 271 (red) on all fastener threads of starter supports.

From main harness underneath engine cut locking tie and pull out RED wire with the eyelet terminal toward the starter position.

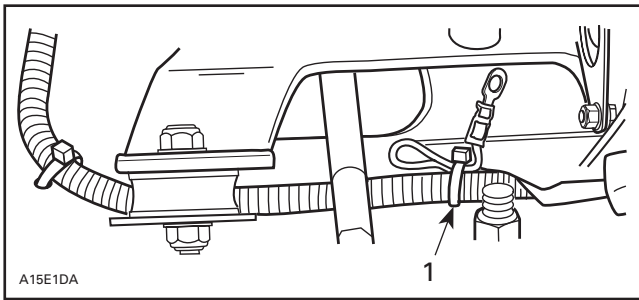

1. Locking tie

Install starter support PTO side **no. 2** to engine using hexagonal screws **no. 3** and lock washers **no. 4**. Tighten firmly.

Install electric starter **no. 6** on support, bottom bolts first and secure it using M8 x 25 hexagonal screws **no. 5** and lock washers M8 **no. 4**.

Install flat washers M6 **no. 9** over nuts of starter through bolts.

Install starter support MAG side **no. 7** to starter after inserting carriage bolt **no. 11**, and secure with M5 flanged elastic nuts **no. 8**.

Secure support to engine with M8 x 20 hexagonal screw **no. 3**, flat washer **no. 10** and lock washer **no. 4**.

Wire/Cable Connections and Routing

Starting from starter location, route RED cable **no. 17** and tubing **no. 34** toward battery location along cooling hose and between fuel tank and oil tank. The biggest hole of the RED positive cable connects to the starter.

Secure tubing with RED wire on cooling hose with locking ties **no. 33** every 150 mm (6 in) more or less.

To ease cable routing, undo coolant reservoir retaining screw just enough to push reservoir forward a bit.

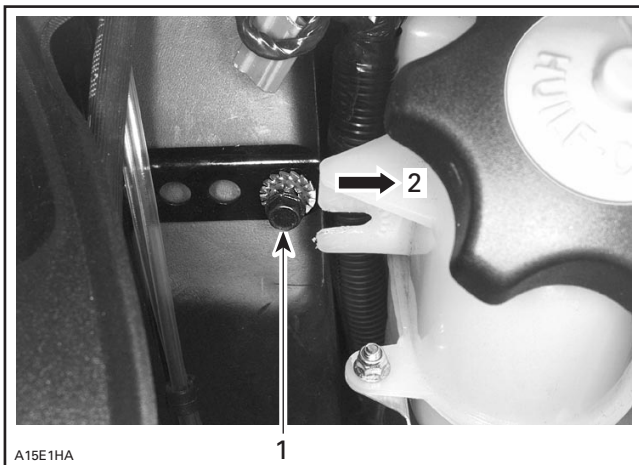

1. Loosen this bolt
2. Move a bit forward

Slide a protector cap **no. 18** (starter end of cable) and another protector cap **no. 18** (battery end of cable) on RED positive battery cable **no. 17**. Install cable, flat washer M8 **no. 10**, lock washer M8 **no. 4** and nut M8 **no. 19** to starter solenoid. Cover terminal with previously installed protector cap.

Connect and secure RED wire with eyelet terminal, previously pulled from main harness, to starter solenoid.

Connect the other side of BLACK negative cable **no. 14** coming from rectifier to starter bracket carriage bolt using star washer **no. 15** between bracket and terminal; secure with elastic nut **no. 16**.

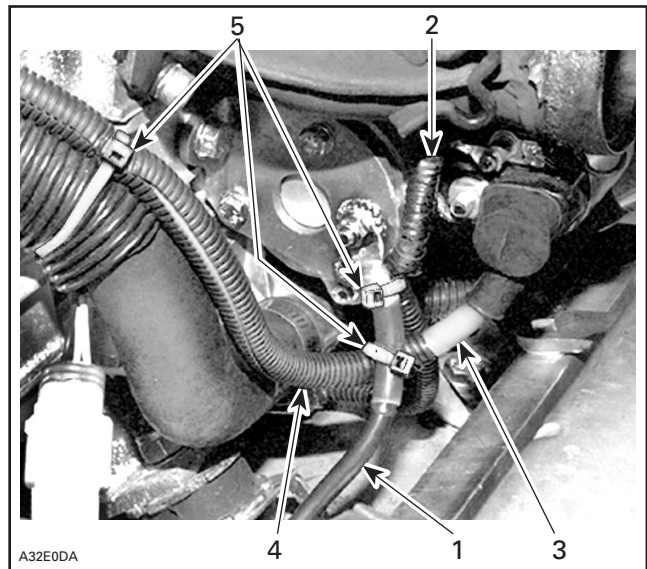

1. BLACK negative cable connected to starter support MAG side
2. RED wire with eyelet terminal connected to solenoid
3. RED positive cable connected to solenoid
4. Tubing no. 34
5. Locking ties

⚠ WARNING

Ensure all terminals are properly crimped on wires/cables and that all connector housings are properly fastened. Keep wires away from any rotating, moving, heating, vibrating and sharp edge parts. Use proper fastening devices as required.

Battery and Rack

Remove 2 lower nuts retaining chaincase cover. Install battery seat **no. 25** as shown and secure with 2 screws **no. 29** and 2 elastic nuts **no. 30** on top of right front foot rest and reinstall new chaincase cover nuts **no. 31**.

Battery Testing and Activation

Check charge condition using a multimeter.

With a multimeter, voltage readings appear instantly to show the state of charge. Always respect polarity. A fully charged battery will have a reading of 12.6 Vdc.

⚠ WARNING

Never charge or boost battery while installed on vehicle.

If not charged, connect a 10 A battery charger for few hours.

⚠ WARNING

Gases given off by a battery being charged are highly explosive. Always charge in a well ventilated area. Keep battery away from cigarettes or open flames. Always turn battery charger off prior to disconnecting cables. Otherwise a spark will occur and battery might explode.

NOTE: It is recommended to verify the battery charge once a month. If necessary, fully charge.

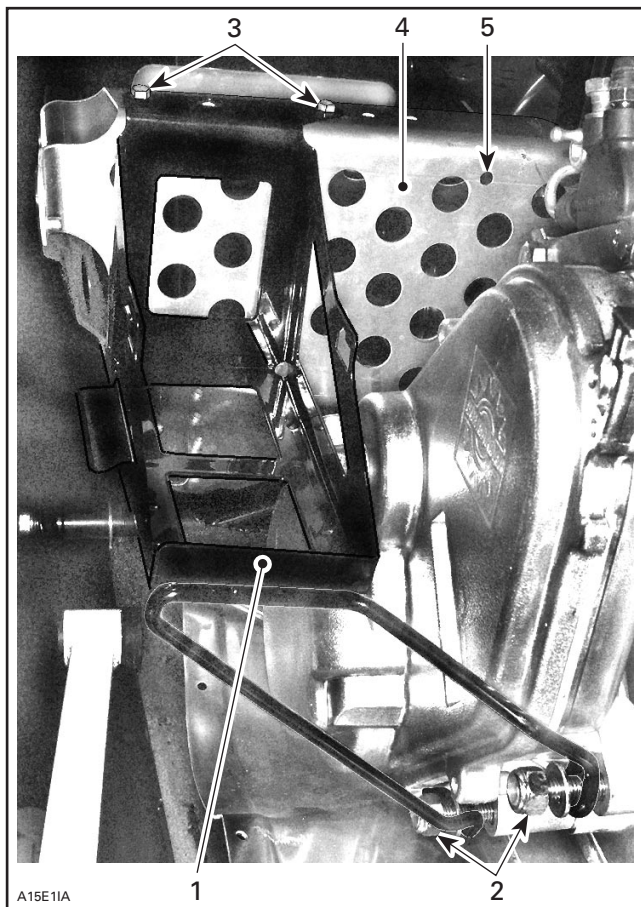

1. Battery rack
2. Change these 2 nuts
3. Secure with 2 screws no. 30 and 2 nuts no. 31
4. Footrest
5. Ground hole

Install battery no. 27 in rack, posts on engine side, with deflector no. 26.

Cut locking ties from console strand and set fuse wire RED/YELLOW into fuse holder no. 20.

Secure BLACK ground cable to footrest hole with bolt M6 no. 36, washer M6 no. 15 and nut M6 no. 16.

Connect RED positive battery cable and RED wire from fuse to battery then connect BLACK ground cable. Apply silicone dielectric grease (P/N 413 701 700) on battery posts and connectors.

⚠ WARNING

Always connect the battery cables exactly in the specified order. Connect RED positive cable first, then BLACK negative ground cable.

Secure battery in place with strap no. 28. Secure also BLACK negative cable in strap, engine side.

Hook up fuse holder to retaining RED battery cable using locking tie no. 33.

Fasten battery cables using a locking tie no. 33.

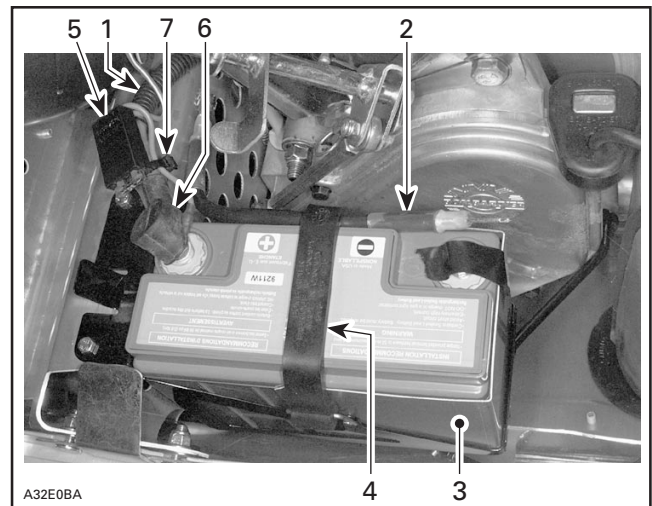

1. RED positive cable
2. BLACK negative cable
3. Deflector
4. Battery strap
5. Fuse holder
6. Protector cap
7. Locking tie

Finalizing Assembly

Refer to the appropriate *Ski-Doo Shop Manual* for proper reinstallation procedure.

Reinstall drive pulley.

Check pulley alignment.

WARNING

Drive pulley alignment must always be checked whenever pulleys have been removed, replaced or disassembled.

Reinstall remaining removed parts not forgetting to secure coolant reservoir retaining screw.

NOTE: Apply Dow Corning sealer no. 736 RTV on exhaust manifold ball joint.

Test electrical starting and ignition cut-out systems as per normal starting procedure for electric starter models.

Decal

Clean decal region with soapy water or isopropyl alcohol using a soft clean cloth and dry thoroughly.

CAUTION: Do not apply isopropyl alcohol on decal.

Apply decal no. **32** on left side of hood.

TEMPLATE

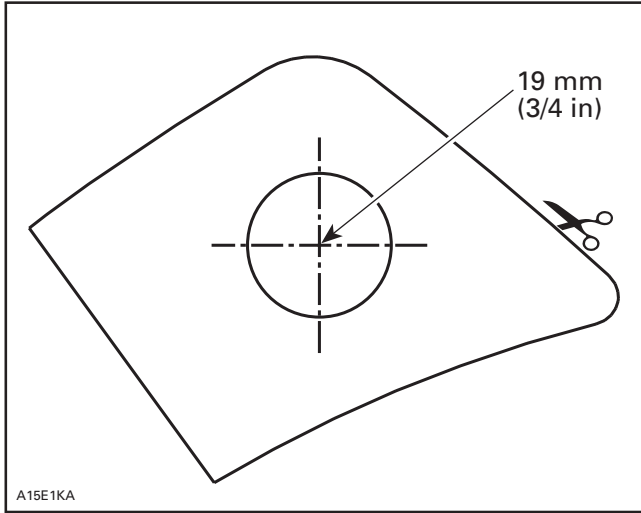

861 504 800

1.	515 175 217	Regulator/Rectifier	Régulateur/redresseur
2.	515 175 142	Starter Support PTO Side	Support de démarreur, côté PDM
3.	207 182 044	Hexagonal Screw M8 x 20 (3)	Vis hexagonale M8 x 20 (3)
4.	234 181 401	Lock Washer M8 (6)	Rondelle-frein M8 (6)
5.	207 182 544	Hexagonal Screw M8 x 25 (2)	Vis hexagonale M8 x 25 (2)
6.	515 175 141	Starter	Démarreur
7.	515 175 143	Starter Support MAG side	Support de démarreur, côté MAG
8.	233 251 414	Flanged Elastic Nut M5 (2)	Écrou élastique à épaulement M5 (2)
9.	391 301 700	Flat Washer M6 (2)	Rondelle plate M6 (2)
10.	234 081 410	Flat Washer M8 (2)	Rondelle plate M8 (2)
11.	207 762 044	Carriage Bolt M6 x 20	Boulon de carrosserie M6 x 20
12.	417 300 057	Ring Gear	Couronne de lancement
13.	236 281 684	Self-Tapping Screw M8 x 16 (6)	Vis autotaraudeuse M8 x 16 (6)
14.	515 175 483	BLACK Negative Ground Cable (2)	Câble de masse négatif NOIR (2)
15.	250 200 000	Star Washer M6 (3)	Rondelle en étoile M6 (3)
16.	233 261 414	Flanged Elastic Nut M6 (2)	Écrou élastique à épaulement M6 (2)
17.	515 175 482	RED Positive Battery Cable	Câble positif de batterie ROUGE
18.	570 151 000	Protector Cap (2)	Capuchon de protection (2)
19.	232 081 414	Hexagonal Nut M8	Écrou hexagonal M8
20.	515 175 489	Fuse Holder	Porte-fusibles
21.	410 111 300	Switch	Interrupteur
22.	394 103 300	Star Washer	Rondelle en étoile
23.	410 112 100	Face Nut	Écrou
24.	570 013 700	Switch Protector (not illustrated)	Cache d'interrupteur (non illustrée)
25.	515 175 243	Battery Seat	Support de batterie
26.	515 175 363	Deflector	Défecteur
27.	410 301 200	Battery	Batterie
28.	515 175 475	Battery Strap	Courroie de batterie
29.	207 151 644	Hexagonal Screw M5 x 16 (2)	Vis hexagonale M5 x 16 (2)
30.	233 251 414	Elastic Stop Nut M5 (2)	Écrou d'arrêt élastique M5 (2)
31.	233 601 416	Hexagonal Nut M10 (2)	Écrou hexagonal M10 (2)
32.	418 001 300	Decal	Autocollant
33.	414 115 200	Locking Tie (8)	Attache (8)
34.	409 901 700	Tubing (3 ft)	Tube (3 pi)
35.	515 175 490	Fuse-Ground Harness	Faisceau de fils fusible/masse
36.	207 161 644	Hexagonal Screw M6 x 16	Vis hexagonale M6 x 16
37.	515 175 541	Switch Harness	Faisceau de fils d'interrupteur