



**LUGGAGE RACK
(P/N 861 776 400)**

⚠ WARNING

For safety reasons, this kit must be installed by an authorized Ski-Doo® snowmobile dealer. Should removal of a locking device (e.g. lock tabs, self-locking fasteners, etc.) be required when undergoing disassembly/assembly, always replace with a new one. This instruction sheet should be given to the purchaser. This kit is designed for specific applicable models only. It is not recommended for units other than those for which it was sold.

NOTE: Installation time is approximately 1.0 hour.

PARTS TO BE INSTALLED

CAUTION: When Bombardier optional rack kit is installed, the maximum carrying capacity is 13 kg (30 lb).

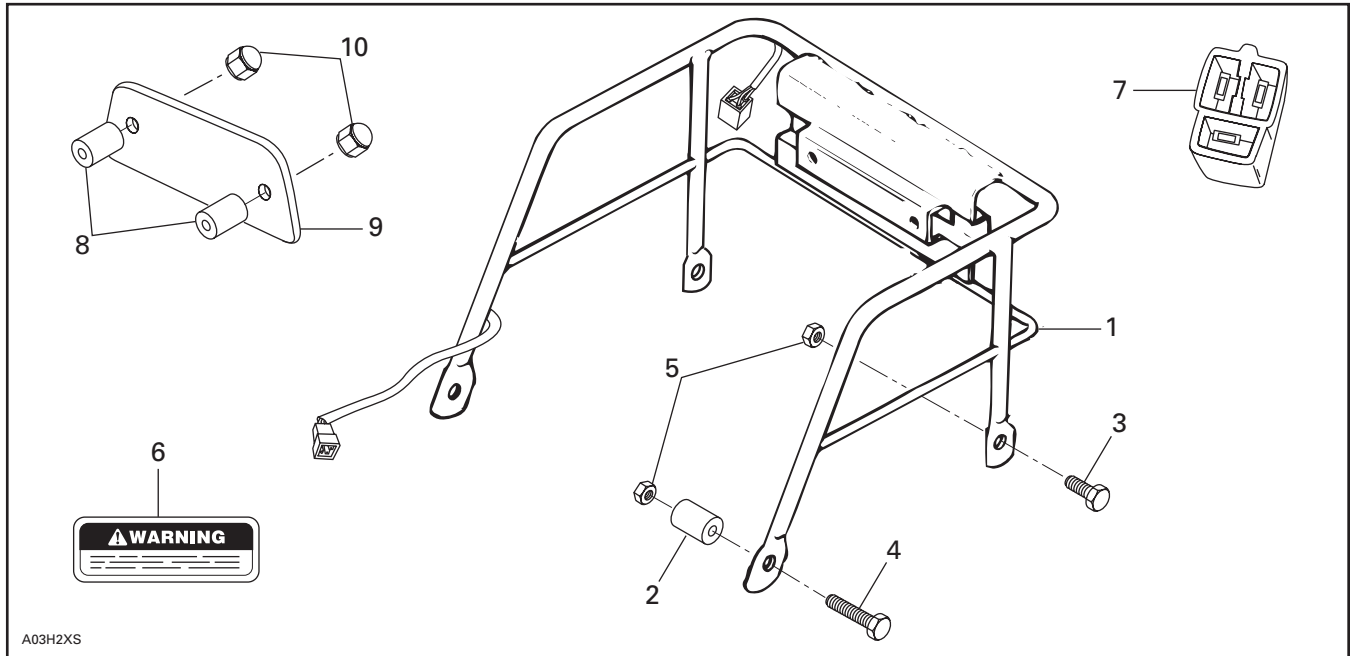

- | | |
|----------------------------|-----------------------------|
| 1. Luggage Rack Ass'y | 6. Warning Decal |
| 2. Spacer (2) | 7. Female Housing |
| 3. Hexagonal Screw (2) | 8. Spacer (2) |
| 4. Hexagonal Screw (2) | 9. Cover |
| 5. Flanged Elastic Nut (4) | 10. Hexagonal Domed Nut (2) |

VEHICLE PREPARATION

Remove the taillight assembly from the seat.

Remove seat.

Remove rear and side moldings.

Remove the tab connectors from the taillight connector housing.

INSTALLATION

Position rack **no. 1** on frame using pre-drilled holes, then secure rear of rack with bolts **no. 3** and flanged elastic nuts **no. 5**. Do not tighten yet.

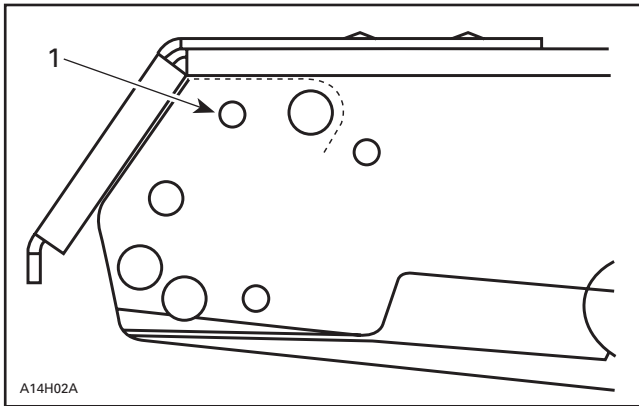

1. Position rack here

Make sure the rack is level then drill 6.5 mm (13/64 in) holes through tunnel using existing holes in rack tubing as a template.

NOTE: If vehicle is equipped with a non-adjustable backrest, remove the bolts on each side but do not discard. Drill holes through backrest support. Only reinstall bolts after having installed the seat. Do not reinstall seat yet.

Remove staples from right rear corner of seat using care.

Drill a 25 mm (1 in) hole as illustrated.

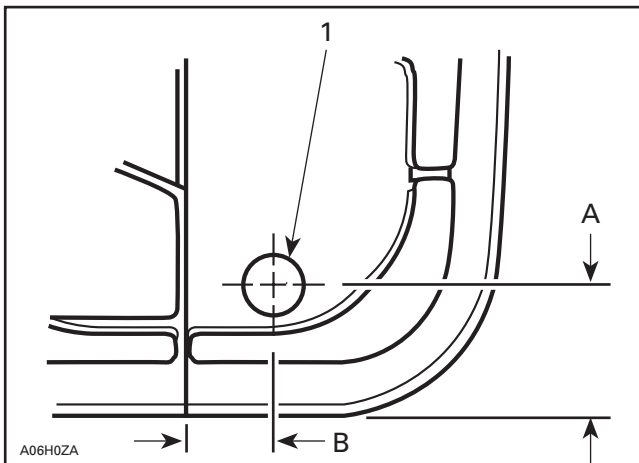

1. Drill hole here
A. 50 mm (2 in)
B. 30 mm (1-3/16 in)

Reroute the wires that were previously removed to the newly drilled hole, underneath the seat.

Install the tab connectors as illustrated into new housing **no. 7**.

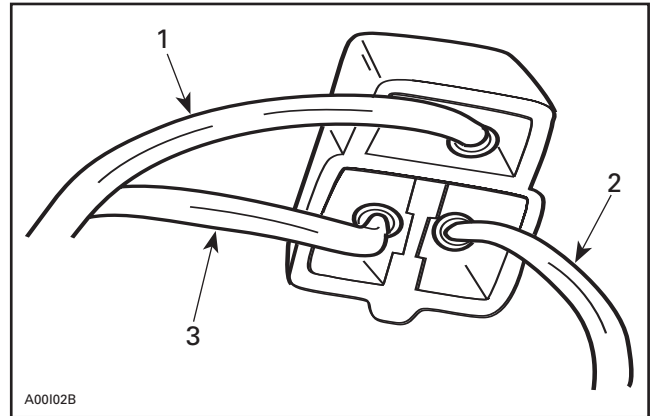

1. YELLOW/BLACK
2. YELLOW
3. WHITE

REINSTALLATION

Restaple seat.

Plug the 2 connectors beneath the seat, then place them in the seat by passing them through the previously drilled hole. Assure to leave some slack in the wires.

Reinstall seat then bolt front part of rack with bolts **no. 4**, spacers **no. 2** and flanged elastic nuts **no. 5**.

Cut rear and side moldings to fit around tubes.

Test taillight and stop light for proper operation.

Install spacers **no. 8** between light ass'y and cover **no. 9** using if necessary washers (not supplied).

Install dome nuts **no. 10**.

Install warning decal **no. 6** on rack.

861 776 400

1.	511 000 038	Luggage Rack Ass'y	Porte-bagages (complet)
2.	517 185 600	Spacer (2)	Entretoise (2)
3.	207 162 044	Hexagonal Screw (2)	Vis hexagonale (2)
4.	207 064 044	Hexagonal Screw (2)	Vis hexagonale (2)
5.	233 261 414	Flanged Elastic Nut (4)	Écrou d'arrêt élastique à épaulement (4)
6.	414 905 200	Warning Decal	Étiquette d'avertissement
7.	409 204 300	Female Housing	Logement de raccord femelle
8.	517 223 600	Spacer (2)	Entretoise (2)
9.	414 976 500	Cover	Couvercle
10.	232 351 423	Hexagonal Domed Nut (2)	Écrou-capuchon hexagonal (2)