

WIRING DIAGRAMS

MODELS	WIRING DIAGRAM PAGE	HEADLIGHT (watt)	TAILLIGHT (watt)	ELECTRICAL SYSTEM OUTPUT (watt)
Formula III 800 Mach Z	Annex 1	60/55 hal.	8/27	290
Formula III 700 R Mach 1R/Z R	Annex 2	60/55 hal.	8/27	290
GT 700	Annex 3	60/55 hal.	8/27	360
GT SE	Annex 4	60/55 hal.	8/27	360

hal. = halogen

WIRING DIAGRAM LEGEND

⚠ WARNING

Ensure all terminals are properly crimped on the wires and all connector housings are properly fastened.

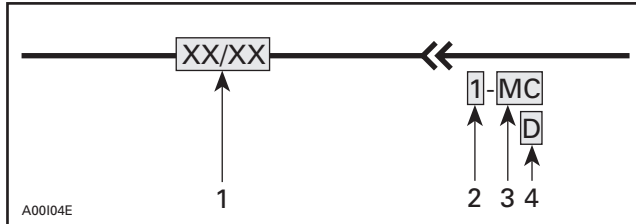

1. Wire colors
2. Connector housing area
3. Housing number per area
4. Wire connector location in housing

WIRE COLORS

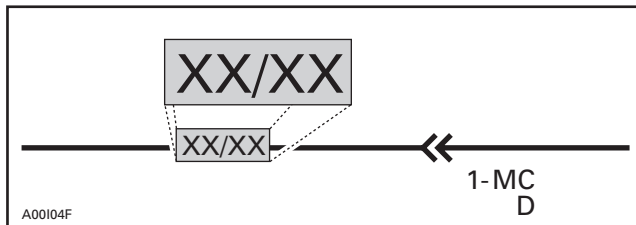

The first color of a wire is the main color, second color is the stripe.

Example: YL/BK is a YELLOW wire with a BLACK stripe.

COLOR CODE					
BE	-	BEIGE	OR	-	ORANGE
BK	-	BLACK	RD	-	RED
BL	-	BLUE	VI	-	VIOLET
BR	-	BROWN	WH	-	WHITE
GN	-	GREEN	YL	-	YELLOW
GY	-	GREY			

CONNECTOR HOUSING AREA

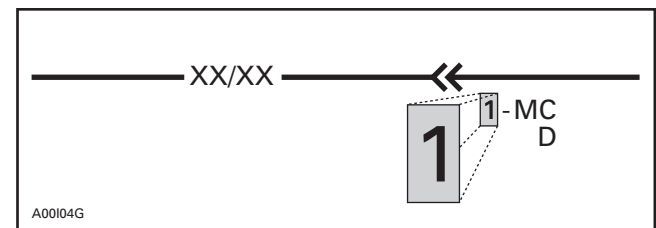

Section 11 WIRING DIAGRAMS
 Subsection 01 (WIRING DIAGRAMS)

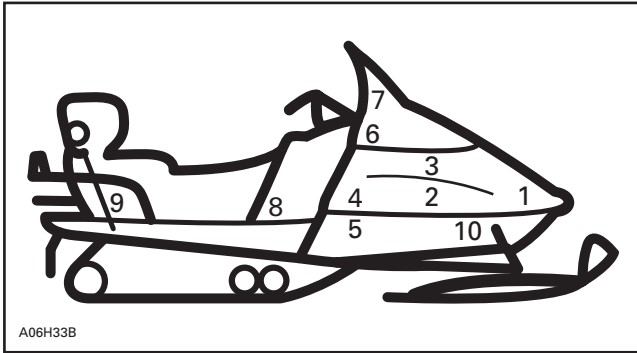

A06H33B

AREA	LOCATION
1	Front of engine compartment
2	Magneto
3	Carburetors
4	Near of intake silencer
5	Near driven pulley
6	Under console
7	Under hood
8	Near fuel tank
9	Rear of seat
10	Under engine

CONNECTOR LOCATION IN HOUSING

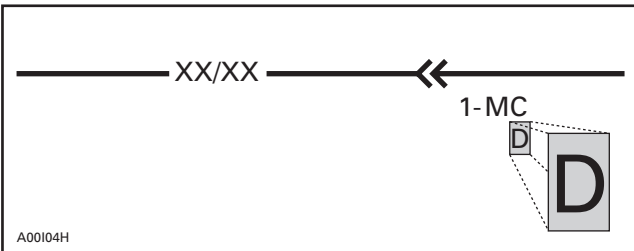

A00104H



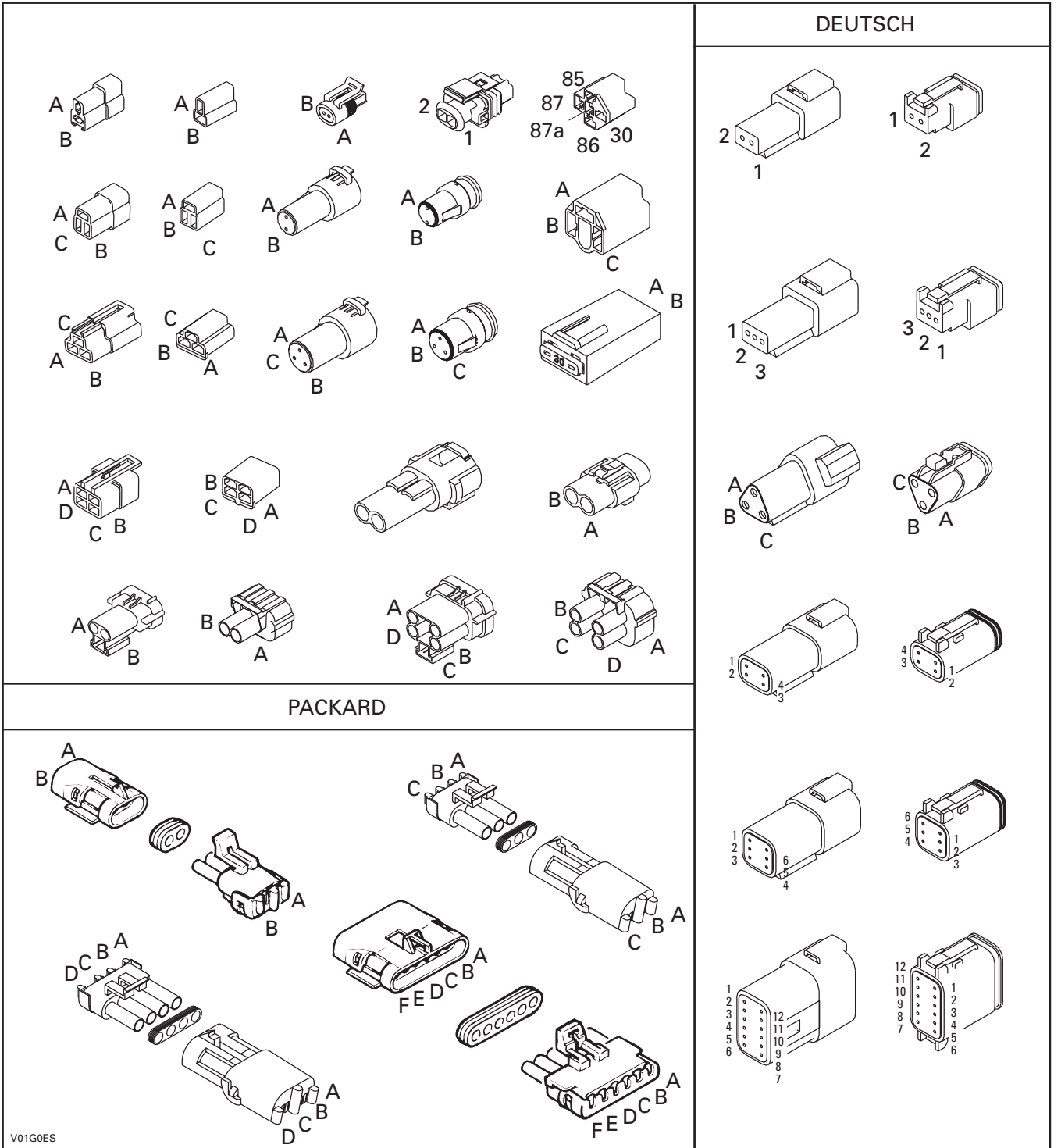







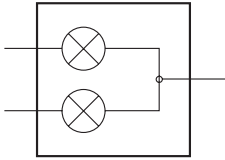

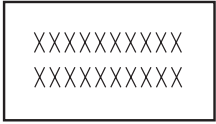
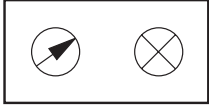

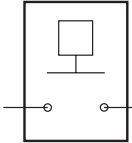
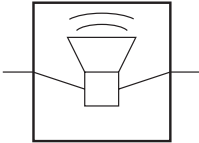
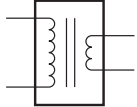
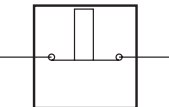
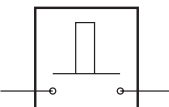

Section 11 WIRING DIAGRAMS
 Subsection 01 (WIRING DIAGRAMS)

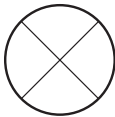
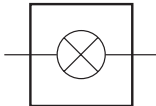
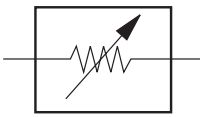
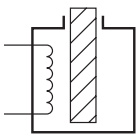

V01G0ES

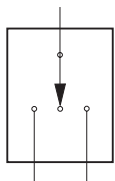
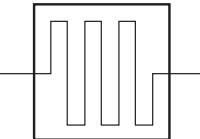
Section 11 WIRING DIAGRAMS
 Subsection 01 (WIRING DIAGRAMS)

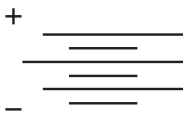
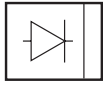
SYMBOLS DESCRIPTION

<p>Beam and tail light</p> 	<p>Female terminal</p> 	<p>Male terminal</p> 	<p>Electronic module</p> 
<p>Meter</p> 	<p>Electric motor</p> 	<p>Low level sensor</p> 	<p>Buzzer</p> 
<p>Ignition coil</p> 	<p>Normally close switch</p> 	<p>Normally open switch</p> 	<p>Male terminal on instrument</p> 
<p>Engine ground</p> 	<p>Frame ground</p> 	<p>Spark plug</p> 	<p>Meter movement</p> 
<p>Bulb</p> 	<p>Pilot</p> 	<p>Analog sensor</p> 	<p>Solenoid valve</p> 
<p>Magneto (Delta)</p> 	<p>3 position switch</p> 	<p>Heating element</p> 	<p>Fuse</p> 
<p>Trigger coil</p> 	<p>Battery</p> 	<p>Diode</p> 	<p>Partially illustrated component</p> 

A00E55S

UNPLUGGING CONNECTORS

Always unplug connectors by pulling on housing not on wire.



A06E1PA

TYPICAL

TAB AND RECEPTACLE CONNECTORS REMOVAL

Tab Connector

It is locked in its housing by a spring tab on its side. Removal is done by squeezing this tab.

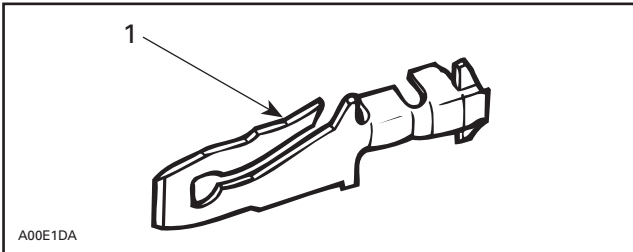

A00E1DA

TAB CONNECTOR

1. Locking tab

To remove:

- Insert a screwdriver or Snap-on TT 600-5 from opposite side of wire and pry locking tab.
- While holding locking tab pried, pull connector toward wire side.

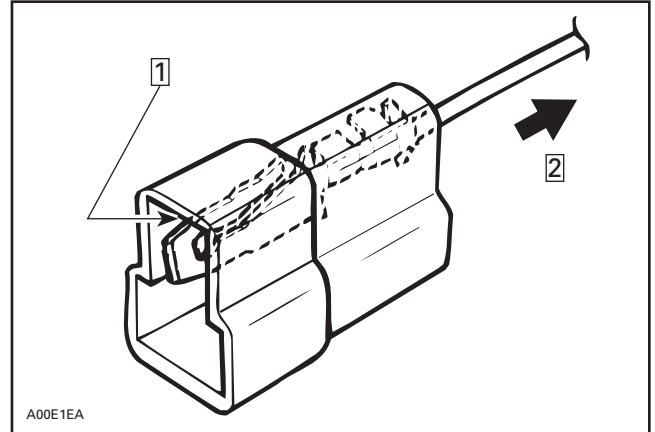

A00E1EA

Step 1: Insert screwdriver here

Step 2: Pull this side

Locking Receptacle Connector

To remove:

- Insert tool Snap-on TT 600-5 in access opening then pull housing toward wire side.

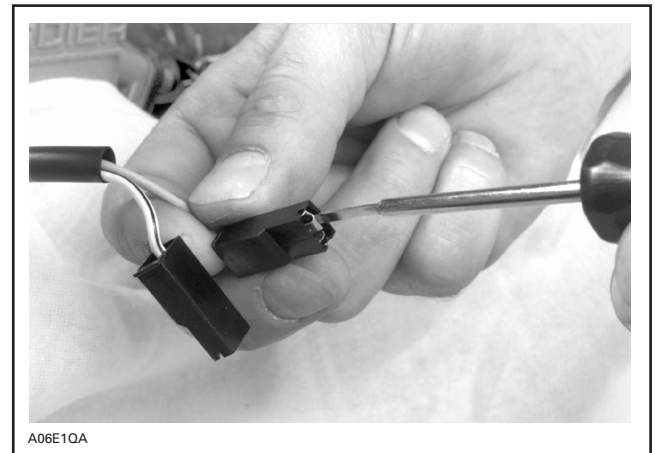

A06E1QA

Section 11 WIRING DIAGRAMS

Subsection 01 (WIRING DIAGRAMS)

Waterproof Connector Housing

Female Connector Housing

To remove:

- Insert tool Snap-on TT 600-5 under lock and twist to lift it.

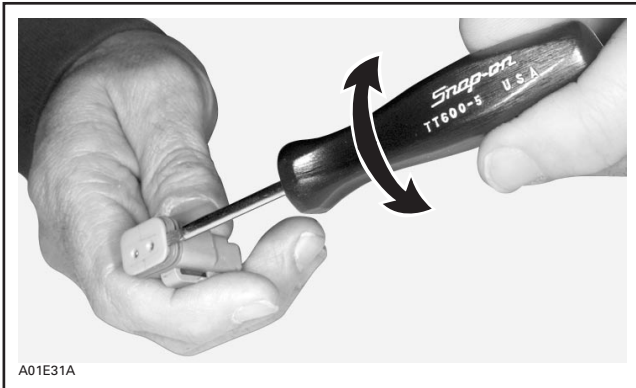

- Pry tab to free connector then pull wire out of housing.

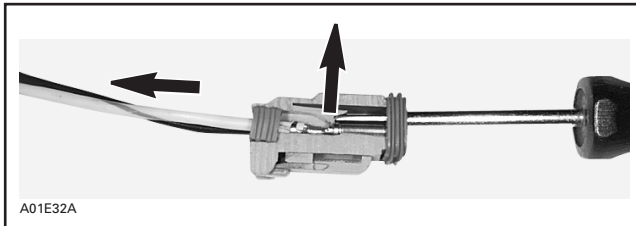

FEMALE CONNECTOR HOUSING — CUT-AWAY

Male Connector Housing

To remove:

- Using a small hook, pull out the lock.

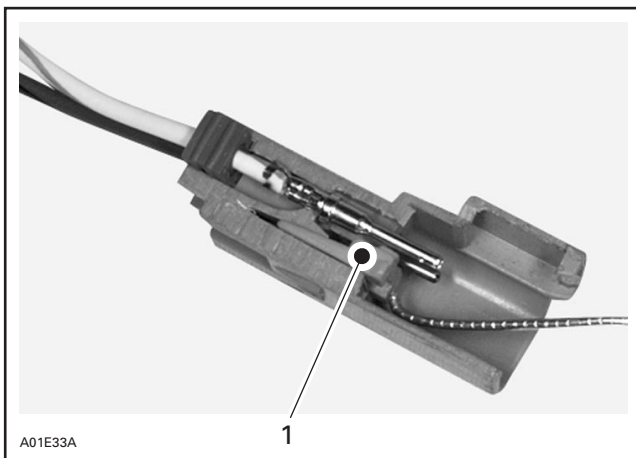

1. Lock

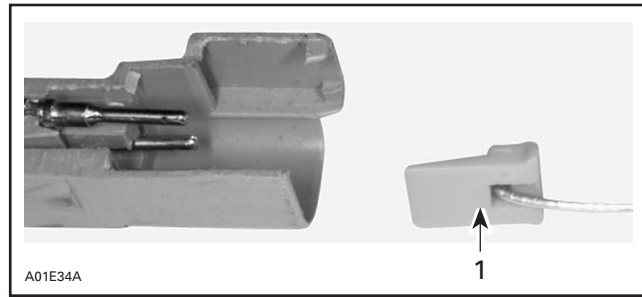

1. Lock

- Pry tab to free connector then pull wire out of housing.

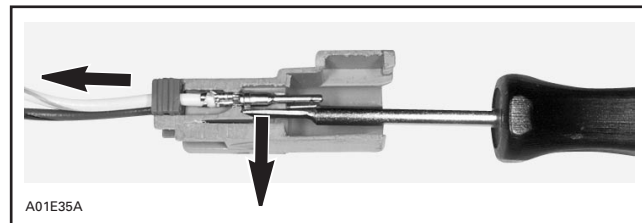

MALE CONNECTOR HOUSING — CUT-AWAY

Round Connector Housing

Female Connector Housing



Male Connector Housing

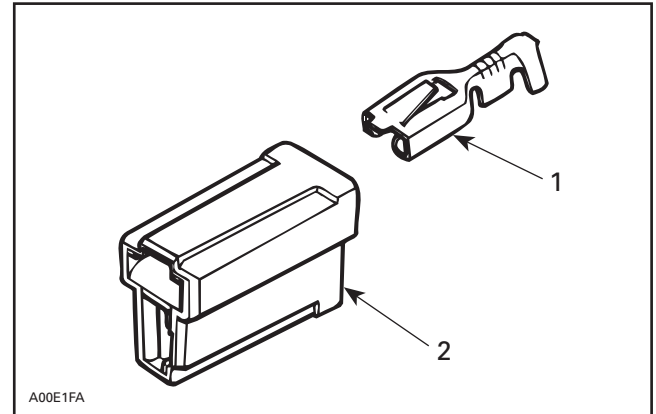
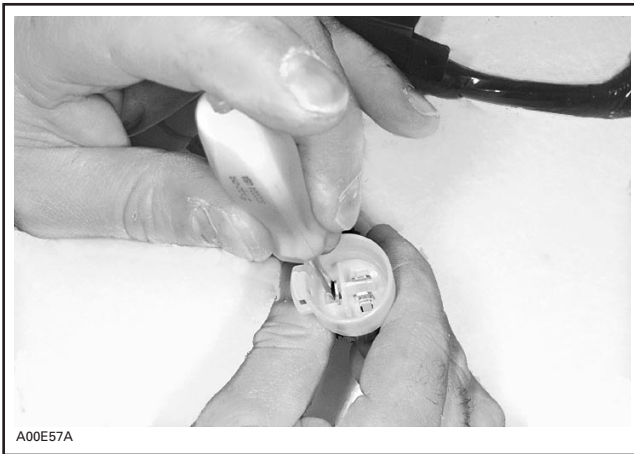

TYPICAL
1. Receptacle
2. Housing

TAB AND RECEPTACLE CONNECTORS INSTALLATION

Prior to installing, make sure locking tab is sufficiently lifted to properly lock.

Insert tab and receptacle connectors in their respective housings as shown in following illustrations. Push sufficiently so that they snap. Try pulling wire to ensure they are properly locked.

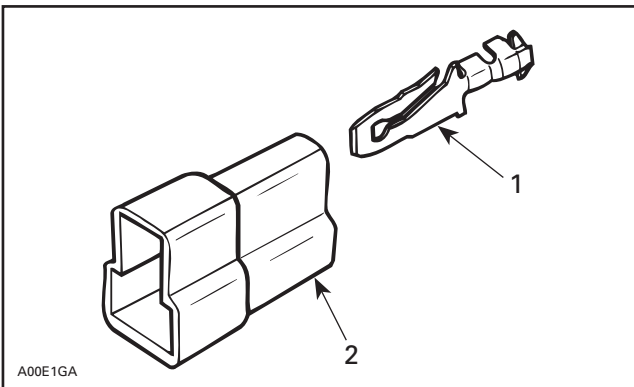

1. Tab
2. Housing

Section 11 WIRING DIAGRAMS

Subsection 01 (WIRING DIAGRAMS)

ACCESSORIES INSTALLATION

On all **electric start models**: The direct current (DC) utilizes the snowmobile frame as ground "wire" while all alternating current (AC) consumers (lights, heated grips, fuel gauge, etc.) utilize a separate ground wire.

Never interconnect AC and DC grounds as an AC voltage drop will result. When installing accessories on **any** snowmobile, connect their wires directly to the YELLOW and YELLOW/BLACK lighting coil wires.

Even if **manual start models** have an AC ground to the chassis (on voltage regulator), all accessories utilize a ground wire isolated from chassis. When an electric starter kit is installed, the voltage regulator and its ground wire are replaced by a voltage rectifier/regulator unit permitting a completely isolated AC circuit.

WARNING

Keep wires away from any rotating, moving, heating, vibrating or sharp edge. Use proper fastening devices as required.

ANNEX 1

**FORMULA III 800
MACH 2**

2000 MACH Z, FORMULA III 800

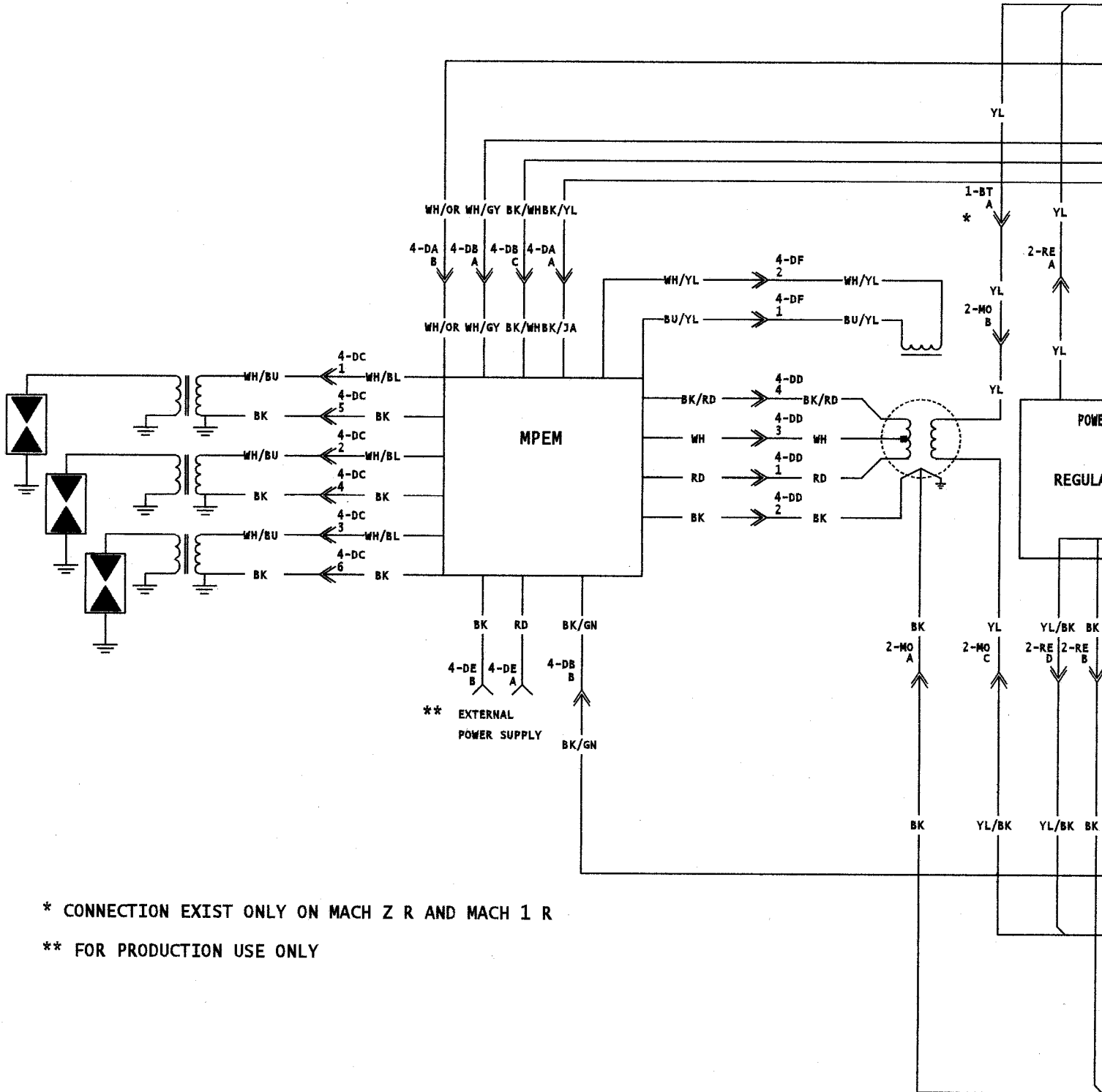

IGNITION SYSTEM

POWER SUPPLY

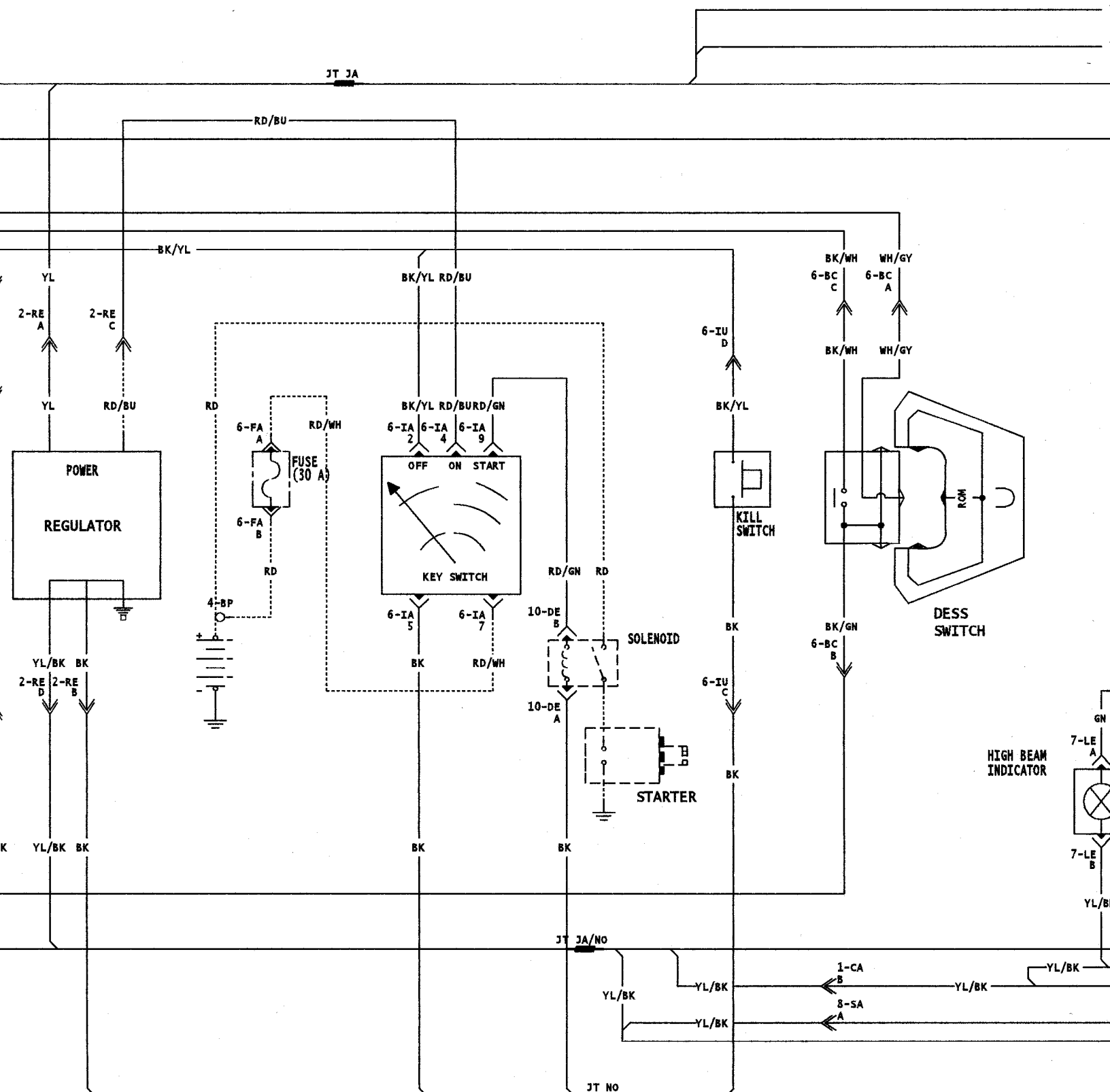

POWER SUPPLY ————— STARTER AND IGNITION SWITCHES —————

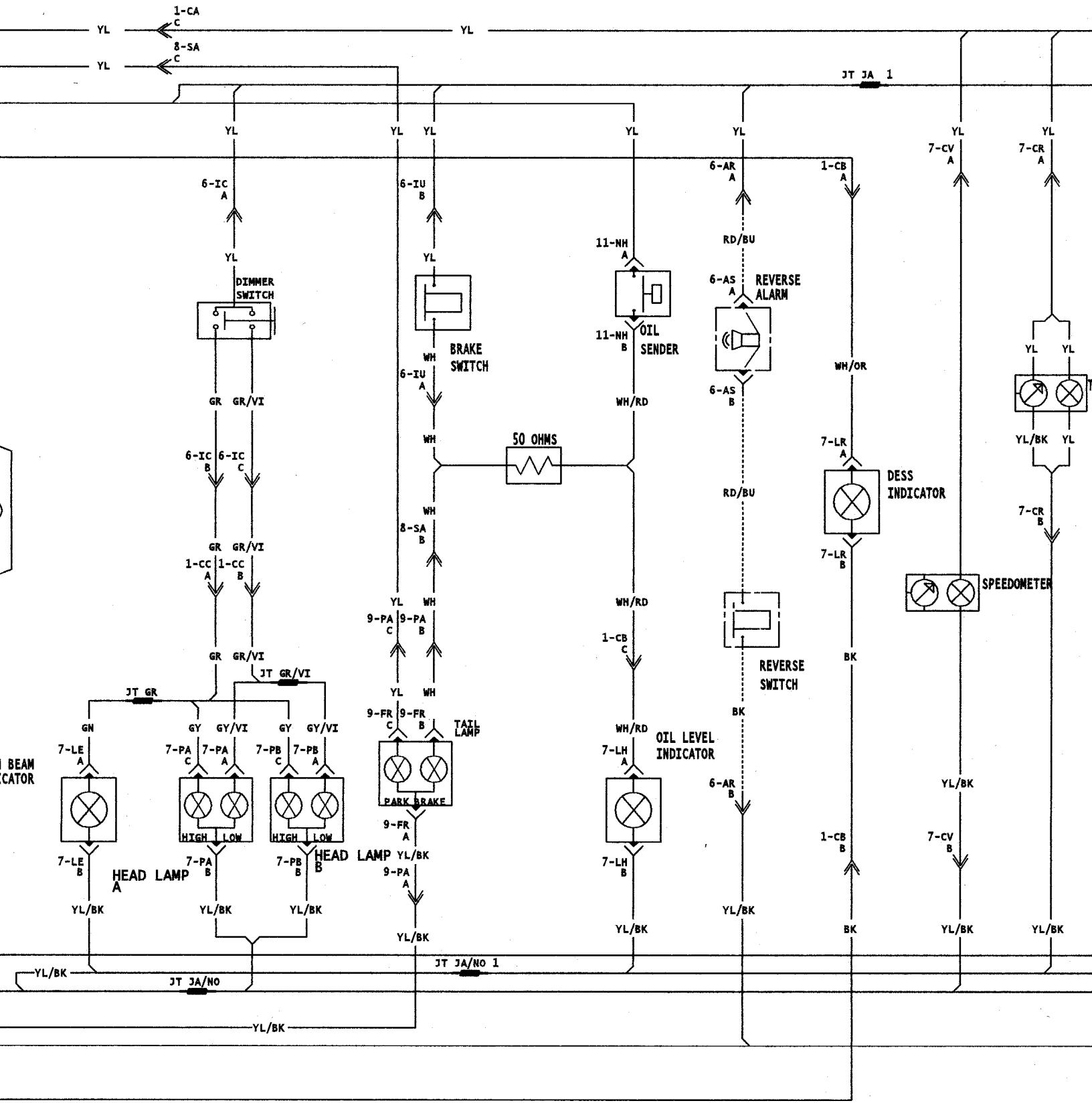

LIGHTING

INSTR

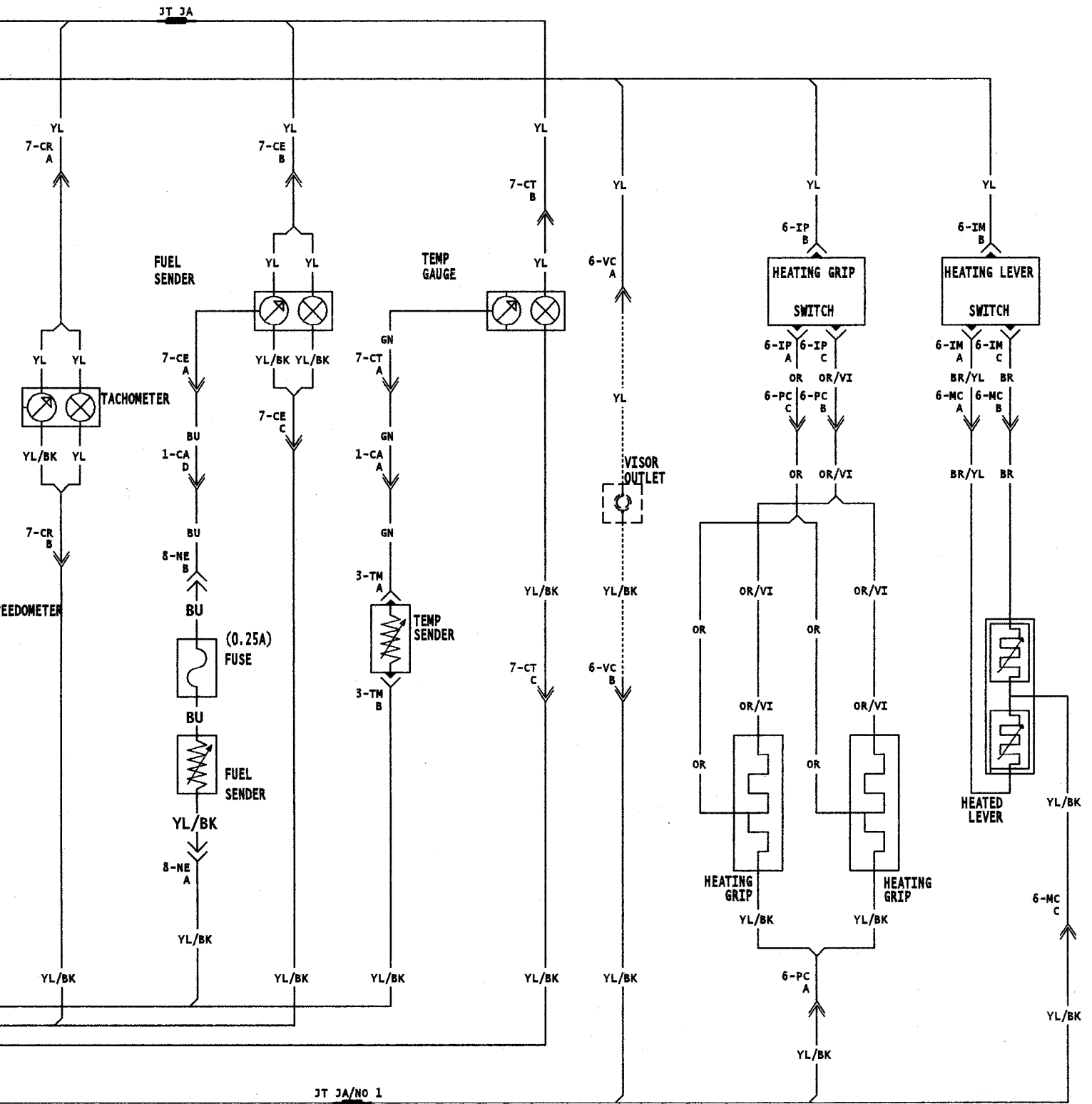

INSTRUMENTS

HEATING ELEMENTS

ANNEX 2

FORMULA III 700 R MACH 1R/Z R

2000 MACH ZR, MACH 1R/FORMULA III 700 R

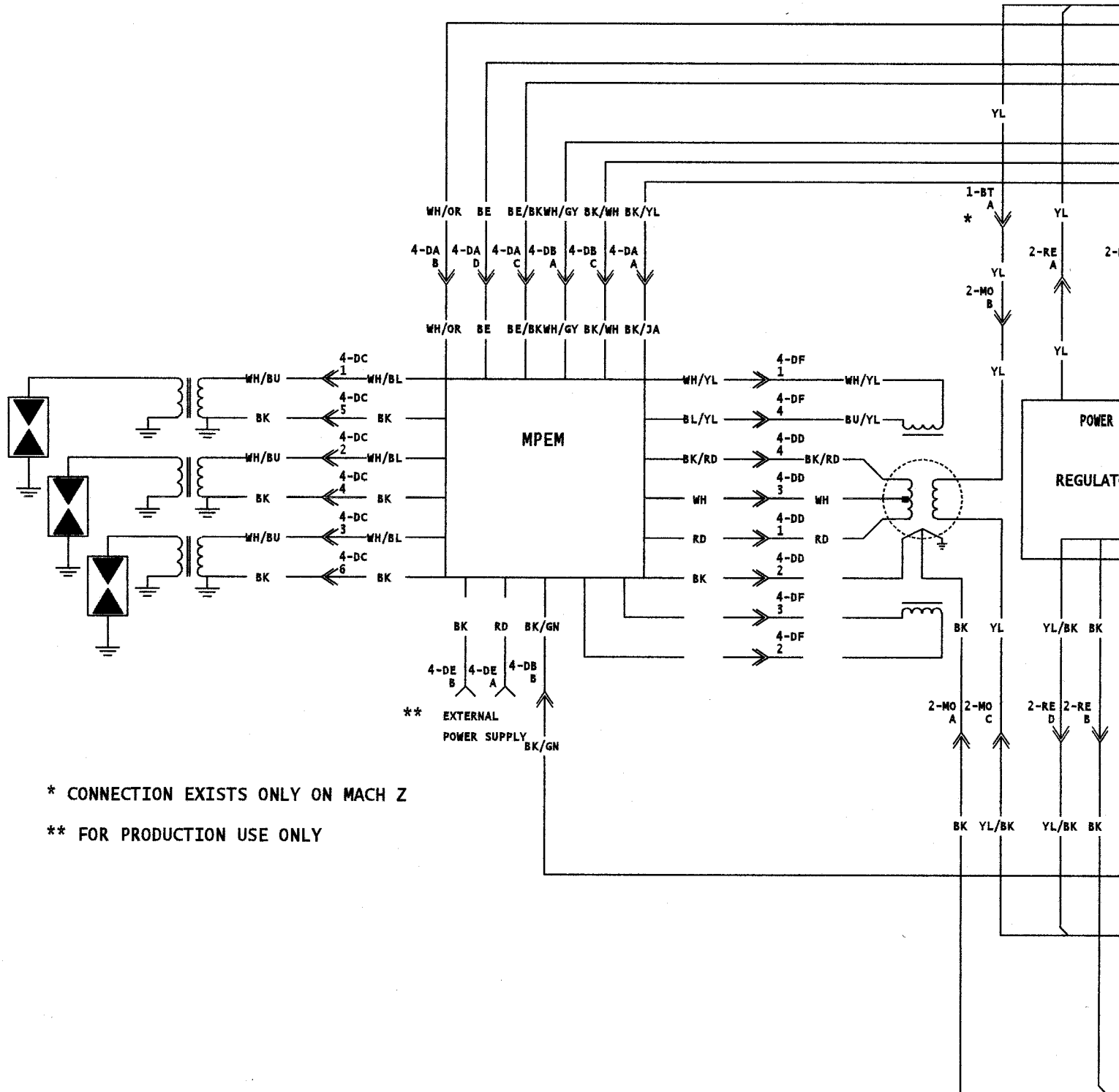

* CONNECTION EXISTS ONLY ON MACH Z

** FOR PRODUCTION USE ONLY

IGNITION SYSTEM

POWER SUPPLY

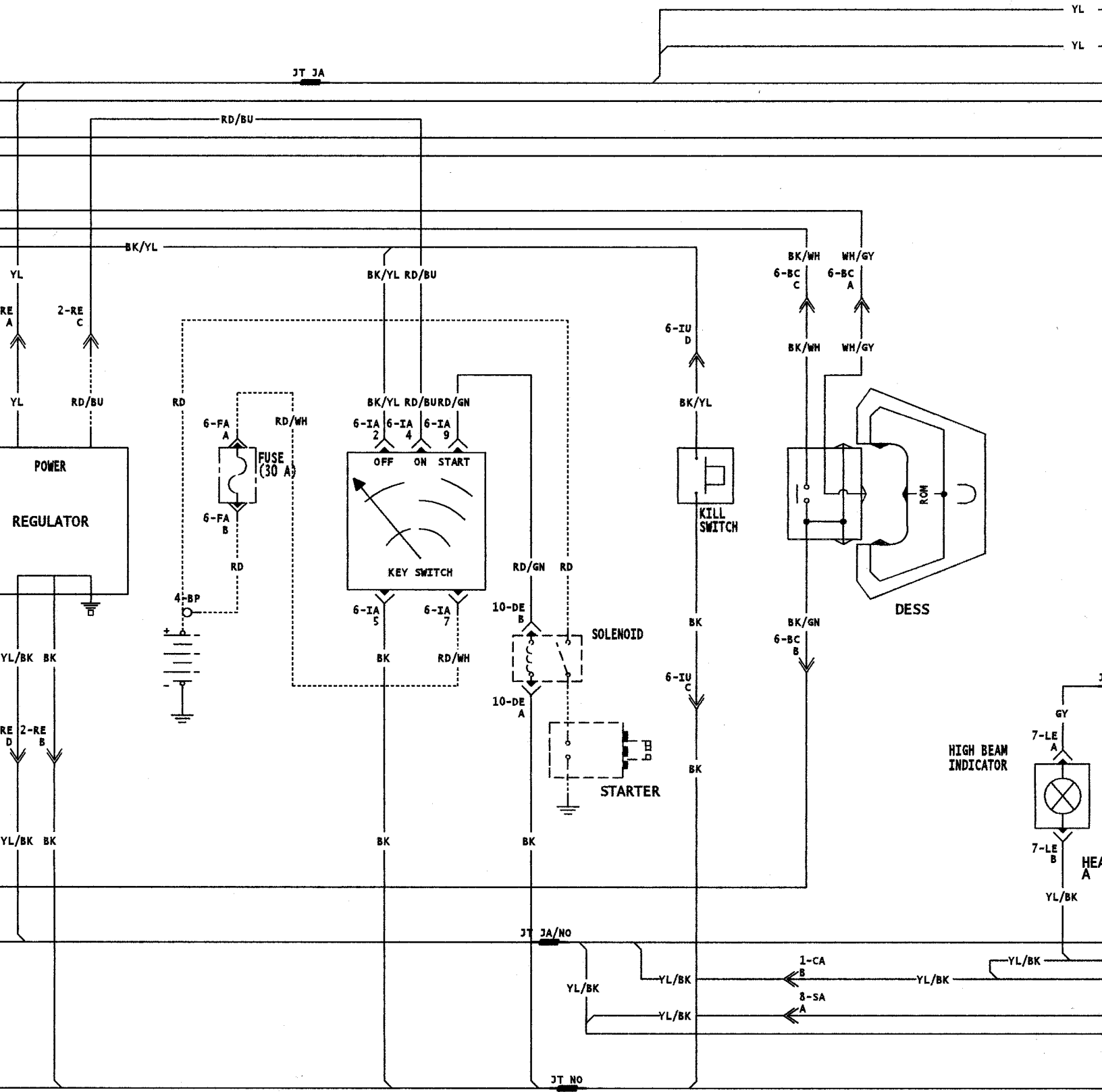

SUPPLY ———— | | ———— STARTER AND IGNITION SWITCHES ———— | | ————

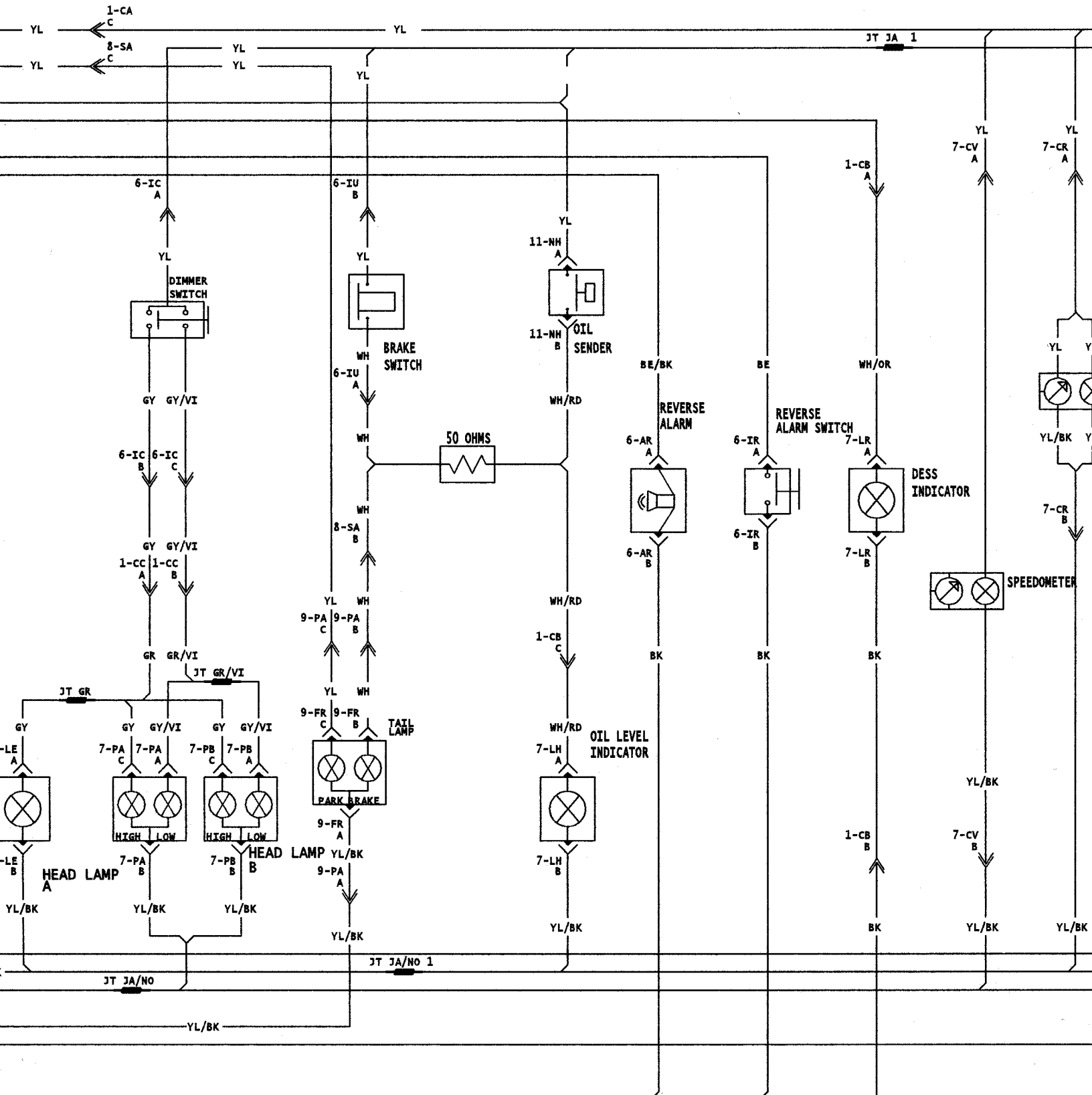

LIGHTING



I

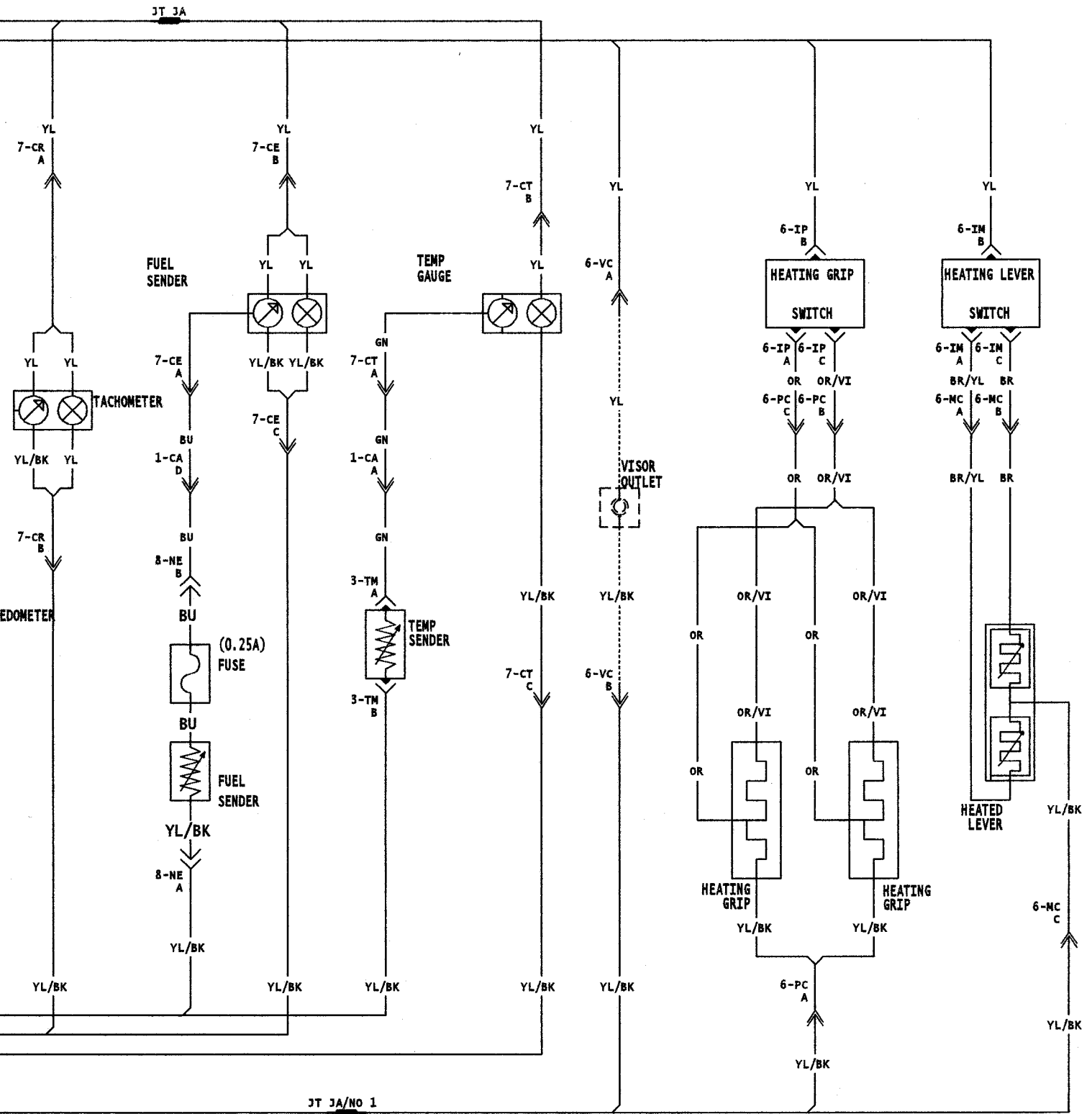

INSTRUMENTS

HEATING ELEMENTS

ANNEX 3

GT 700

2000 GRAND TOURING 700

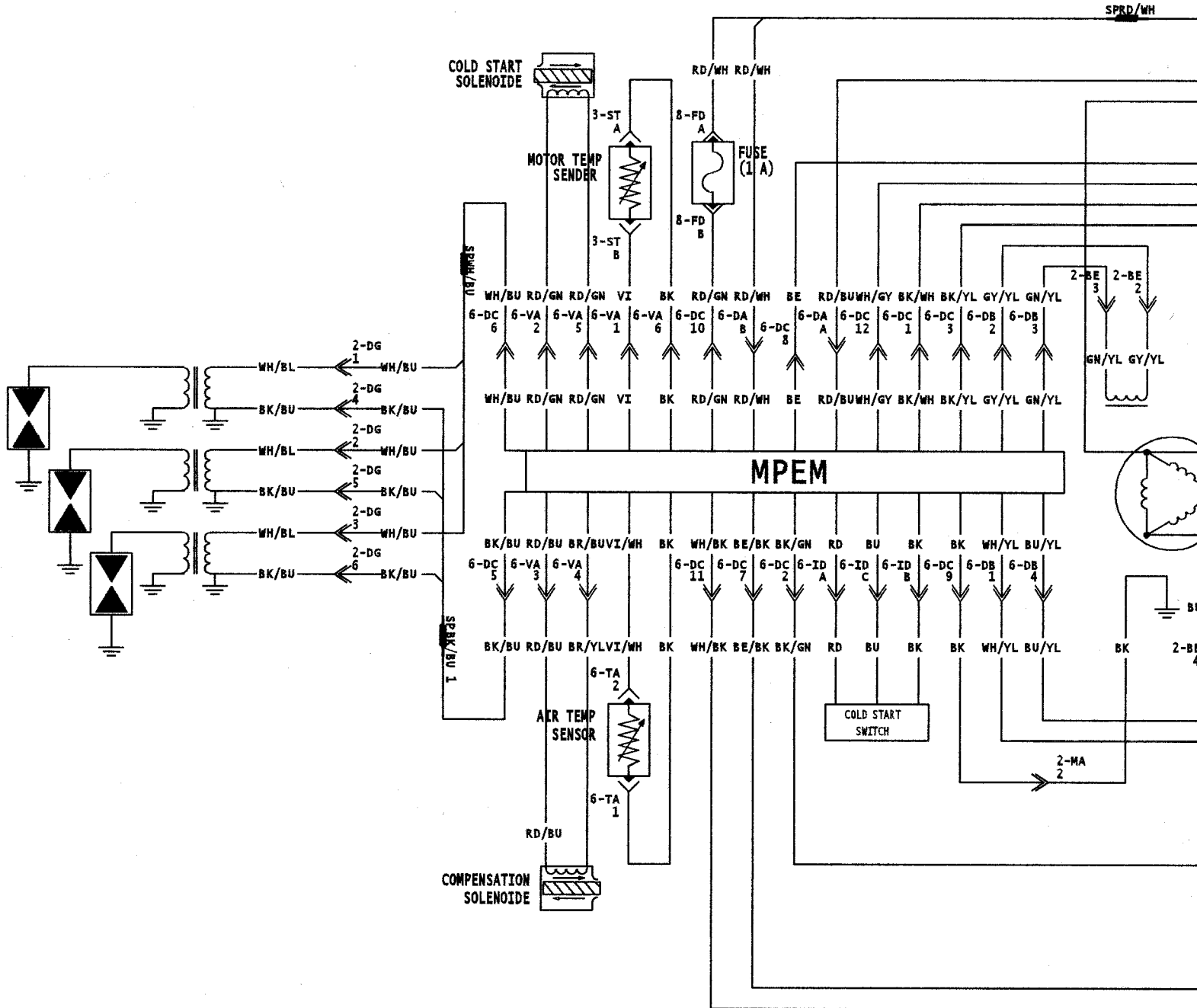

IGNITION SYSTEM

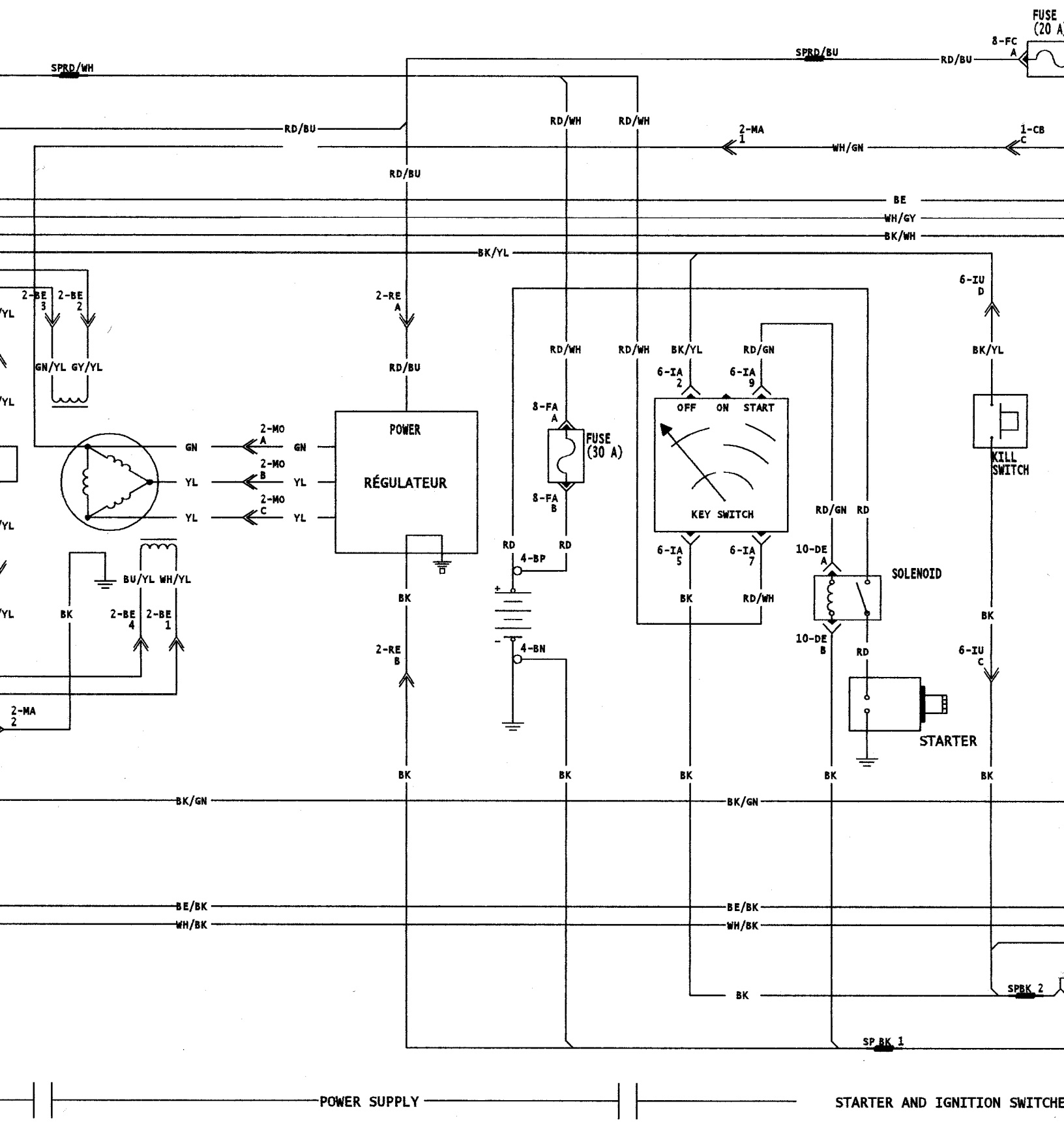

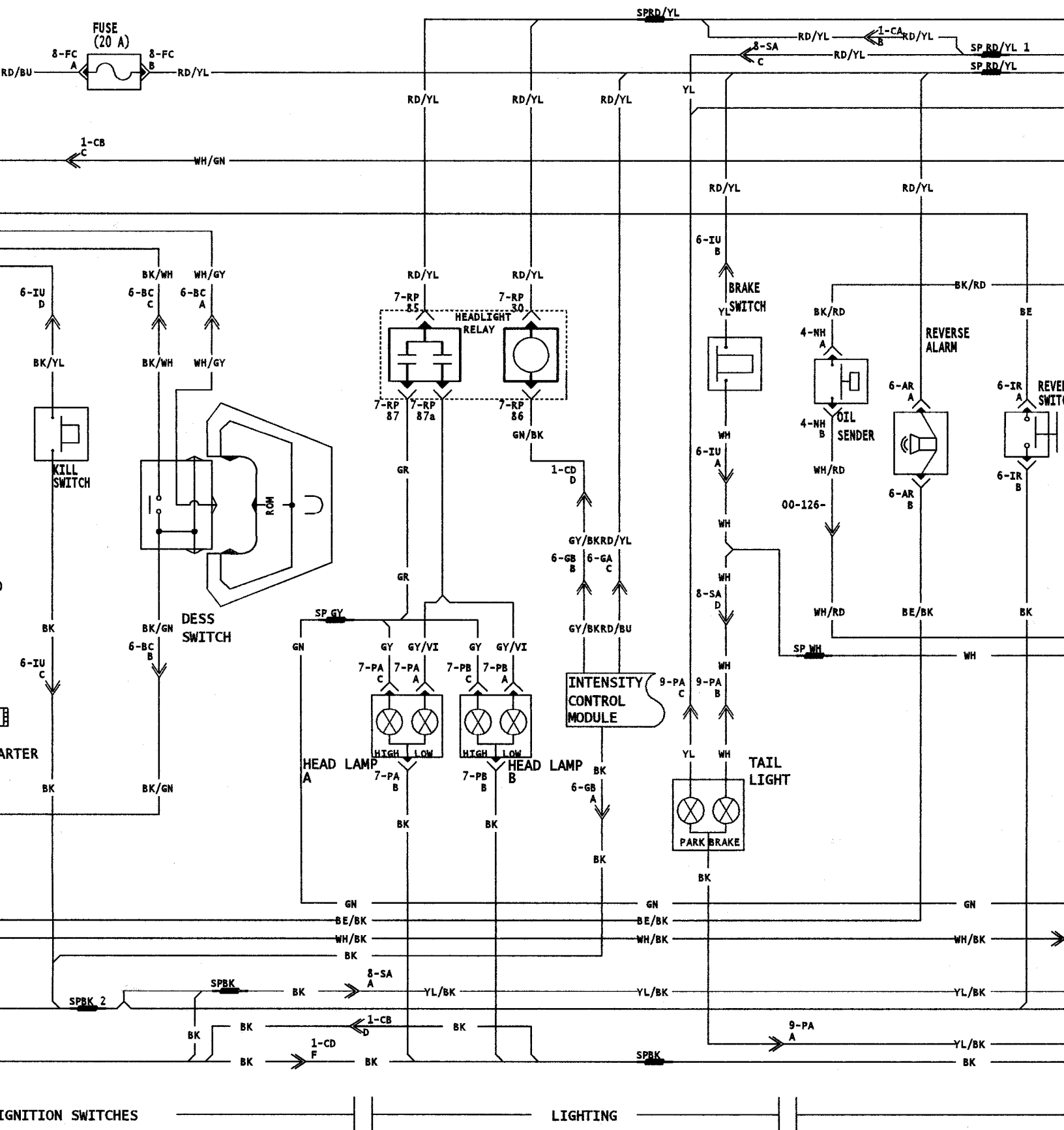

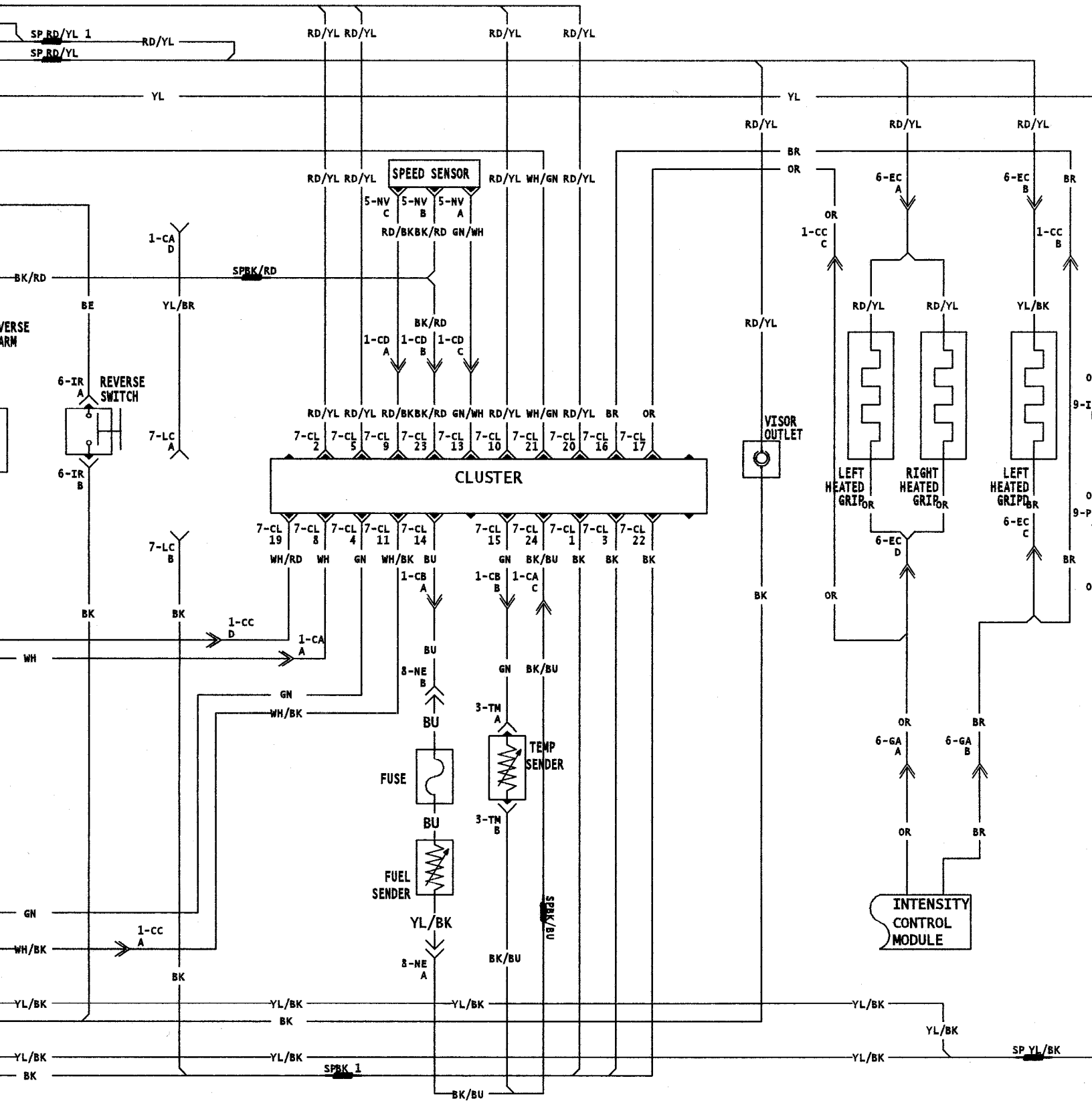

INSTRUMENTS

HEATING ELEMENTS

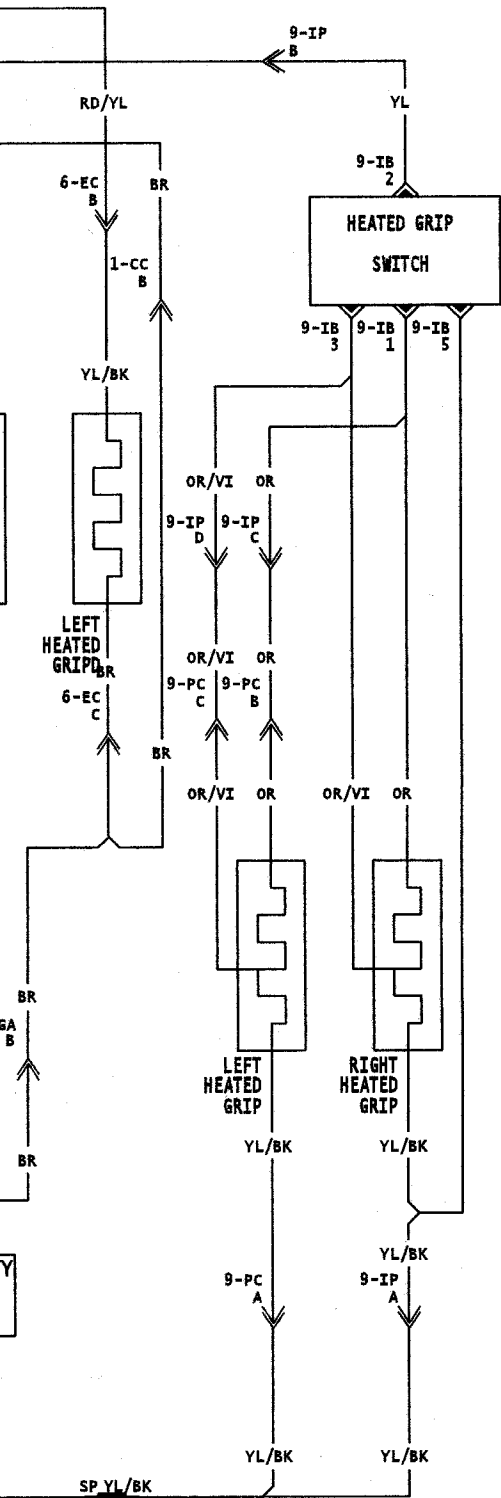

ING ELEMENTS

ANNEX 4

GT SE

2000 GRAND TOURING SE

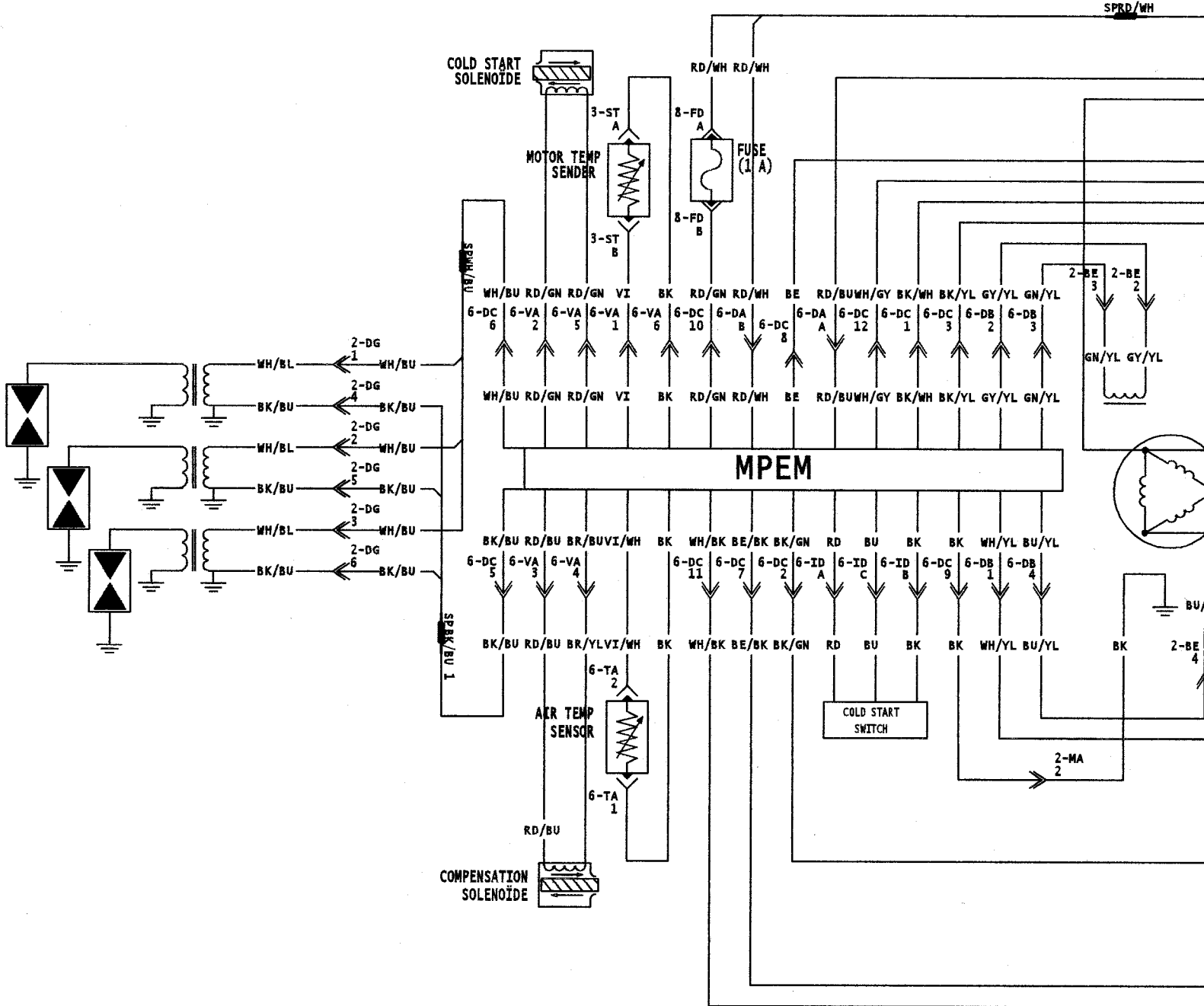

IGNITION SYSTEM

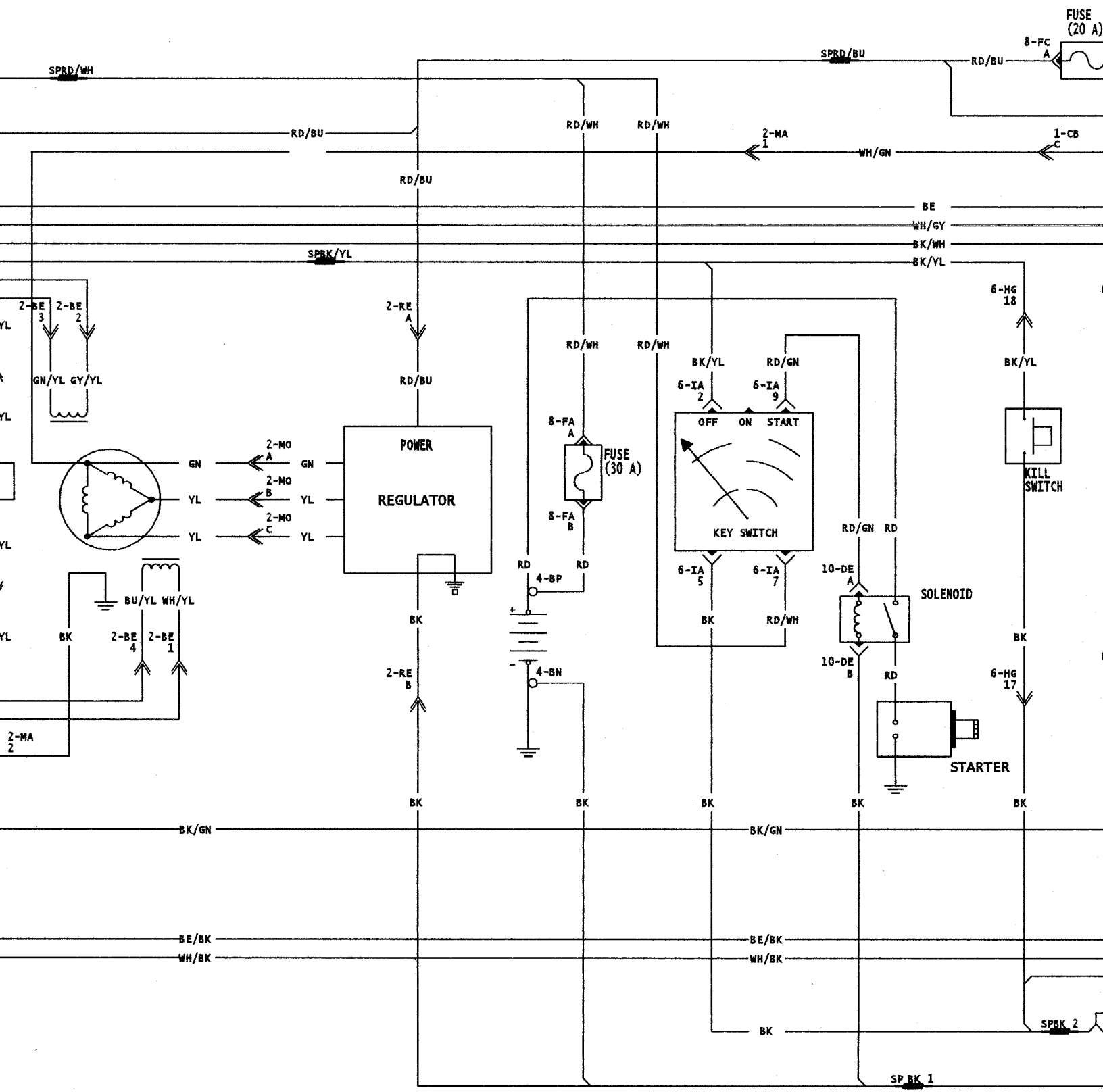

POWER SUPPLY

STARTER AND IGNITION SWITCHES

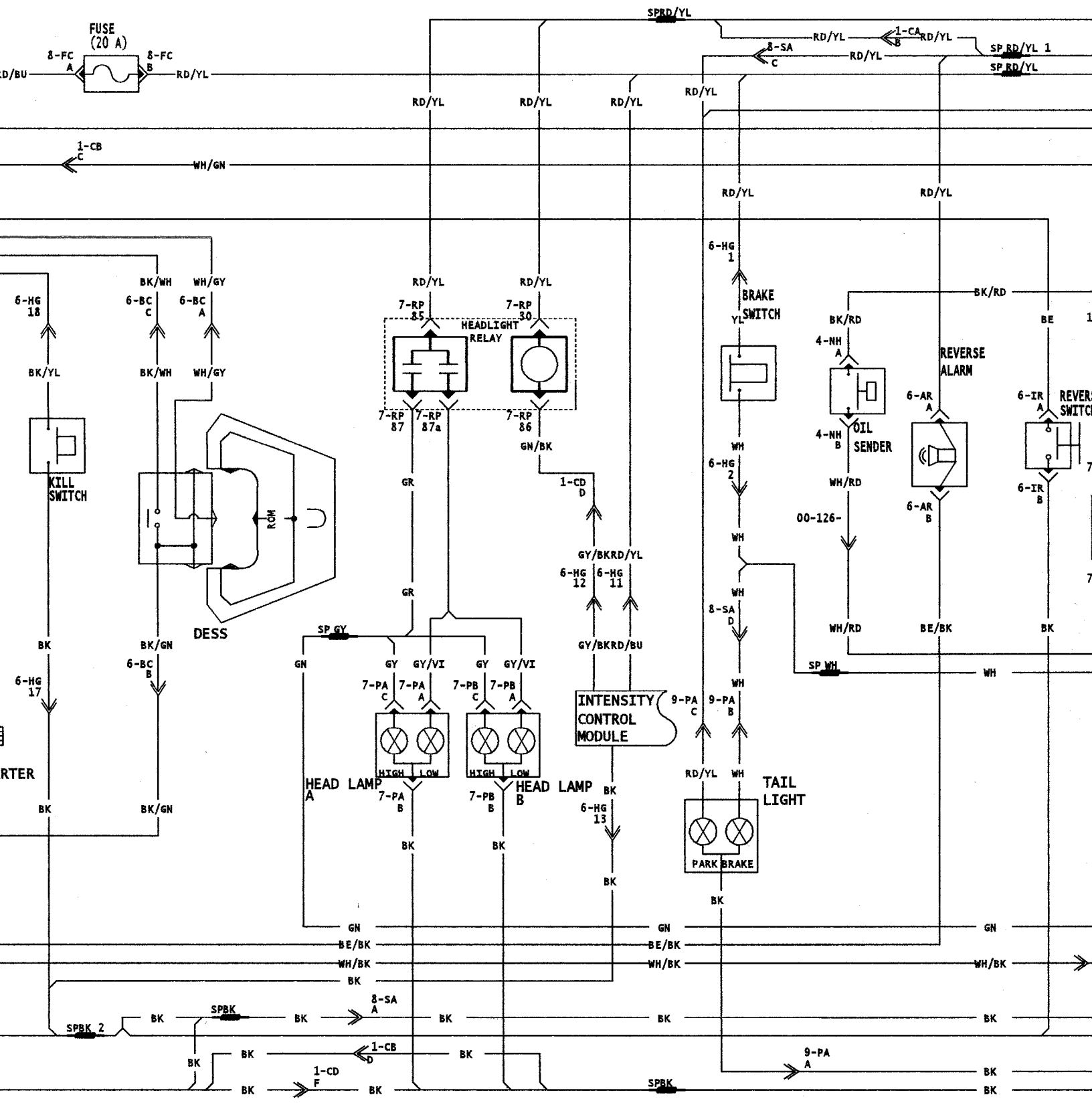

IGNITION SWITCHES

LIGHTING

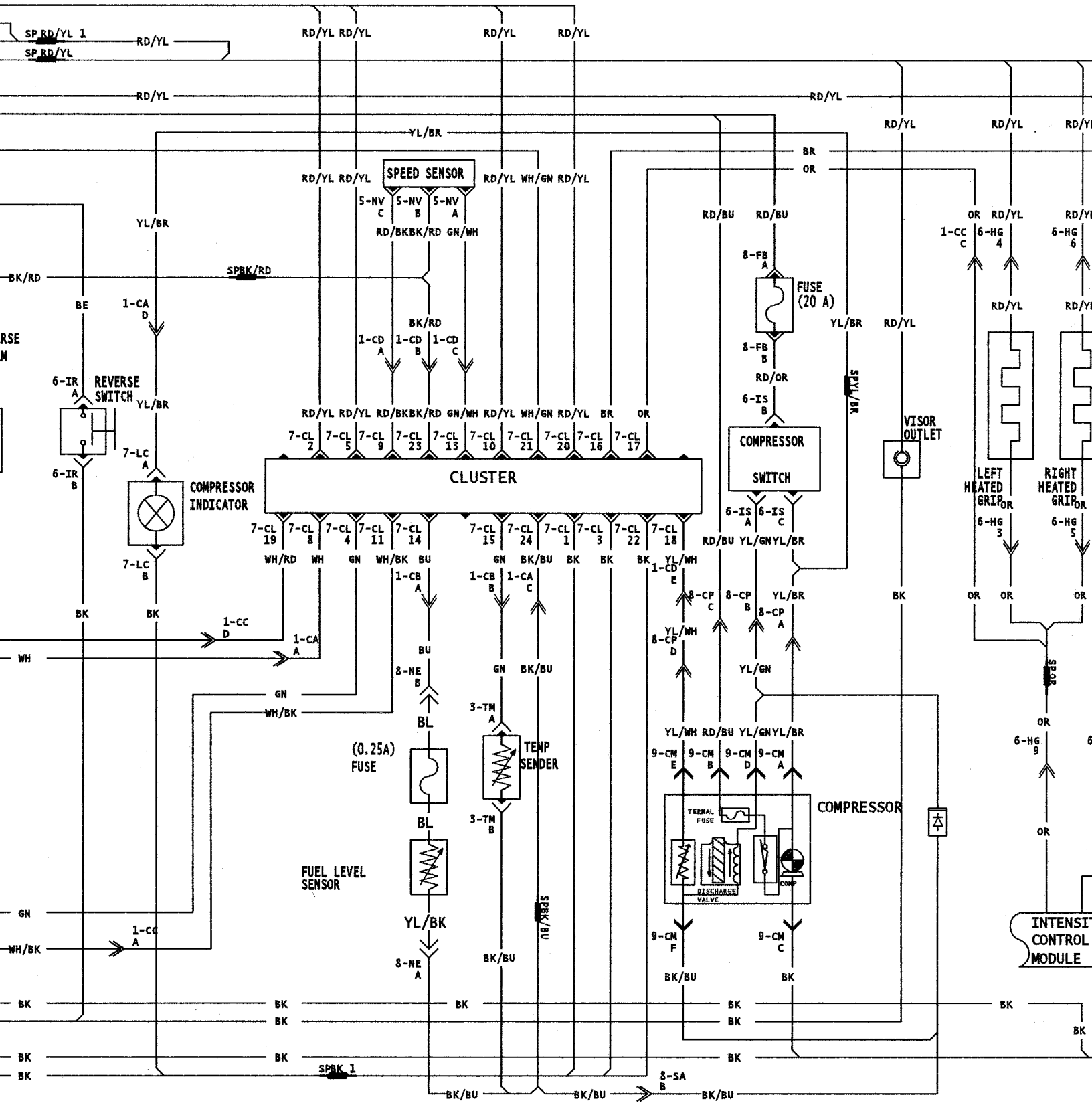

INSTRUMENTS

AIR SUSPENSION CONTROL SYSTEM

HEATING

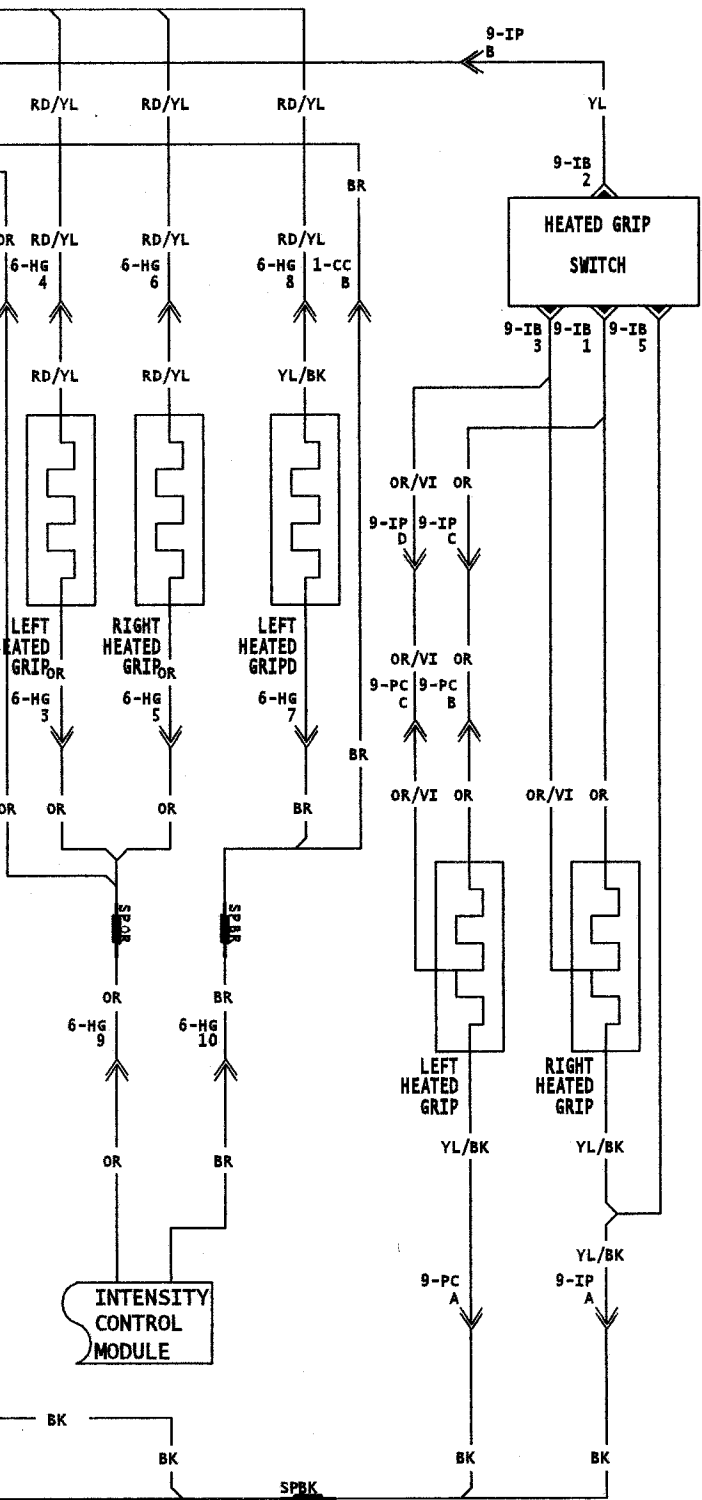

HEATING ELEMENTS



© Trademarks of Bombardier Inc. and/or its subsidiaries.
© 1999 Bombardier Inc. All rights Reserved
Printed in Canada

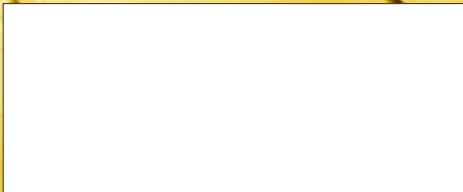

BOMBARDIER
RECREATIONAL PRODUCTS



VERSION FRANÇAISE ÉGALEMENT DISPONIBLE