

TABLE OF CONTENTS

IGNITION TIMING	06-02-1
NIPPONDENSO TRIGGER COIL SYSTEM	06-02-1
SPARK PLUGS	06-03-1
NGK SPARK PLUG	06-03-1
NGK SPARK PLUG NUMBERING SYSTEM	06-03-1
DESIGN SYMBOLS USED IN NGK SPARK PLUGS	06-03-2
DISASSEMBLY.....	06-03-3
HEAT RANGE	06-03-3
FOULING	06-03-3
SPARK PLUG ANALYSIS.....	06-03-3
SPARK PLUG INSTALLATION.....	06-03-4
SPARK PLUG TIGHTENING TORQUE	06-03-4
BATTERY	06-04-1
REMOVAL.....	06-04-1
CLEANING	06-04-1
INSPECTION	06-04-1
HYDROMETER TEST	06-04-2
BATTERY STORAGE.....	06-04-2
ACTIVATION OF NEW BATTERY	06-04-3
SERVICING.....	06-04-5
TIPS FOR CHARGING A USED BATTERY	06-04-5
BATTERY CHARGING EQUIPMENT	06-04-6
INSTALLATION OF BATTERY	06-04-7
ELECTRIC STARTER	06-05-1
REMOVAL.....	06-05-2
INSTALLATION	06-05-2
SOLENOID SWITCH	06-05-2
TESTING PROCEDURE	06-06-1
GENERAL	06-06-1
SYSTEM TESTING	06-06-3
IGNITION SYSTEM TESTING SEQUENCE	06-06-3
LIGHTING SYSTEM TESTING SEQUENCE.....	06-06-3
1 .SPARKING	06-06-3
2. ELECTRICAL CONNECTOR TESTING	06-06-3
3. IGNITION SWITCH, TETHER CORD SWITCH AND EMERGENCY SWITCH TESTING.	06-06-4
4. IGNITION GENERATOR COIL VOLTAGE TESTING.....	06-06-5
5. TRIGGER COIL TESTING	06-06-5
6. MPEM VOLTAGE TESTING	06-06-5

Section 06 ELECTRICAL

Subsection 01 (TABLE OF CONTENTS)

7. HIGH VOLTAGE COIL VOLTAGE TESTING 06-06-6

8. MPEM SUPPLY VOLTAGE TESTING 06-06-6

9. MPEM TESTING 06-06-6

CONCLUSION..... 06-06-6

LIGHTING GENERATOR COIL VOLTAGE TESTING 06-06-6

CONCLUSION..... 06-06-6

ELECTRIC ACCESSORIES TESTING 06-06-7

INSPECTION OF AC CIRCUIT ISOLATION..... 06-06-13

INSPECTION 06-06-13

INSPECTION OF HEATING ELEMENTS 06-06-14

IGNITION TIMING

NIPPONDENSO TRIGGER COIL SYSTEM

Normally ignition timing adjustment should not be required. It has been set at factory and it should remain correctly adjusted since every part is fixed and not adjustable. The only time the ignition timing might have to be changed would be when removing and reinstalling the magneto housing, replacing the crankshaft, the magneto flywheel, the trigger coil or the MPEM. If the ignition timing is found incorrect, first check for proper crankshaft alignment. This might be the indication of a twisted crankshaft.

The ignition timing can be checked with either the engine hot or cold. Also, the ignition timing is to be checked at 3500 RPM with a timing light.

NOTE: Between 3000 and 4000 RPM, the spark advance does not change. So when checking ignition timing at 3500 RPM, a change in engine speed within ± 500 RPM will not affect the timing mark when checked with the timing light.

IMPORTANT: During the first 8 hours the timing curve is retarded by 2° between 4500 RPM and maximum RPM. Because checking ignition timing is done at a lower RPM, this will not affect the 3500 RPM timing specification. There will be no further timing adjustment required before and after these hours.

Scribing a Timing Mark

1. Clean the area around the MAG spark plug, and remove it.
2. Install the TDC gauge in the spark plug hole, (magneto side) and adjust as follows:
 - a. Position the magneto flywheel at approximately TDC.

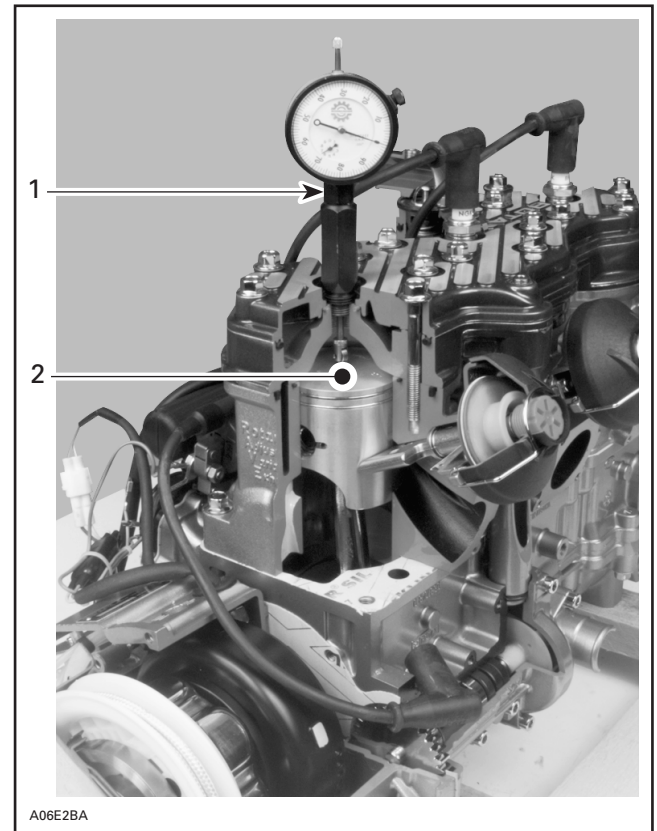

A06E2BA

TYPICAL

1. TDC gauge on MAG side
2. MAG side piston at TDC

- b. Assemble the gauge to the adaptor and tighten the roller lock nut. Do not tighten the adaptor lock nut.
- c. Screw the adaptor into the spark plug hole and tighten to prevent movement in the plug hole.
- d. Position the dial face toward the PTO. Move the gauge down until the needle just begins to move, then move down a further 5 or 6 mm (approximately 1/4 in). Tighten adaptor lock nut by hand.

Section 06 ELECTRICAL

Subsection 02 (IGNITION TIMING)

3. Locate the piston TDC position as follows:
 - a. Slowly rotate the drive pulley back and forth across TDC while observing the needle. Note that the needle stops moving only as the piston is changing direction.
 - b. Rotate the dial face so that "0" is in line with the needle when it stops moving.
 - c. Again, slowly rotate the drive pulley back and forth across TDC and adjust the dial face to "0", until the needle always stops exactly at "0" before changing direction.
 - d. "0" now indicates exact TDC.
4. Rotate the drive pulley clockwise, one-quarter turn then carefully rotate it counterclockwise until the needle indicates the specified measurement, indicated in TECHNICAL DATA 10.
5. Scribe one mark on removable side member upper ridge and one on lower ridge just above drive pulley center line. These both marks will be used as a reference point.
6. With the TDC gauge indicating specified timing, scribe a mark on drive pulley inner half in line with both marks previously scribed on removable side member.

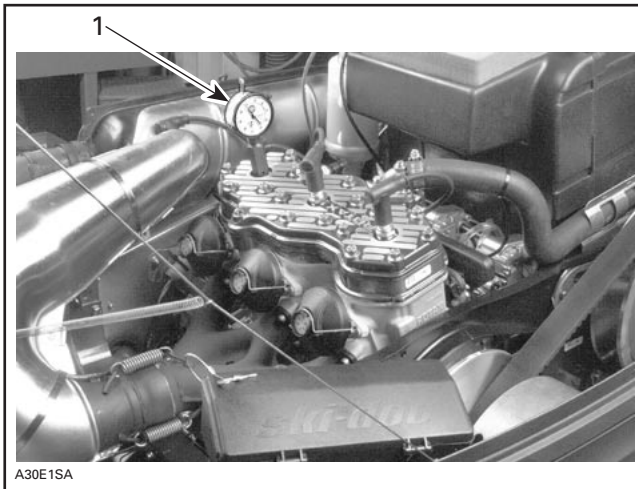

1. TDC gauge indicating specified timing

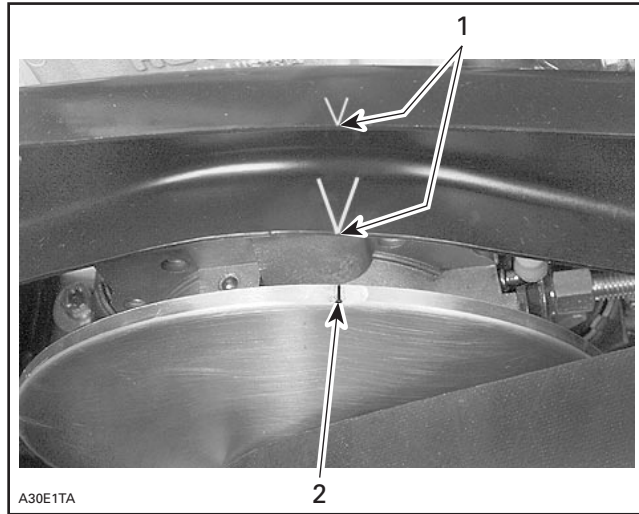

1. Marks on side member used as reference point
2. Timing mark in line with both marks on side member

Checking Ignition Timing

Use timing light (P/N 529 031 900).

To check the ignition timing, refer to illustration and proceed as follows:

⚠ WARNING

Place ski tips against a wall, raise rear of vehicle on a stand, so that track does not contact the ground. Do not allow anyone in front of or behind the vehicle while engine is running. Keep clear of track and do not wear loose clothing which can get caught in moving parts.

1. Connect the timing light pick-up to a spark plug cable.

NOTE: To avoid an incorrect reading due to parallax, view both marks scribed on removable side member and the timing mark in a straight line.

2. Start the engine and point timing light on timing mark. Bring engine to 3500 RPM for a brief instant.

Section 06 ELECTRICAL

Subsection 02 (IGNITION TIMING)

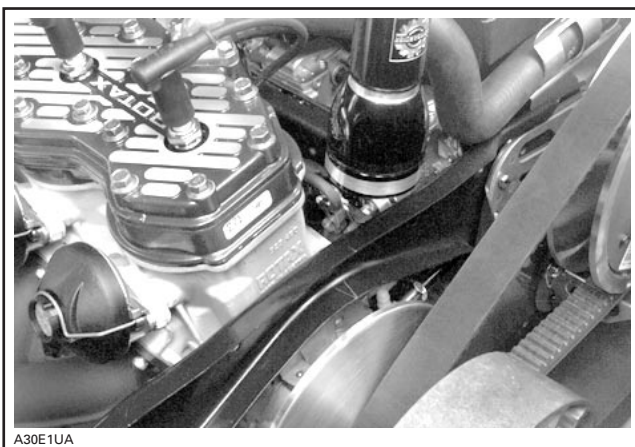

The timing mark must be aligned with both marks on side member. If not, note if timing is retarded or advanced. Tolerance is $\pm 1^\circ$.

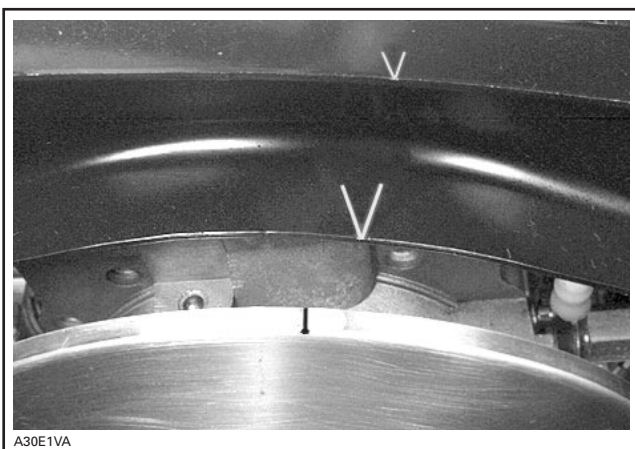

TIMING RETARDED BY ABOUT 2°

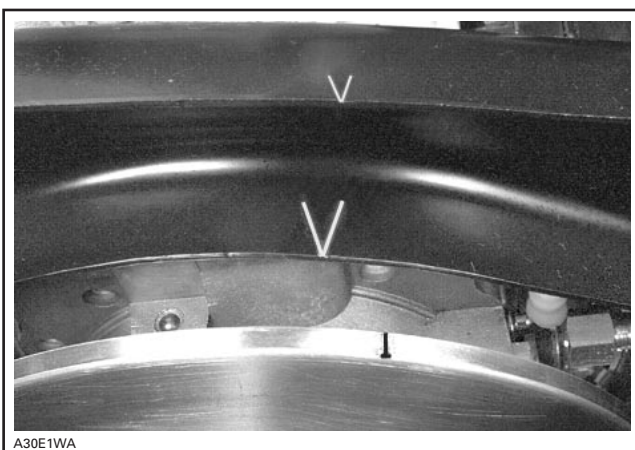

TIMING ADVANCED BY ABOUT 2°

Changing Timing

Timing can only be changed using the programmer (P/N 529 035 589).

Start engine. Turn on programmer then enter password.

Increase engine speed to 2500 RPM.

From main menu select no. 3. INFO VEHICLE.

1. CHECK KEYS
2. PROGRAM KEY
> 3. VEHICLE INFO
4+ START VEH.

A30E1XA

Engine will misfire during vehicle information is transferred from MPEM to programmer. If engine stalls, restart it, keep engine speed at 2500 RPM and select no. 3 VEHICLE INFO again.

TRANSFER
PGMR ← MPEM

A30E1YA

NOTE: In fact the programmer takes a **copy** of all vehicle parameters scribed in MPEM. This copy will be modified within the programmer then transferred to the MPEM.

Select no. 4. ENGINE PARAMETER.

1. CUSTOMER NAME
2. DELIVERY DATE
3. VEH. SERIAL#
> 4+ ENGINE PARAM.

A30E1ZA

Section 06 ELECTRICAL

Subsection 02 (IGNITION TIMING)

Select no. 1 TIMING ADJUSTMENT.

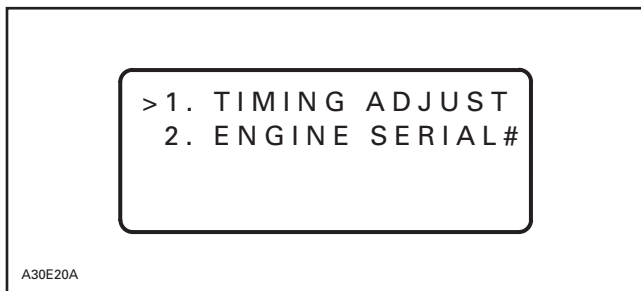

Press ENTER.

Now the display shows the engine timing correction factor that is programmed in the MPEM. In the following example timing correction factor is 4.

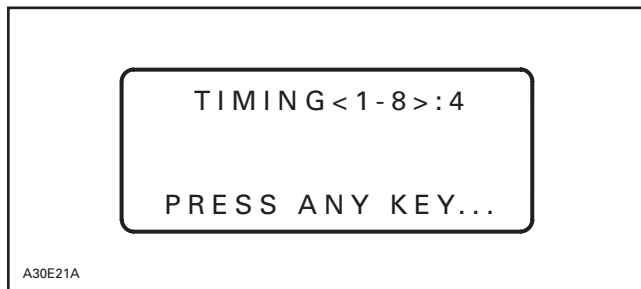

Press any key.

Select YES using the key \leftrightarrow .

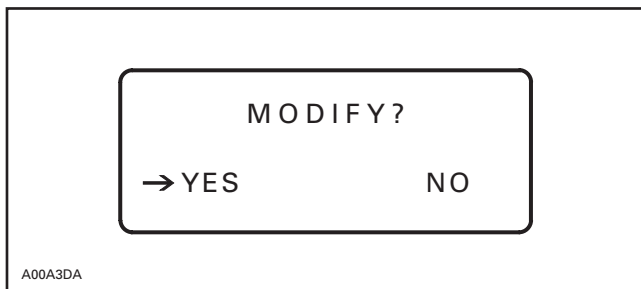

Press ENTER.

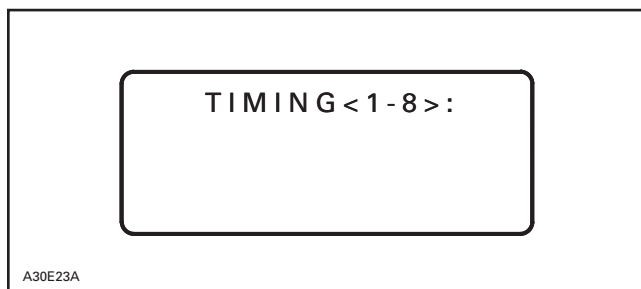

Select a timing correction factor corresponding to correction needed.

Example: Timing mark as verified with a timing light at 3500 RPM was too early by 2°. The correction factor programmed is no. 4.

Select correction factor no. 5. This will retard the timing by 2° because the difference between correction factor no. 4 and no. 5 is - 2° (passing from 1° to - 1°).

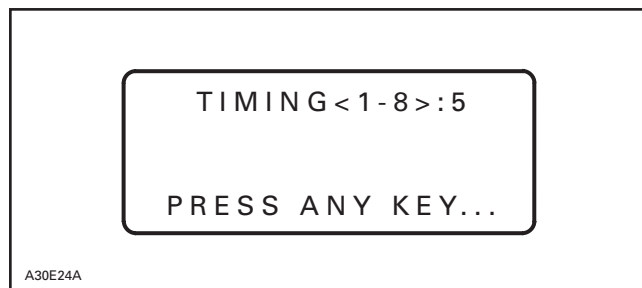

IGNITION CORRECTION FACTOR	
CORRECTION FACTOR PROGRAMMED IN MPEM	IGNITION TIMING CORRECTION
2	3°
3	2°
4	1°
1	0°
5	- 1°
6	- 2°
7	- 3°
8	- 4°

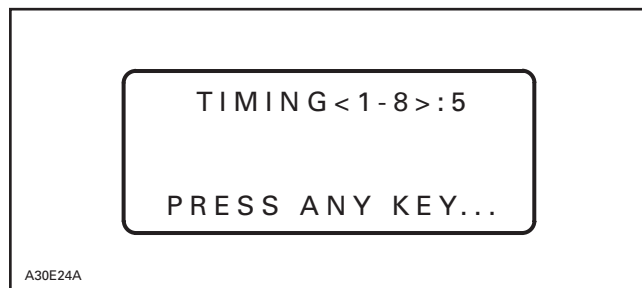

Section 06 ELECTRICAL
Subsection 02 (IGNITION TIMING)

Press ENTER.

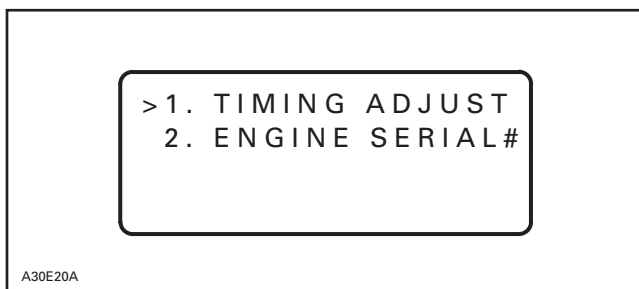

Press ENTER.

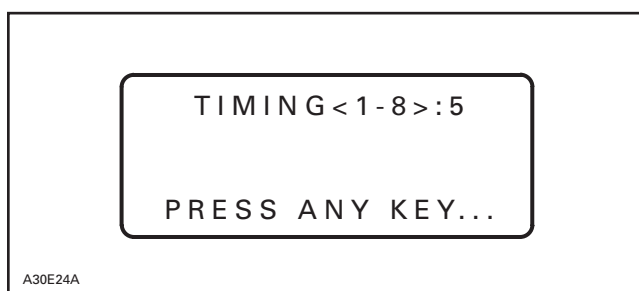

The display confirms that correction factor has been changed to no. 5.

Press any key.

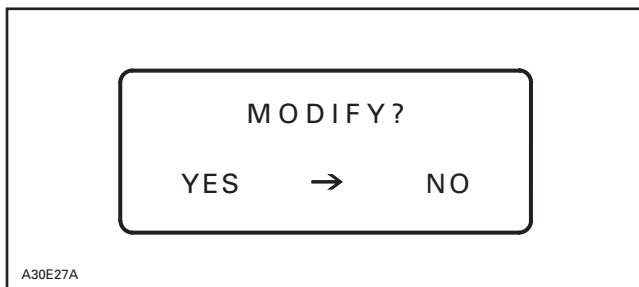

If the new correction factor selected above is the good one select NO and press ENTER. Otherwise select YES to choose another correction factor.

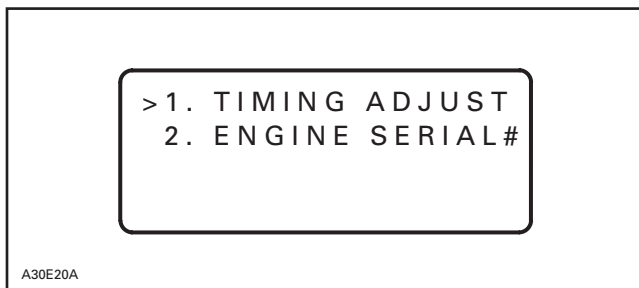

Press MENU.

Scroll to no. 7 SAVE AND QUIT.

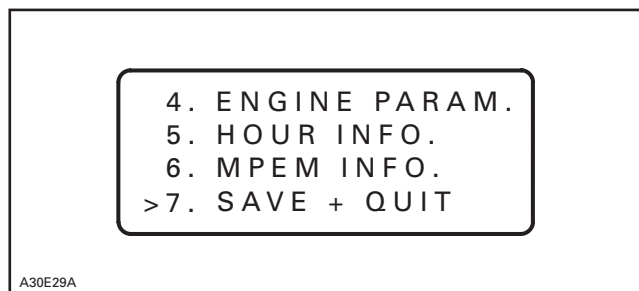

Press ENTER.

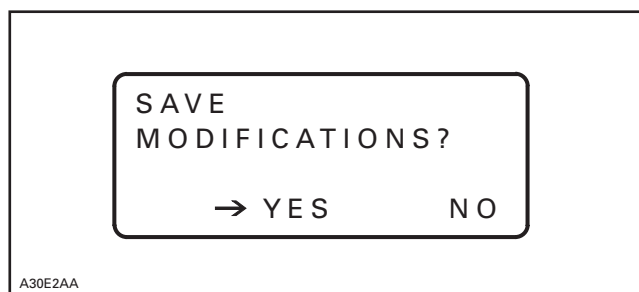

Increase engine speed to 2500 RPM.

Press ENTER.

Engine will misfire during vehicle information is transferred from programmer to MPEM. If engine stalls, restart it, keep engine speed at 2500 RPM and select no. 7 SAVE AND QUIT again.

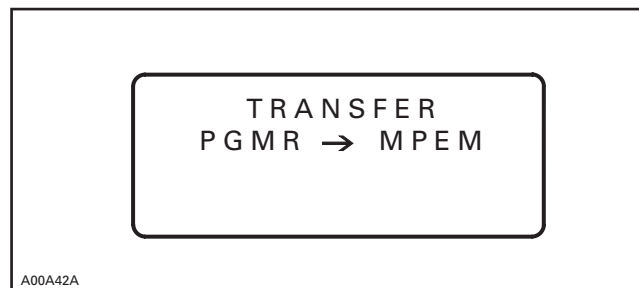

During a very short period of time the following message will appear.

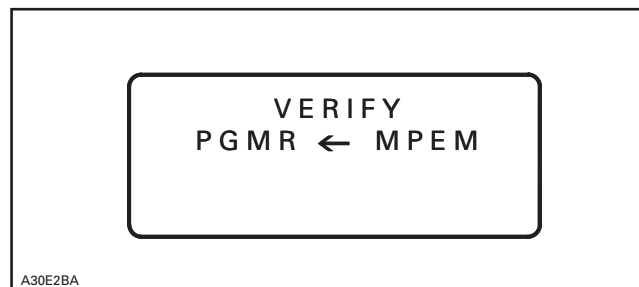

Section 06 ELECTRICAL

Subsection 02 (IGNITION TIMING)

After the programmer has verified, following message will appear.



Press any key.

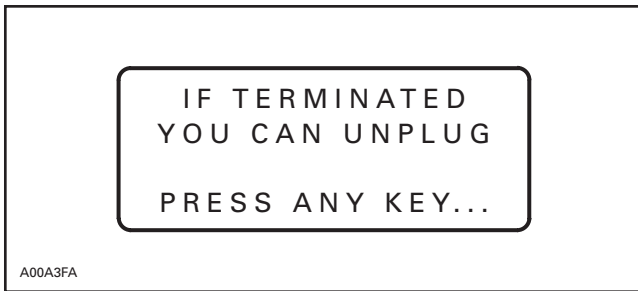

Press any key.

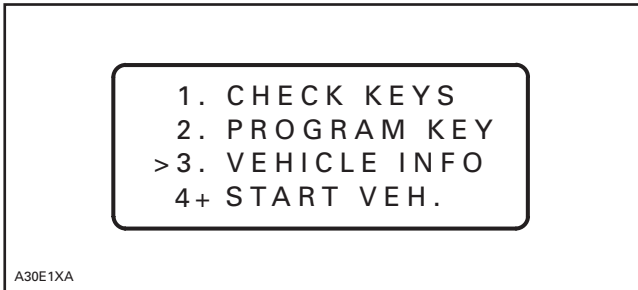

SPARK PLUGS

NGK SPARK PLUG

All Models

NGK SPARK PLUG NUMBERING SYSTEM

Bombardier uses NGK brand spark plugs on all its snowmobile models.

The heat range identification system is:

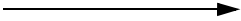
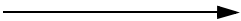
Low number  hot plug
High number  cold plug

Section 06 ELECTRICAL

Subsection 03 (SPARK PLUGS)

DESIGN SYMBOLS USED IN NGK SPARK PLUGS

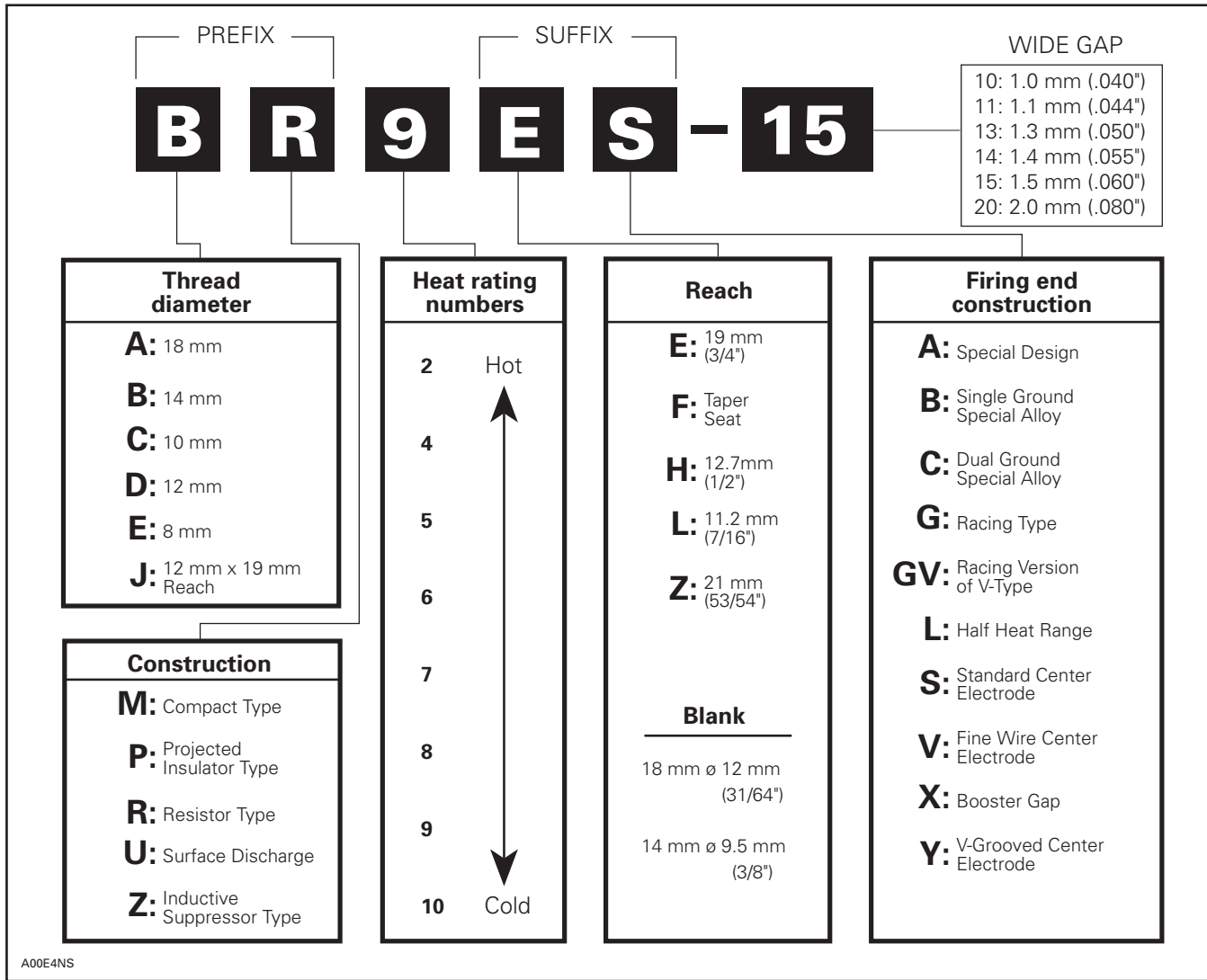

CROSSCUTS AND GAP STYLES OF SPARK PLUGS

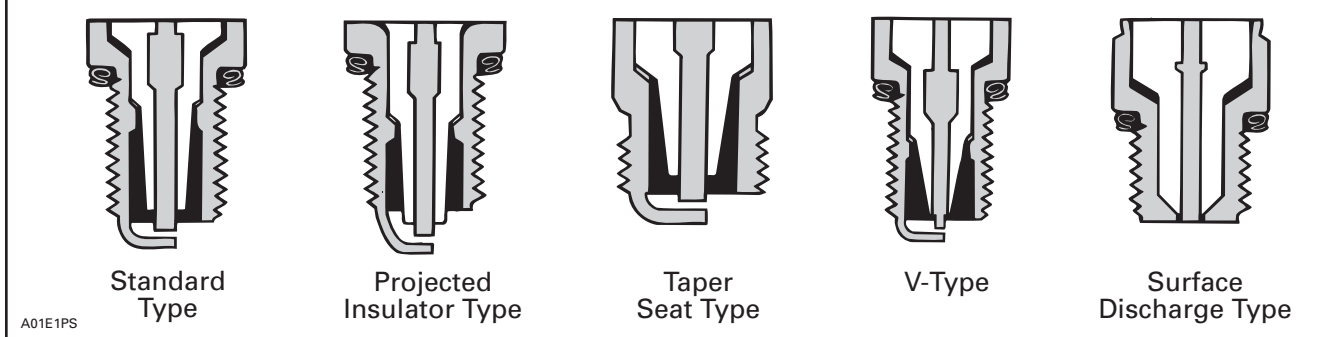

DISASSEMBLY

First unscrew the spark plug 1 turn.

Clean the spark plug and cylinder head with pressurized air, then completely unscrew.

WARNING

Whenever using compressed air, always wear protective eye wear.

HEAT RANGE

The proper operating temperature or heat range of the spark plugs is determined by the spark plug ability to dissipate the heat generated by combustion.

The longer the heat path between the electrode tip to the plug shell, the hotter the spark plug operating temperature will be — and inversely, the shorter the heat path, the colder the operating temperature will be.

A **cold** type plug has a relatively short insulator nose and transfers heat very rapidly into the cylinder head.

Such a plug is used in heavy duty or continuous high speed operation to avoid overheating.

The **hot** type plug has a longer insulator nose and transfers heat more slowly away from its firing end. It runs hotter and burns off combustion deposits which might tend to foul the plug during prolonged idle or low speed operation.

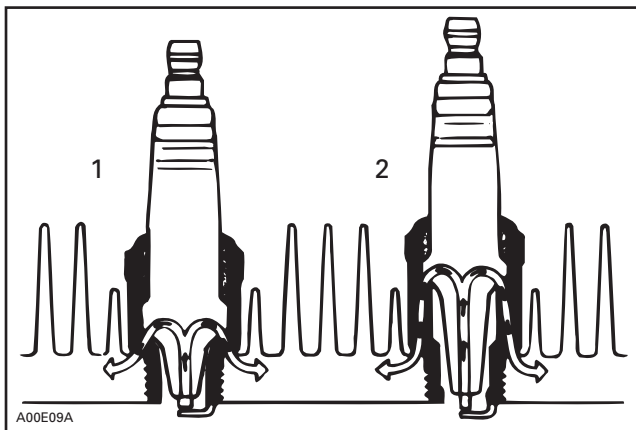

1. Cold
2. Hot

CAUTION: Severe engine damage might occur if a wrong heat range plug is used.

A **too hot** plug will result in overheating and pre-ignition, etc.

A **too cold** plug will result in fouling (shorting the spark plug) or may create carbon build up which can heat up red-hot and cause pre-ignition or detonation.

FOULING

Fouling of the spark plug is indicated by irregular running of the engine, decreased engine speed due to misfiring, reduced performance, and increased fuel consumption. This is due to a loss of compression. Other possible causes are: prolonged idling, or running on a too rich mixture due to a faulty carburetor adjustment or incorrect fuel and/or fuel mixing. The plug face of a fouled spark plug has either a dry coating of soot or an oily, glossy coating given by an excess either of oil or of oil with soot. Such coatings form a conductive connection between the center electrode and ground.

SPARK PLUG ANALYSIS

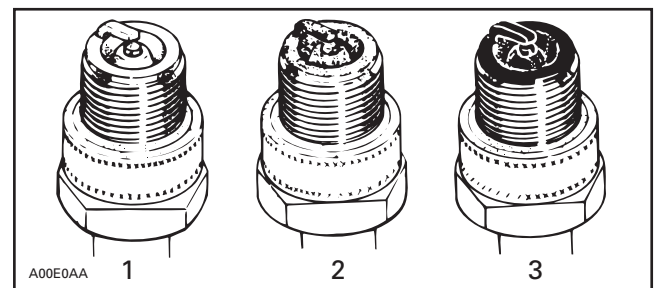

1. Overheated (light grey)
2. Normal (brownish)
3. Fouled (black)

The plug electrode and piston dome reveal the condition of the engine, operating condition, method of driving and fuel mixture. For this reason it is advisable to inspect the spark plug at regular intervals, examining the plug electrode and the piston dome.

Section 06 ELECTRICAL

Subsection 03 (SPARK PLUGS)

SPARK PLUG INSTALLATION

Prior to installation make sure that contact surfaces of the cylinder head and spark plug are free of grime.

1. Using a wire feeler gauge, set electrode gap according to TECHNICAL DATA 10.
2. Apply anti-seize lubricant (P/N 413 701 000) over the spark plug threads to prevent possible seizure.
3. Hand screw spark plug into cylinder head and tighten with a torque wrench and a proper socket.

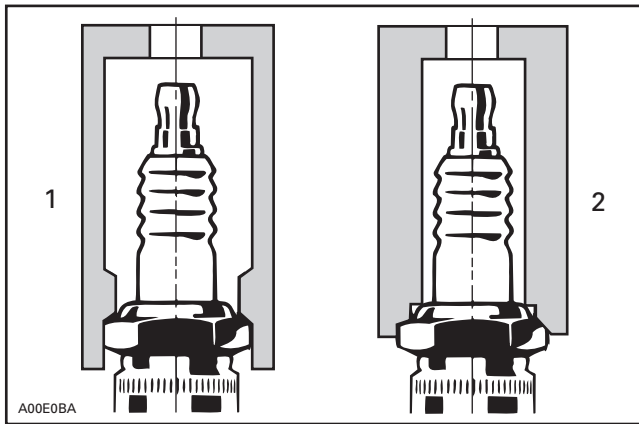

1. Proper socket
2. Improper socket

SPARK PLUG TIGHTENING TORQUE

MODELS	SPARK PLUGS	TORQUE N•m (lbf•ft)
All models	NGK	27 (20)

BATTERY

REMOVAL

All Models

⚠ WARNING

Battery BLACK negative cable must always be disconnected first and connected last.

⚠ WARNING

Never charge or boost battery while installed on vehicle.

Air Intake Silencer Removal

Grand Touring 700/SE Only

Unplug air temperature sensor connector from air intake silencer and remove MPEM, as shown in the next photo.

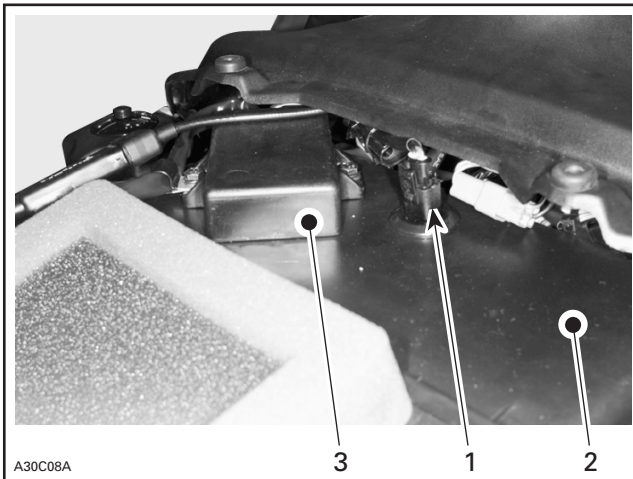

TYPICAL

1. Air temperature sensor
2. Air intake silencer
3. MPEM

Then twist DPM manifold and detach from air intake silencer.

All Models

Remove air intake silencer.

Unfasten battery retaining strips.

Open strips.

Remove vent tube.

Withdraw battery from vehicle being careful not lean it so that electrolyte flows out of vent tube.

CAUTION: Should any electrolyte spillage occur, immediately wash off with a solution of baking soda and water to prevent damage to vehicle components.

CLEANING

Clean the battery, battery casing, vent tube, caps, cables and battery posts using a solution of baking soda and water.

CAUTION: Do not allow cleaning solution to enter battery interior since it will destroy the electrolyte.

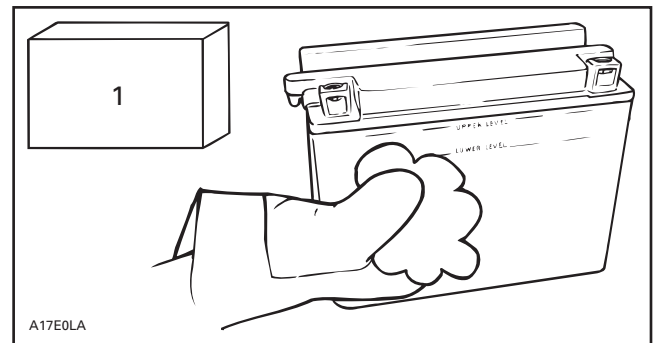

1. Baking soda

Remove corrosion from battery cable terminals and battery posts using a firm wire brush.

INSPECTION

Visually inspect battery case for cracks or other possible damage. If case is damaged, replace battery and thoroughly clean battery tray and close area with water and baking soda.

⚠ WARNING

Should the battery casing be damaged, wear a suitable pair of non-absorbent gloves when removing the battery by hand.

Inspect battery posts for security of mounting.

Inspect for cracked or damaged battery caps, replace defective caps.

⚠ WARNING

Battery caps do not have vent holes. Make sure that vent tube is not obstructed.

Section 06 ELECTRICAL

Subsection 04 (BATTERY)

HYDROMETER TEST

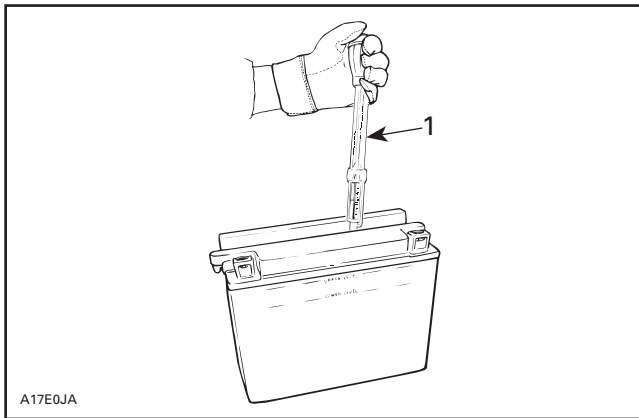

A17E0JA

1. Specific gravity 1.260

A hydrometer measures the charge of a battery in terms of specific gravity of the electrolyte. Most hydrometers give a true reading at 27°C (80°F).

In order to obtain correct readings, adjust the initial reading by **adding** .004 points to the hydrometer readings for each 5.5°C (10°F) **above** 27°C (80°F) and by **subtracting** .004 point for every 5.5°C (10°F) **below** 27°C (80°F).

This chart will be useful to find the correct reading.

ELECTROLYTE TEMPERATURE		OPERATION TO PERFORM
°C	°F	
38	100	add .008 to the reading .004
32	90	
27	80	CORRECT READING
21	70	subtract .004 .008 .012 .016 .020 .024 .028 .032 .036 .040 .044 .048 from the reading
16	60	
10	50	
4	40	
-1	30	
-7	20	
-12	10	
-18	0	
-23	-10	
-29	-20	
-34	-30	
-40	-40	

EXAMPLE NO. 1

Temperature below 27°C (80°F):

Hydrometer reading: 1.250

Electrolyte temperature: -7°C (20°F)

Subtract .024 Sp. Gr.

Corrected Sp. Gr. is 1.226

EXAMPLE NO. 2

Temperature above 27°C (80°F):

Hydrometer reading: 1.235

Electrolyte temperature: 38°C (100°F)

Add .008 Sp. Gr.

Corrected Sp. Gr. is 1.243

CAUTION: Do not install a partially charged battery on a snowmobile since the casing might crack at freezing temperature 0°C (32°F). The following chart shows the freezing point of the electrolyte in relation to the charge of the battery.

TEMPERATURE CORRECTED SPECIFIC GRAVITY	BATTERY CHARGE	FREEZING POINT OF ELECTROLYTE
1.260	Fully charged	-59°C (-74°F)
1.230	3/4 charged	-40°C (-40°F)
1.200	1/2 charged	-27°C (-16°F)
1.170	1/4 charged	-18°C (0°F)
1.110	Discharged	-7°C (+19°F)

BATTERY STORAGE

Disconnect and remove battery from the vehicle.

Check electrolyte level in each cell, add distilled water up to upper level line.

CAUTION: Do not overfill.

The battery must always be stored in fully charged condition. If required, charge until specific gravity of 1.260 is obtained.

CAUTION: Battery electrolyte temperature must not exceed 50°C (122°F). The casing should not feel hot.

Clean battery terminals and cable connections using a wire brush. Apply a light coat of dielectric grease (P/N 413 701 700) or petroleum jelly on terminals.

Clean battery casing and caps using a solution of baking soda and water. Do not allow cleaning solution to enter battery, otherwise it will destroy the electrolyte. Rinse battery with clear water and dry well using a clean cloth.

Store battery on a wooden shelf in a cool dry place. Such conditions reduce self-discharging and keep fluid evaporation to a minimum.

During the storage period, recheck electrolyte level and specific gravity readings at least every 40 days. As necessary, keep the battery at its upper level line and near full charge as possible (trickle charge).

ACTIVATION OF NEW BATTERY

⚠ WARNING

Never charge or boost battery while installed on vehicle.

CAUTION: Prior to charging the battery, always remove it from the vehicle to prevent electrolyte spillage.

A new battery is factory fresh dry charged. For storage purposes, it is fitted with a temporary sealing tube.

Do not remove the sealing tube or loosen battery caps unless activation is desired.

In case of accidental premature removal of caps or sealing tube, battery should be given a full charge.

Perform the following operations anytime a new battery is to be installed.

1. Remove the sealing tube from the vent elbow. Install vent tube, included in the battery kit, to battery elbow.

⚠ WARNING

Failure to remove the sealing tube could result in an explosion.

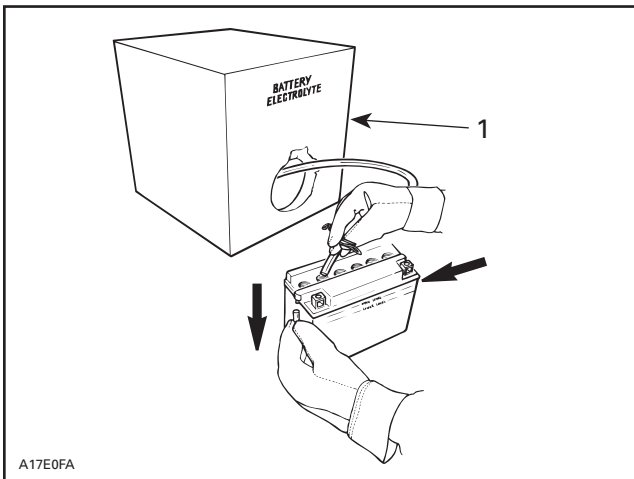

1. Battery electrolyte

2. Remove caps and fill battery to UPPER LEVEL line with electrolyte (specific gravity: 1.260 at 20°C (68°F)).

3. Allow the battery to stand for 30 minutes MINIMUM so that electrolyte soaks through battery cells.

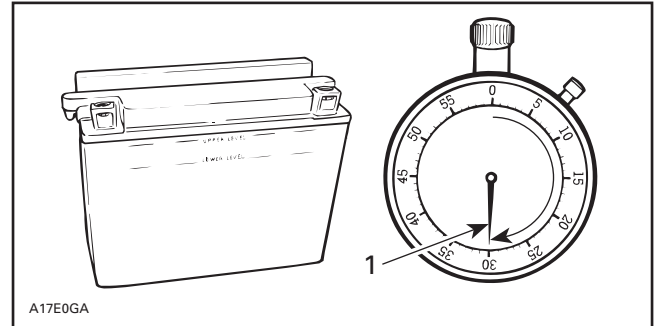

1. 30 minutes

4. Allow gas bubbles to escape by lightly shaking battery by hand.

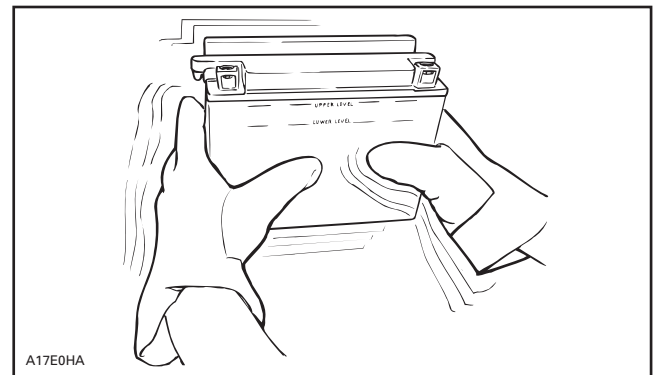

A17E0HA

5. Readjust the electrolyte level to the UPPER LEVEL line.

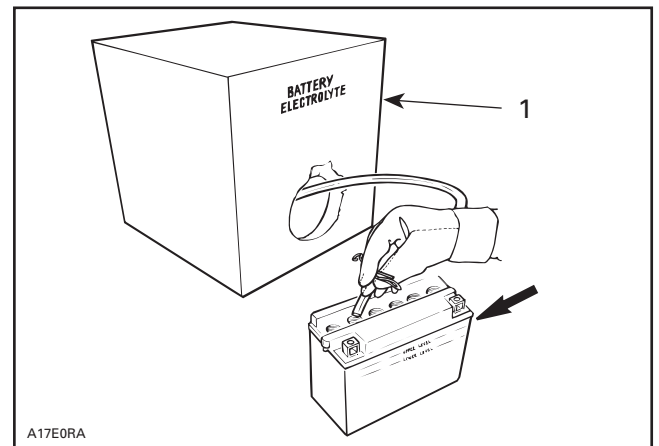

A17E0RA

1. Battery electrolyte

Section 06 ELECTRICAL

Subsection 04 (BATTERY)

6. Connect a 2 A battery charger for 10 to 20 hours.

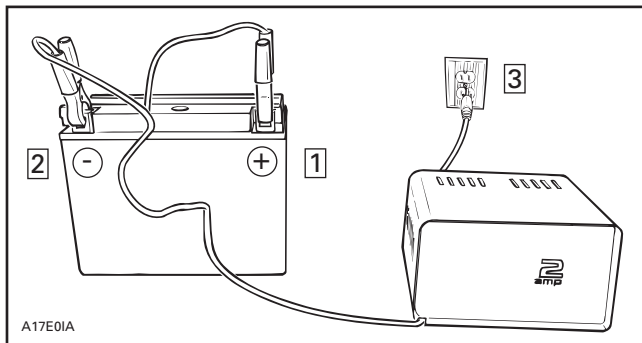

CAUTION: If charging rate raises higher than 2.4 A reduce it immediately. If cell temperature rises higher than 50°C (122°F) (if the casing feels hot) discontinue charging temporarily or reduce the charging rate.

⚠ WARNING

Gases given off by a battery being charged are highly explosive. Always charge in a well ventilated area. Keep battery away from cigarettes or open flames. Always turn battery charger off prior to disconnecting cables. Otherwise a spark will occur and battery might explode.

7. Disconnect battery charger.

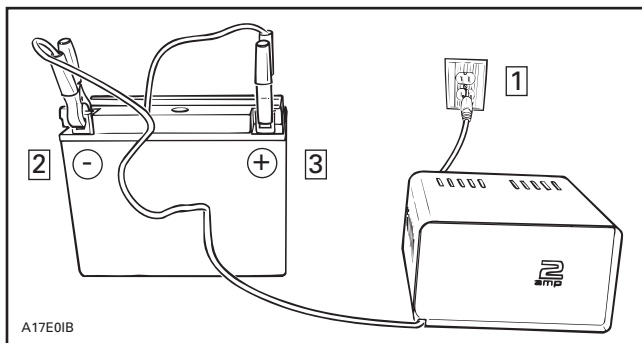

8. Test battery state of charge. Use a hydrometer.

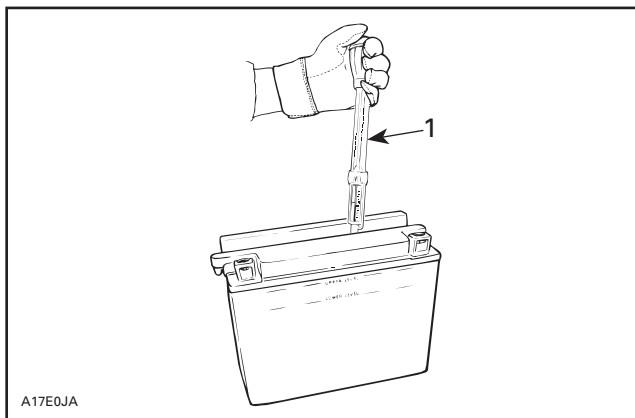

1. Specific gravity 1.260

9. Let battery settle for 1 hour.

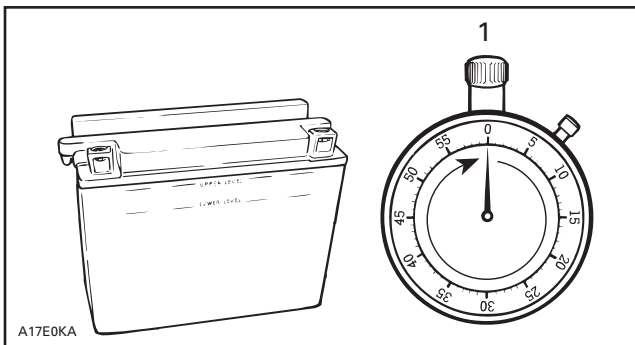

1. 60 minutes

10. Allow gas bubbles to escape by lightly shake battery.

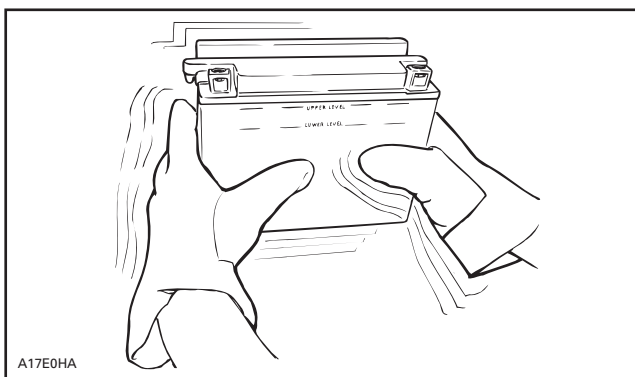

11. Readjust electrolyte level.

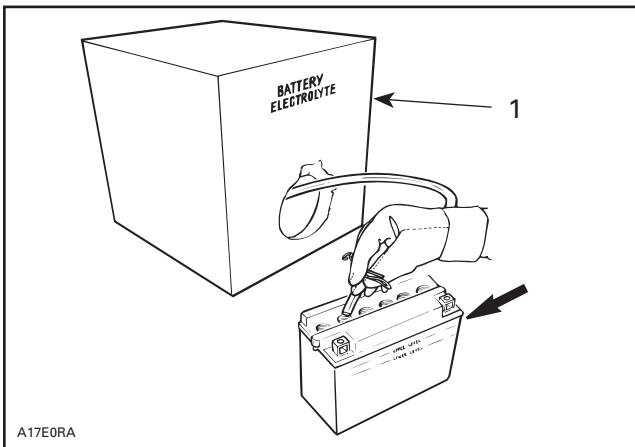

1. Battery electrolyte

12. Reinstall caps and clean any electrolyte spillage using a solution of baking soda and water.

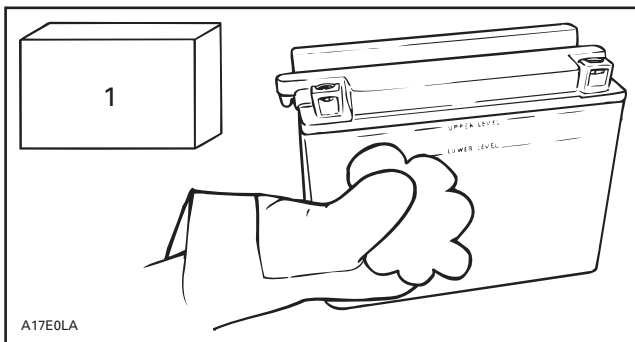

1. Baking soda

CAUTION: Do not allow cleaning solution to enter battery interior since it will destroy the electrolyte.

NOTE: It is recommended to verify the battery charge once a month. If necessary, fully charge battery.

SERVICING

Electrolyte Level

Since a battery has been activated (see above), add distilled water to top up electrolyte.

TIPS FOR CHARGING A USED BATTERY

CAUTION: Prior to charging the battery, always remove it from the vehicle to prevent electrolyte spillage.

For best results, battery should be charged when the electrolyte and the plates are at room temperature. A battery that is cold may not accept current for several hours after charging began.

Do not charge frozen battery. If the battery charge is very low, the battery may freeze. If it is suspected to be frozen, keep it in a heated area for about 2 hours before charging.

WARNING

Do not place battery near open flame.

Time required to charge a battery will vary depending on some factors such as:

- **Battery temperature:** Charging time is increased as the temperature goes down. The current accepted by a cold battery will remain low. As the battery warms up, it will accept a higher rate of charge.
- **State of charge:** Because the electrolyte is nearly pure water in a completely discharged battery, it cannot accept current as well as electrolyte. This is the reason the battery will not accept current when the charging cycle first begins. As the battery remains on the charger, the current from the charger causes the electrolytic acid content to rise which makes the electrolyte a better conductor and then, the battery will accept a higher charging rate.
- **Type of charger:** Battery chargers vary in the amount of voltage and current that they can supply. Therefore, time required for the battery to begin accepting measurable current will also vary.

Charging a Very Flat or Completely Discharged Battery

Unless this procedure is properly followed, a good battery may be needlessly replaced.

- Measure the voltage at the battery posts with an accurate voltmeter. If it is below 10 volts, the battery will accept current at very low rate, in terms of milliamperes, because electrolyte is nearly pure water as explained above. It could be some time before the charging rate increases. Such low current flow may not be detectable on some charger ammeters and the battery will seem not to accept any charge.
- Only for this particular case, set the charger to a high rate.

Section 06 ELECTRICAL

Subsection 04 (BATTERY)

NOTE: Some chargers have a polarity protection feature which prevents charging unless the charger leads are connected to the correct battery terminals. A completely discharged battery may not have enough voltage to activate this circuitry, even though the leads are connected properly. This will make it appear that the battery will not accept a charge. Follow the charger manufacturer's instruction telling how to bypass or override this circuitry so that the charger will turn on and charge a low-voltage battery.

- Since the battery chargers vary in the amount of voltage and current they provide, the time required for the battery to accept measurable charger current might be up to approximately 10 hours or more.
- If the charging current is not up to a measurable amount at the end of about 10 hours, the battery should be replaced.
- If the charging current is measurable before the end or at the end of about 10 hours, the battery is good and charging should be completed in the normal manner as specified in **Activation of a new battery**.
- It is recommended that any battery recharged by this procedure be load tested prior to returning it to service.

BATTERY CHARGING EQUIPMENT

The battery charger should have an adjustable charging rate. Variable adjustment is preferred, but a unit which can be adjusted in small increments is acceptable.

The battery charger must be equipped with an ammeter capable of accurately measuring current of less than one ampere.

If the present charger is not adjustable to the proper current values, a rheostat can be connected in series with the battery to provide adjustment. 12 ohm, 50 watt rheostat, such as OHMITE — 0314 or MALLORY 50K 12P, are available from electronic parts supply shops and they are suitable for use with most chargers if the peak current is to be held below 2 A.

If you need an accurate ammeter, we recommend the use of: SHURITE — 5202 (0 to 3 A) or — 5203 (0 to 5 A) available from electronic parts supply shops.

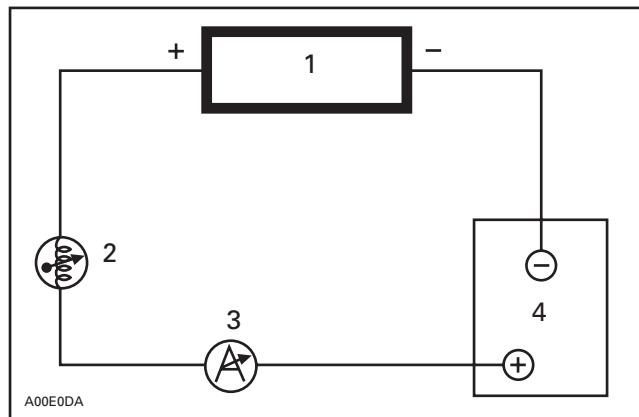

1. Charger
2. Rheostat 12 Ω 50 W
3. Ammeter
4. Battery

For a service application and a permanent installation, both ammeter and rheostat can be built into a small box adjacent to your charger.

CAUTION: Adequate ventilation **MUST** be provided to cool the rheostat.

Charging 2 or More Batteries at a Time

Connect all positives together and use a charger with a capacity (rated) equal to: number of batteries to be charged multiply by 2 A.

For example: Charging 5 batteries at a time requires a 10 A rated charger ($5 \times 2 \text{ A} = 10 \text{ A}$).

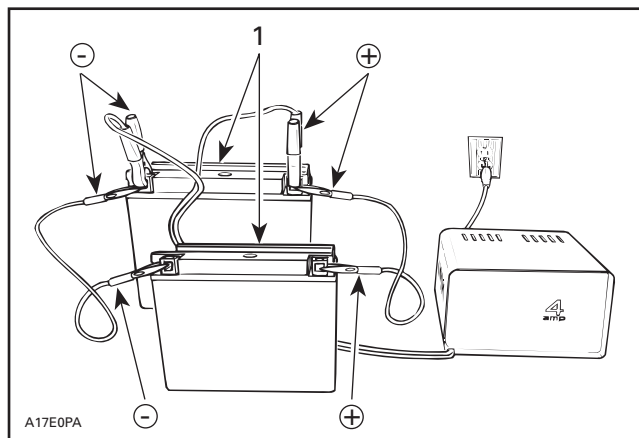

TYPICAL

1. Two batteries = 4 A

INSTALLATION OF BATTERY

Make sure that harness of oil reservoir low level sensor is positioned between fuel tank and battery strip.



REAR VIEW — FUEL TANK REMOVED FOR CLARITY

1. Harness of oil reservoir low level sensor

Position battery onto battery support on vehicle.

NOTE: To ease battery insertion, use soap with water.

Install vent tube on battery.

NOTE: Ensure that vent tube is not kinked or blocked. Cut vent tube if necessary.

Red Positive Cable and Wire

Move RED positive cable and wire from right side of engine compartment to battery positive post, as shown in the next photo.

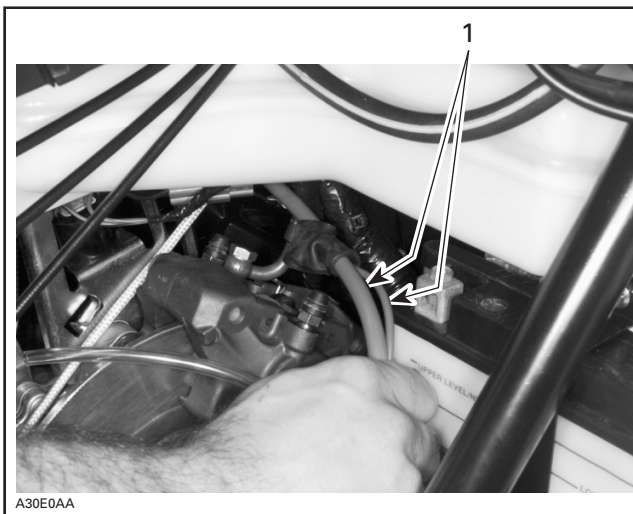

1. Move RED positive cable and wire

Connect RED positive cable and RED wire to positive battery terminal. Refer to the following photo for proper cable positioning.



RED POSITIVE (+) BATTERY CABLE AND WIRE POSITIONING

Black Negative Cable and Wires

Connect BLACK negative cable and BLACK wire LAST. Refer to the following photo for proper cable positioning.

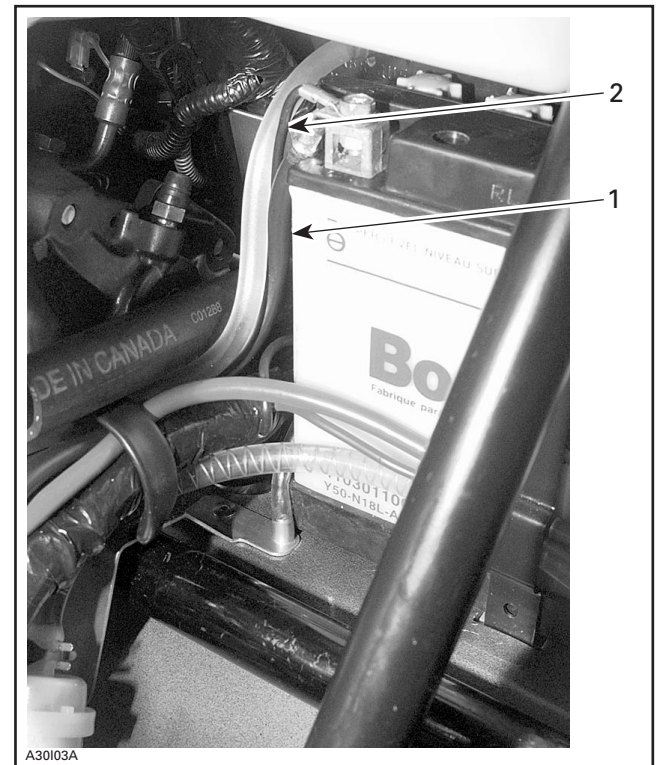

1. BLACK negative (-) battery cable
2. BLACK wire

Section 06 ELECTRICAL

Subsection 04 (BATTERY)

WARNING

Always connect the battery cables exactly in the specified order. Connect RED positive cable first, then BLACK negative ground cable.

Apply silicone dielectric grease (P/N 413 701 700) on battery posts and connectors.

Ensure vent tube is properly installed on battery elbow and chassis fitting.

Close and fasten retaining strips and ensure that RED positive battery cable and oil injection supply hose are routed into front retaining strip recess.

Reinstall air intake silencer with hose. On GT 700/SE, install DPM manifold, MPEM and air temperature sensor.

CAUTION: Negative battery terminal should always be disconnected **FIRST** and reconnected **LAST**.

ELECTRIC STARTER

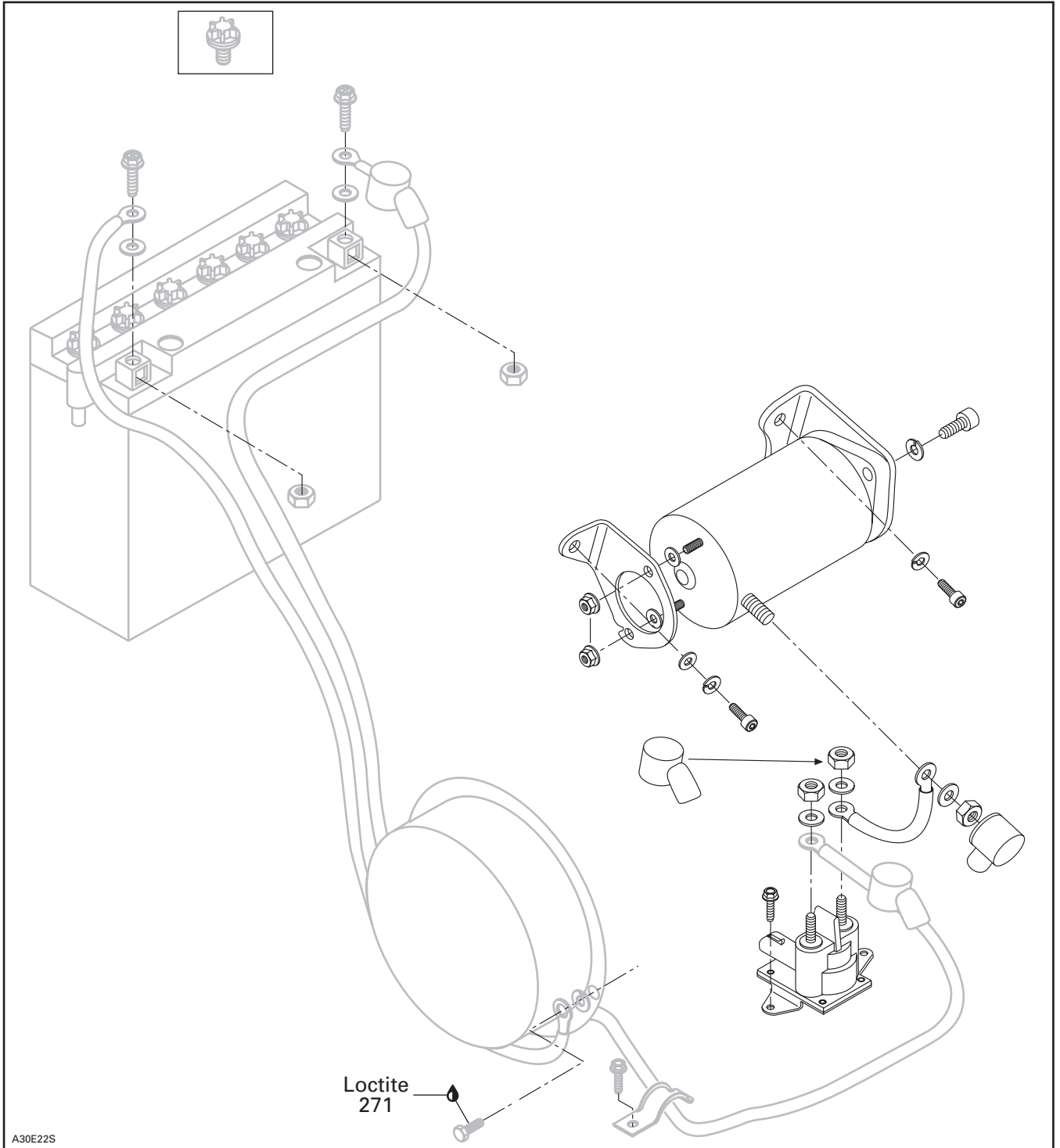

Section 06 ELECTRICAL

Subsection 05 (ELECTRIC STARTER)

REMOVAL

- Disconnect BLACK ground cable from battery.
- Disconnect RED positive cable from battery.
- Disconnect RED cable from starter solenoid switch.
- Remove starter from engine.

CAUTION: Support drive housing adequately to prevent damage when pressing bushing.

INSTALLATION

Make sure that starter and engine mating surfaces are free of grime. Serious trouble may arise if starter is not properly aligned.

Install starter.

NOTE: Check proper engaging depth of starter pinion teeth to ring gear teeth (see illustration). Install hardened washers (P/N 503 007 900) between engine and starter supports accordingly.

CAUTION: All starter bracket fasteners must be secured with Loctite 271 (P/N 413 707 400).

Connect RED cable to starter solenoid switch.
Connect the RED positive cable to battery.
Connect BLACK cable to battery.

WARNING

Always disconnect ground cable first and connect last.

SOLENOID SWITCH

Inspect connections and clean as necessary. Solenoid switch condition can be checked with an ohmmeter. Install test probes on **large** connectors of solenoid when it is activated (+ on RED/GREEN wire and - on solenoid body).

IMPORTANT: No current must be present on large cables when using ohmmeter, otherwise meter could be damaged.

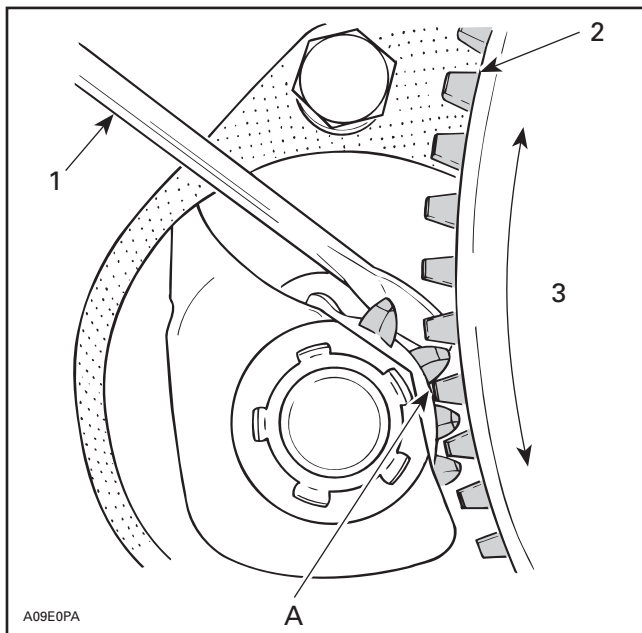

1. Screwdriver pulling starter pinion
2. Ring gear
3. No excessive backlash
- A. 0.5 to 1.5 mm (.020 to .060 in)

TESTING PROCEDURE

GENERAL

The following chart gives the engine types with their implemented system.

ENGINE TYPE	IGNITION SYSTEM	CHARGING SYSTEM OUTPUT
699 and 809 (except GT 700/SE)	① BOMBARDIER 290 W	290
699 and 809 on GT 700/SE	② BOMBARDIER 360 W	360

Multi-Purpose Electronic Module (MPEM) Identification

The BOMBARDIER 290 W MPEM receives electricity produced by 2 generating coils (low and high speed). It is smaller than the 360 W MPEM.

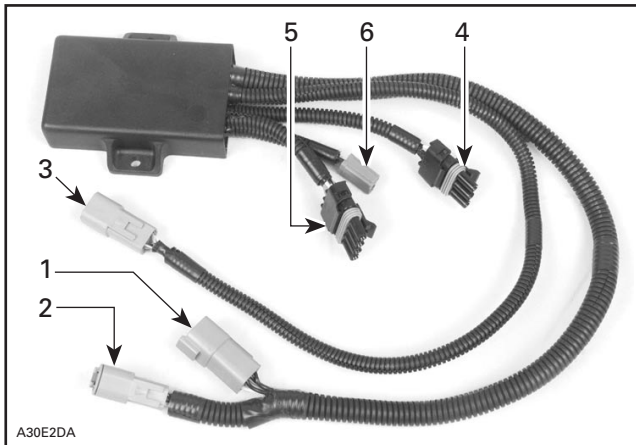

TYPICAL — BOMBARDIER 290 W MPEM — NON-RER MODELS

1. High tension coils, 4-DC housing
2. Generating coils (low and high speed), 4-DD housing
3. Trigger coil, 4-DF housing
4. DESS switch, 4-DB housing
5. DESS pilot lamp and ignition/kill switches, 4-DA housing
6. External power supply (for production use only) 4-DE housing

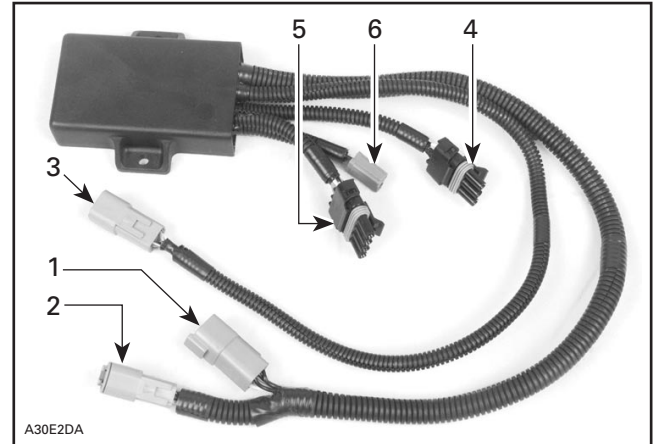

TYPICAL — BOMBARDIER 290 W MPEM — RER MODELS

1. High tension coils, 4-DC housing
2. Generating coils (low and high speed) and trigger coil, 4-DD housing
3. Trigger coil, 4-DF housing
4. DESS switch, 4-DF housing
5. Reverse switch and alarm, DESS pilot lamp and ignition/kill switches, 4-DA housing
6. External power supply (for production use only) 4-DE housing

The Bombardier 360 W MPEM receives DC electricity produced by the unique coil.

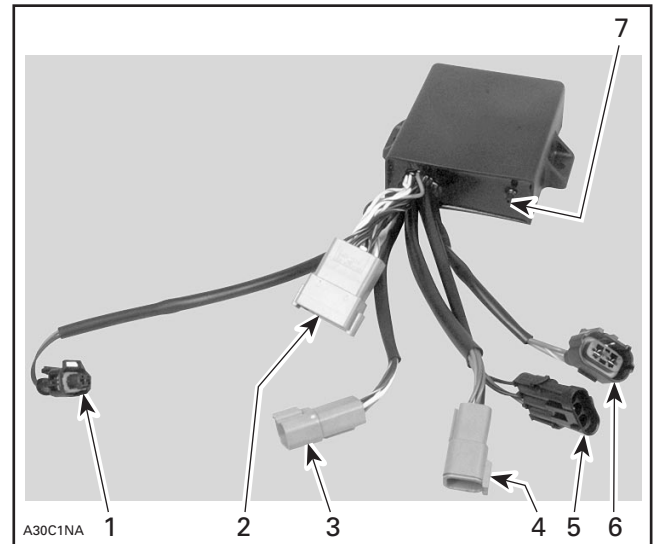

TYPICAL — BOMBARDIER 360 W MPEM

1. Air temperature sensor, 6-TA housing
2. Power supply, ground, DESS switch, reverse switch and alarm, high tension coils, kill switch, 6-DC housing
3. Trigger coils, 6-DB housing
4. DPM engine temperature sensor and solenoids, 6-VA housing
5. Enrichment switch, 6-ID housing
6. Battery/regulator connection, 6-DA housing
7. Atmospheric pressure nipple

Section 06 ELECTRICAL

Subsection 06 (TESTING PROCEDURE)

CAUTION: Do not interchange MPEM from a model to an other. Even if the P/N stamped on the MPEM is the same, calibration program may be different. When ordering a new MPEM always refer to appropriate model parts catalog. The service P/N published in parts catalogs are the ones with the good calibration program according to model.

At time of printing the programmer does not offer the possibility to see what calibration program is in the MPEM.

SYSTEM TESTING

IGNITION SYSTEM TESTING SEQUENCE

In the case of ignition problems, check the following in the prescribed order until the problem can be solved.

1. Sparking/spark plug condition.
2. Electrical connectors.
3. Ignition switches, DESS switch and emergency switch.
4. Ignition generator coil voltage.
5. Trigger coil.
6. Ignition module voltage.
7. High voltage coil output.
8. MPEM voltage supply.
9. MPEM.

LIGHTING SYSTEM TESTING SEQUENCE

1. Electrical connectors.
2. Magneto output (lighting generator coil).

Testing Conditions

Voltage measurements are always taken upon vehicle starting. Readings when the engine is running will be higher than indicated range. Part temperature must be approximately 20°C (68°F) (room temperature), otherwise readings could be distorted.

Analysis of Readings

Voltage Readings

When testing the different magneto components, it is important to take into consideration that readings vary according to the force applied onto the manual starter. It is therefore important to employ enough force upon each trial.

The reading must be 3 times within or above the range indicated in the corresponding table. If the reading is too low, the part is considered to be defective and must be replaced.

Resistance Readings

Place multimeter selector switch to Ω in order to measure resistance. Readings must be within the indicated range. Otherwise, the part is considered to be defective and must be replaced.

CAUTION: When taking measurements, it is useless to try to start the vehicle since readings would then be distorted.

Intermittent Ignition Problems

It is difficult to make a diagnostic in the case of intermittent ignition problems. Thus, problems occurring only when the engine operating temperature is normal must be checked in similar conditions.

In most cases when problems are caused by temperature or vibrations, these can only be solved by replacing parts. Most problems cannot be detected when the engine is stopped.

Multiple Problems

As a matter of fact, more than one component can be defective. As a result, if the problem remains although a part was replaced, start over the whole verification from the beginning in order to identify the other defective component.

1. SPARKING

During this operation, it is important to use the snowmobile spark plug and not a new one. Bring the plug in contact with the engine. If no spark is produced, replace the spark plug with a new one and do the test again.

2. ELECTRICAL CONNECTOR TESTING

Make sure that none of the connectors are disconnected.

Section 06 ELECTRICAL

Subsection 06 (TESTING PROCEDURE)

3. IGNITION SWITCH, TETHER CORD SWITCH AND EMERGENCY SWITCH TESTING

Disconnect connector housing from engine and check resistance as indicated in IGNITION table.

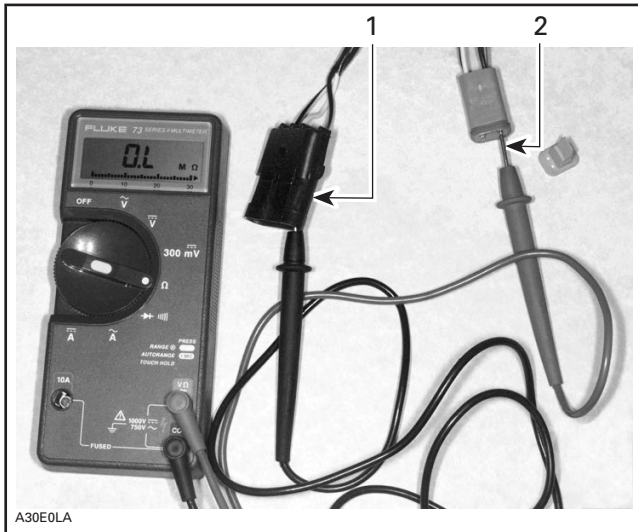

TYPICAL — 290 W

1. BK/YL wire, 4-DA-A-M housing (harness side)
2. BK wire, 4-DD-2-F housing (harness side)

If readings are acceptable, go on to next step.

If readings are inadequate, individually check each switch as follows.

DESS Switch

Tether Cord Switch

Unplug 4-DB housing (6-DC on 360 W models) connected to main wiring harness. Check using a multimeter by connecting probes to BLACK/GREEN and BLACK/WHITE wires. The multimeter should indicate a closed circuit ($0\ \Omega$) in operating position and a open circuit ($0.L\ M\Omega$) in off position.

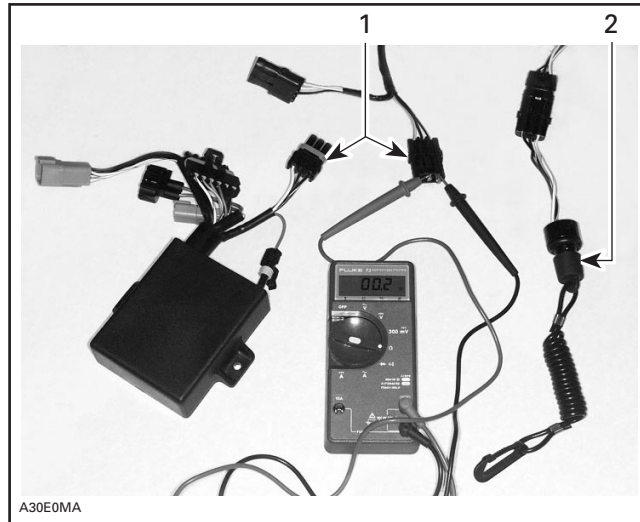

A30E0MA

TYPICAL — HARNESS REMOVED FOR CLARITY

1. 4-DB housing disconnected
2. DESS cap in place

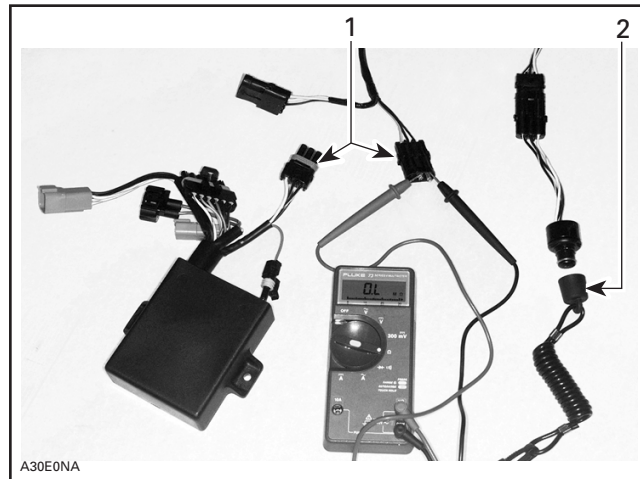

A30E0NA

TYPICAL — HARNESS REMOVED FOR CLARITY

1. 4-DB housing disconnected
2. DESS cap removed

DESS Switch Wire

Check continuity (null resistance) between switch center terminal and WHITE/GRAY wire connector.

Check continuity (null resistance) between switch side ring and BLACK/GREEN wire connector.

If readings do not correspond to the above mentioned indications, replace switch.

If none of these verifications are conclusive, the problem finds its source in the main wiring harness. Proceed as follows:

NOTE: For the next step, no switch must be connected to the main wiring harness.

Disconnect all switches from the main wiring harness and check the continuity of each wire by connecting probes to the end of wires of the same color. Repeat with all other wires. It is important to mention that all wires of the same color within a given harness are connected together. These wires should therefore have a closed circuit. On the other hand, BLACK and BLACK/YELLOW wires must have an open circuit (0.L MΩ).

Repair or replace if necessary.

4. IGNITION GENERATOR COIL VOLTAGE TESTING

290 W Models Only

General

When manually starting the engine while the spark plug is installed, the engine will tend to accelerate beyond the compression point. This will result in higher magneto output power.

1. Disconnect 4-DD housing between the magneto and the MPEM.
2. Connect multimeter probes to WHITE and RED wires and bring the selector switch to \checkmark and the scale to 00.0^{VAC}.
3. Activate the manual starter and check values indicated by the multimeter.
4. Repeat operation 3 times.
5. Compare readings with those appearing in the IGNITION table.

5. TRIGGER COIL TESTING

All Models

Resistance Testing

1. Connect probes to WHITE/YELLOW and BLUE/YELLOW wires from trigger coil 4-DF (6-DB on 360 W models) housing.
2. Activate the manual starter and check values indicated by the multimeter.
3. Repeat operation 3 times.
4. Compare readings with those appearing in the IGNITION table.

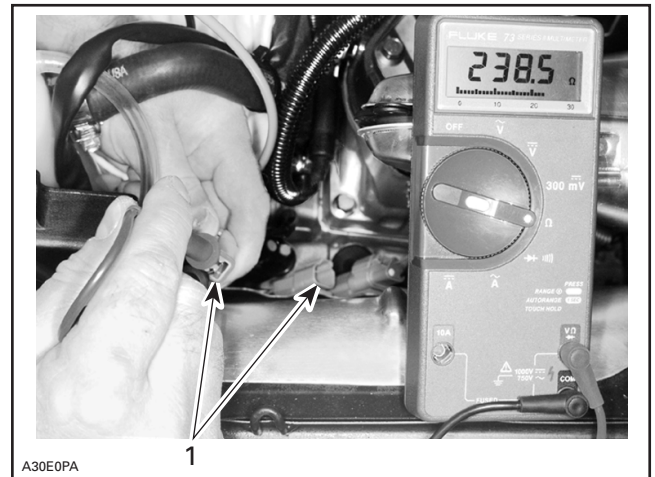

1. 10-04 housing

6. MPEM VOLTAGE TESTING

All Models

1. Disconnect the 4-DC (2-DG on GT 700/SE) housing between module and high voltage coils.
2. Connect multimeter probes to WHITE/BLUE and BLACK wires coming out from module. Place the selector switch to \checkmark and the scale to 00.0^{VAC}.
3. Activate the manual starter and check values indicated by the multimeter.
4. Repeat operation 3 times.
5. Compare readings with those appearing in the IGNITION table.

Section 06 ELECTRICAL

Subsection 06 (TESTING PROCEDURE)

7. HIGH VOLTAGE COIL VOLTAGE TESTING

1. Disconnect spark plug cap from spark plug.
2. Fasten alligator clip to spark plug cable, near the spark plug.
3. Connect other multimeter wire to engine (ground), then place selector switch to \checkmark and scale to 0.00^{Vac} .
4. Activate the manual starter and check values indicated by the multimeter.
5. Repeat operation 3 times.
6. Compare readings with those appearing in the IGNITION table.

8. MPEM SUPPLY VOLTAGE TESTING

Grand Touring 700/SE Only

1. Disconnect the 6-DA and 6-DC housings between module and main harness.
2. Connect multimeter probes to RED/BLUE and BLACK wires coming out from harness. Place the selector switch to \checkmark and the scale to 00.0^{Vdc} .
3. Activate the manual starter and check values indicated by the multimeter.
4. Repeat operation 3 times.
5. Compare readings with those appearing in the IGNITION table.

9. MPEM TESTING

Grand Touring 700/SE Only

1. Disconnect the MPEM.
2. Install a known-good MPEM.
3. Activate the manual starter and check values indicated by the multimeter.

CONCLUSION

All Models

If none of the above testing operations produced valid results, it is strongly recommended to keep on testing according to the list appearing in the Resistance column of the IGNITION table.

Set the multimeter as indicated.

LIGHTING GENERATOR COIL VOLTAGE TESTING

NOTE: For 290 W system, the lighting generator coil is not part of the ignition system. It is a self-contained system used to supply current to the lighting system and to other devices working on alternating current. However, this system can be tested using a multimeter.

1. Disconnect round 2-MO housing from engine (YELLOW, YELLOW wires).
2. Connect multimeter probes to YELLOW wires, then place selector switch to \checkmark and scale to 0.00^{Vac} .
3. Activate the manual starter and check values indicated by the multimeter.
4. Repeat operation 3 times.

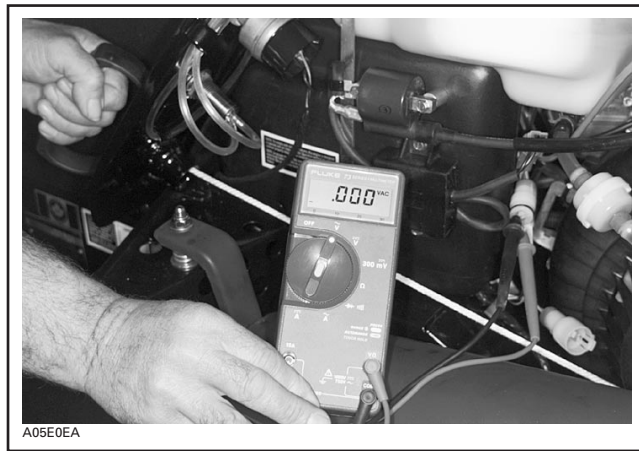

TYPICAL

5. Compare readings with those appearing in the LIGHTING table.

CONCLUSION

If none of the above testing operations produced valid results, it is strongly recommended to keep on testing according to the list appearing in the Resistance column of the LIGHTING table.

Set the multimeter as indicated.

ELECTRIC ACCESSORIES TESTING

Grand Touring 700/SE Only

All accessories are supplied with electricity only when engine is running at 800 RPM or faster.

The MPEM controls the electricity supply to accessories. To short-circuit this feature, avoiding to let engine idling during testing, connect the bypass wires (P/N 529 033 300).

1. Disconnect the 6-DA housing.
2. Connect bypass wires (P/N 529 033 300) to the harness housing in series into the 6-DA housing.
3. Turn bypass switch on. All accessories receive the battery voltage.

Section 06 ELECTRICAL

Subsection 06 (TESTING PROCEDURE)

IGNITION SYSTEM TESTING (CK3 SERIES — 290 W NON-RER)								
Part	Test to be performed	Wire color	Multimeter probe connection	Resistance Ω		Voltage V		Note
				Value (Ohms)	Multimeter scale	Value (Volts)	Multimeter scale	
Ignition and kill switches	Running insulation	BK and BK/YL	4-DD-2-F 4-DA-A-M	0.L	00.0 _M Ω	—	—	No stop switch must be operational.
	Continuity in stop position	BK and BK/YL	4-DD-2-F 4-DA-A-M	00.0 - 00.5	00.0 _{Ω}	—	—	Only one stop switch must be operational. Test one at a time.
DESS switch	Insulation in stop position	BK/GN and BK/WH	4-DB-B-M 4-DB-C-M	0.L	00.0 _M Ω	—	—	Tether cord cap should be off.
	Running continuity	BK/GN and BK/WH	4-DB-B-M 4-DB-C-M	00.0 - 00.5	00.0 _{Ω}	—	—	Tether cord cap should be in place.
Ignition generator coil	Output	WH and RD	4-DD-3-F 4-DD-1-F	25.0 - 56.0	00.0 _{Ω}	30.0 - 50.0	00.0 ^{vac}	—
		WH and BK/RD	4-DD-3-F 4-DD-4-F	3.5 - 8.1	00.0 _{Ω}	4.0 - 10.0	00.0 ^{vac}	—
	Coil insulation	BK and RD	4-DD-2-F 4-DD-1-F	0.L	00.0 _M Ω	—	—	—
	Ground continuity	BK and engine	4-DD-2-F and engine	00.0 - 00.5	00.0 _{Ω}	—	—	The term "engine" refers to the engine metal parts connected to the magneto housing.
Trigger coil	Resistance and output	WH/YL and BL/YL	4-DF-2-F 4-DF-1-F	190 - 300	00.0 _{Ω}	.200 - .350	.000 ^{vac}	—
MPEM	Output voltage	WH/BL and BK	4-DC-(1,2,3)-M 4-DC-(6,5,4)-M	—	—	10.0 - 20.0 3 times	00.0 ^{vac}	No switch must be operational and tether cord cap must be in place.
High voltage coil	Primary winding resistance	WH/BL and BK	4-DC-(1,2,3)-F 4-DC-(6,5,4)-F	00.2 - 00.5 3 times	00.0 _{Ω}	—	—	—
	Secondary winding resistance (spark plug cap included)	Spark plug cap and engine	In spark plug cap and on engine	10.5 K - 19 K 3 times	00.0 _K Ω	CAUTION: Do not measure high voltage coil output voltage.		
	Secondary winding resistance (without spark plug cap)	BK and engine	In spark plug wire and on engine	6 K - 13 K 3 times	00.0 _K Ω	CAUTION: Do not measure high voltage coil output voltage.		
	Secondary winding voltage	BK and engine	On spark plug wire and on engine	—	—	1.5 - 2.5 3 times	0.00 ^{vac}	The measurement must be taken on the spark plug wire (without the spark plug).
Spark plug cap	Cap resistance	—	Spark plug side and wire side	4.0 K - 6.0 K 3 times	00.0 _K Ω	—	—	—

M: Male

F: Female

Section 06 ELECTRICAL
Subsection 06 (TESTING PROCEDURE)

IGNITION SYSTEM TESTING (CK3 SERIES — 290 W RER)								
Part	Test to be performed	Wire color	Multimeter probe connection	Resistance Ω		Voltage V		Note
				Value (Ohms)	Multimeter scale	Value (Volts)	Multimeter scale	
Ignition and kill switches	Running insulation	BK and BK/YL	4-DD-2-F 4-DA-A-M	0.L	00.0 $M\Omega$	—	—	No stop switch must be operational.
	Continuity in stop position	BK and BK/YL	4-DD-2-F 4-DA-A-M	00.0 - 00.5	00.0 Ω	—	—	Only one stop switch must be operational. Test one at a time.
DESS switch	Insulation in stop position	BK/GN and BK/WH	4-DB-B-M 4-DB-C-M	0.L	00.0 Ω	—	—	Tether cord cap should be off.
	Running continuity	BK/GN and BK/WH	4-DB-B-M 4-DB-C-M	00.0 - 00.5	00.0 Ω	—	—	Tether cord cap should be in place.
Ignition generator coil	Output	WH and RD	4-DD-3-F 4-DD-1-F	25.0 - 56.0	00.0 Ω	30.0 - 50.0	00.0 V_{vac}	—
		WH and BK/RD	4-DD-3-F 4-DD-4-F	3.5 - 8.1	00.0 Ω	4.0 - 10.0	00.0 V_{vac}	—
	Coil insulation	BK and RD	4-DD-2-F 4-DD-1-F	0.L	00.0 $M\Omega$	—	—	—
	Ground continuity	BK and engine	4-DD-2-F and engine	00.0 - 00.5	00.0 Ω	—	—	The term "engine" refers to the engine metal parts connected to the magneto housing.
Trigger coil no. 1	Resistance and output	WH/YL and BL/YL	4-DF-3-F 4-DF-4-F	190 - 300	00.0 Ω	.200 - .350	.000 V_{vac}	—
Trigger coil no. 2	Resistance and output	GY/YL and GN/YL	4-DF-2-F 4-DF-1-F	190 - 300	00.0 Ω	.200 - .350	.000 V_{vac}	—
MPEM	Output voltage	WH/BL and BK	4-DC-(1,2,3)-M 4-DC-(6,5,4)-M	—	—	10.0 - 20.0 3 times	00.0 V_{vac}	No switch must be operational and tether cord cap must be in place.
High voltage coil	Primary winding resistance	WH/BL and BK	4-DC-(1,2,3)-F 4-DC-(6,5,4)-F	00.2 - 00.5 3 times	00.0 Ω	—	—	—
	Secondary winding resistance (spark plug cap included)	Spark plug cap and engine	In spark plug cap and on engine	10.5 K - 19 K 3 times	00.0 $K\Omega$	CAUTION: Do not measure high voltage coil output voltage.		
	Secondary winding resistance (without spark plug cap)	BK and engine	In spark plug wire and on engine	6 K - 13 K 3 times	00.0 $K\Omega$	CAUTION: Do not measure high voltage coil output voltage.		
	Secondary winding voltage	BK and engine	On spark plug wire and on engine	—	—	1.5 - 2.5 3 times	0.00 V_{vac}	The measurement must be taken on the spark plug wire (without the spark plug).
Spark plug cap	Cap resistance	—	Spark plug side and wire side	4.0 K - 6.0 K 3 times	00.0 $K\Omega$	—	—	—

M: Male F: Female

NOTE: Stop switches include the ignition switch and the emergency cut-out switch.

It is important to take note that voltage measurements must be taken while starting the vehicle using the manual starter.

Voltages obtained upon starting are proportional to the force applied onto the manual starter. A low voltage is therefore normal under a low cranking force.

Perform testing in the prescribed order and replace any parts not performing according to specifications.

It is important to resume all tests when replacing a component.

If not specified, the probe connecting sequence is not important.

Section 06 ELECTRICAL

Subsection 06 (TESTING PROCEDURE)

LIGHTING SYSTEM TESTING (CK3 SERIES — 290 W)								
Part	Test to be performed	Wire color	Multimeter probe connection	Resistance Ω		Voltage V		Note
				Value (Ohms)	Multimeter scale	Value (Volts)	Multimeter scale	
Lighting generator coil	Output	YL and YL	2-MO-B-F and 2-MO-C-F	00.15 - 00.35	00.0 Ω	3.0 - 7.0	00.0 ^{Vac}	—
	Coil insulation	YL and engine	2-MO-(B,C)-F and engine	0.L	00.0 $M\Omega$	—	—	The term "engine" refers to the engine metal parts connected to the magneto housing.
	Ground continuity	BK and engine	2-MO-A-F and engine	00.0 - 00.5	00.0 Ω	—	—	

M: Male

F: Female

NOTE: It is important to take note that voltage measurements must be taken while starting the vehicle using the manual starter.

Voltages obtained upon starting are proportional to the force applied onto the manual starter. A low voltage is therefore normal under a low cranking force.

Perform testing in the prescribed order and replace any parts not performing according to specifications.

It is important to resume all tests when replacing a component.

If not specified, the probe connecting sequence is not important.

Section 06 ELECTRICAL
Subsection 06 (TESTING PROCEDURE)

IGNITION SYSTEM TESTING (CK3 SERIES — 360 W)								
Part	Test to be performed	Wire color	Multimeter probe connection	Resistance Ω		Voltage V		Note
				Value (Ohms)	Multimeter scale	Value (Volts)	Multimeter scale	
Ignition and kill switches	Running insulation	BK and BK/YL	6-DC-9-F 6-DC-3-F	0.L	00.0 $M\Omega$	—	—	No stop switch must be operational.
	Continuity in stop position	BK and BK/YL	6-DC-9-F 6-DC-3-F	00.0 - 00.5	00.0 Ω	—	—	Only one stop switch must be operational. Test one at a time.
DESS switch	Insulation in stop position	BK/GN and BK/WH	6-DC-2-F 6-DC-1-F	0.L	00.0 $M\Omega$	—	—	Tether cord cap must be off.
	Running continuity	BK/GN and BK/WH	6-DC-2-F 6-DC-1-F	00.0 - 00.5	00.0 Ω	—	—	Tether cord cap must be in place.
MPEM	Supply from GY wire	RD/GY and BK	6-DC-10-F 6-DC-9-F	—	—	Battery voltage within 0.5	00.0Vdc	—
	Supply from RD/BL wire	RD/BL and BK	6-DA-A-M 6-DC-9-F	—	—	2.00 - 3.50	00.0Vdc	—
	Supply from RD/WH wire	RD/WH and BK	6-DA-B-M 6-DC-9-F	—	—	Battery voltage within 0.5	00.0Vdc	—
	Ground continuity	BK and engine	6-DC-9-F and engine	00.0 - 00.5	00.0 Ω	—	—	The term "engine" refers to the engine metal parts connected to the magneto housing.
Trigger coil no. 1	Resistance and output	WH/YL and BL/YL	6-DB-1-F 6-DB-4-F	190 - 300	00.0 Ω	.200 - .350	.000Vdc	The test can be done on 2-BE housing, but this would not validate the harness.
Trigger coil no. 2	Resistance and output	GY/YL and GN/YL	6-DB-3-F 6-DB-2-F	190 - 300	00.0 Ω	.200 - .350	.000Vdc	The test can be done on 2-BE housing, but this would not validate the harness.
Ignition module	Output voltage	WH/BL and BK	2-DG-(1,2,3)-M 2-DG-(6,5,4)-M	—	—	10.0 - 20.0 3 times	00.0Vdc	No switch must be operational and tether cord cap must be in place.
High voltage coil	Primary winding resistance	WH/BL and BK	2-DG-(1,2,3)-F 2-DG-(6,5,4)-F	00.2 - 00.5 3 times	00.0 Ω	—	—	—
	Secondary winding resistance (spark plug cap included)	Spark plug cap and engine	In spark plug cap and on engine	10.5 K - 19 K 3 times	00.0 $K\Omega$	CAUTION: Do not measure high voltage coil output voltage.		
	Secondary winding resistance (without spark plug cap)	BK and engine	In spark plug wire and on engine	6 K - 13 K 3 times	00.0 $K\Omega$	CAUTION: Do not measure high voltage coil output voltage.		
	Secondary winding voltage	BK and engine	On spark plug wire and on engine	—	—	1.5 - 2.5 3 times	0.00Vdc	The measurement must be taken on the spark plug wire (without the spark plug).
Spark plug cap	Cap resistance	—	Spark plug side and wire side	4.0 K - 6.0 K 3 times	00.0 $K\Omega$	—	—	—

M: Male F: Female

NOTE: Stop switches include the ignition switch, and the emergency cut-out switch.

It is important to take note that voltage measurements must be taken while starting the vehicle using the manual starter.

Voltages obtained upon starting are proportional to the force applied onto the manual starter. A low voltage is therefore normal under a low cranking force.

Perform testing in the prescribed order and replace any parts not performing according to specifications.

It is important to resume all tests when replacing a component.

If not specified, the probe connecting sequence is not important.

Section 06 ELECTRICAL

Subsection 06 (TESTING PROCEDURE)

LIGHTING SYSTEM TESTING (CK3 SERIES — 360 W)								
Part	Test to be performed	Wire color	Multimeter probe connection	Resistance Ω		Voltage V		Note
				Value (Ohms)	Multimeter scale	Value (Volts)	Multimeter scale	
Lighting generator coil	Output	YL and YL	2-MO-(A,B,C)-F and 2-MO-(A,B,C)-F	00.0 - 00.5 3 times	00.0 Ω	3.5 - 5.5 3 times	00.0 ^{Vac}	Do the test between A and B, A and C and B and C.
	Coil insulation	YL and engine	2-MO-(A,B,C)-F and engine	0.L	00.0 $M\Omega$	—	—	The term "engine" refers to the engine metal parts connected to the magneto housing.

M: Male F: Female

NOTE: It is important to take note that voltage measurements must be taken while starting the vehicle using the manual starter.

Voltages obtained upon starting are proportional to the force applied onto the manual starter. A low voltage is therefore normal under a low cranking force.

Perform testing in the prescribed order and replace any parts not performing according to specifications.

It is important to resume all tests when replacing a component.

If not specified, the probe connecting sequence is not important.

INSPECTION OF AC CIRCUIT ISOLATION

290 W Models

If AC circuit is not isolated from frame, headlamp beam will weaken.

INSPECTION

Disconnect regulator/rectifier.

Connect one digital ohmmeter probe (needle ohmmeter will not offer enough precision) to frame and other probe to YELLOW wire (2-04A).

Measured resistance must be infinite. If such is not the case, it means there is a connection between AC circuit and frame.

Disconnect one accessory at the time to identify the faulty circuit.

Section 06 ELECTRICAL

Subsection 06 (TESTING PROCEDURE)

INSPECTION OF HEATING ELEMENTS

All measurements must be performed at 21°C (70°F).

Throttle Lever Heating Element

Resistance Measurement

Formula III and Mach 1/Z Series

HIGH INTENSITY	YELLOW/BLACK wire BROWN wire	1.96 to 3.64 ohms
LOW INTENSITY	YELLOW/BLACK wire BROWN/YELLOW wire	8.05 to 14.95 ohms

Grand Touring 700/SE

YELLOW/BLACK wire BROWN wire	65 to 80 ohms
---------------------------------	---------------

Current Measurement

Formula III and Mach 1/Z Series

HIGH INTENSITY	BROWN wire	0.23 A minimum
LOW INTENSITY	BROWN/YELLOW wire	0.13 A minimum

Handlebar Grip Heating Element

Resistance Measurement

Formula III and Mach 1 Series

LOW INTENSITY	YELLOW/BLACK wire ORANGE/VIOLET wire	17.7 to ① 20.7 ohms
HIGH INTENSITY	YELLOW/BLACK wire ORANGE wire	8.73 to ① 10.67 ohms

Grand Touring 700/SE

RED/YELLOW wire ORANGE wire	6.5 to 8 ohms ①
--------------------------------	-----------------

① When measuring resistance at terminals the actual value will be half the measurement in table. The reason for that is the elements are connected in parallel. Therefore the total resistance is half the resistance of one element.