

TABLE OF CONTENTS

IGNITION TIMING	06-02-1
SINGLE CYLINDER RER CDI SYSTEM	06-02-1
TWIN CYLINDER RER CDI SYSTEM	06-02-4
DUCATI CDI SYSTEM	06-02-7
NIPPONDENSO TRIGGER COIL SYSTEM	06-02-10
<hr/>	
SPARK PLUGS	06-03-1
NGK SPARK PLUG	06-03-1
NGK SPARK PLUG NUMBERING SYSTEM	06-03-1
REFERENCE CHART	06-03-1
DESIGN SYMBOLS USED IN NGK SPARK PLUGS	06-03-2
DISASSEMBLY.....	06-03-3
HEAT RANGE.....	06-03-3
FOULING.....	06-03-3
SPARK PLUG ANALYSIS.....	06-03-3
SPARK PLUG INSTALLATION.....	06-03-4
SPARK PLUG TIGHTENING TORQUE	06-03-4
<hr/>	
BATTERY	06-04-1
REMOVAL.....	06-04-1
CLEANING	06-04-2
INSPECTION	06-04-2
HYDROMETER TEST	06-04-2
BATTERY STORAGE.....	06-04-3
ACTIVATION OF NEW BATTERY	06-04-3
SERVICING.....	06-04-5
TIPS FOR CHARGING A USED BATTERY	06-04-6
BATTERY CHARGING EQUIPMENT	06-04-7
INSTALLATION OF BATTERY	06-04-7
<hr/>	
ELECTRIC STARTER	06-05-1
REMOVAL.....	06-05-2
DISASSEMBLY.....	06-05-2
CLEANING AND INSPECTION	06-05-4
CLEANING	06-05-4
INSPECTION	06-05-4
SOLENOID SWITCH	06-05-6
ASSEMBLY.....	06-05-6
INSTALLATION	06-05-7
STARTER REMOVAL.....	06-05-9
STARTER DISASSEMBLY.....	06-05-9
CLEANING	06-05-10

Section 06 ELECTRICAL

Subsection 01 (TABLE OF CONTENTS)

PARTS INSPECTION	06-05-10
STARTER ASSEMBLY	06-05-11
STARTER INSTALLATION.....	06-05-12
<hr/>	
TESTING PROCEDURE	06-06-1
GENERAL.....	06-06-1
RER DUAL TRIGGER COIL CDI SYSTEM TESTING	06-06-6
IGNITION SYSTEM TESTING SEQUENCE	06-06-6
LIGHTING SYSTEM TESTING SEQUENCE	06-06-6
1. SPARKING	06-06-7
2. ELECTRICAL CONNECTOR TESTING	06-06-7
3. IGNITION SWITCH, TETHER CORD SWITCH AND EMERGENCY SWITCH TESTING	06-06-7
4. IGNITION GENERATOR COIL VOLTAGE TESTING	06-06-8
5. TRIGGER COIL VOLTAGE TESTING.....	06-06-8
BUZZER TESTING.....	06-06-9
MPEM CONNECTORS	06-06-9
DUCATI TRIGGER COIL CDI SYSTEM TESTING	06-06-14
IGNITION SYSTEM TESTING SEQUENCE	06-06-14
LIGHTING SYSTEM TESTING SEQUENCE	06-06-14
1. SPARKING	06-06-14
2. ELECTRICAL CONNECTOR TESTING	06-06-14
3. IGNITION SWITCH, TETHER CORD SWITCH AND EMERGENCY SWITCH TESTING	06-06-15
4. IGNITION GENERATOR COIL VOLTAGE TESTING	06-06-16
5. TRIGGER COIL VOLTAGE TESTING.....	06-06-16
CONCLUSION.....	06-06-16
LIGHTING GENERATOR COIL VOLTAGE TESTING	06-06-17
CONCLUSION.....	06-06-17
NIPPONDENSO CDI SYSTEM TESTING.....	06-06-20
IGNITION SYSTEM TESTING SEQUENCE	06-06-20
LIGHTING SYSTEM TESTING SEQUENCE	06-06-20
1. SPARKING	06-06-20
2. ELECTRICAL CONNECTOR TESTING	06-06-20
3. IGNITION SWITCH, TETHER CORD SWITCH AND EMERGENCY SWITCH TESTING	06-06-21
4. IGNITION GENERATOR COIL VOLTAGE TESTING	06-06-22
5. IGNITION MODULE VOLTAGE TESTING	06-06-22
CONCLUSION.....	06-06-22
LIGHTING GENERATOR COIL VOLTAGE TESTING	06-06-23
CONCLUSION.....	06-06-23
INSPECTION OF AC CIRCUIT ISOLATION.....	06-06-27
INSPECTION	06-06-27
INSPECTION OF HEATING ELEMENTS	06-06-28

IGNITION TIMING

SINGLE CYLINDER RER CDI SYSTEM

Tundra R 277 Engine Type

This 277 engine type is equipped with a Rotax Electronic Reverse system (RER). It uses a single coil ignition system and 2 trigger coils. Refer to CDI SYSTEM 04-06 for more informations.

This section is mainly divided in 2 parts, the first one using a Top Dead Center gauge to **verify the magneto flywheel timing mark position**. The second one using a stroboscopic timing light to **check ignition timing**.

Flywheel timing mark position verification is required to:

1. To detect a missing or broken magneto flywheel Woodruff key which would allow a change of timing to occur, with eventual break down of the engine.
2. To correctly locate and mark a timing mark on a new service magneto flywheel.
3. To verify the correct location of the factory timing mark.
4. To detect a wrong magneto flywheel corresponding to a different engine type.

Always verify magneto flywheel timing mark position before checking ignition timing.

Verifying Magneto Flywheel Timing Mark Position

1. Disconnect spark plug wire and remove spark plug.
2. Install and adjust TDC gauge on engine as follows:
 - Rotate magneto flywheel clockwise until piston is just Before Top Dead Center.

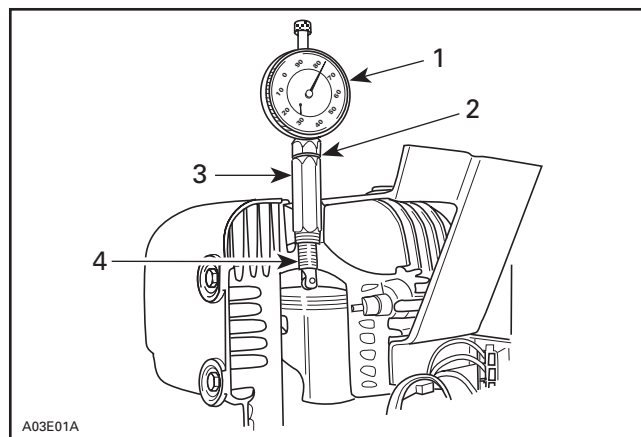

- A03E01A
1. Outer ring
 2. Adaptor lock nut
 3. Roller lock nut
 4. Adaptor

- Loosen adaptor lock nut then holding gauge with dial face toward magneto, screw adaptor in spark plug hole.
 - Slide gauge far enough into adaptor to obtain a reading then finger tighten adaptor lock nut.
 - Rotate magneto flywheel clockwise until piston is at Top Dead Center.
 - Unlock outer ring of dial and turn it until "0" (zero) on dial aligns with pointer.
 - Lock outer ring in position.
3. From this point, rotate magneto flywheel back 1/4 turn then rotate it clockwise to reach the specified position. Refer to TECHNICAL DATA 10.

Section 06 ELECTRICAL

Subsection 02 (IGNITION TIMING)

Check if red fin aligns with mark on fan cowl.

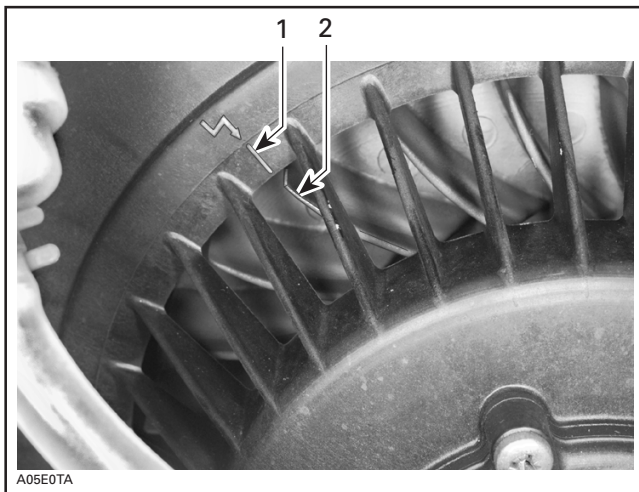

1. Fan cowl timing mark
2. Red fin

If marks do not align, there is something wrong with fan mounting. Check Woodruff key and fan.

CAUTION: Always check the timing with a stroboscopic timing light at 3500 RPM after the marks have been checked.

Checking Ignition Timing

NOTE: To perform this procedure we strongly recommend a stroboscopic timing light which is able to exceed 3500 RPM.

To check ignition timing, use a timing light (P/N 529 031 900).

NOTE: This timing light is battery powered (2 alkaline batteries, type C) and therefore needs no auxiliary power supply. If a different timing light requiring auxiliary power supply is used on manual start models, use a separate battery to power timing light.



TIMING LIGHT (P/N 529 031 900)

1. Connect timing light pick-up to the spark plug lead. Use a digital induction type tachometer (P/N 529 014 500).

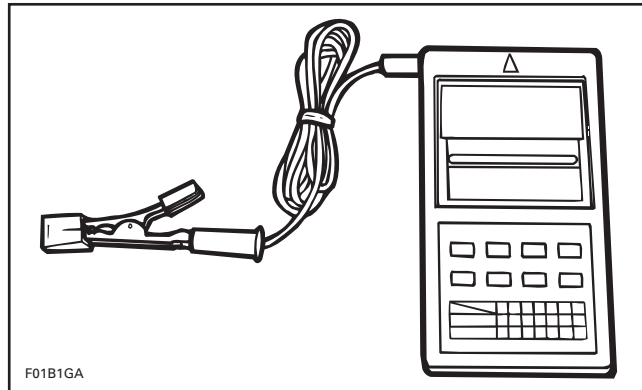

TACHOMETER (P/N 529 014 500)

Connect tachometer wire to spark plug wire or aim tachometer toward spark plug wire without using any connection wire.

WARNING

Place ski tips against a wall, raise rear of vehicle on a stand so that track does not contact the ground. Do not allow anyone in front or behind the vehicle while engine is running. Keep clear of track and do not wear loose clothing which can get caught in moving parts.

2. Start the engine and point timing light straight in line with the fan cowl timing mark. Bring engine to 3500 RPM (3000 to 4000 RPM) for a brief instant.

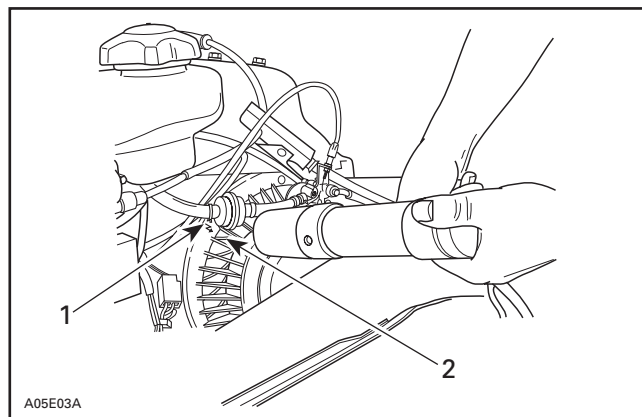

TYPICAL — TUNDRA R

1. Fan cowl timing mark
2. Red fin

3. Check if the red fin aligns with the fan cowl timing mark. Tolerance is 1°.

If the red fin aligns with the fan cowl timing mark, timing is correct. If not the case, check for proper flywheel, trigger coil position or MPEM.

The RER ignition system is not adjustable. Only trigger coil air gap can be verified. Refer to CDI SYSTEM 04-06.

Section 06 ELECTRICAL

Subsection 02 (IGNITION TIMING)

TWIN CYLINDER RER CDI SYSTEM

377, 443 and 503 Engine Types on Skandic 380/500, Touring E/LE/SLE and Formula DLX 380/500

If for any reason, ignition timing accuracy is suspected, it can be verified as follows.

Verifying Magneto Flywheel Timing Mark Position

Prior to checking the timing, it may be necessary to verify the position of the timing mark on the magneto flywheel, for the following reasons:

1. To detect a missing or broken magneto flywheel Woodruff key which would allow a change of timing to occur, with eventual break down of the engine.
2. To correctly locate and mark a timing mark on a new service magneto flywheel.
3. To verify the correct location of the factory timing mark.
4. To detect a wrong magneto flywheel corresponding to a different engine type.

To verify the position of the timing mark on the magneto flywheel, proceed as follows:

1. Clean the area around the spark plugs, and remove them.
2. Remove the rewind starter from the engine.
3. Install the TDC gauge in the spark plug hole, (magneto/generator side) and adjust as follows:
 - a. Position the magneto flywheel at approximately TDC.

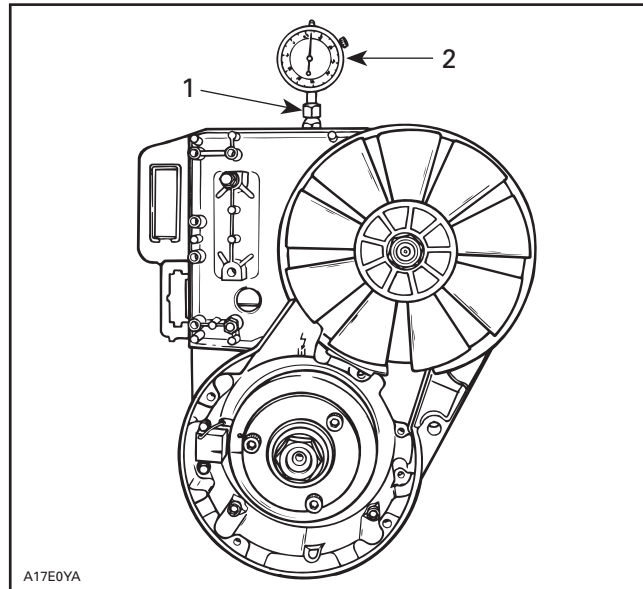

TYPICAL — INSTALLATION OF TDC GAUGE

1. Gauge on MAG side cylinder
2. Adaptor lock nut

- b. Assemble the gauge to the adaptor and tighten the roller lock nut. Do not tighten the adaptor lock nut.
 - c. Screw the adaptor into the spark plug hole and tighten to prevent movement in the plug hole.
 - d. Position the dial face toward the magneto/generator. Move the gauge down until the needle just begins to move, then move down a further 5 or 6 mm (approximately 1/4 in). Tighten adaptor lock nut by hand.
4. Locate the piston TDC position as follows:
 - a. Slowly rotate the magneto flywheel back and forth across TDC while observing the needle. Note that the needle stops moving only as the piston is changing direction.
 - b. Rotate the dial face so that "0" is in line with the needle when it stops moving.
 - c. Again, slowly rotate the magneto flywheel back and forth across TDC and adjust the dial face to "0", until the needle always stops exactly at "0" before changing direction.
 - d. "0" now indicates exact TDC.

Section 06 ELECTRICAL

Subsection 02 (IGNITION TIMING)

5. Verify the position of the timing mark on the magneto flywheel as follows:

NOTE: When checking timing, certain procedures require that the magneto flywheel be turned in a clockwise direction, viewed facing the magneto/generator. If it is necessary to turn back (counterclockwise) for any reason, rotate the magneto flywheel at least one-quarter turn counterclockwise, and then rotate it clockwise. The last magneto flywheel movement when making a critical check must always be in a clockwise direction, to ensure that the slack in engine moving parts is taken-up.

- Rotate the magneto flywheel counterclockwise, one-quarter turn then carefully rotate it clockwise until the needle indicates the specified measurement. Refer to TECHNICAL DATA 10.
- Verify that the magneto flywheel mark perfectly aligns with the mark on the trigger coil, refer to illustration.
- If the marks do not align, check magneto flywheel and trigger coil part numbers and check Woodruff key condition. If all parts are the appropriate ones and if Woodruff key is in good condition, continue the procedure.

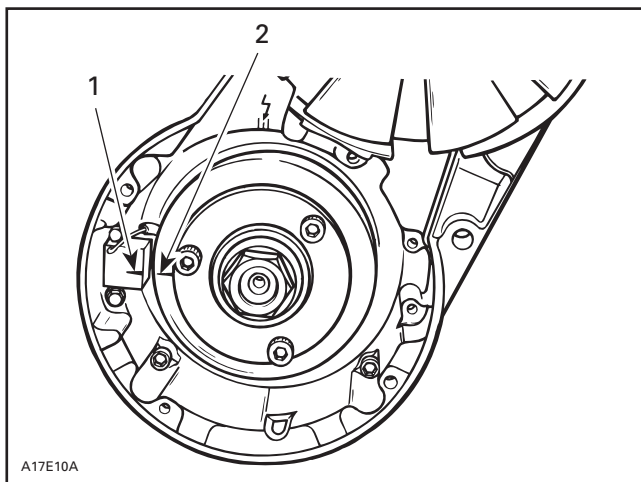

TYPICAL

- Trigger coil mark
- Magneto flywheel mark

NOTE: These marks cannot be used to check dynamic (with engine running) ignition timing with a timing light: a new mark must be scribed on magneto flywheel for this purpose.

6. Scribe a new mark on magneto flywheel as follows.

- Remove the fan cover from the engine.
- Maintain magneto flywheel so that previous marks remain aligned.
- Scribe or punch a mark on magneto flywheel so that it perfectly aligns with the arrow on crankcase, refer to illustration. This new timing mark should be used for future timing checks (dynamic timing).
- Reinstall rewind starter.
- Check the timing with a timing light.

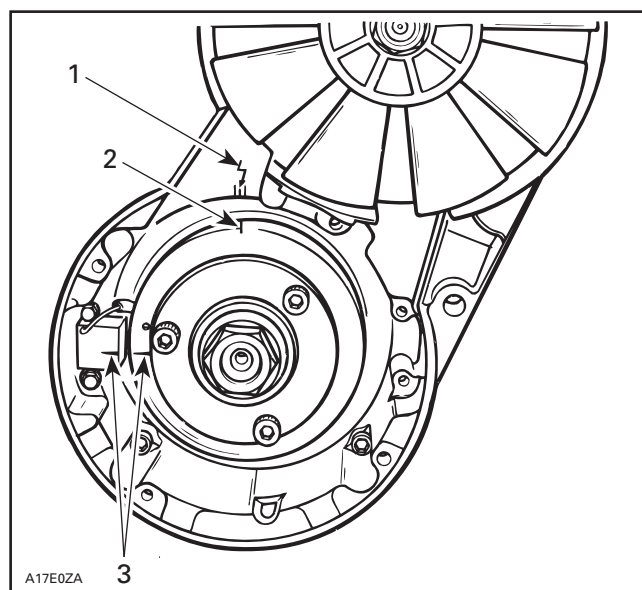

TYPICAL

- Crankcase arrow
- Scribe a mark here
- Maintain verified timing marks aligned (static timing)

Checking Ignition Timing

Use timing light (P/N 529 031 900).



TIMING LIGHT (P/N 529 031 900)

Section 06 ELECTRICAL

Subsection 02 (IGNITION TIMING)

To check the ignition timing, refer to illustration and proceed as follows:

⚠ WARNING

Place ski tips against a wall, raise rear of vehicle on a stand, so that track does not contact the ground. Do not allow anyone in front of or behind the vehicle while engine is running. Keep clear of track and do not wear loose clothing which can get caught in moving parts.

1. Connect the timing light pick-up to a spark plug cable and the power connections to the battery.

NOTE: To avoid an incorrect reading due to parallax, view the magneto flywheel and the crankcase timing marks in a straight line.

2. Start the engine and raise the engine speed at least to 3500 RPM (3000 to 4000 RPM) while observing the timing marks, refer to illustration. The magneto flywheel mark scribed previously and the crankcase arrow should be perfectly aligned. If the marks do not align, a faulty trigger coil (check proper grounding of coil) or a faulty CDI module could be the cause: substitute one part at a time and recheck timing marks (check connectors condition prior to substituting any part).

NOTE: Ignition timing may be verified when engine speed is anywhere within 3000-4000 RPM.

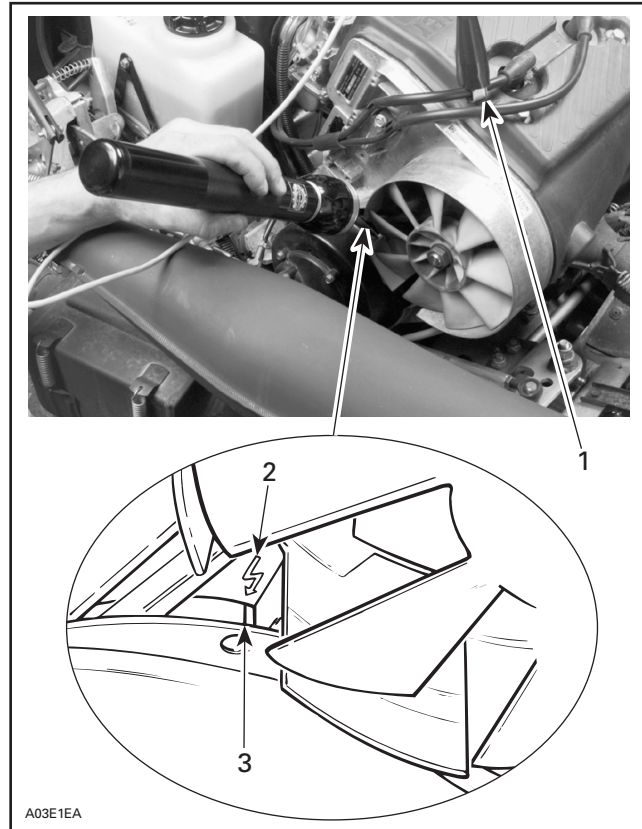

S-SERIES

1. Timing light pick-up on MAG side
2. Crankcase arrow
3. Magneto flywheel mark

3. Install parts which were removed.

DUCATI CDI SYSTEM

377, 443 and 503 Engine Types on Skandic WT/SWT, Formula S and MX Z 440

Proper ignition timing is determined by trigger coil position.

If for any reason, ignition timing accuracy is suspected, it can be checked as follows.

Verifying Magneto Flywheel Timing Mark Position

Prior to checking the timing, it may be necessary to verify the position of the timing mark on the magneto flywheel, for the following reasons:

1. To detect a missing or broken magneto flywheel Woodruff key which would allow a change of timing to occur, with eventual break down of the engine.
2. To correctly locate and mark a timing mark on a new service magneto flywheel.
3. To verify the correct location of the factory timing mark.
4. To detect a wrong magneto flywheel.

To verify the position of the timing mark on the magneto flywheel, proceed as follows:

1. Clean the area around the spark plugs, and remove them.
2. Remove the rewind starter from the engine.
3. Install the TDC gauge in the spark plug hole, (magneto/generator side) and adjust as follows:
 - a. Position the magneto flywheel at approximately TDC.

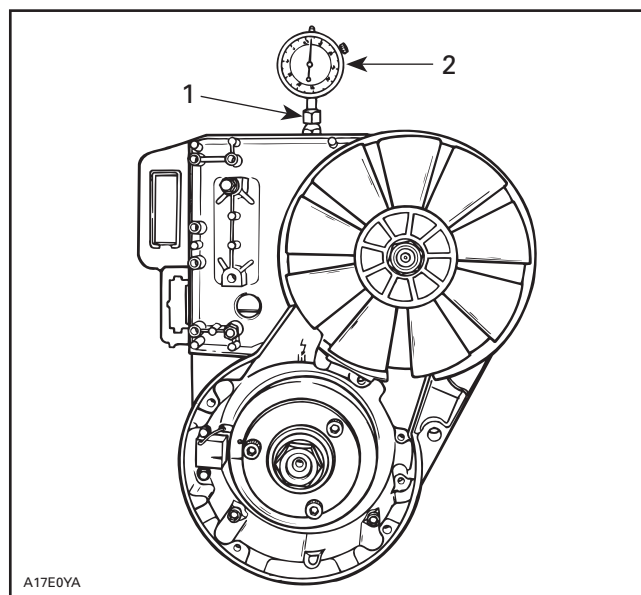

INSTALLATION OF TDC GAUGE

1. Adapter lock nut
 2. Gauge on MAG side cylinder
- a. Assemble the gauge to the adapter and tighten the roller lock nut. Do not tighten the adapter lock nut.
 - b. Screw the adapter into the spark plug hole and tighten to prevent movement in the plug hole.
 - c. Position the dial face toward the magneto/generator. Move the gauge down until the needle just begins to move, then move down a further 5 or 6 mm (approximately 1/4 in). Tighten adapter lock nut by hand.
4. Locate the piston TDC position as follows:
 - a. Slowly rotate the magneto flywheel back and forth across TDC while observing the needle. Note that the needle stops moving only as the piston is changing direction.
 - b. Rotate the dial face so that 0 (zero) is in line with the needle when it stops moving.
 - c. Again, slowly rotate the magneto flywheel back and forth across TDC and adjust the dial face to 0 (zero), until the needle always stops exactly at 0 (zero) before changing direction.
 - d. 0 (zero) now indicates exact TDC.

Section 06 ELECTRICAL

Subsection 02 (IGNITION TIMING)

5. Verify the position of the timing mark on the magneto flywheel as follows:

NOTE: When checking timing, certain procedures require that the magneto flywheel be turned in a clockwise direction, viewed facing the magneto/generator. If it is necessary to turn back (counterclockwise) for any reason, rotate the magneto flywheel at least 1/4 turn counterclockwise, and then rotate it clockwise. The last magneto flywheel movement when making a critical check must always be in a clockwise direction, to ensure that the slack in engine moving parts is taken-up.

- Rotate the magneto flywheel 1/4 turn counterclockwise, 1/4 turn then carefully rotate it clockwise until the needle indicates the specified measurement. Refer to TECHNICAL DATA 10.
- Verify that the magneto flywheel mark perfectly aligns with the mark on the trigger coil, refer to illustration.
- If the marks do not align, check magneto flywheel and trigger coil part numbers and check Woodruff key condition. If all parts are the appropriate ones and if Woodruff key is in good condition, continue the procedure.

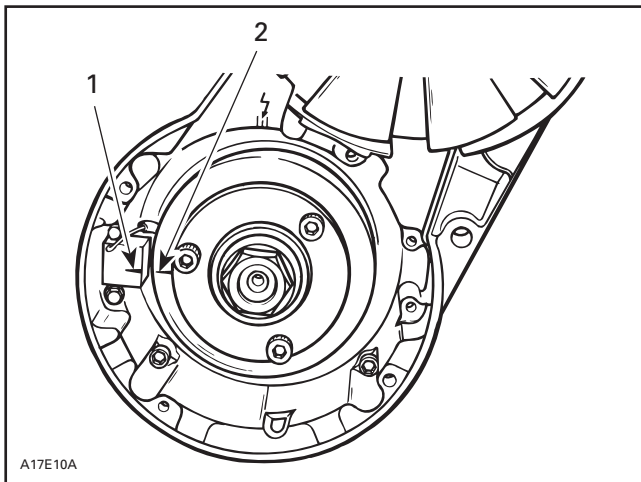

1. Trigger coil mark
2. Magneto flywheel mark

NOTE: These marks cannot be used to check dynamic (with engine running) ignition timing with a timing light: a new mark must be scribed on magneto flywheel for this purpose.

6. Scribe a new mark on magneto flywheel as follows:
 - Remove the fan cover from the engine.
 - Maintain magneto flywheel so that previous marks remain aligned.
 - Scribe or punch a mark on magneto flywheel so that it aligns perfectly with the arrow on crankcase, refer to illustration. This new timing mark should be used for future timing checks (dynamic timing).
 - Reinstall rewind starter.
 - Check the timing with a timing light (P/N 529 031 900).

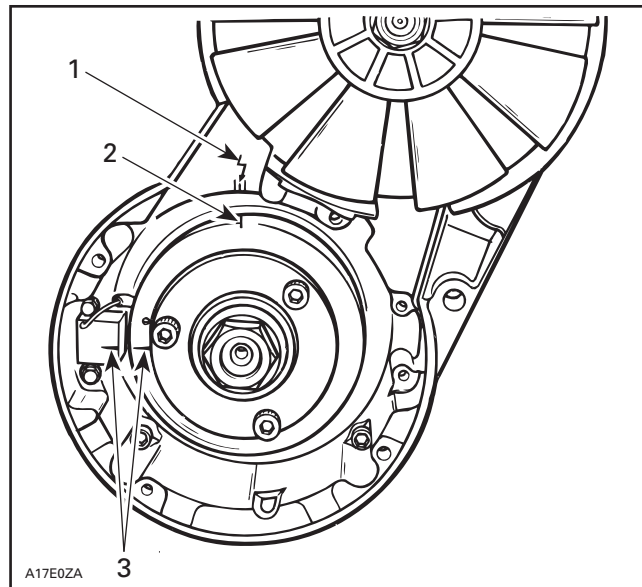

1. Crankcase arrow
2. Scribe a mark here
3. Maintain verified timing marks aligned (static timing)

Checking Ignition Timing

Use timing light (P/N 529 031 900).

To check the ignition timing, refer to illustration and proceed as follows:

NOTE: Engine should be cold when checking timing. Do not idle engine for more than 20 seconds and make checks quickly.

WARNING

Place ski tips against a wall, raise rear of vehicle on a stand, so that track does not contact the ground. Do not allow anyone in front of or behind the vehicle while engine is running. Keep clear of track and do not wear loose clothing which can get caught in moving parts.

1. Connect the timing light pick-up to a spark plug cable and the power connections to the battery.

NOTE: To avoid an incorrect reading due to parallax, view the magneto flywheel and the crankcase timing marks in a straight line.

2. Start the engine and raise the engine speed to 6000 RPM while observing the timing marks, refer to illustration. The magneto flywheel mark scribed previously and the crankcase arrow should be perfectly aligned. If the marks do not align, a faulty trigger coil (check proper grounding of coil) or a faulty CDI module could be the cause: substitute one part at a time and recheck timing marks (check connectors condition prior to substituting any part).

NOTE: Ignition timing have to be verified when engine speed is 6000 RPM.

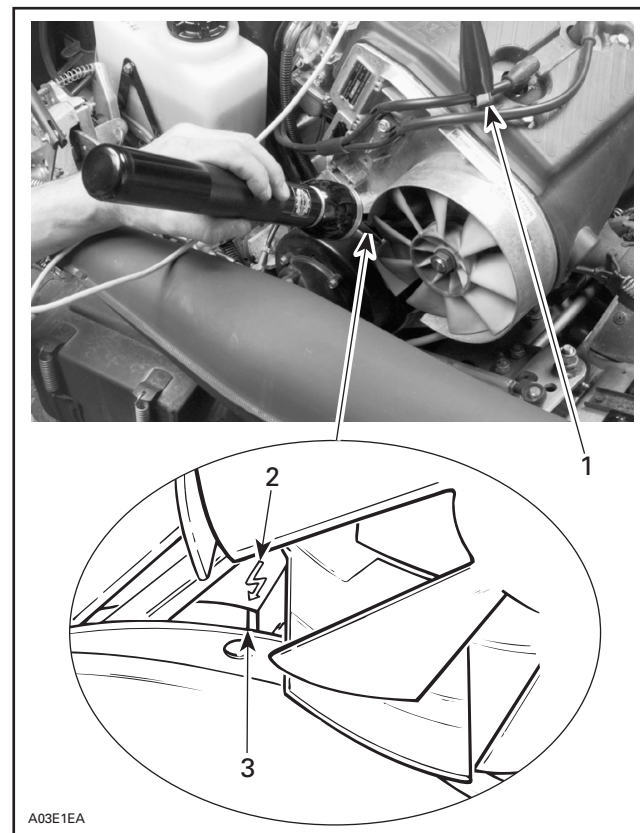

CHECKING IGNITION TIMING

1. Timing light pick-up on MAG side
2. Crankcase arrow
3. Magneto flywheel mark

3. Install parts which were removed.

Section 06 ELECTRICAL

Subsection 02 (IGNITION TIMING)

NIPPONDENSO TRIGGER COIL SYSTEM

494 Engine Type

Ignition timing is adjusted by movement of trigger coil. Moving trigger coil to right retards ignition and moving to left advances ignition.

CAUTION: Each time ignition timing is adjusted by moving trigger coil, air gap must be adjusted.

Verifying Magneto Flywheel Timing Mark Position

Prior to checking the timing, it may be necessary to verify the position of the timing mark on the magneto flywheel, for the following reasons:

1. To detect a missing or broken magneto flywheel Woodruff key which would allow a change of timing to occur, with eventual break down of the engine.
2. To correctly locate and mark a timing mark on a new service magneto flywheel.
3. To verify the correct location of the factory timing mark.
4. To detect a wrong magneto flywheel.

To verify the position of the timing mark on the magneto flywheel or to scribe a timing mark, proceed as follows:

1. Clean the area around the spark plugs, and remove them.
2. Remove the rewind starter from the engine.
3. Install the TDC gauge in the spark plug hole (magneto side) and adjust as follows:
 - a. Position the magneto flywheel at approximately TDC.

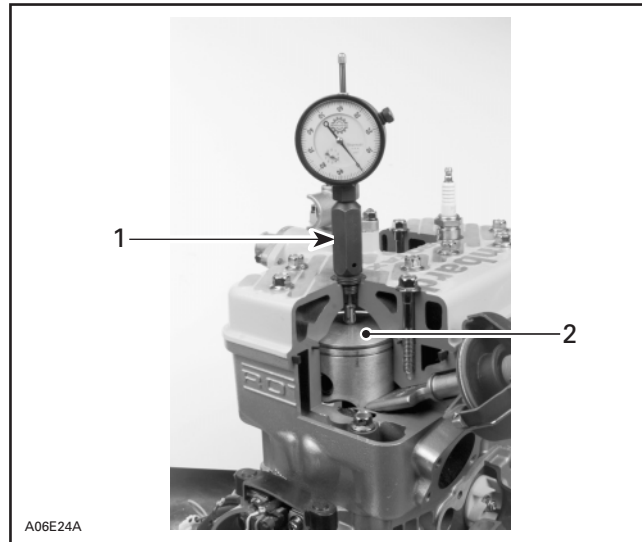

A06E24A

TYPICAL

1. TDC gauge on MAG side
2. MAG side piston at TDC

- b. Assemble the gauge to the adapter and tighten the roller lock nut. Do not tighten the adapter lock nut.
 - c. Screw the adapter into the spark plug hole and tighten to prevent movement in the plug hole.
 - d. Position the dial face toward the magneto. Move the gauge down until the needle just begins to move, then move down a further 5 or 6 mm (approximately 1/4 in). Tighten adapter lock nut by hand.
4. Locate the piston TDC position as follows:
 - a. Slowly rotate the magneto flywheel back and forth across TDC while observing the needle. Note that the needle stops moving only as the piston is changing direction.
 - b. Rotate the dial face so that 0 (zero) is in line with the needle when it stops moving.
 - c. Again, slowly rotate the magneto flywheel back and forth across TDC and adjust the dial face to 0 (zero), until the needle always stops exactly at 0 (zero) before changing direction.
 - d. 0 (zero) now indicates exact TDC.

Section 06 ELECTRICAL

Subsection 02 (IGNITION TIMING)

5. Verify the position of the timing mark on the magneto flywheel as follows:

NOTE: When checking timing, certain procedures require that the magneto flywheel be turned in a clockwise direction, viewed facing the magneto. If it is necessary to turn back (counterclockwise) for any reason, rotate the magneto flywheel at least 1/4 turn counterclockwise, and then rotate it clockwise. The last magneto flywheel movement when making a critical check must always be in a clockwise direction, to ensure that the slack in engine moving parts is taken-up.

- Rotate the magneto flywheel 1/4 turn counterclockwise, 1/4 turn then carefully rotate it clockwise until the needle indicates the specified measurement, indicated in TECHNICAL DATA 10.
- Make sure that the dot located on the side of the magneto flywheel protrusion perfectly aligns with center of trigger coil core, refer to illustration.
- If the marks do not align, loosen trigger coil screws and move trigger coil to align dot with center of trigger coil core.

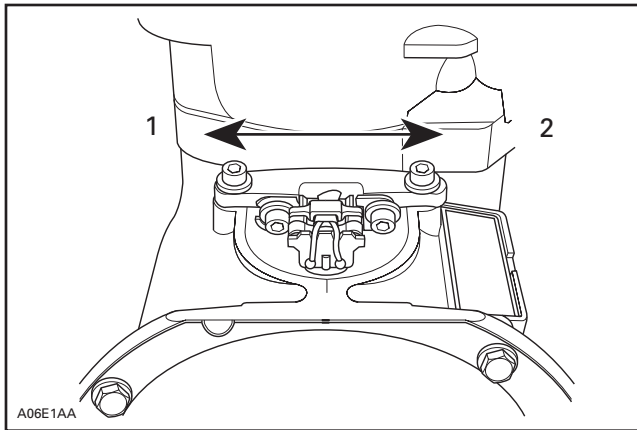

- Advance
- Retard

- Using a feeler gauge of 0.75 mm (.030 in) (allowable range is 0.55 mm (.022 in) to 1.45 mm (.057 in)), check air gap between center pole of trigger coil and flywheel protrusion.

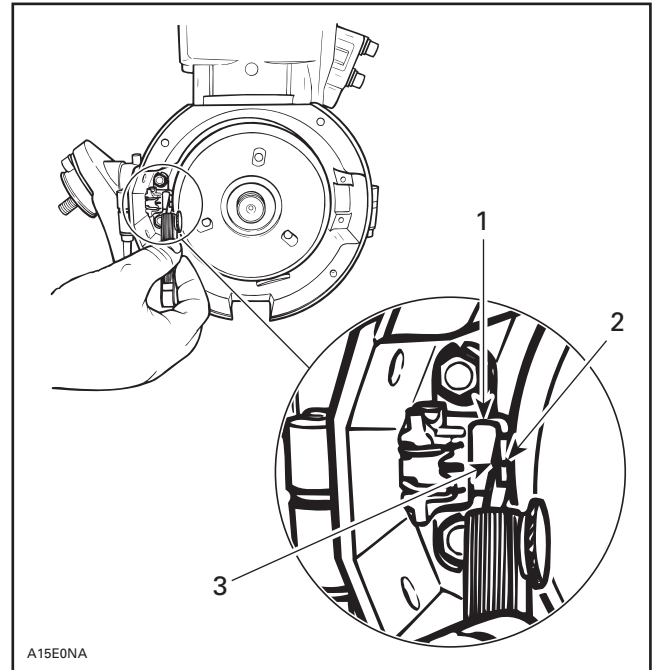

TYPICAL — TRIGGER COIL AIR GAP ADJUSTMENT

- Trigger coil
- Flywheel protrusion
- Measure at center pole of trigger coil 0.75 mm (.030 in)

NOTE: These marks cannot be used to check dynamic (with engine running) ignition timing with a timing light: another mark is scribed on magneto flywheel or damper for this purpose. When flywheel protrusion dot aligns with center of trigger coil core, flywheel mark and crankcase center mark must be aligned.

Checking Ignition Timing

Use timing light (P/N 529 031 900).

To check the ignition timing, refer to illustration and proceed as follows:

Engine should be cold when checking timing. Do not let engine idle for more than 20 seconds and make checks quickly.

⚠ WARNING

Place ski tips against a wall, raise rear of vehicle on a stand, so that track does not contact the ground. Do not allow anyone in front of or behind the vehicle while engine is running. Keep clear of track and do not wear loose clothing which can get caught in moving parts.

Section 06 ELECTRICAL

Subsection 02 (IGNITION TIMING)

1. Connect the timing light pick-up to a spark plug cable and the power connections to the battery.

NOTE: To avoid an incorrect reading due to parallax, view the magneto flywheel and the crankcase timing marks in a straight line.

2. Start the engine and point timing light straight in line with the crankcase timing mark.

Bring engine to 6 000 RPM for a brief instant.

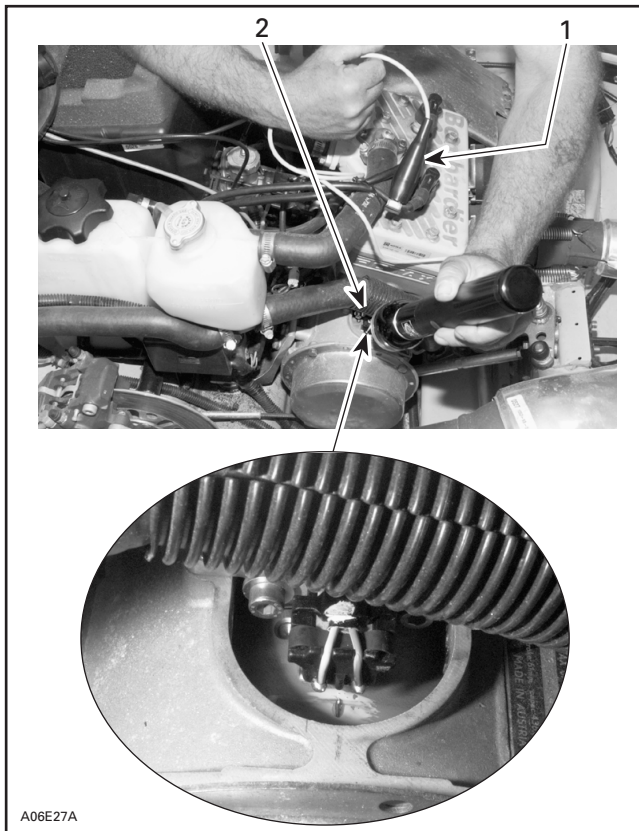

TYPICAL

1. Timing light pick-up on MAG side
2. Timing inspection hole

The magneto/damper mark must be aligned with center mark. If not, move trigger coil as explained above and recheck ignition timing. Tolerance is $\pm 1^\circ$.

If the marks still do not align, a faulty trigger coil (check proper grounding of coil) or a faulty CDI module could be the cause: substitute one part at a time and recheck timing marks (check connectors condition prior to substituting any part).

SPARK PLUGS

NGK SPARK PLUG

All Models

NGK SPARK PLUG NUMBERING SYSTEM

Bombardier uses NGK brand spark plugs on all its snowmobile models.

The heat range identification system is:

Low number  hot plug

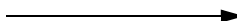
High number  cold plug

REFERENCE CHART

NGK spark plugs used on Bombardier snowmobiles are covered in this manual:

- BR9ES

Section 06 ELECTRICAL

Subsection 03 (SPARK PLUGS)

DESIGN SYMBOLS USED IN NGK SPARK PLUGS

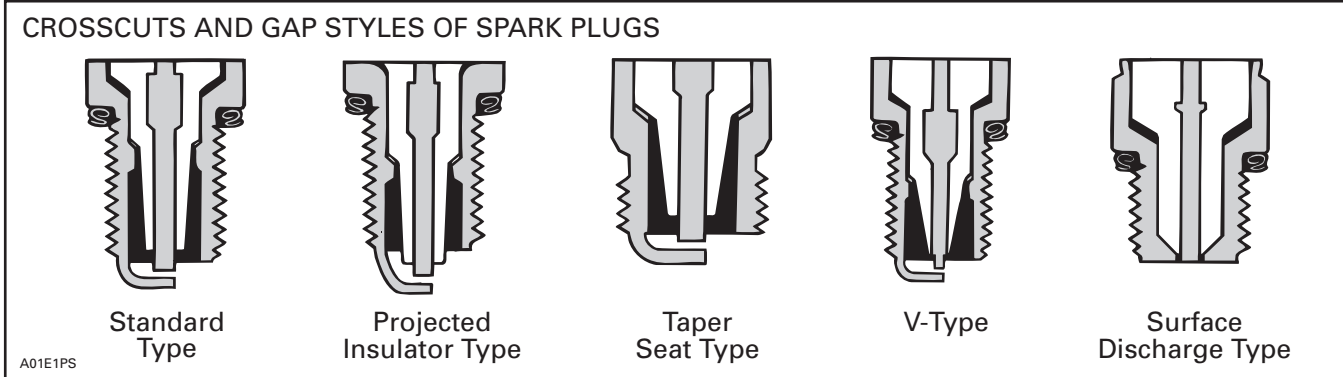
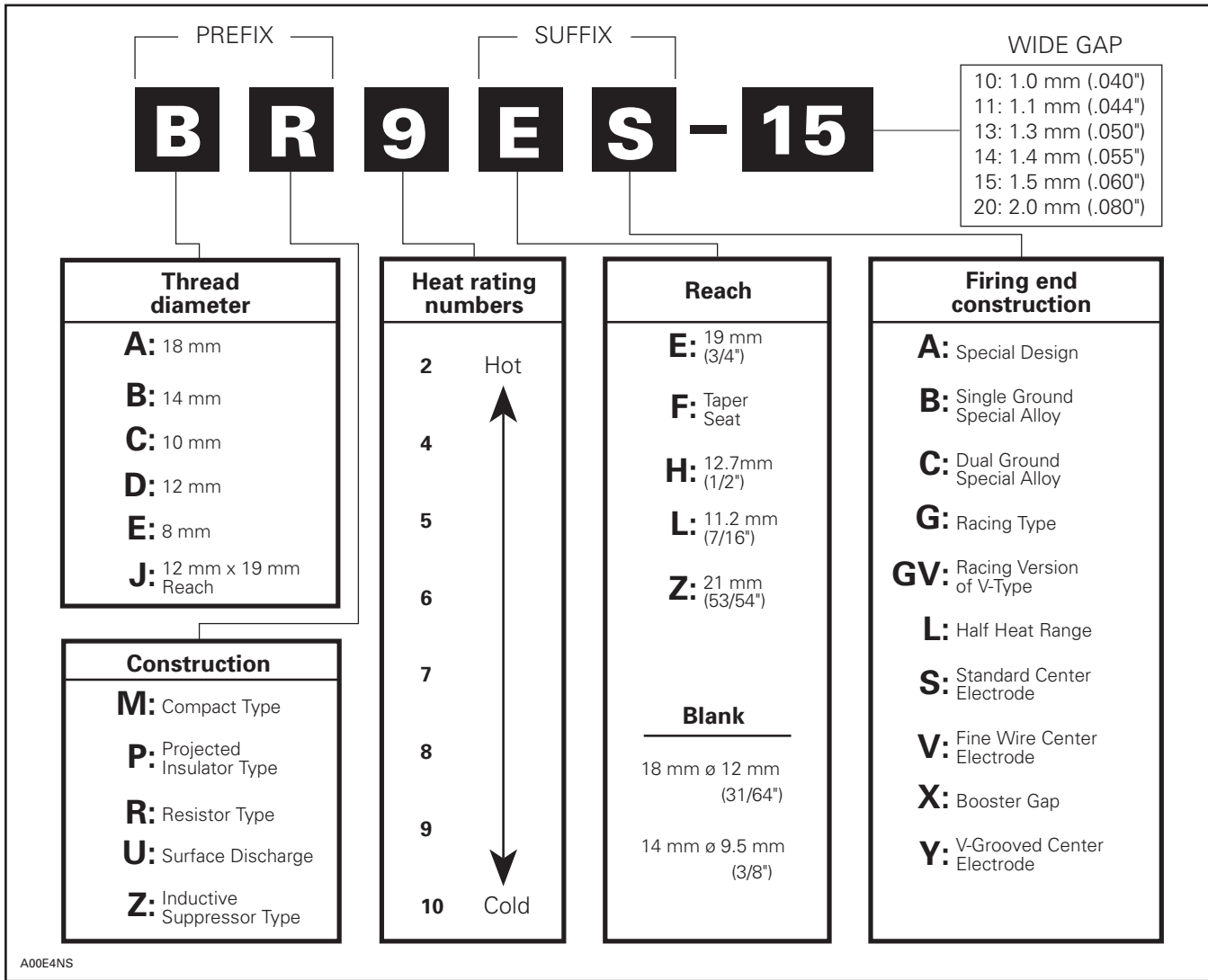

DISASSEMBLY

First unscrew the spark plug 1 turn.

Clean the spark plug and cylinder head with pressurized air, then completely unscrew.

WARNING

Whenever using compressed air, always wear protective eye wear.

HEAT RANGE

The proper operating temperature or heat range of the spark plugs is determined by the spark plug ability to dissipate the heat generated by combustion.

The longer the heat path between the electrode tip to the plug shell, the hotter the spark plug operating temperature will be — and inversely, the shorter the heat path, the colder the operating temperature will be.

A **cold** type plug has a relatively short insulator nose and transfers heat very rapidly into the cylinder head.

Such a plug is used in heavy duty or continuous high speed operation to avoid overheating.

The **hot** type plug has a longer insulator nose and transfers heat more slowly away from its firing end. It runs hotter and burns off combustion deposits which might tend to foul the plug during prolonged idle or low speed operation.

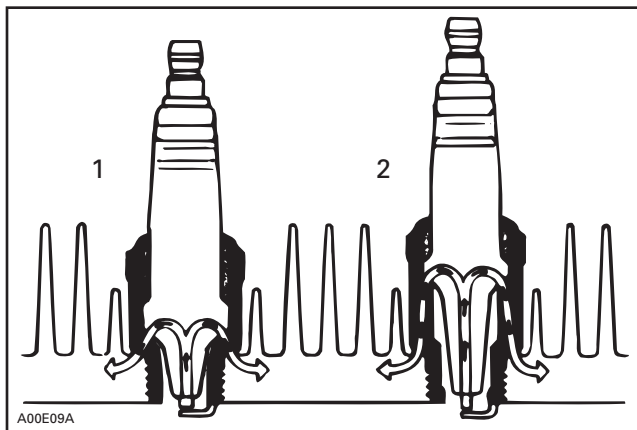

1. Cold
2. Hot

CAUTION: Severe engine damage might occur if a wrong heat range plug is used.

A **too hot** plug will result in overheating and pre-ignition, etc.

A **too cold** plug will result in fouling (shorting the spark plug) or may create carbon build up which can heat up red-hot and cause pre-ignition or detonation.

FOULING

Fouling of the spark plug is indicated by irregular running of the engine, decreased engine speed due to misfiring, reduced performance, and increased fuel consumption. This is due to a loss of compression. Other possible causes are: prolonged idling, or running on a too rich mixture due to a faulty carburetor adjustment or incorrect fuel and/or fuel mixing. The plug face of a fouled spark plug has either a dry coating of soot or an oily, glossy coating given by an excess either of oil or of oil with soot. Such coatings form a conductive connection between the center electrode and ground.

SPARK PLUG ANALYSIS

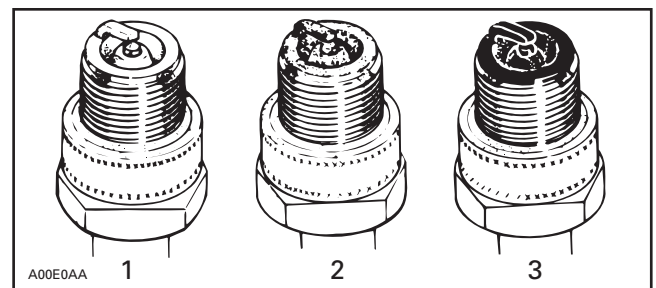

1. Overheated (light grey)
2. Normal (brownish)
3. Fouled (black)

The plug electrode and piston dome reveal the condition of the engine, operating condition, method of driving and fuel mixture. For this reason it is advisable to inspect the spark plug at regular intervals, examining the plug electrode and the piston dome.

Section 06 ELECTRICAL

Subsection 03 (SPARK PLUGS)

SPARK PLUG INSTALLATION

Prior to installation make sure that contact surfaces of the cylinder head and spark plug are free of grime.

1. Using a wire feeler gauge, set electrode gap according to TECHNICAL DATA 10.
2. Apply anti-seize lubricant (P/N 413 701 000) over the spark plug threads to prevent possible seizure.
3. Hand screw spark plug into cylinder head and tighten with a torque wrench and a proper socket.

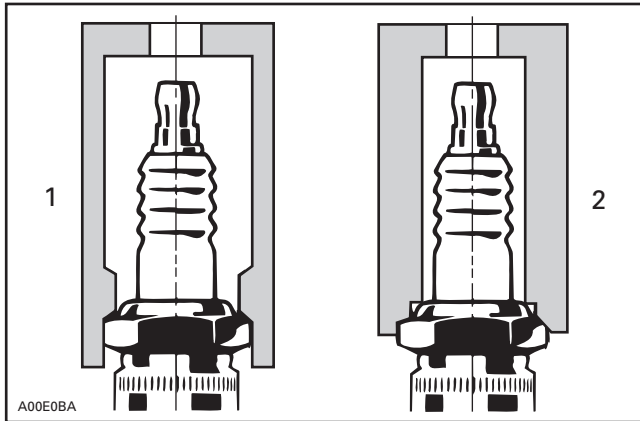

1. Proper socket
2. Improper socket

SPARK PLUG TIGHTENING TORQUE

MODELS	SPARK PLUGS	TORQUE N•m (lbf•ft)
All models	NGK	27 (20)

BATTERY

REMOVAL

All Models

WARNING

Battery BLACK negative cable must always be disconnected first and connected last.

WARNING

Never charge or boost battery while installed on vehicle.

S-Series

Remove guard.

Fan Cooled S-Series

Unfasten spark plug cables from fan housing. Unplug spark plug caps.

Remove throttle cable attachment from air silencer.

Unplug CDI box harness connector.

Loosen collar on carburetor adaptors. Remove air silencer. CDI box will come along with.

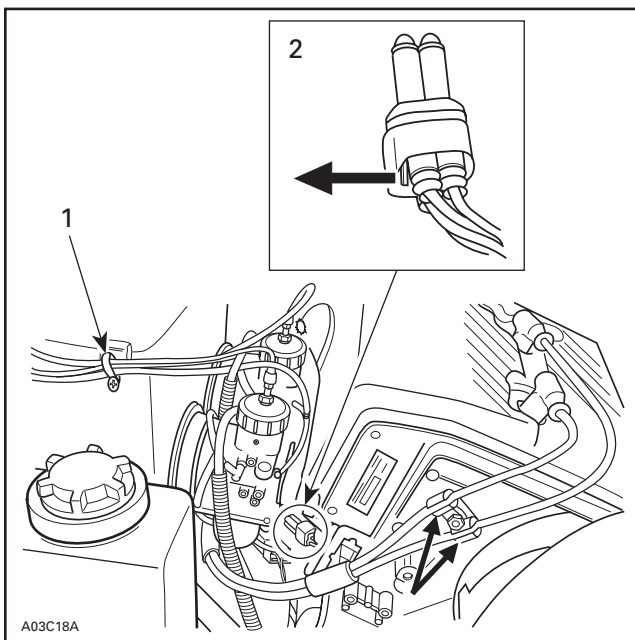

1. Attachment
2. CDI box harness connector

Liquid Cooled S-Series

Remove air silencer.

S-Series

Unfasten retaining strips.

Open strips and lift battery protective boot.

Remove vent tube.

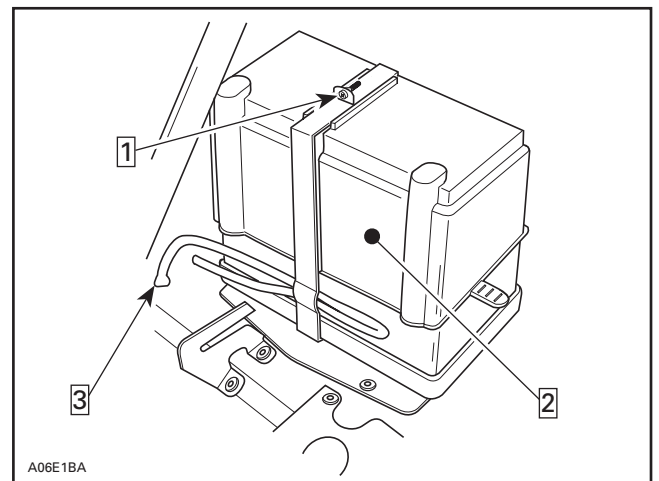

- Step **1**: Unfasten and open
Step **2**: Lift protective boot
Step **3**: Remove vent tube

All Models

Withdraw battery from vehicle being careful not lean it so that electrolyte flows out of vent tube.

CAUTION: Should any electrolyte spillage occur, immediately wash off with a solution of baking soda and water to prevent damage to vehicle components.

Section 06 ELECTRICAL

Subsection 04 (BATTERY)

CLEANING

Clean the battery, battery casing, vent tube, caps, cables and battery posts using a solution of baking soda and water.

CAUTION: Do not allow cleaning solution to enter battery interior since it will destroy the electrolyte.

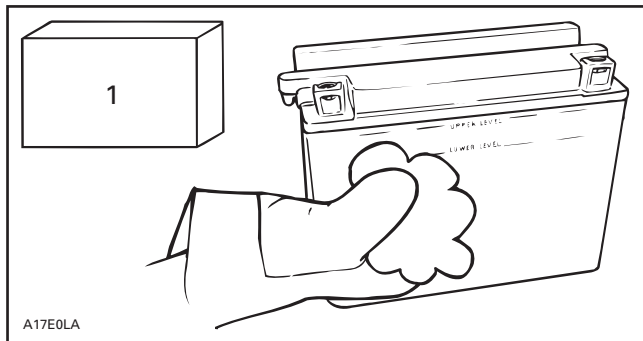

1. Baking soda

Remove corrosion from battery cable terminals and battery posts using a firm wire brush.

INSPECTION

Visually inspect battery casing for cracks or other possible damage. If casing is damaged, replace battery and thoroughly clean battery tray and close area with water and baking soda.

⚠ WARNING

Should the battery casing be damaged, wear a suitable pair of non-absorbent gloves when removing the battery by hand.

Inspect battery posts for security of mounting.

Inspect for cracked or damaged battery caps, replace defective caps.

⚠ WARNING

Battery caps do not have vent holes. Make sure that vent tube is not obstructed.

HYDROMETER TEST

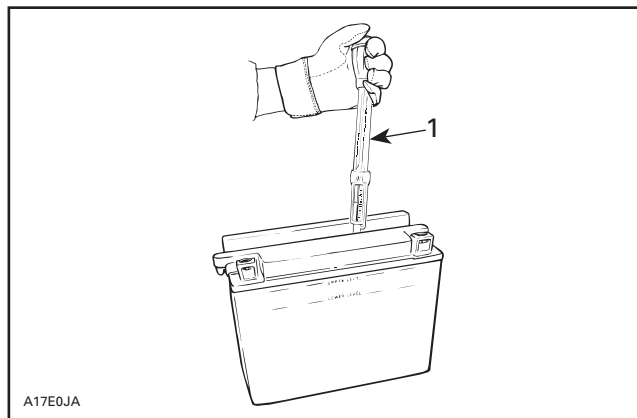

1. Specific gravity 1.260

A hydrometer measures the charge of a battery in terms of specific gravity of the electrolyte. Most hydrometers give a true reading at 27°C (80°F).

In order to obtain correct readings, adjust the initial reading by **adding** .004 points to the hydrometer readings for each 5.5°C (10°F) **above 27°C (80°F)** and by **subtracting** .004 point for every 5.5°C (10°F) **below 27°C (80°F)**.

This chart will be useful to find the correct reading.

ELECTROLYTE TEMPERATURE		OPERATION TO PERFORM		
°C	°F			
38	100	add	.008 to the reading	
32	90			.004
27	80	correct reading		
21	70	subtract	.004 from the reading	
16	60			.008
10	50			.012
4	40			.016
-1	30			.020
-7	20			.024
-12	10			.028
-18	0			.032
-23	-10			.036
-29	-20			.040
-34	-30			.044
-40	-40			.048

EXAMPLE NO. 1

Temperature below 27°C (80°F):
 Hydrometer Reading: 1.250
 Electrolyte temperature: - 7°C (20°F)
 Subtract .024 Sp. Gr.
 Corrected Sp. Gr. is 1.226

EXAMPLE NO. 2

Temperature above 27°C (80°F):
 Hydrometer Reading: 1.235
 Electrolyte temperature: 38°C (100°F)
 Add .008 Sp. Gr.
 Corrected Sp. Gr. is 1.243

CAUTION: Do not install a partially charged battery on a snowmobile since the casing might crack at freezing temperature. The following chart shows the freezing point of the electrolyte in relation to the charge of the battery.

TEMPERATURE CORRECTED SPECIFIC GRAVITY	BATTERY CHARGE	FREEZING POINT OF ELECTROLYTE
1.260	Fully charged	- 59°C (- 74°F)
1.230	3/4 charged	- 40°C (- 40°F)
1.200	1/2 charged	- 27°C (- 16°F)
1.170	1/4 charged	- 18°C (0°F)
1.110	Discharged	- 7°C (+ 19°F)

BATTERY STORAGE

Disconnect and remove battery from the vehicle. Check electrolyte level in each cell, add distilled water up to upper level line.

CAUTION: Do not overfill.

The battery must always be stored in fully charged condition. If required, charge until specific gravity of 1.260 is obtained.

CAUTION: Battery electrolyte temperature must not exceed 50°C (122°F). The casing should not feel hot.

Clean battery terminals and cable connections using a wire brush. Apply a light coat of dielectric grease (P/N 413 701 700) or petroleum jelly on terminals.

Clean battery casing and caps using a solution of baking soda and water. Do not allow cleaning solution to enter battery, otherwise it will destroy the electrolyte. Rinse battery with clear water and dry well using a clean cloth.

Store battery on a wooden shelf in a cool dry place. Such conditions reduce self-discharging and keep fluid evaporation to a minimum.

During the storage period, recheck electrolyte level and specific gravity readings at least every 40 days. As necessary, keep the battery at its upper level line and near full charge as possible (trickle charge).

ACTIVATION OF NEW BATTERY

⚠ WARNING
 Never charge or boost battery while installed on vehicle.

CAUTION: Prior to charging the battery, always remove it from the vehicle to prevent electrolyte spillage.

A new battery is factory fresh dry charged. For storage purposes, it is fitted with a temporary sealing tube.

Do not remove the sealing tube or loosen battery caps unless activation is desired.

In case of accidental premature removal of caps or sealing tube, battery should be given a full charge.

Perform the following operations anytime a new battery is to be installed.

1. Remove the sealing tube from the vent elbow. Install vent tube, included in the battery kit, to battery elbow.

⚠ WARNING
 Failure to remove the sealing tube could result in an explosion.

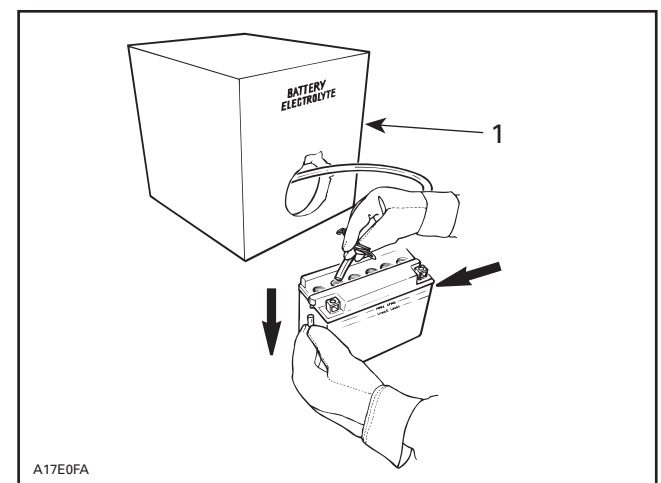

1. Battery electrolyte

Section 06 ELECTRICAL

Subsection 04 (BATTERY)

2. Remove caps and fill battery to UPPER LEVEL line with electrolyte (specific gravity: 1.260 at 20°C (68°F)).
3. Allow the battery to stand for 30 minutes MINIMUM so that electrolyte soaks through battery cells.

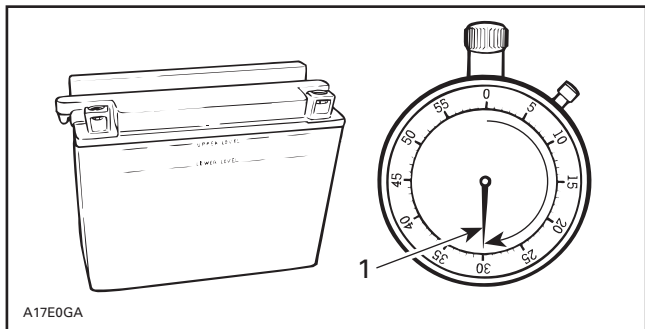

1. 30 minutes

4. Allow gas bubbles to escape by lightly shaking battery by hand.

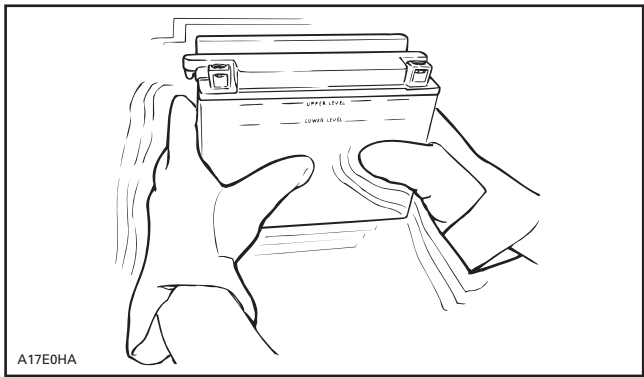

5. Readjust the electrolyte level to the UPPER LEVEL line.

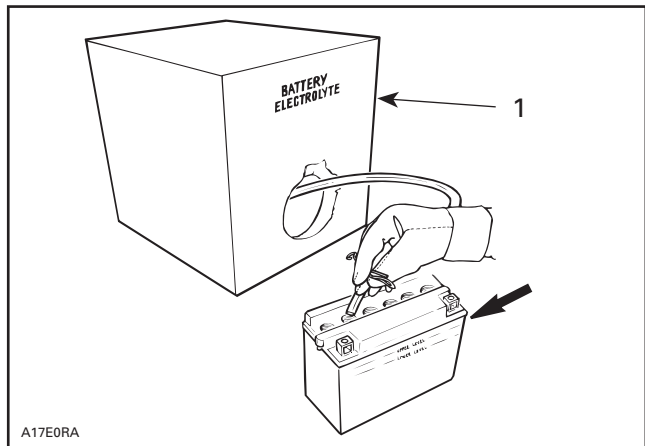

1. Battery electrolyte

6. Connect a 2 A battery charger for 10 to 20 hours.

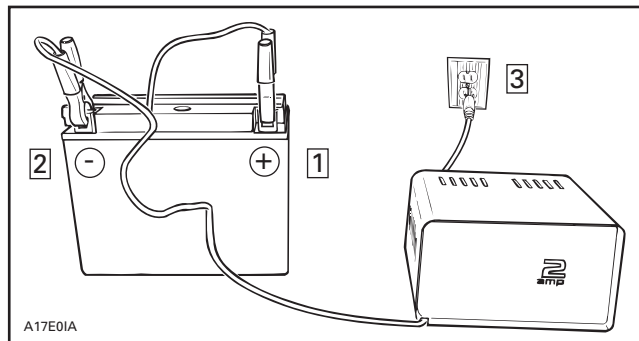

CAUTION: If charging rate raises higher than 2.4 A reduce it immediately. If cell temperature rises higher than 50°C (122°F) (if the casing feels hot) discontinue charging temporarily or reduce the charging rate.

⚠ WARNING

Gases given off by a battery being charged are highly explosive. Always charge in a well ventilated area. Keep battery away from cigarettes or open flames. Always turn battery charger off prior to disconnecting cables. Otherwise a spark will occur and battery might explode.

7. Disconnect battery charger.

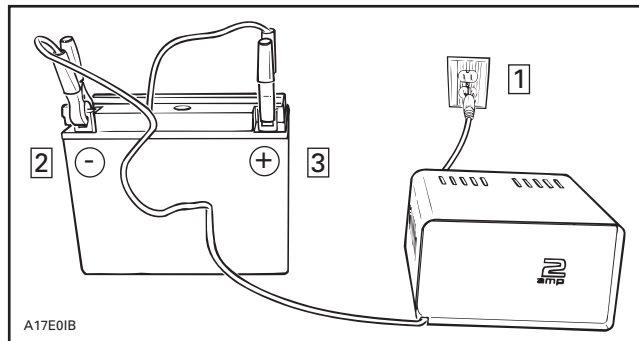

8. Test battery state of charge. Use a hydrometer.

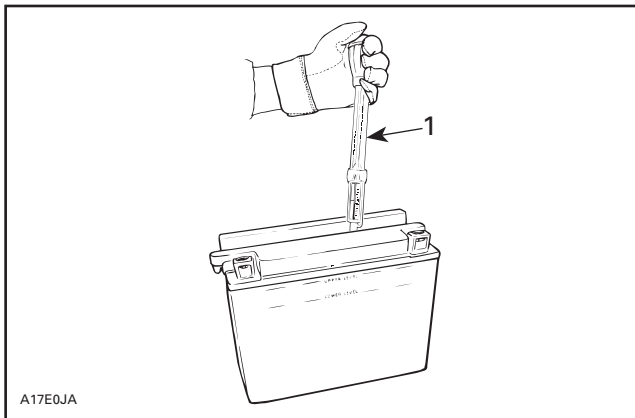

1. Specific gravity 1.260

9. Let battery settle for 1 hour.

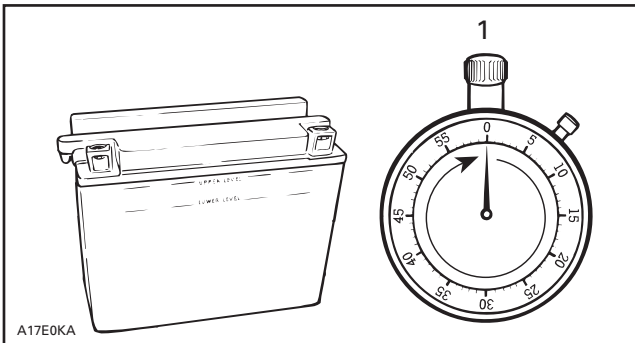

1. 60 minutes

10. Allow gas bubbles to escape by lightly shake battery.

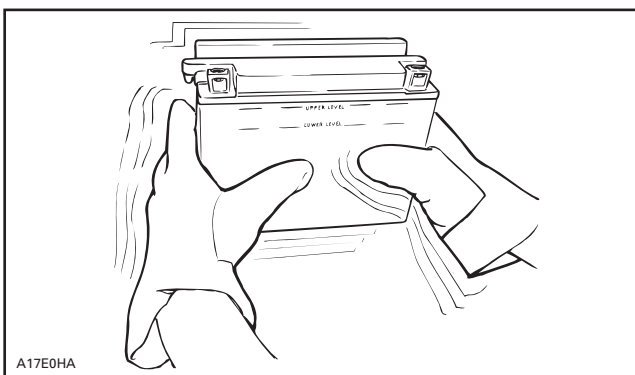

11. Readjust electrolyte level.

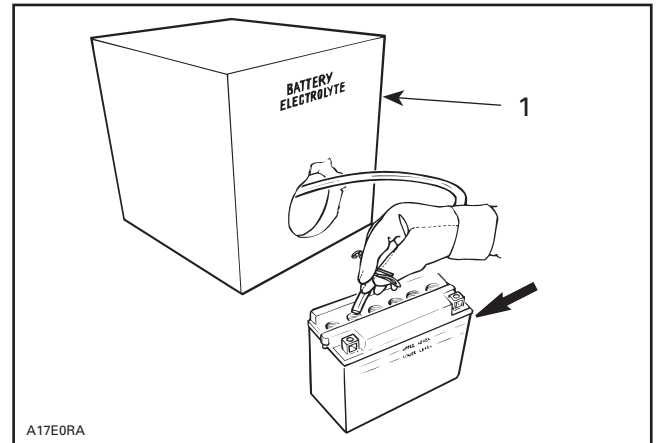

1. Battery electrolyte

12. Reinstall caps and clean any electrolyte spillage using a solution of baking soda and water.

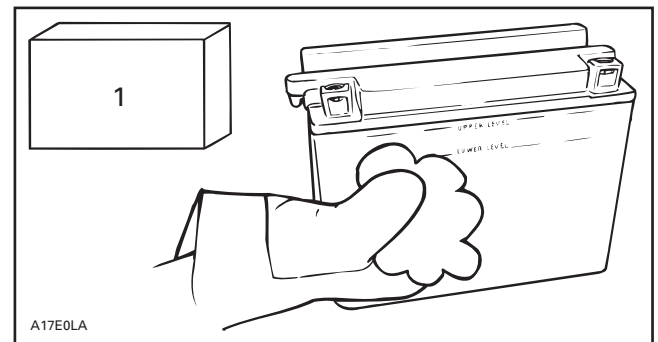

1. Baking soda

CAUTION: Do not allow cleaning solution to enter battery interior since it will destroy the electrolyte.

NOTE: It is recommended to verify the battery charge once a month. If necessary, fully charge battery.

SERVICING

Electrolyte Level

Since a battery has been activated (see above), add distilled water to top up electrolyte.

Section 06 ELECTRICAL

Subsection 04 (BATTERY)

TIPS FOR CHARGING A USED BATTERY

CAUTION: Prior to charging the battery, always remove it from the vehicle to prevent electrolyte spillage.

For best results, battery should be charged when the electrolyte and the plates are at room temperature. A battery that is cold may not accept current for several hours after charging begun.

Do not charge frozen battery. If the battery charge is very low, the battery may freeze. If it is suspected to be frozen, keep it in a heated area for about 2 hours before charging.

WARNING

Do not place battery near open flame.

Time required to charge a battery will vary depending some factors such as:

- **Battery temperature:** Charging time is increased as the temperature goes down. The current accepted by a cold battery will remain low. As the battery warms up, it will accept a higher rate of charge.
- **State of charge:** Because the electrolyte is nearly pure water in a completely discharged battery, it cannot accept current as well as electrolyte. This is the reason the battery will not accept current when the charging cycle first begins. As the battery remains on the charger, the current from the charger causes the electrolytic acid content to rise which makes the electrolyte a better conductor and then, the battery will accept a higher charging rate.
- **Type of charger:** Battery chargers vary in the amount of voltage and current that they can supply. Therefore, time required for the battery to begin accepting measurable current will also vary.

Charging a Very Flat or Completely Discharged Battery

Unless this procedure is properly followed, a good battery may be needlessly replaced.

- Measure the voltage at the battery posts with an accurate voltmeter. If it is below 10 volts, the battery will accept current at very low rate, in term of milliamperes, because electrolyte is nearly pure water as explained above. It could be some time before the charging rate increases. Such low current flow may not be detectable on some charger ammeters and the battery will seem not to accept any charge.
- Only for this particular case, set the charger to a high rate.

NOTE: Some chargers have a polarity protection feature which prevents charging unless the charger leads are connected to the correct battery terminals. A completely discharged battery may not have enough voltage to activate this circuitry, even though the leads are connected properly. This will make it appear that the battery will not accept a charge. Follow the charger manufacturer's instruction telling how to bypass or override this circuitry so that the charger will turn on and charge a low-voltage battery.

- Since the battery chargers vary in the amount of voltage and current they provide, the time required for the battery to accept measurable charger current might be up to approximately 10 hours or more.
- If the charging current is not up to a measurable amount at the end of about 10 hours, the battery should be replaced.
- If the charging current is measurable before the end or at the end of about 10 hours, the battery is good and charging should be completed in the normal manner as specified in **Activation of a new battery**.
- It is recommended that any battery recharged by this procedure be load tested prior to returning it to service.

BATTERY CHARGING EQUIPMENT

The battery charger should have an adjustable charging rate. Variable adjustment is preferred, but a unit which can be adjusted in small increments is acceptable.

The battery charger must be equipped with an ammeter capable of accurately measuring current of less than one ampere.

If the present charger is not adjustable to the proper current values, a rheostat can be connected in series with the battery to provide adjustment. 12 ohm, 50 watt rheostat, such as OHMITE — 0314 or MALLORY 50K 12P, are available from electronic parts supply shops and they are suitable for use with most chargers if the peak current is to be held below 2 A.

If you need an accurate ammeter, we recommend the use of: SHURITE — 5202 (0 to 3 A) or — 5203 (0 to 5 A) available from electronic parts supply shops.

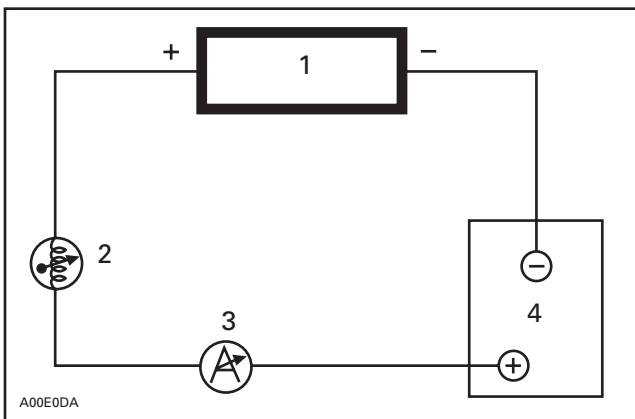

1. Charger
2. Rheostat 12 Ω 50 W
3. Ammeter
4. Battery

For a service application and a permanent installation, both ammeter and rheostat can be built into a small box adjacent to your charger.

CAUTION: Adequate ventilation **MUST** be provided to cool the rheostat.

Charging 2 or More Batteries at a Time

Connect all positives together and use a charger with a capacity (rated) equal to: number of batteries to be charged multiply by 2 A.

For example: charging 5 batteries at a time requires a 10 A rated charger ($5 \times 2 \text{ A} = 10 \text{ A}$).

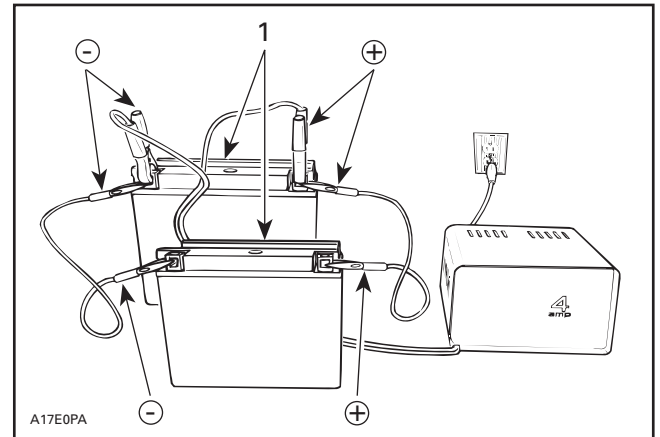

TYPICAL

1. Two batteries = 4 A

INSTALLATION OF BATTERY

Ensure vent tube is properly installed on battery elbow.

Connect vent tube to vehicle fitting on front frame.

Route RED positive cable behind retaining strip and connect it to positive battery terminal. Connect RED wire (coming from ignition switch).

Connect BLACK negative cable LAST.

CAUTION: Negative battery terminal should always be disconnected **FIRST** and reconnected **LAST**.

Apply silicone dielectric grease (P/N 413 701 700) on battery posts and connectors.

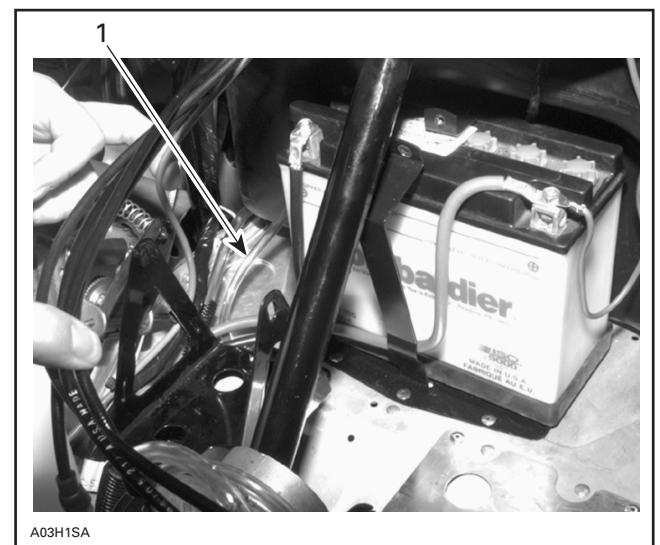

BATTERY CONNECTION

1. Vent tube on fitting

Section 06 ELECTRICAL

Subsection 04 (BATTERY)

Ensure that vent tube is not kinked or blocked then install protective boot over battery.

Close and fasten retaining strips.

Reinstall air silencer.

Fan Cooled S-Series

Fasten spark plug cables to fan housing.

Reinstall throttle cable to air silencer. See removal illustration.

ELECTRIC STARTER

S-Series with Electric Starting and Skandic WT/SWT

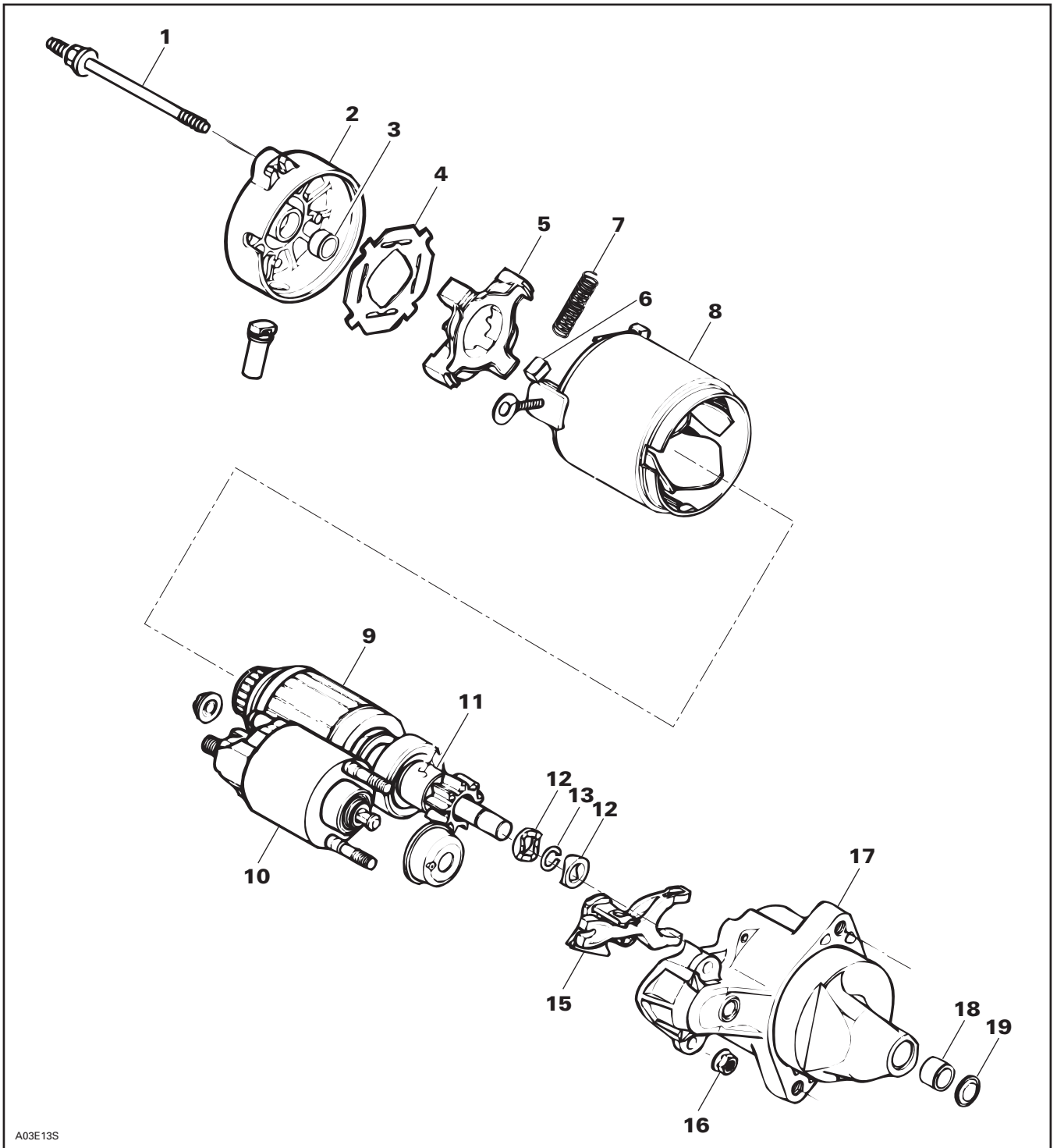

A03E13S

Section 06 ELECTRICAL

Subsection 05 (ELECTRIC STARTER)

REMOVAL

- Disconnect BLACK ground cable from battery.
- Disconnect RED positive cable from battery.

⚠ WARNING

Always disconnect ground cable first and connect last.

- Disconnect RED cable and RED/GREEN wire from starter solenoid switch.
- Remove starter from engine.

DISASSEMBLY

Disconnect bare wire linking starter and solenoid. Remove nuts **no. 16** then solenoid switch **no. 10** by lifting and pulling to disengage from drive lever **no. 15**.

Unscrew starter screws (long) **no. 1** then pull yoke **no. 8** with end frame **no. 2** to separate from drive housing **no. 17**.

Pull armature **no. 9** with drive lever **no. 15**.

Remove insulator **no. 4** then brush springs **no. 7** being careful not to lose them since they will be projected out.

Pull brush holder **no. 5** from yoke **no. 8**.

Insert blade of a small screwdriver between stop collars.

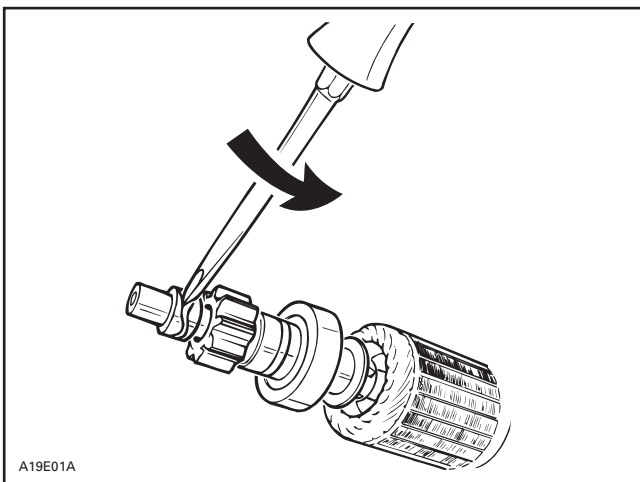

Twist screwdriver to separate stop collars **no. 12** thus giving access to circlip **no. 13**.

Remove outer collar, circlip then inner collar.

Remove overrunning clutch **no. 11**.

Check the wear on bushing **no. 18** by measuring the amount of radial play between the armature shaft and the bushing.

The radial play should not exceed 0.20 mm (.008 in). If greater, replace the bushing. To replace, press out the old one toward bushing cover and press in a new one with a bushing pusher. The correct size of the bushing pusher to use is given on next illustration.

CAUTION: Support drive housing adequately to prevent damage when pressing bushing.

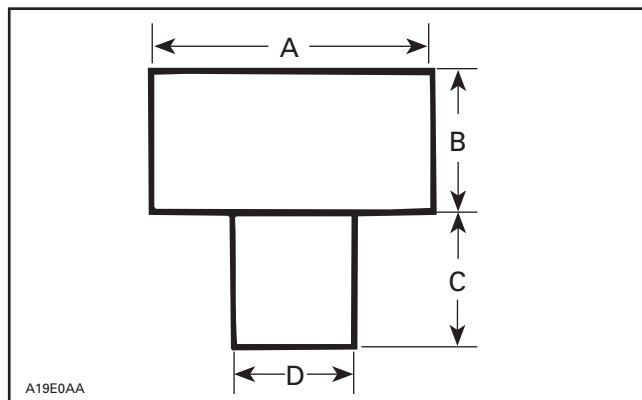

BUSHING PUSHER

- A. 16 mm (5/8 in) diameter
- B. 13 mm (1/2 in)
- C. 11 mm (7/16 in)
- D. 11.0 mm (.433 in)

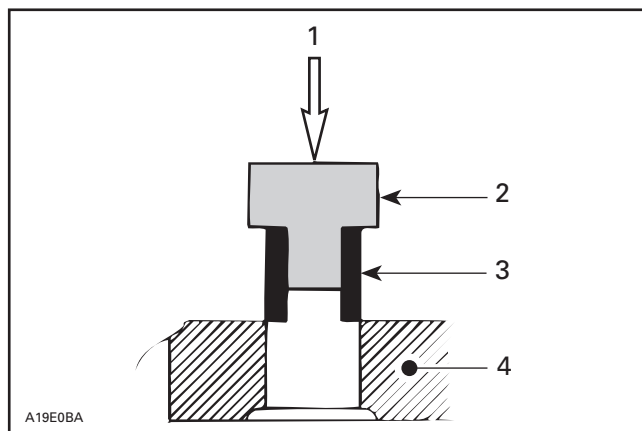

- 1. Press-in
- 2. Bushing pusher
- 3. Bushing
- 4. Drive housing

Install bushing cover **no. 19** then, using a punch, stake bushing cover in place.

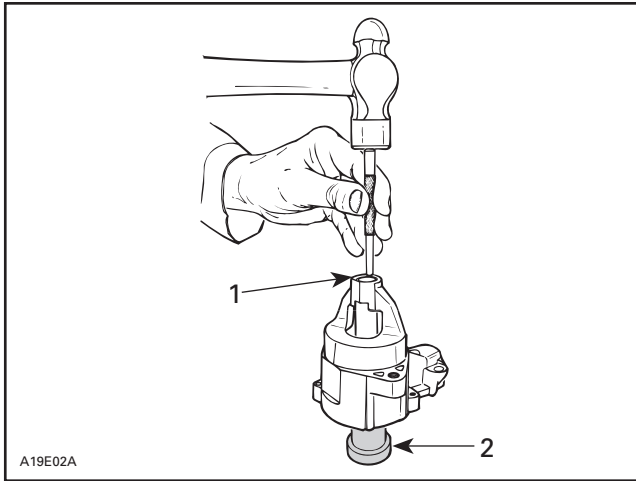

1. Stake bushing cover
2. Support

3, Bushing (end frame)

Check the wear on bushing **no. 3** by measuring the amount of radial play between the armature shaft and the bushing.

The radial play should not exceed 0.20 mm (.008 in). If greater, replace bushing as follows:

Using a 12 mm tap, cut threads into bushing so that the tap contacts the end frame. Continue to rotate tap until the bushing comes free.

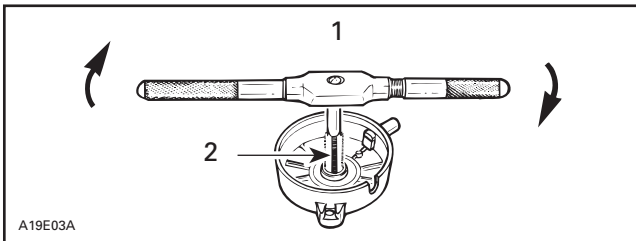

1. Turn until bushing goes out
2. 12 mm tap

To install new bushing, use the same bushing pusher as for drive housing bushing installation.

6, Brush

To replace brush **no. 6**, proceed as follows:

Cut brush wire close to connector at the welded portion.

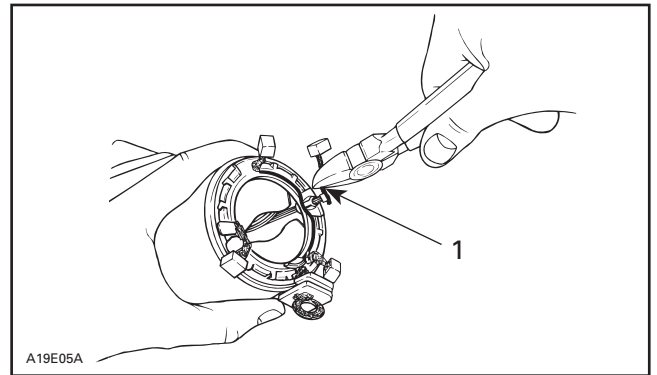

1. Cut close to connector

Remove burrs with a file on the remaining welded portion.

CAUTION: Be careful not to damage plastic portion of yoke.

Place spare brush plate edge against yoke connector edge (welded portion).

Crimp plate over yoke connector with a pair of pliers.

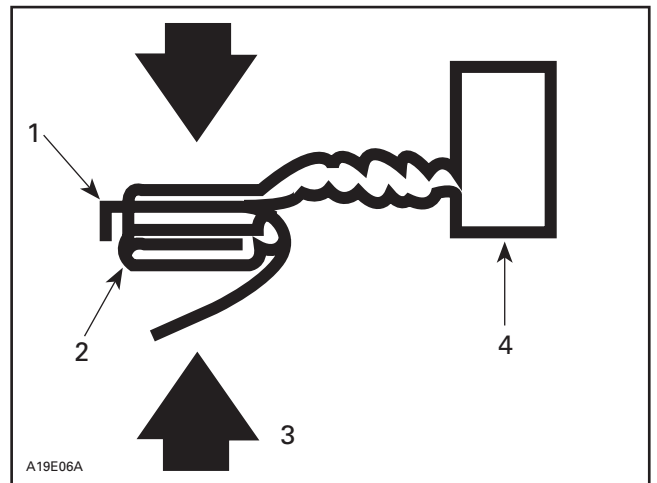

1. Plate edge
2. Yoke connector
3. Crimp
4. Spare brush

Solder the crimped portion.

CAUTION: Do not overheat and quickly perform soldering to prevent solder from flowing to the brush through the wire. Preferably use a heat sink.

Section 06 ELECTRICAL

Subsection 05 (ELECTRIC STARTER)

CLEANING AND INSPECTION

CLEANING

CAUTION: Armature starter yoke ass'y and drive unit assembly must not be immersed in cleaning solvent.

Clean brushes and holder with a clean cloth soaked in solvent. Brushes must be dried thoroughly with a clean cloth.

Blow brush holder clean using compressed air.

WARNING

Always wear safety goggles when using compressed air.

Remove dirt, oil or grease from commutator using a clean cloth soaked in suitable solvent. Dry well using a clean, dry cloth.

Clean engine starter gear teeth and drive unit (clutch).

NOTE: Bushings must not be cleaned with grease dissolving agents.

Immerse all metal components in cleaning solution. Dry using a clean, dry cloth.

INSPECTION

Armature

NOTE: An ohmmeter may be used for the following testing procedures, except for the one concerning the shorted windings in the armature.

Check the commutator for roughness, burnt or scored surface. If necessary, turn the commutator on a lathe, enough to remove grime only.

Check the commutator for mica depth. If the depth is less than 0.20 mm (.008 in), undercut the mica. Be sure that no burrs are left and no copper dust remains between the segments after the undercutting operation is completed.

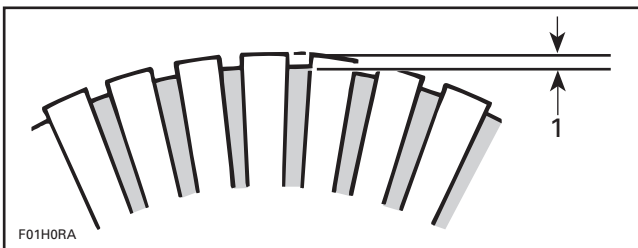

1. Commutator undercut 0.20 mm (.008 in)

Check the commutator out-of-round condition with V Blocks and an indicator. If the commutator out-of-round is more than 0.40 mm (.016 in), the commutator should be turned on a lathe.

Check commutator outer diameter. If less than specified value, replace.

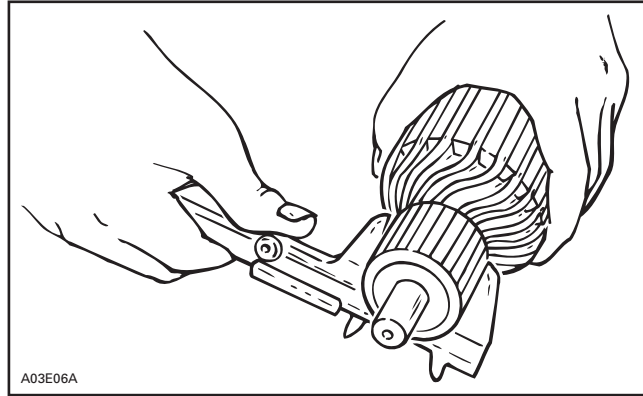

MODEL	WEAR LIMIT
S-Series	27 mm (1.063 in)

Test for Ground Circuit in the Armature:

Use growler test probes. Check between armature core and the commutator bars. If growler lamp turns on, bars are grounded. If so, replace armature.

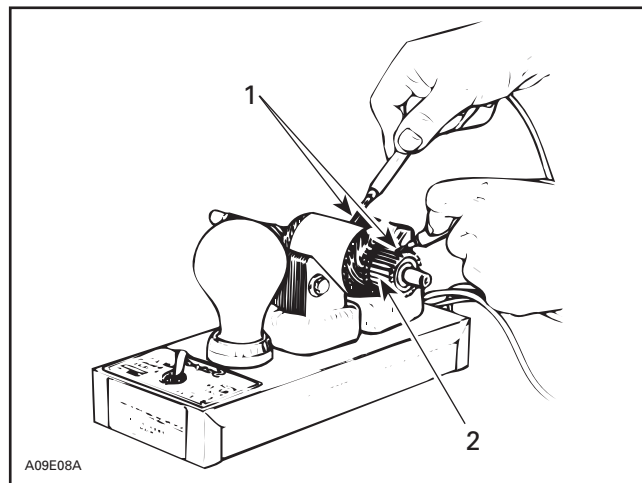

1. Test probes
2. Commutator bars

Test Armature for Shorted Winding:

When the armature is rotated in the growler with a steel strip (hacksaw blade) held above it, the strip will vibrate over that area of the armature which has short circuit. Replace armature if so.

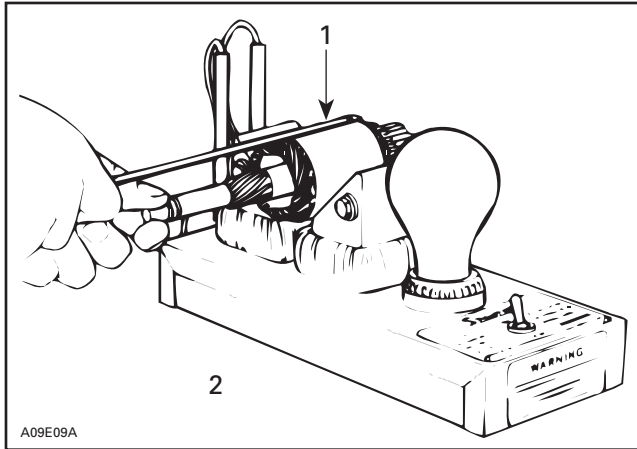

1. Steel strip (hack-saw blade)
2. Growler

Test the Armature for Open Circuit:

Use growler test probes. Place one test probe on a commutator bar and the other test probe on the neighboring bar. Repeat this operation for all bars, moving one test probe at a time. If the growler lamp does not turn on, the armature circuit between these 2 bars is opened. The armature should be replaced or repaired; open circuits most often occur at the commutator riser where coils are soldered. (Burnt commutator bars are usually an indication of an open-circuit armature coil).

Field Windings and Brushes

Test the Field Winding for Open Circuit:

Use growler test probes. Place one test probe on the negative brush and the other test probe on the yoke. If growler lamp does not turn on, the field winding has an open-circuit. The yoke has to be repaired or replaced.

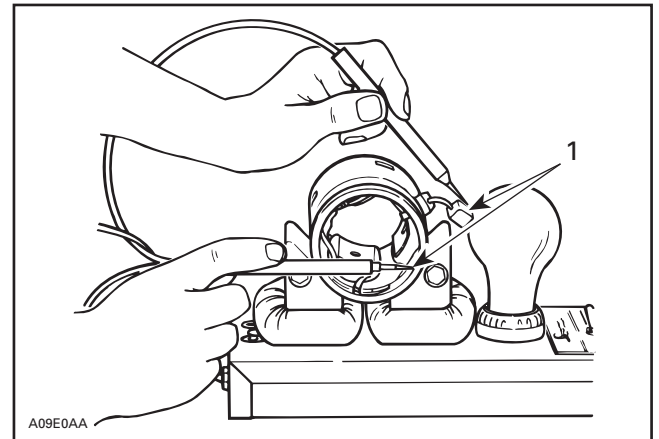

1. Test probes

Check the dynamic brake winding for open circuit by placing one test probe on the positive brush and the other probe on the negative brush.

If growler lamp does not turn on, the winding circuit is open-circuit and the yoke has to be repaired or replaced.

Brush Holder

Check the brush holder for insulation using growler test probes. Place one test probe on the insulated brush holder and the other test probe on the brush holder plate. If the growler lamp turns on, the brush holder has to be repaired or replaced.

Brush Length

Measure brush length. If less than the specified value, replace them.

MODEL	LENGTH	
	NEW	WEAR LIMIT
S-Series Skandic WT/SWT	10 mm (.400 in)	6 mm (.236 in)

Section 06 ELECTRICAL

Subsection 05 (ELECTRIC STARTER)

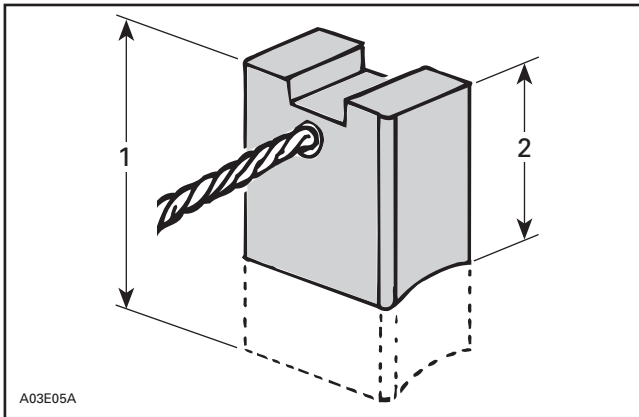

TYPICAL

1. New
2. Wear limit

Overrunning Clutch

The pinion of the overrunning clutch should turn smoothly in a clockwise direction, and should not slip in a counterclockwise direction. If defective, replace.

Check the pinion teeth for wear and damage. If defective, replace.

SOLENOID SWITCH

Inspect connections and clean as necessary. Solenoid switch condition can be checked with an ohmmeter. Install test probes on **large** connectors of solenoid when it is activated (+ on RED/GREEN wire and - on solenoid body).

IMPORTANT: No current must be present on large cables when using ohmmeter, otherwise meter could be damaged.

ASSEMBLY

Prior to assembling, coat sliding surfaces and moving parts on armature shaft splines, overrunning clutch, solenoid switch plunger, drive lever and bushings with G.E. Versilube G 321 (P/N 413 704 000) lubricant.

Proceed as follows for assembling.

Secure drive housing in a vise.

CAUTION: Do not overtighten since housing might be damaged.

Install overrunning clutch onto armature shaft. Insert inner collar onto shaft. Install a new circlip.

CAUTION: Always install a new circlip when servicing.

Insert **outer** collar being careful to match protrusions with notches of collars.

Using a pair of pliers on each side of stop collars, squeeze evenly until collars sit over circlip.

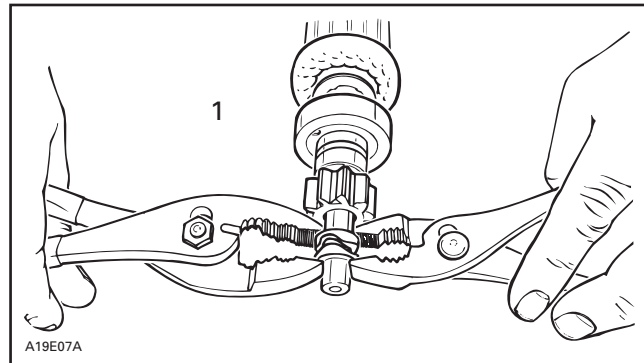

1. Squeeze evenly

Install thrust washer against outer stop collar. Place drive lever onto overrunning clutch then insert into drive housing.

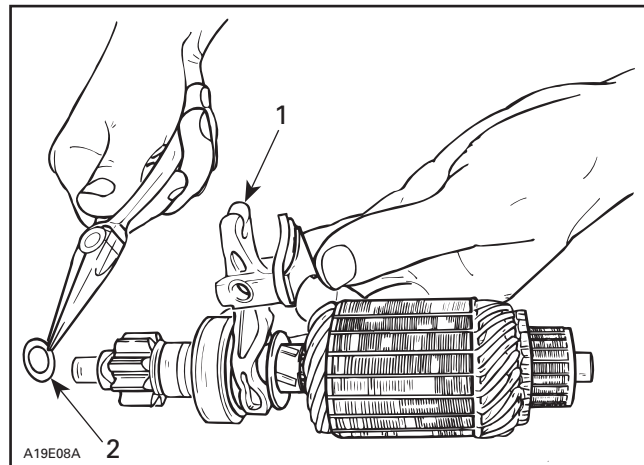

1. Install on overrunning clutch
2. Install thrust washer

Slide yoke over armature.

Install brush holder then brushes in their housings. Insert springs as follows: place one end of spring against brush, compress, then push the other end of spring onto its housing. Repeat for remaining springs.

Section 06 ELECTRICAL
Subsection 05 (ELECTRIC STARTER)

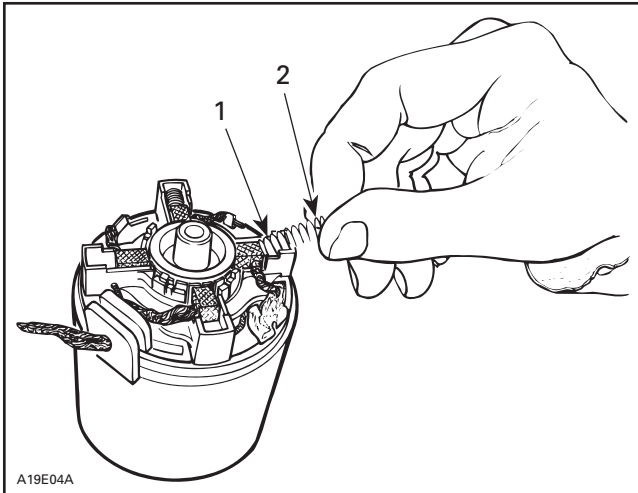

1. This end first
2. Push this end to complete

Secure insulator over brushes and springs. Properly install end frame and tighten screws.

Insert solenoid plunger inside of drive lever fork and secure to drive housing.

Connect starter bare wire to solenoid.

NOTE: Connect this wire on the **shorter** solenoid stud.

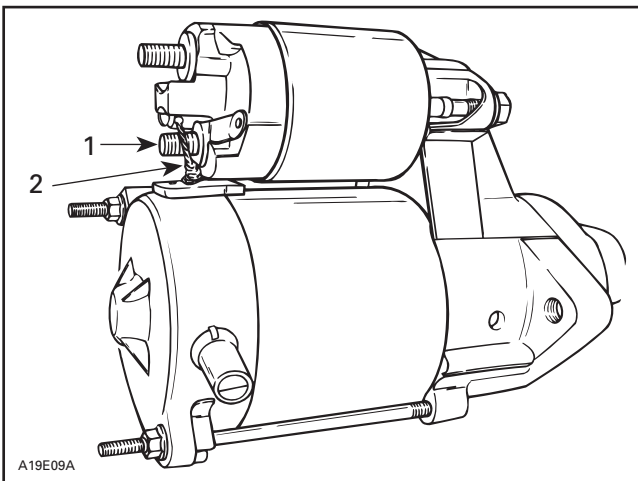

1. Shorter stud
2. Bare wire

INSTALLATION

Make sure that starter and engine mating surfaces are free of grime. Serious trouble may arise if starter is not properly aligned.

Install starter.

NOTE: Check proper engaging depth of starter pinion teeth to ring gear teeth (see illustration). Install hardened washers (P/N 503 007 900) between engine and starter supports accordingly.

CAUTION: All starter bracket fasteners must be secured with Loctite 271 (P/N 413 707 400).

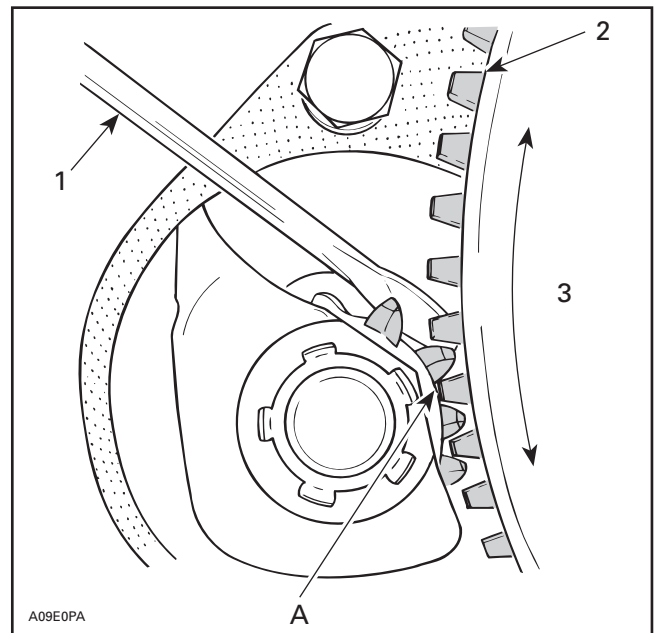

1. Screwdriver pulling starter pinion
2. Ring gear
3. No excessive backlash
- A. 0.5 to 1.5 mm (.020 to .060 in)

Connect the RED battery cable and the RED wire to the large terminal of the solenoid. Connect RED/GREEN wire to small terminal of solenoid.

Connect BLACK cable to battery.

⚠ WARNING

Always disconnect ground cable first and connect last.

Section 06 ELECTRICAL

Subsection 05 (ELECTRIC STARTER)

Skandic WT LC

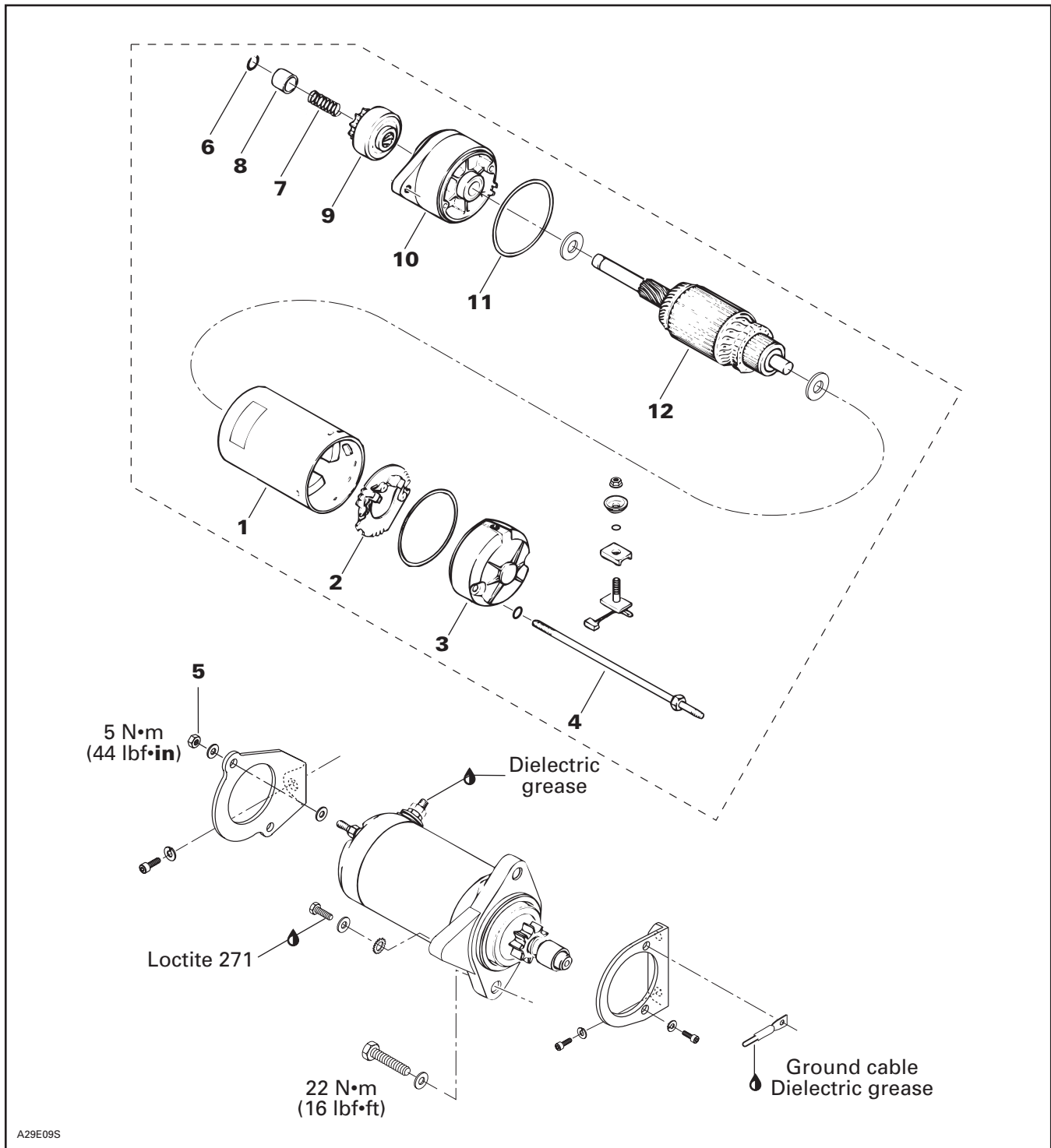

STARTER REMOVAL

Disconnect BLACK cable ground connection from battery.

⚠ WARNING

Always disconnect ground cable first and re-connect last.

Remove tuned pipe.

Cut locking tie retaining cable to starter.

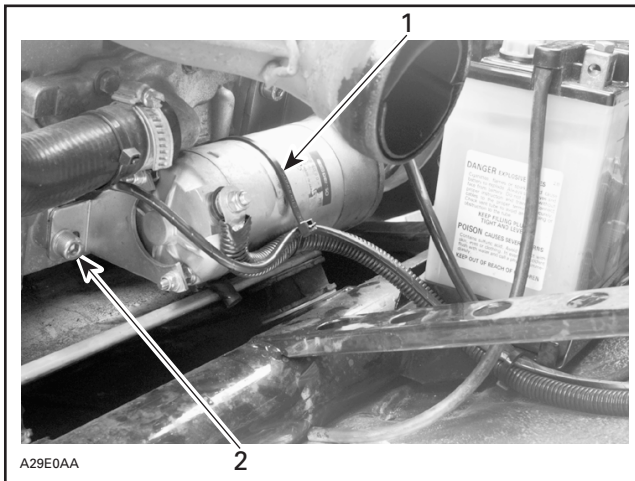

1. Locking tie
2. Allen screw

Unplug positive cable from starter.

Unfasten Allen screw from rear of starter.

Remove 2 screws from front of starter. Top screw also retains positive cable.

Remove starter.

STARTER DISASSEMBLY

1,2,3,4,5, Yoke, Brush Holder, End Frame, Through Bolt and Nut

Before disassembling, trace index marks on yoke and clutch housing to ease further assembly.

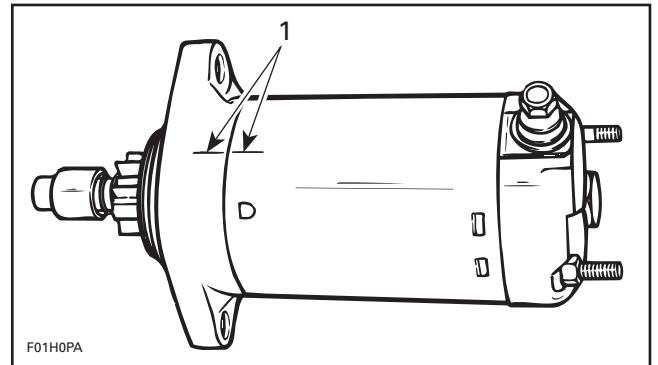

TYPICAL

1. Trace indexing marks

Remove starter support nuts then through bolts. Separate end frame from yoke assembly. Withdraw yoke assembly from armature.

Brush holder can be removed from end frame by unscrewing nut retaining terminal.

Check that the radial play between the armature shaft and end frame is not greater than 0.20 mm (.008 in). Replace end frame if so.

6,7,8, Circlip, Spring and Pinion Stop Collar

Tap the pinion stop collar using a screwdriver. Remove circlip. Disassemble pinion stop collar and spring.

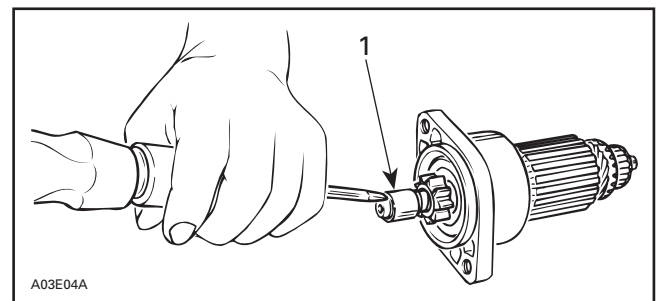

1. Pinion stop collar

9,10,11,12, Clutch Ass'y, Housing, O-Ring and Armature

Turn assembly clockwise to remove it from armature assembly.

Pull housing from armature.

Section 06 ELECTRICAL

Subsection 05 (ELECTRIC STARTER)

CLEANING

CAUTION: Yoke ass'y and drive unit assembly must not be immersed in cleaning solvent.

Discard all O-rings and gasket.

Clean brushes and holders with a clean cloth soaked in solvent. Brushes must be dried thoroughly with a clean cloth.

Blow brush holders clean using compressed air.

⚠ WARNING

Always wear safety glasses when using compressed air.

Remove dirt, oil or grease from commutator using a clean cloth soaked in suitable solvent. Dry well using a clean, dry cloth.

Clean engine ring gear teeth and drive unit (clutch).

NOTE: Bushings must not be cleaned with grease dissolving agents.

Immerse all metal components in cleaning solution. Dry using a clean, dry cloth.

PARTS INSPECTION

Armature

NOTE: An ohmmeter may be used for the following testing procedures, except for the one concerning shorted windings in armature.

Check commutator for roughness, burnt or scored surface. If necessary, turn commutator on a lathe, enough to resurface only.

Check commutator for mica depth. If depth is less than 0.20 mm (.008 in), undercut mica. Be sure that no burrs are left and no copper dust remains between segments after undercutting operation is completed.

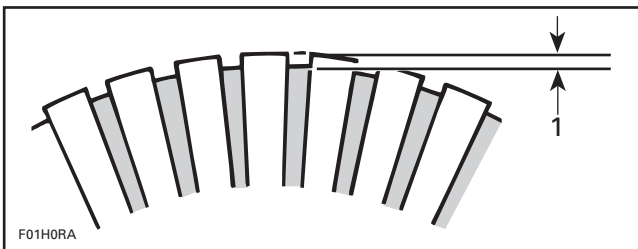

1. Commutator undercut 0.20 mm (.008 in)

Check commutator out of round condition with V-shaped blocks and an indicator. If commutator out of round is more than 0.40 mm (.016 in), commutator should be turned on a lathe.

Check commutator outer diameter. If less than 27 mm (1.063 in), replace.

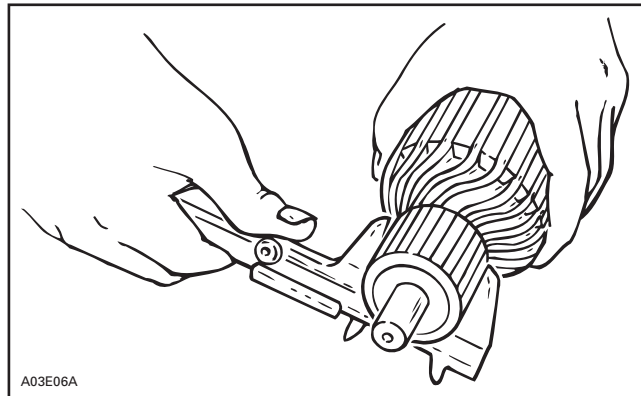

Brush Holder

Check brush holder for insulation using an ohmmeter. Place one test probe on insulated brush holder and the other test probe on brush holder plate. If continuity is found, brush holder has to be repaired or replaced.

Brush Length

Measure brush length. If less than 8.5 mm (.335 in), replace them.

NOTE: New brush length is 12 mm (.472 in).

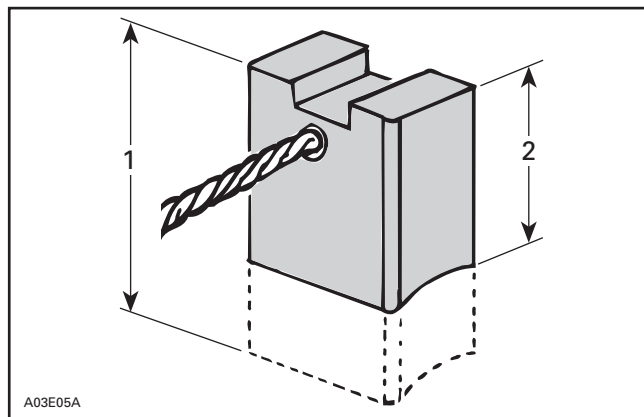

1. New
2. Wear limit, 8.5 mm (.335 in)

Overrunning Clutch

Pinion of overrunning clutch should turn smoothly in a clockwise direction, and should not slip in a counterclockwise direction. If defective, replace.

Check pinion teeth for wear and damage. If defective, replace.

NOTE: Always check engine ring gear teeth for wear and damage. If defective replace ring gear. Refer to DRIVE PULLEY 05-03.

STARTER ASSEMBLY

Reverse the order of disassembly to reassemble starter. However, attention should be paid to the following operations.

Prior to assembling, coat sliding surfaces on armature shaft splines, overrunning clutch and bushing with G.E. Versilube G 341 M or ESSO Beacon 325 lubricant or equivalent.

Apply motor oil on metal bushings.

6,8, Circlip and Pinion Stop Collar

After placing stop collar on armature shaft, fit circlip into armature shaft, then make sure that it is properly secured.

Slide stop collar over circlip and secure in place by punching it at 2 or 3 places.

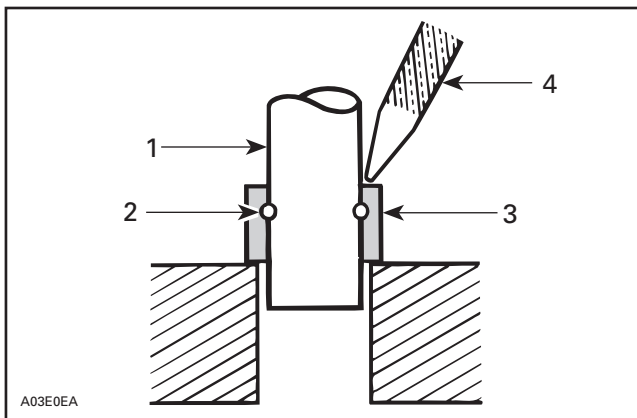

- 1. Armature shaft
- 2. Circlip
- 3. Pinion stop collar
- 4. Punch

1,10, Housing and Yoke Ass'y

Align previously traced indexing marks.

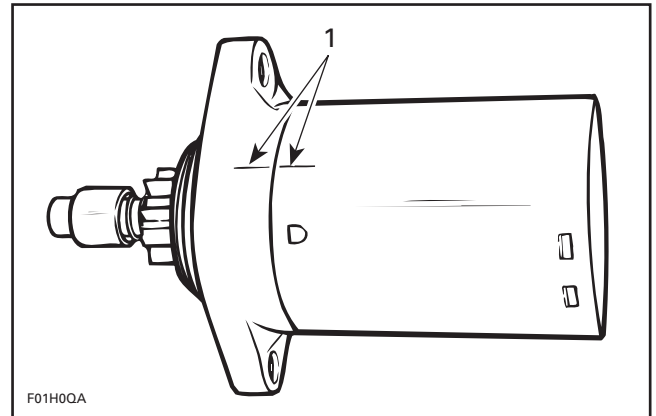

TYPICAL

- 1. Align marks

1,3,4, Yoke Ass'y, End Frame and Through Bolt

Open brushes and slide over commutator.

Align end frame locating notch with yoke locating protrusion and properly sit brush holder into yoke.

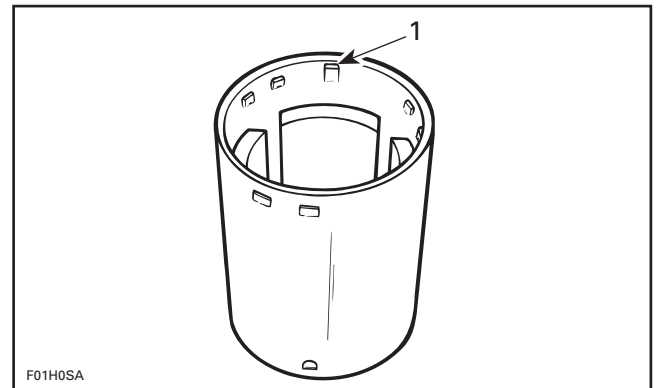

- 1. Locating protrusion is the higher one

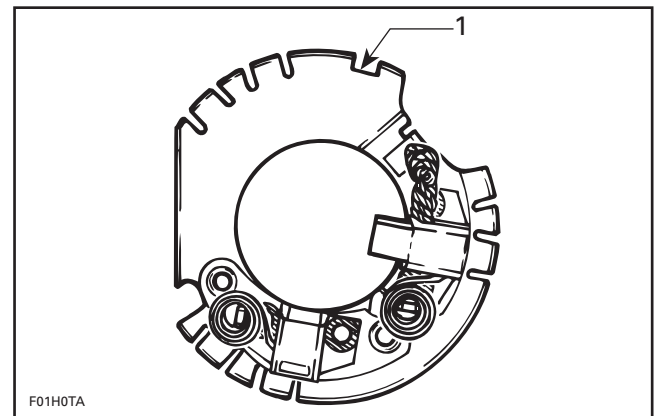

- 1. Brush holder locating notch

Section 06 ELECTRICAL

Subsection 05 (ELECTRIC STARTER)

To ease end frame installation, retain brush holder with a small screwdriver while installing end frame.

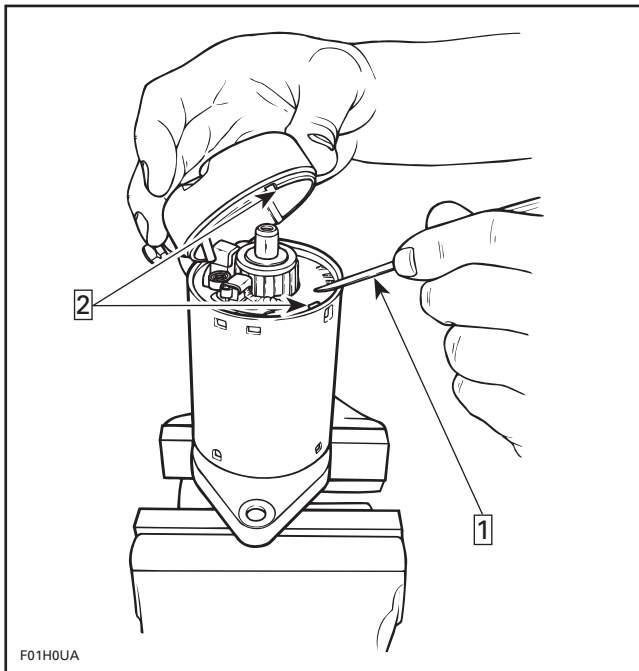

Step **1**: Retaining brush holder with a screwdriver

Step **2**: Align here

Align end frame notch with brush holder notch/yoke protrusion.

CAUTION: Make sure end frame fits perfectly on yoke.

STARTER INSTALLATION

Installation is essentially the reverse of removal procedure. However, pay particular attention to the following.

Make sure that starter and engine mating surfaces are free of debris. Serious trouble may arise if starter is not properly aligned.

⚠ WARNING

Always connect RED positive cable first then BLACK negative cable last. Whenever connecting the RED positive cable to the starter motor make sure the battery cables are disconnected to prevent electric shock.

TESTING PROCEDURE

GENERAL

The following chart gives the engine types with their implemented system.

ENGINE TYPE	IGNITION SYSTEM	CHARGING SYSTEM OUTPUT
277 on Tundra R	① RER dual trigger coil CDI (single cylinder)	240
377, 443 and 503 on Formula S, MX Z 440 and Skandic WT/SWT	② Ducati trigger coil CDI	240
377, 443 and 503 on S-Series with RER	③ RER dual trigger coil CDI (twin cylinder)	240
494	④ Nippondenso trigger coil CDI	220

CDI System Identification

① RER Dual Trigger Coil CDI (single cylinder)

The RER dual trigger coil CDI system has an ignition coil integrated to the MPEM which is mounted on air silencer.

MPEM is programmed to recognize a signal sent by the switch located on snowmobile console.

When switch is activated, MPEM cuts off ignition and engine rev drops at approximately 700 RPM for 277 engine (Tundra R).

MPEM fires a spark at a great advance creating a thrust which reverses engine rotation.

Second trigger coil located on crankcase takes over to produce spark in reverse rotation.

A safety device is incorporated to MPEM preventing it from reading any signal coming from reverse switch at following engine revs.

Below 800 RPM and above 3500 RPM = No reverse signal.

MPEM is connected to a single ignition generator coil via a 3-connector housing (BLACK and RED wires).

Section 06 ELECTRICAL

Subsection 06 (TESTING PROCEDURE)

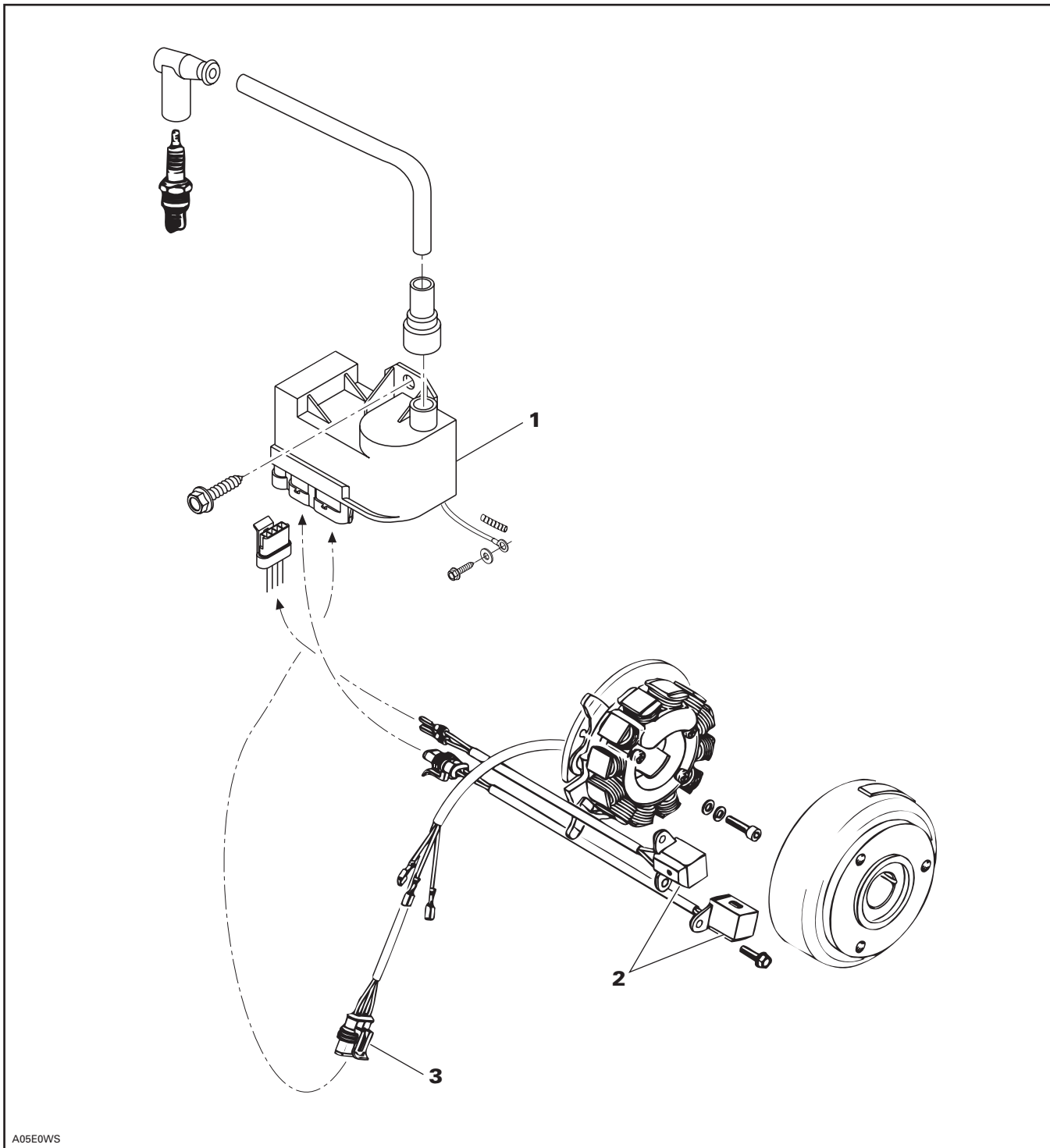

① RER DUAL TRIGGER COIL CDI SYSTEM (SINGLE CYLINDER)

1. MPKM
2. Trigger coils
3. 4-04 housing (BLACK and RED wires)

② **Ducati Trigger Coil CDI**

The DUCATI trigger coil CDI system has a combined ignition module/ignition coil which is mounted on air silencer, below carburetors.

Ignition module is connected to the ignition generator coil via a 4-connector housing (GREEN and WHITE wires).

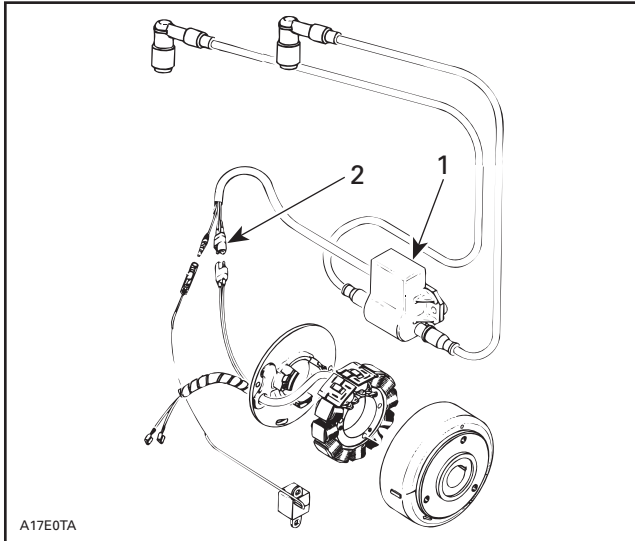

② **DUCATI TRIGGER COIL CDI SYSTEM**

1. Combined ignition module/ignition coil mounted on air silencer below carburetors
2. 4-02 housing (GREEN and WHITE wires)

③ **RER Dual Trigger Coil CDI (twin cylinder)**

The RER dual trigger coil CDI system has an ignition coil integrated to the MPEM which is mounted on oil reservoir.

MPEM is connected to a single ignition generator coil via a 3-connector housing (BLACK and RED wires).

MPEM is programmed to recognize a signal sent by the switch located on snowmobile console.

When switch is activated, MPEM cuts off ignition and engine rev drops at approximately 450 RPM.

MPEM fires a spark at a great advance creating a thrust which reverses engine rotation.

Second trigger coil located on crankcase takes over to produce spark in reverse rotation.

A safety device is incorporated to MPEM preventing it from reading any signal coming from reverse switch at following engine revs.

Below 1000 RPM and above 3500 RPM = No reverse signal.

Section 06 ELECTRICAL

Subsection 06 (TESTING PROCEDURE)

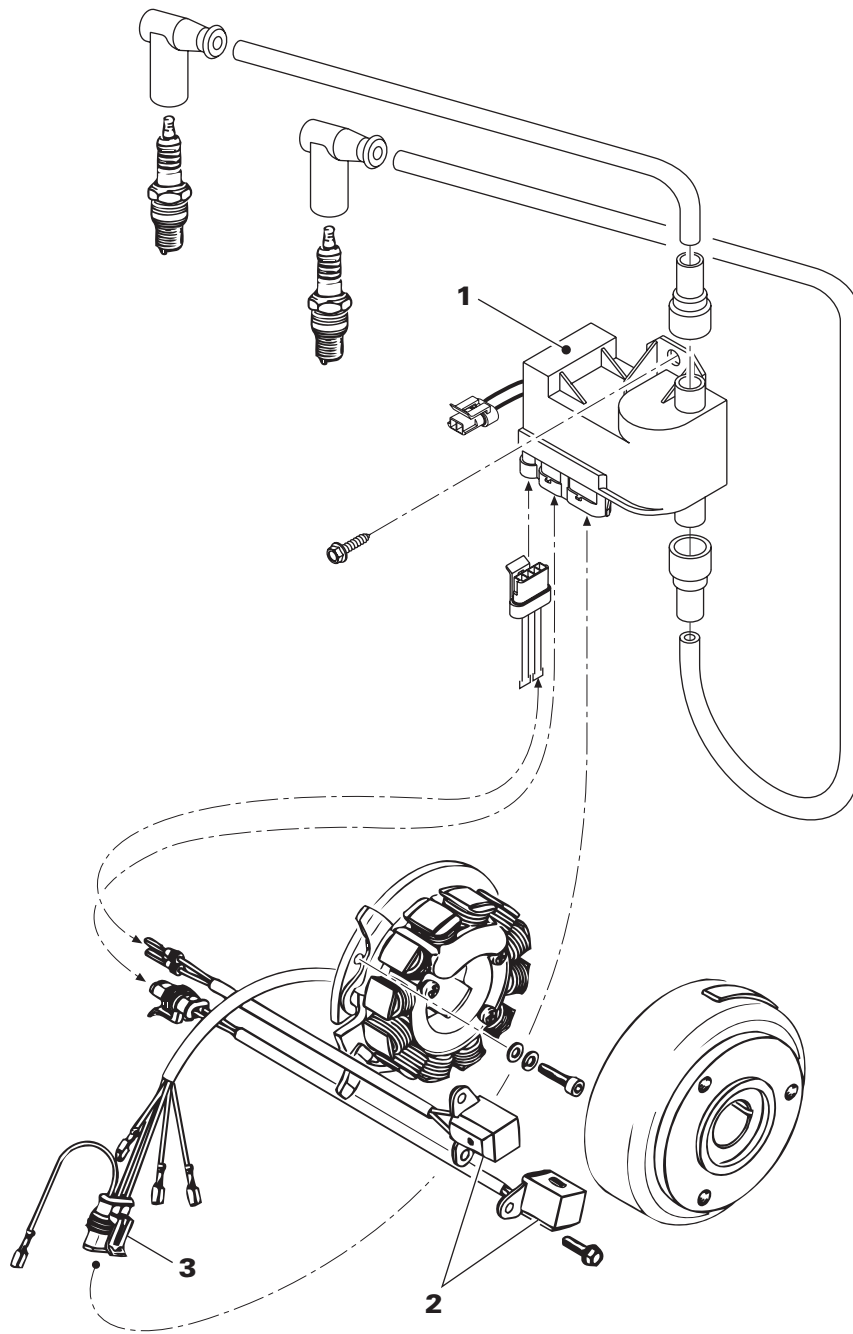

A03E2WS

③ RER DUAL TRIGGER COIL CDI SYSTEM (TWIN CYLINDER)

- 1. MPEM
- 2. Trigger coils
- 3. 2-05 housing (BLACK and RED wires)

④ **Nippondenso**

The NIPPONDENSO CDI system has a separate ignition coil which is mounted on the reservoir support.

1. Ignition module is connected to the ignition generator coil via a 3-wire connector (RED, BLACK/RED and BLACK wires).

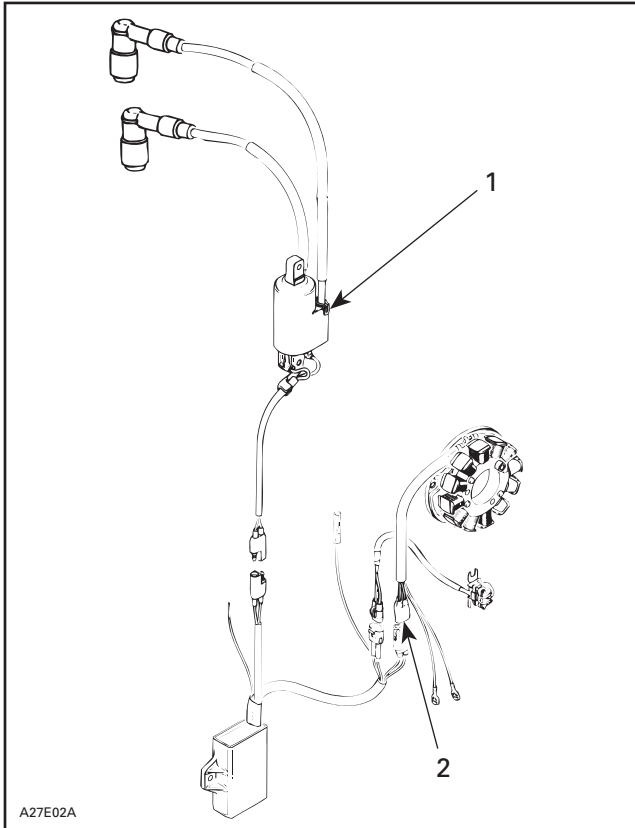

④ **NIPPONDENSO TRIGGER COIL CDI SYSTEM**

1. *Separate ignition coil mounted on reservoir support*
2. *Three-wire connector (RED, BLACK/RED and BLACK)*

Section 06 ELECTRICAL

Subsection 06 (TESTING PROCEDURE)

RER DUAL TRIGGER COIL CDI SYSTEM TESTING

Tundra R and S-series with RER

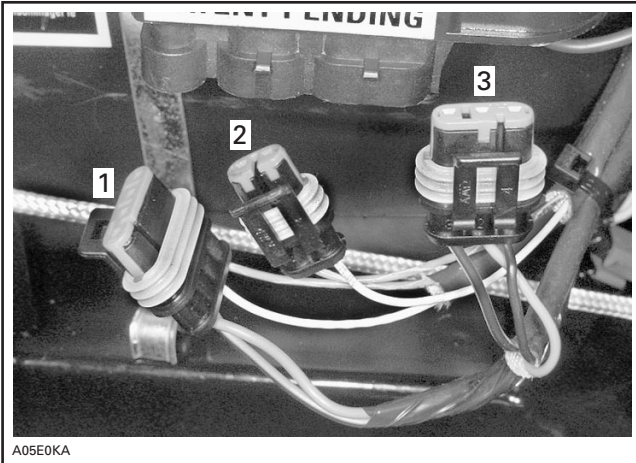

MPEM

1. Reverse switch, reverse indicator and trigger coil
2. Trigger coil
3. Generator output and cut-off switches

IGNITION SYSTEM TESTING SEQUENCE

In case of ignition problems, check the following in the prescribed order until the problem can be solved.

1. Sparking/spark plug condition.
2. Electrical connectors.
3. Ignition switches, tether cord cap and emergency switch.
4. Ignition coil output.
5. Trigger coil output.

NOTE: Refer to DUCATI CDI SYSTEM TESTING and appropriate model IGNITION SYSTEM TESTING TABLE at the end of this chapter for complete detailed testing procedure.

LIGHTING SYSTEM TESTING SEQUENCE

1. Electrical connectors.
2. Magneto output (lighting generator coil).

NOTE: Refer to DUCATI CDI SYSTEM TESTING and appropriate model LIGHTING SYSTEM TESTING TABLE at the end of this chapter for complete detailed testing procedure.

Testing Conditions

Voltage measurements are always taken upon starting the vehicle. Readings taken when the engine is running will be higher than indicated range.

Part temperature must be approximately 21°C (70°F) (room temperature), otherwise readings could be distorted.

Analysis of Readings

Voltage Readings

When testing the different magneto components, it is important to take into consideration that readings vary according to the force applied onto the manual starter. It is therefore important to employ enough force upon each trial.

The reading must be 3 times within or above the range indicated in the corresponding table. If the reading is too low, the part is considered to be defective and it must be replaced.

Resistance Readings

Place multimeter selector switch to Ω in order to measure resistance. Readings must be within the indicated range. Otherwise, the part is considered to be defective and must be replaced.

CAUTION: When taking measurements, it is useless to try to start the vehicle since readings would then be distorted.

Intermittent Ignition Problems

It is difficult to make a diagnostic in the case of intermittent ignition problems. Thus, problems occurring only when the engine operating temperature is normal must be checked in similar conditions.

In most cases when problems are caused by temperature or vibrations, these can only be solved by replacing parts. Most problems cannot be detected when the engine is stopped.

Multiple Problems

As a matter of fact, more than one component can be defective. As a result, if the problem remains although a part was replaced, start over the whole verification from the beginning in order to identify the other defective component.

1. SPARKING

During this operation, it is important to use the snowmobile spark plug and not a new one. Bring the plug in contact with the engine. If no spark is produced, replace the spark plug with a new one and do the test again.

2. ELECTRICAL CONNECTOR TESTING

Make sure that none of the connectors are disconnected.

3. IGNITION SWITCH, TETHER CORD SWITCH AND EMERGENCY SWITCH TESTING

Disconnect connector housing 2-01 from engine, and using a multimeter, check resistance as indicated in IGNITION table.



If readings are acceptable, go on to next step.

If readings are inadequate, individually check each switch as follows.

Ignition Switch (key)

Disconnect switch housing. Using a multimeter, check between **MAG** and **GRD** terminals if the circuit is open ($0.L_{M\Omega}$) in operating position and if the circuit is closed (0_{Ω}) in off position.



TYPICAL

If readings do not correspond to the above-mentioned indications, replace switch.

If readings are acceptable, check other switches.

Emergency Switch

Unplug switch block connected to main wiring harness. Check using a multimeter. Connect probes to 6-02-C-M and 6-02-D-M terminals. The multimeter should indicate an open circuit ($0.L_{M\Omega}$) in operating position and a closed circuit (0_{Ω}) in off position.



TYPICAL

If readings do not correspond to the above-mentioned indications, replace switch.

If readings are acceptable, check other switches.

Section 06 ELECTRICAL

Subsection 06 (TESTING PROCEDURE)

Tether Cord Switch

Unplug switch block connected to main wiring harness. Check using a multimeter by connecting probes to 6-03-B-M and 6-03-A-M wires. The multimeter should indicate an open circuit ($0.L_{M\Omega}$) in operating position and a closed circuit (0_{Ω}) in off position.



TYPICAL

If readings do not correspond to the above-mentioned indications, replace switch.

If readings are acceptable, check other switches. If none of these verifications are conclusive, the problem finds its source in the main wiring harness. Proceed as follows:

NOTE: For this next step, no stop switch must be connected to the main wiring harness.

Disconnect all stop switches from the main wiring harness and check the continuity of each wire by connecting probes to the end of wires of the same color. Repeat with all other wires. It is important to mention that all wires of the same color within a given harness are connected together. These wires should therefore have a closed circuit. On the other hand, BLACK and BLACK/YELLOW wires must have an open circuit ($0.L_{M\Omega}$).

Repair or replace if necessary.

4. IGNITION GENERATOR COIL VOLTAGE TESTING

General

When manually starting the engine while the spark plug is installed, the engine will tend to accelerate beyond the compression point. This will result in higher magneto output power.

1. Disconnect the 3-wire housing between the ignition module and the magneto wiring harness (2-05).
2. Connect multimeter probes to RED and BLACK wires (female end), then bring selector to \checkmark and scale to 00.0^{VAC} .
3. Activate the manual starter and check values indicated by the multimeter.
4. Repeat operation 3 times.



5. Compare readings with those appearing in the IGNITION table.

5. TRIGGER COIL VOLTAGE TESTING

1. Disconnect 4-wire housing between the ignition module and the engine (2-03 and 2-02).
2. Connect multimeter probes to BLACK/YELLOW wire and to WHITE/YELLOW wire, then bring selector switch to \checkmark and scale to 00.0^{VAC} .
3. Activate the manual starter and check values indicated by the multimeter.
4. Repeat operation 3 times.
5. Compare readings with those appearing in the IGNITION table.

BUZZER TESTING

Using jumper wires, connect battery positive post to buzzer positive tab.

Connect battery negative post to buzzer negative tab. See next photo.

CAUTION: To avoid buzzer damage, ensure that polarity is respected.



12-VOLT BATTERY PLUGGED TO BUZZER

MPEM CONNECTORS

To ease electrical readings on MPEM connectors, connector cap must be removed.

Hold connector in hands then lift both tabs to remove connector cap.



LIFT TABS TO REMOVE CAP

Insert multimeter probes into connector.

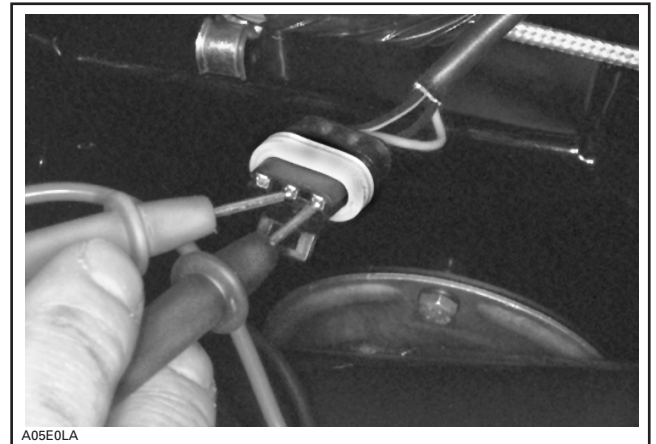

TEST USING MULTIMETER PROBES

Section 06 ELECTRICAL

Subsection 06 (TESTING PROCEDURE)

IGNITION SYSTEM TESTING (Tundra R 240 W)								
PART	TEST TO BE PERFORMED	WIRE COLOR	MULTIMETER PROBE CONNECTION	RESISTANCE Ω		VOLTAGE V		NOTE
				VALUE (OHMS)	MULTIMETER SCALE	VALUE (VOLTS)	MULTIMETER SCALE	
Stop switch	Running insulation	BK BK/YL	4-01C-M 4-01D-M	0.L	00.0 $M\Omega$	—	—	No stop switch must be operational.
	Continuity in STOP position	BK BK/YL	4-01C-M 4-01D-M	00.0 - 00.5	00.0 Ω	—	—	Only one stop switch must be operational. Test them one after the other.
Ignition generator coil	Output	RD BK	4-04-2-F 4-04-1-F	4.5 - 6.5	00.0 Ω	7.0 - 15.0	00.0 ^{VAC}	—
	Ground continuity	BK engine	4-04-1-F engine	00.0 - 00.5	00.0 Ω	—	—	The term "engine" refers to the engine metal parts connected to the magneto housing.
Trigger coil	Front	WH/YL BL/YL	4-03-1-F 4-03-2-F	160 -180	00.0 Ω	.100 - .300	.000 ^{VAC}	—
	Rear	WH/YL BL/YL	4-02-3-F 4-02-4-F	160 -180	00.0 Ω	.100 - .300	.000 ^{VAC}	—
MPEM and high voltage coil	Secondary winding resistance with caps	Spark plug cap engine	In spark plug cap and on the engine	4.90 K - 7.10 K	0.00 $k\Omega$	CAUTION: Do not measure high voltage coil output voltage.		
	Secondary winding resistance without caps	BK engine	Inside spark plug cable and on the engine	0.90 K - 1.10 K	0.00 $k\Omega$	CAUTION: Do not measure high voltage coil output voltage.		
	Secondary winding voltage	BK engine	On spark plug cable housing and on the engine	—	—	.150 - .350	.000 ^{VAC}	The measurement must be taken on the spark plug cable (without the spark plug).
Spark plug cap	Cap resistance	—	Spark plug side and cable side	4.0 K - 6.0 K	00.0 $k\Omega$	—	—	—

NOTE: Stop switches include the ignition switch, the tether cord switch and the emergency cut-out switch. It is important to take note that voltage measurements must be taken while starting the vehicle using the manual starter.

Voltages obtained upon starting are proportional to the force applied onto the manual starter. A low voltage is therefore normal under a low cranking force.

Perform testing in the prescribed order and replace any parts not performing according to specifications.

It is important to resume all tests when replacing a component.

If not specified, the probe connecting sequence is not important.

Section 06 ELECTRICAL
Subsection 06 (TESTING PROCEDURE)

LIGHTING SYSTEM TESTING (Tundra R 240 W)								
PART	TEST TO BE PERFORMED	WIRE COLOR	MULTIMETER PROBE CONNECTION	RESISTANCE Ω		VOLTAGE V		NOTE
				VALUE (OHMS)	MULTIMETER SCALE	VALUE (VOLTS)	MULTIMETER SCALE	
Lighting generator coil	Power	YL YL/BK	4-01B-F 4-01A-F	00.0 - 00.6	00.0 Ω	3.0 - 7.0	00.0 ^{VAC}	—
	Insulation	YL engine	4-01(A,B)-F engine	0.L	00.0 $M\Omega$	—	—	The term "engine" refers to the engine metal parts connected to the magneto housing.
	Ground continuity	BK engine	4-01C-F engine	00.0 - 00.5	00.0 Ω	—	—	—

NOTE: It is important to take note that voltage measurements must be taken while starting the vehicle using the manual starter.

Voltages obtained upon starting are proportional to the force applied onto the manual starter. A low voltage is therefore normal under a low cranking force.

Perform testing in the prescribed order and replace any parts not performing according to specifications. It is important to resume all tests when replacing a component.

If not specified, the probe connecting sequence is not important.

Section 06 ELECTRICAL

Subsection 06 (TESTING PROCEDURE)

IGNITION SYSTEM TESTING (S-Series with RER 240 W)								
PART	TEST TO BE PERFORMED	WIRE COLOR	MULTIMETER PROBE CONNECTION	RESISTANCE Ω		VOLTAGE V		NOTE
				VALUE (OHMS)	MULTIMETER SCALE	VALUE (VOLTS)	MULTIMETER SCALE	
Stop switch	Running insulation	BK BK/YL	2-01C-M 2-01D-M	0.L	00.0 $M\Omega$	—	—	No stop switch must be operational.
	Continuity in STOP position	BK BK/YL	2-01C-M 2-01D-M	00.0 - 00.5	00.0 Ω	—	—	Only one stop switch must be operational. Test them one after the other.
Ignition generator coil	Output	RD BK	2-05-2-F 2-05-1-F	4.5 - 6.5	00.0 Ω	7.0 - 15.0	00.0 ^{VAC}	—
	Ground continuity	BK engine	2-05-1-F engine	00.0 - 00.5	00.0 Ω	—	—	The term "engine" refers to the engine metal parts connected to the magneto housing.
Front trigger coil	Resistance and output	WH/YL BL/YL	2-03-1-F 2-03-2-F	160 - 180	00.0 Ω	.150 - .350	.000 ^{VAC}	—
Rear trigger coil	Resistance and output	WH/YL BL/YL	2-02-3-F 2-02-4-F	160 - 180	00.0 Ω	.150 - .350	.000 ^{VAC}	—
MPEM and high voltage coil	Secondary winding resistance with caps	Spark plug cap Spark plug cap	In spark plug cap	8.90 K - 13.1 K	00.0 $K\Omega$	CAUTION: Do not measure high voltage coil output voltage.		
	Secondary winding resistance without caps	BK BK	Inside spark plug cable	0.90 K - 1.10 K	00.0 $K\Omega$	CAUTION: Do not measure high voltage coil output voltage.		
	Secondary winding voltage	BK engine	On spark plug cable housing and on the engine	—	—	.100 - .250	0.00 ^{VAC}	The measurement must be taken on the spark plug cable (without the spark plug).
Spark plug cap	Cap resistance	—	Spark plug side and cable side	4.0 K - 6.0 K	00.0 $K\Omega$	—	—	—

NOTE: Stop switches include the ignition switch, the tether cord switch and the emergency cut-out switch.

It is important to take note that voltage measurements must be taken while starting the vehicle using the manual starter.

Voltages obtained upon starting are proportional to the force applied onto the manual starter. A low voltage is therefore normal under a low cranking force.

Perform testing in the prescribed order and replace any parts not performing according to specifications.

It is important to resume all tests when replacing a component.

If not specified, the probe connecting sequence is not important.

Section 06 ELECTRICAL
Subsection 06 (TESTING PROCEDURE)

LIGHTING SYSTEM TESTING (S-Series with RER 240 W)								
PART	TEST TO BE PERFORMED	WIRE COLOR	MULTIMETER PROBE CONNECTION	RESISTANCE Ω		VOLTAGE V		NOTE
				VALUE (OHMS)	MULTIMETER SCALE	VALUE (VOLTS)	MULTIMETER SCALE	
Lighting generator coil	Power	YL YL/BK	2-01B-F 2-01A-F	00.0 - 00.6	00.0 Ω	3.0 - 7.0	00.0 ^{VAC}	—
	Insulation	YL engine	2-01(A,B)-F engine	0.L	00.0 $M\Omega$	—	—	The term "engine" refers to the engine metal parts connected to the magneto housing.
	Ground continuity	BK engine	2-01C-F engine	00.0 - 00.5	00.0 Ω	—	—	

NOTE: It is important to take note that voltage measurements must be taken while starting the vehicle using the manual starter.

Voltages obtained upon starting are proportional to the force applied onto the manual starter. A low voltage is therefore normal under a low cranking force.

Perform testing in the prescribed order and replace any parts not performing according to specifications.

It is important to resume all tests when replacing a component.

If not specified, the probe connecting sequence is not important.

Section 06 ELECTRICAL

Subsection 06 (TESTING PROCEDURE)

DUCATI TRIGGER COIL CDI SYSTEM TESTING

Formula S, MX Z 440 and Skandic WT/SWT

IGNITION SYSTEM TESTING SEQUENCE

In case of ignition problems, check the following in the prescribed order until the problem can be solved.

1. Sparking/spark plug condition.
2. Electrical connectors.
3. Ignition switches, tether cord cap and emergency switch.
4. Ignition coil output.
5. Trigger coil output.

LIGHTING SYSTEM TESTING SEQUENCE

1. Electrical connectors.
2. Magneto output (lighting generator coil).

Testing Conditions

Voltage measurements are always taken upon starting the vehicle. Readings taken when the engine is running will be higher than indicated range. Part temperature must be approximately 20°C (68°F) (room temperature), otherwise readings could be distorted.

Analysis of Readings

Voltage Readings

When testing the different magneto components, it is important to take into consideration that readings vary according to the force applied onto the manual starter. It is therefore important to employ enough force upon each trial.

The reading must be 3 times within or above the range indicated in the corresponding table. If the reading is too low, the part is considered to be defective and it must be replaced.

Resistance Readings

Place multimeter selector switch to Ω in order to measure resistance. Readings must be within the indicated range. Otherwise, the part is considered to be defective and must be replaced.

CAUTION: When taking measurements, it is useless to try to start the vehicle since readings would then be distorted.

Intermittent Ignition Problems

It is difficult to make a diagnostic in the case of intermittent ignition problems. Thus, problems occurring only when the engine operating temperature is normal must be checked in similar conditions.

In most cases when problems are caused by temperature or vibrations, these can only be solved by replacing parts. Most problems cannot be detected when the engine is stopped.

Multiple Problems

As a matter of fact, more than one component can be defective. As a result, if the problem remains although a part was replaced, start over the whole verification from the beginning in order to identify the other defective component.

1. SPARKING

During this operation, it is important to use the snowmobile spark plug and not a new one. Bring the plug in contact with the engine. If no spark is produced, replace the spark plug with a new one and do the test again.

2. ELECTRICAL CONNECTOR TESTING

Make sure that none of the connectors are disconnected.

3. IGNITION SWITCH, TETHER CORD SWITCH AND EMERGENCY SWITCH TESTING

Disconnect connector housing 2-01 from engine, and using a multimeter, check resistance as indicated in IGNITION table.



If readings are acceptable, go on to next step.

If readings are inadequate, individually check each switch as follows.

Ignition Switch (key)

Disconnect switch housing. Using a multimeter, check between **MAG** and **GRD** terminals if the circuit is open ($0.L_{M\Omega}$) in operating position and if the circuit is closed (0_{Ω}) in off position.



TYPICAL

If readings do not correspond to the above-mentioned indications, replace switch.

If readings are acceptable, check other switches.

Emergency Switch

Unplug switch block connected to main wiring harness. Check using a multimeter. Connect probes to 6-02-C-M and 6-02-D-M terminals. The multimeter should indicate an open circuit ($0.L_{M\Omega}$) in operating position and a closed circuit (0_{Ω}) in off position.



TYPICAL

If readings do not correspond to the above-mentioned indications, replace switch.

If readings are acceptable, check other switches.

Section 06 ELECTRICAL

Subsection 06 (TESTING PROCEDURE)

Tether Cord Switch

Unplug switch block connected to main wiring harness. Check using a multimeter by connecting probes to 6-03-B-M and 6-03-A-M wires. The multimeter should indicate an open circuit ($0.L_{M\Omega}$) in operating position and a closed circuit (0_{Ω}) in off position.



A05E09A

TYPICAL

If readings do not correspond to the above-mentioned indications, replace switch.

If readings are acceptable, check other switches. If none of these verifications are conclusive, the problem finds its source in the main wiring harness. Proceed as follows:

NOTE: For this next step, no stop switch must be connected to the main wiring harness.

Disconnect all stop switches from the main wiring harness and check the continuity of each wire by connecting probes to the end of wires of the same color. Repeat with all other wires. It is important to mention that all wires of the same color within a given harness are connected together. These wires should therefore have a closed circuit. On the other hand, BLACK and BLACK/YELLOW wires must have an open circuit ($0.L_{M\Omega}$).

Repair or replace if necessary.

4. IGNITION GENERATOR COIL VOLTAGE TESTING

General

When manually starting the engine while the spark plug is installed, the engine will tend to accelerate beyond the compression point. This will result in higher magneto output power.

1. Disconnect the 4-wire housing between the ignition module and the magneto wiring harness (4-02).
2. Connect multimeter probes to GREEN and WHITE wires (female end), then bring selector to \checkmark and scale to 00.0^{VAC} .
3. Activate the manual starter and check values indicated by the multimeter.
4. Repeat operation 3 times.



A03E1JA

5. Compare readings with those appearing in the IGNITION table.

5. TRIGGER COIL VOLTAGE TESTING

1. Disconnect 4-wire housing between the ignition module and the engine (4-02).
2. Connect multimeter probes to RED/WHITE wire (female side) and to the engine, then bring selector switch to \checkmark and scale to 00.0^{VAC} .
3. Activate the manual starter and check values indicated by the multimeter.
4. Repeat operation 3 times.
5. Compare readings with those appearing in the IGNITION table.

CONCLUSION

If none of the above testing operations produced valid results, it is strongly recommended to keep on testing according to the list appearing in the Resistance column of the IGNITION table.

Set the multimeter as indicated.

LIGHTING GENERATOR COIL VOLTAGE TESTING

NOTE: The lighting generator coil is not part of the ignition system. It is a self-contained system used to supply current to the lighting system and to other devices working on alternating current. However, this system can be tested using a multimeter.

1. Disconnect housing from engine (2-01).
2. Connect multimeter wires to YELLOW and YELLOW/BLACK wires (female side), then place selector switch to \checkmark and scale to 0.00^{VAC}.
3. Activate the manual starter and check values indicated by the multimeter.
4. Repeat operation 3 times.



5. Compare readings with those appearing in the LIGHTING table.

CONCLUSION

If none of the above testing operations produced valid results, it is strongly recommended to keep on testing according to the list appearing in the Resistance column of the LIGHTING table.

Set the multimeter as indicated.

Section 06 ELECTRICAL

Subsection 06 (TESTING PROCEDURE)

IGNITION SYSTEM TESTING (Formula S, MX Z 440 and Skandic WT/SWT)								
PART	TEST TO BE PERFORMED	WIRE COLOR	MULTIMETER PROBE CONNECTION	RESISTANCE Ω		VOLTAGE V		NOTE
				VALUE (OHMS)	MULTIMETER SCALE	VALUE (VOLTS)	MULTIMETER SCALE	
Stop switch	Running insulation	BK and BK/YL	2-01-D-M and 2-01-C-M	0.L	00.0 $M\Omega$	—	—	No stop switch must be operational.
	Continuity in stop position	BK and BK/YL	2-01-D-M and 2-01-C-M	00.0 - 00.5	00.0 Ω	—	—	At least one stop switch must be operational.
Ignition generator coil	Output	WH and GN	4-02-B-F and 4-02-A-FA	230.0 - 330.0	00.0 Ω	30.0 - 60.0	00.0 ^{VAC}	No stop switch must be operational.
	Ground continuity	WH and engine	4-02-B-F and engine	00.0 - 00.5	00.0 Ω	—	—	The term "engine" refers to the engine metal parts connected to the magneto housing.
Trigger coil	Continuity	RD/WH and engine	4-02-D-F and engine	140.0 - 180.0	00.0 Ω	2.0 - 9.0	00.0 ^{VAC}	
Ignition module and high voltage coil	Secondary winding resistance with caps	—	Spark plug cap and on the engine	13.1 K - 18.3 K	00.0 $K\Omega$	CAUTION: Do not measure high voltage coil output voltage.		
High voltage coil	Secondary winding resistance with caps	Spark plug cap	In spark plug cap	8.90 K - 13.1 K	00.0 $K\Omega$	CAUTION: Do not measure high voltage coil output voltage.		
	Secondary winding resistance without caps	BK BK	Inside spark plug cable	0.90 K - 1.10 K	00.0 $K\Omega$	CAUTION: Do not measure high voltage coil output voltage.		
	Secondary winding voltage	BK engine	On spark plug cable housing and on the engine	—	—	.100 - .250	0.00 ^{VAC}	The measurement must be taken on the spark plug cable (without the spark plug).
Spark plug cap	Cap resistance	—	Spark plug side and cable side	4.0 K - 6.0 K	00.0 $K\Omega$	—	—	—

M: Male
F: Female

NOTE: Stop switches include the ignition switch, the tether cord switch and the emergency cut-out switch.

It is important to take note that voltage measurements must be taken while starting the vehicle using the manual starter.

Voltages obtained upon starting are proportional to the force applied onto the manual starter. A low voltage is therefore normal under a low cranking force.

Perform testing in the prescribed order and replace any parts not performing according to specifications.

It is important to resume all tests when replacing a component.

If not specified, the probe connecting sequence is not important.

Section 06 ELECTRICAL
Subsection 06 (TESTING PROCEDURE)

LIGHTING SYSTEM TESTING (Formula S, MX Z 440 and Skandic WT/SWT)								
PART	TEST TO BE PERFORMED	WIRE COLOR	MULTIMETER PROBE CONNECTION	RESISTANCE Ω		VOLTAGE V		NOTE
				VALUE (OHMS)	MULTIMETER SCALE	VALUE (VOLTS)	MULTIMETER SCALE	
Lighting generator coil	Power	YL and YL/BK	2-01-B-F and 2-01-A-F	0.05 - 0.6	00.0 Ω	2.5 - 7.0	00.0 ^{VAC}	—
	Insulation	YL and engine	2-01 (A,B)-F and engine	0.L	00.0 _M Ω	—	—	—
	Ground continuity	BK engine	2-01-C-F and engine	00.0 - 00.5	00.0 _M Ω	—	—	—

M: Male
F: Female

NOTE: Stop switches include the ignition switch, the tether cord switch and the emergency cut-out switch.

It is important to take note that voltage measurements must be taken while starting the vehicle using the manual starter.

Voltages obtained upon starting are proportional to the force applied onto the manual starter. A low voltage is therefore normal under a low cranking force.

Perform testing in the prescribed order and replace any parts not performing according to specifications.

It is important to resume all tests when replacing a component.

If not specified, the probe connecting sequence is not important.

Section 06 ELECTRICAL

Subsection 06 (TESTING PROCEDURE)

NIPPONDENSO CDI SYSTEM TESTING

S-Series Liquid Cooled Models and Skandic WT LC

IGNITION SYSTEM TESTING SEQUENCE

In the case of ignition problems, check the following in the prescribed order until the problem can be solved.

1. Sparking/spark plug condition.
2. Electrical connectors.
3. Ignition switches, tether cord cap switch and emergency switch.
4. Ignition coil output.
5. Ignition module output.

LIGHTING SYSTEM TESTING SEQUENCE

1. Electrical connectors.
2. Magneto output (lighting generator coil).

Testing Conditions

Voltage measurements are always taken upon vehicle starting. Readings when the engine is running will be higher than indicated range. Part temperature must be approximately 20°C (68°F) (room temperature), otherwise readings could be distorted.

Analysis of Readings

Voltage Readings

When testing the different magneto components, it is important to take into consideration that readings vary according to the force applied onto the manual starter. It is therefore important to employ enough force upon each trial.

The reading must be 3 times within or above the range indicated in the corresponding table. If the reading is too low, the part is considered to be defective and must be replaced.

Resistance Readings

Place multimeter selector switch to Ω in order to measure resistance. Readings must be within the indicated range. Otherwise, the part is considered to be defective and must be replaced.

CAUTION: When taking measurements, it is useless to try to start the vehicle since readings would then be distorted.

Intermittent Ignition Problems

It is difficult to make a diagnostic in the case of intermittent ignition problems. Thus, problems occurring only when the engine operating temperature is normal must be checked in similar conditions.

In most cases when problems are caused by temperature or vibrations, these can only be solved by replacing parts. Most problems cannot be detected when the engine is stopped.

Multiple Problems

As a matter of fact, more than one component can be defective. As a result, if the problem remains although a part was replaced, start over the whole verification from the beginning in order to identify the other defective component.

1. SPARKING

During this operation, it is important to use the snowmobile spark plug and not a new one. Bring the plug in contact with the engine. If no spark is produced, replace the spark plug with a new one and do the test again.

2. ELECTRICAL CONNECTOR TESTING

Make sure that none of the connectors are disconnected.

3. IGNITION SWITCH, TETHER CORD SWITCH AND EMERGENCY SWITCH TESTING

Disconnect connector housing from engine and check resistance as indicated in IGNITION table.

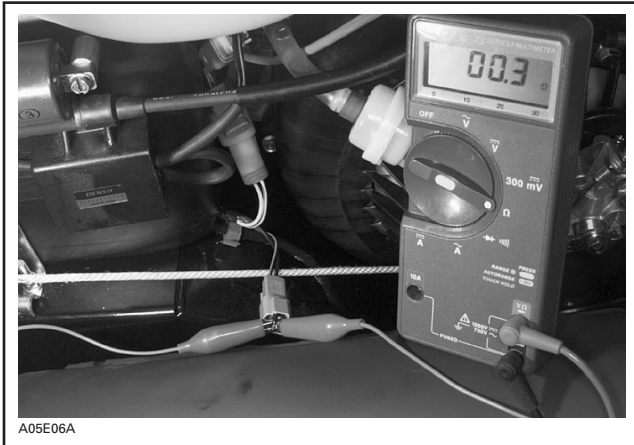

A05E06A

TYPICAL

If readings are acceptable, go on to next step.

If readings are inadequate, individually check each switch as follows.

Ignition Switch (key)

Disconnect switch housing. Using a multimeter, check between **MAG** and **GRD** terminals if the circuit is open ($0.L_{M\Omega}$) in operating position and if the circuit is closed (0_{Ω}) in off position.



A05E07A

TYPICAL

If readings do not correspond to the above-mentioned indications, replace switch.

If readings are acceptable, check other switches.

Emergency Switch

Unplug switch block connected to main wiring harness. Check using a multimeter. Connect probes to **BLACK/YELLOW** and **BLACK** wires. The multimeter should indicate an open circuit ($0.L_{M\Omega}$) in operating position and a closed circuit (0_{Ω}) in off position.



A05E08A

TYPICAL

If readings do not correspond to the above-mentioned indications, replace switch.

If readings are acceptable, check other switches.

Section 06 ELECTRICAL

Subsection 06 (TESTING PROCEDURE)

Tether Cord Switch

Unplug switch block connected to main wiring harness. Check using a multimeter by connecting probes to BLACK/YELLOW and BLACK wires. The multimeter should indicate an open circuit ($0.L_{M\Omega}$) in operating position and a closed circuit (0_{Ω}) in off position.



A05E09A

TYPICAL

If readings do not correspond to the above-mentioned indications, replace switch.

If readings are acceptable, check other switches.

If none of these verifications are conclusive, the problem finds its source in the main wiring harness. Proceed as follows:

NOTE: For the next step, no switch must be connected to the main wiring harness.

Disconnect all switches from the main wiring harness and check the continuity of each wire by connecting probes to the end of wires of the same color. Repeat with all other wires. It is important to mention that all wires of the same color within a given harness are connected together. These wires should therefore have a closed circuit. On the other hand, BLACK and BLACK/YELLOW wires must have an open circuit ($0.L_{M\Omega}$).

Repair or replace if necessary.

4. IGNITION GENERATOR COIL VOLTAGE TESTING

General

When manually starting the engine while the spark plug is installed, the engine will tend to accelerate beyond the compression point. This will result in higher magneto output power.

1. Disconnect the 3-wire housing between the ignition module and the magneto wiring harness.
2. Connect multimeter probes to BLACK and BLACK/RED wires and bring the selector switch to \checkmark and the scale to 00.0^{VAC} .
3. Activate the manual starter and check values indicated by the multimeter.
4. Repeat operation 3 times.
5. Compare readings with those appearing in the IGNITION table.

5. IGNITION MODULE VOLTAGE TESTING

1. Disconnect the 2-wire connector between module and high voltage coil.
2. Connect multimeter probes to module. Place the selector switch to \checkmark and the scale to 00.0^{VAC} .
3. Activate the manual starter and check values indicated by the multimeter.
4. Repeat operation 3 times.



A05E0CA

5. Compare readings with those appearing in the IGNITION table.

CONCLUSION

If none of the above testing operations produced valid results, it is strongly recommended to keep on testing according to the list appearing in the Resistance column of the IGNITION table.

Set the multimeter as indicated.

LIGHTING GENERATOR COIL VOLTAGE TESTING

NOTE: The lighting generator coil is not part of the ignition system. It is a self-contained system used to supply current to the lighting system and to other devices working on alternating current. However, this system can be tested using a multimeter.

1. Disconnect housing from engine (YELLOW, YELLOW and BLACK wires).
2. Connect multimeter probes to YELLOW wires, then place selector switch to \checkmark and scale to 0.00^{VAC}.
3. Activate the manual starter and check values indicated by the multimeter.
4. Repeat operation 3 times.

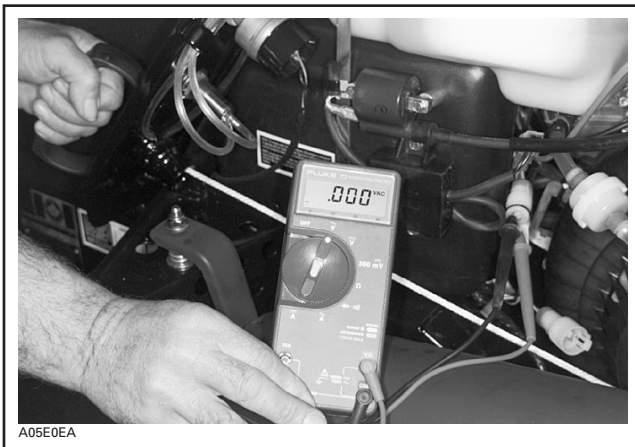

5. Compare readings with those appearing in the LIGHTING table.

CONCLUSION

If none of the above testing operations produced valid results, it is strongly recommended to keep on testing according to the list appearing in the Resistance column of the LIGHTING table.

Set the multimeter as indicated.

Section 06 ELECTRICAL

Subsection 06 (TESTING PROCEDURE)

IGNITION SYSTEM TESTING (S-Series liquid cooled models and Skandic WT LC)								
PART	TEST TO BE PERFORMED	WIRE COLOR	MULTIMETER PROBE CONNECTION	RESISTANCE Ω		VOLTAGE V		NOTE
				VALUE (OHMS)	MULTIMETER SCALE	VALUE (VOLTS)	MULTIMETER SCALE	
Emergency stop switch	Running insulation	BK and BK/YL	2-01A-F and 2-02-M	0.L	00.0 _M Ω	—	—	No stop switch must be operational.
	Continuity in stop position	BK and BK/YL	2-01A-F and 2-02-M	00.0 - 00.5	00.0 _{Ω}	—	—	At least one stop switch must be operational.
DESS stop switch	Insulation in stop position	BK/GN BK/WH	6-03B-M 6-03C-M	0.L	00.0 _M Ω	—	—	Tether cord cap must be removed.
	Continuity in running position	BK/GN BK/WH	6-03B-M 6-03C-M	00.0 - 00.5	00.0 _{Ω}	—	—	Tether cord cap must be in place.
Ignition generator coil	Output	RD BK/RD	2-05A-F and 2-05B-F	10.0 - 15.0	00.0 _{Ω}	10.0 - 13.5	00.0 ^{VAC}	No stop switch must be operational.
	Coil insulation	BK BK/RD	2-05C-F and 2-05B-F	0.L	00.0 _{Ω}	—	—	
		BK RD	2-05A-F and 2-04A-F	0.L	00.0 _{Ω}	—	—	
	Ground continuity	BK and engine	2-05C-1-F and 2-01A-F	00.0 - 00.5	00.0 _{Ω}	—	—	—
	Ground continuity	BK and engine	2-01A-F and engine	00.0 - 00.5	00.0 _{Ω}	—	—	The term "engine" refers to the engine metal parts connected to the magneto housing.
Trigger coil	Resistance and output	WH/YL and BL/YL	2-03-2 2-03-1 On DESS equipped vehicles: 2-02-1 2-02-2	190 - 270	00.0 _{Ω}	.200 - 350	.000 ^{VAC}	—
Ignition module	Output voltage	BK and WH/BL	3-01-1-F and 3-01-2-F	—	—	4.5 - 8.0	00.0 ^{VAC}	—

Section 06 ELECTRICAL
Subsection 06 (TESTING PROCEDURE)

IGNITION SYSTEM TESTING (S-Series liquid cooled models and Skandic WT LC)								
PART	TEST TO BE PERFORMED	WIRE COLOR	MULTIMETER PROBE CONNECTION	RESISTANCE Ω		VOLTAGE V		NOTE
				VALUE (OHMS)	MULTIMETER SCALE	VALUE (VOLTS)	MULTIMETER SCALE	
High voltage coil	Primary winding resistance	BK and WH/BL	3-01-1-M and 3-01-2-M	0.00 - 00.9	00.0 Ω	—	—	Disconnect WH/BL wire from coil in order to take measurements.
	Secondary winding resistance (spark plug cap included)	—	In spark plug caps	11.5 K - 14.5 K	00.0 $K\Omega$	CAUTION: Do not measure high voltage coil output voltage.		
	Secondary winding resistance	—	On spark plug wires	19.5 K - 26.5 K	00.0 $K\Omega$	CAUTION: Do not measure high voltage coil output voltage.		
	Secondary winding voltage	—	On spark plug wire and engine	—	—	0.1 - 1.4	0.00 ^{VAC}	The measurement must be taken on the spark plug wire (without the spark plug).
	Insulation	Cap and WH/BL	Cap and BK	In cap and 3-01-2-M	0.L	00.0 Ω	—	—
In cap and 3-01-1-M				0.L	00.0 Ω	—	—	
Spark plug cap	Cap resistance	—	Spark plug side and wire side	4.0 K - 6.0 K	00.0 $K\Omega$	—	—	—

M: Male
F: Female

NOTE: Stop switches include the ignition switch, the tether cord switch and the emergency cut-out switch.

It is important to take note that voltage measurements must be taken while starting the vehicle using the manual starter.

Voltages obtained upon starting are proportional to the force applied onto the manual starter. A low voltage is therefore normal under a low cranking force.

Perform testing in the prescribed order and replace any parts not performing according to specifications.

It is important to resume all tests when replacing a component.

If not specified, the probe connecting sequence is not important.

Section 06 ELECTRICAL

Subsection 06 (TESTING PROCEDURE)

LIGHTING SYSTEM TESTING (S-Series liquid cooled models and Skandic WT LC)								
PART	TEST TO BE PERFORMED	WIRE COLOR	MULTIMETER PROBE CONNECTION	RESISTANCE Ω		VOLTAGE V		NOTE
				VALUE (OHMS)	MULTIMETER SCALE	VALUE (VOLTS)	MULTIMETER SCALE	
Lighting generator coil	Power	YL and YL	2-01A-F and 2-01B-F	0.05 - 0.6	00.0 Ω	3.0 - 7.0	00.0 ^{VAC}	—
	Insulation	YL and engine	2-01A-F and engine	0.L	00.0 $M\Omega$	—	—	—
		YL and engine	2-01B-F and engine	0.L	00.0 $M\Omega$	—	—	—

M: Male
F: Female

NOTE: Stop switches include the ignition switch, the tether cord switch and the emergency cut-out switch.

It is important to take note that voltage measurements must be taken while starting the vehicle using the manual starter.

Voltages obtained upon starting are proportional to the force applied onto the manual starter. A low voltage is therefore normal under a low cranking force.

Perform testing in the prescribed order and replace any parts not performing according to specifications.

It is important to resume all tests when replacing a component.

If not specified, the probe connecting sequence is not important.

INSPECTION OF AC CIRCUIT ISOLATION

All Electric Start Models

If AC circuit is not isolated from frame, headlamp beam will weaken.

INSPECTION

Disconnect regulator/rectifier.

Connect one digital ohmmeter probe (needle ohmmeter will not offer enough precision) to frame and other probe to one of 2 YELLOW magneto wires.

Measured resistance must be infinite. If such is not the case, it means there is a connection between AC circuit and DC circuit.

Disconnect one accessory at the time to identify the faulty circuit.

Section 06 ELECTRICAL

Subsection 06 (TESTING PROCEDURE)

INSPECTION OF HEATING ELEMENTS

All Models Except Skandic WT/SWT/WT LC

All measurements must be performed at 21°C (70°F).

Throttle Lever Heating Element

Resistance Measurement

HIGH INTENSITY	YELLOW/BLACK wire BROWN wire	1.96 to 3.64 ohms
LOW INTENSITY	YELLOW/BLACK wire BROWN/YELLOW wire	8.05 to 14.95 ohms

Current Measurement

HIGH INTENSITY	BROWN wire	0.23 A minimum
LOW INTENSITY	BROWN/YELLOW wire	0.13 A minimum

Handlebar Grip Heating Element

Resistance Measurement

HIGH INTENSITY	YELLOW/BLACK wire ORANGE wire	8.73 to ① 10.67 ohms
LOW INTENSITY	YELLOW/BLACK wire ORANGE/VIOLET wire	17.7 to ① 20.7 ohms

Skandic WT/SWT/WT LC

Throttle Lever Heating Element

Resistance Measurement

BLACK wire BLACK wire	48 ohms
--------------------------	---------

Handlebar Grip Heating Element

Resistance Measurement

BLACK wire BLACK wire	9.6 ohms ①
--------------------------	------------

① When measuring resistance at terminals the actual value will be half the measurement in table. The reason for that is the elements are connected in parallel. Therefore the total resistance is half the resistance of one element.