

# TABLE OF CONTENTS

<b>ENGINE REMOVAL AND INSTALLATION</b> .....	<b>04-02-1</b>
REMOVAL FROM VEHICLE .....	04-02-2
ENGINE AND MUFFLER DISASSEMBLY AND ASSEMBLY.....	04-02-2
INSTALLATION ON VEHICLE.....	04-02-2
<b>VALVE ADJUSTMENT</b> .....	<b>04-03-1</b>
VALVE ADJUSTMENT .....	04-03-2
<b>DISASSEMBLY/ASSEMBLY</b> .....	<b>04-04-1</b>
<b>TOP END</b> .....	<b>04-04-1</b>
TOP END REMOVAL.....	04-04-2
CLEANING .....	04-04-2
DISASSEMBLY.....	04-04-2
INSPECTION .....	04-04-3
ASSEMBLY.....	04-04-3
TOP END INSTALLATION.....	04-04-4
<b>BOTTOM END</b> .....	<b>04-04-5</b>
CLEANING .....	04-04-6
DISASSEMBLY.....	04-04-6
INSPECTION .....	04-04-8
ASSEMBLY.....	04-04-8
<b>COMPRESSION TEST AND ENGINE DIMENSION MEASUREMENT</b> .....	<b>04-05-1</b>
<b>COMPRESSION TEST</b> .....	<b>04-05-1</b>
<b>ENGINE DIMENSION MEASUREMENT</b> .....	<b>04-05-2</b>
VALVE SPRING FREE LENGTH .....	04-05-2
VALVE SEAT WIDTH .....	04-05-2
VALVE STEM (outside diameter) .....	04-05-2
VALVE GUIDE (inside diameter) .....	04-05-2
GUIDE-TO-STEM CLEARANCE.....	04-05-3
CYLINDER HEAD SURFACE .....	04-05-3
CYLINDER INSIDE DIAMETER.....	04-05-3
USED PISTON MEASUREMENT .....	04-05-3
CYLINDER/PISTON CLEARANCE .....	04-05-4
RING/PISTON GROOVE CLEARANCE.....	04-05-5
RING END GAP .....	04-05-5
CONNECTING ROD BIG END SIDE CLEARANCE.....	04-05-5
PISTON PIN (outside diameter).....	04-05-6
PISTON PIN BORE (inside diameter) .....	04-05-6
PISTON-TO-PISTON PIN BORE CLEARANCE.....	04-05-6
CONNECTING ROD SMALL END (inside diameter) .....	04-05-6
CONNECTING ROD BIG END (inside diameter).....	04-05-6

---

## Section 04 ENGINE

### Subsection 01 (TABLE OF CONTENTS)

---

CONNECTING ROD BIG END OIL CLEARANCE.....	04-05-7
CRANKPIN (outside diameter).....	04-05-8
CAMSHAFT CAM HEIGHT.....	04-05-8
CAMSHAFT (outside diameter).....	04-05-8
CAMSHAFT HOLDER (inside diameter).....	04-05-9
CHECKING SURFACE FLATNESS.....	04-05-9
RECTIFYING SURFACES.....	04-05-9
<hr/>	
<b>TRANSISTORIZED MAGNETO IGNITION.....</b>	<b>04-06-1</b>
CLEANING.....	04-06-2
DISASSEMBLY.....	04-06-2
INSPECTION.....	04-06-2
ASSEMBLY.....	04-06-3
<hr/>	
<b>REWIND STARTER.....</b>	<b>04-07-1</b>
REMOVAL.....	04-07-2
DISASSEMBLY.....	04-07-2
INSPECTION.....	04-07-3
ASSEMBLY.....	04-07-3
INSTALLATION.....	04-07-5
<hr/>	
<b>CARBURETOR.....</b>	<b>04-08-1</b>
REMOVAL.....	04-08-2
CLEANING AND INSPECTION.....	04-08-4
DISASSEMBLY AND ASSEMBLY.....	04-08-4
CARBURETOR FLOAT LEVEL.....	04-08-6
INSTALLATION.....	04-08-6
CARBURETOR ADJUSTMENTS.....	04-08-7
GOVERNOR ADJUSTMENT.....	04-08-7
<hr/>	
<b>FUEL TANK AND THROTTLE CABLE.....</b>	<b>04-09-1</b>

# ENGINE REMOVAL AND INSTALLATION

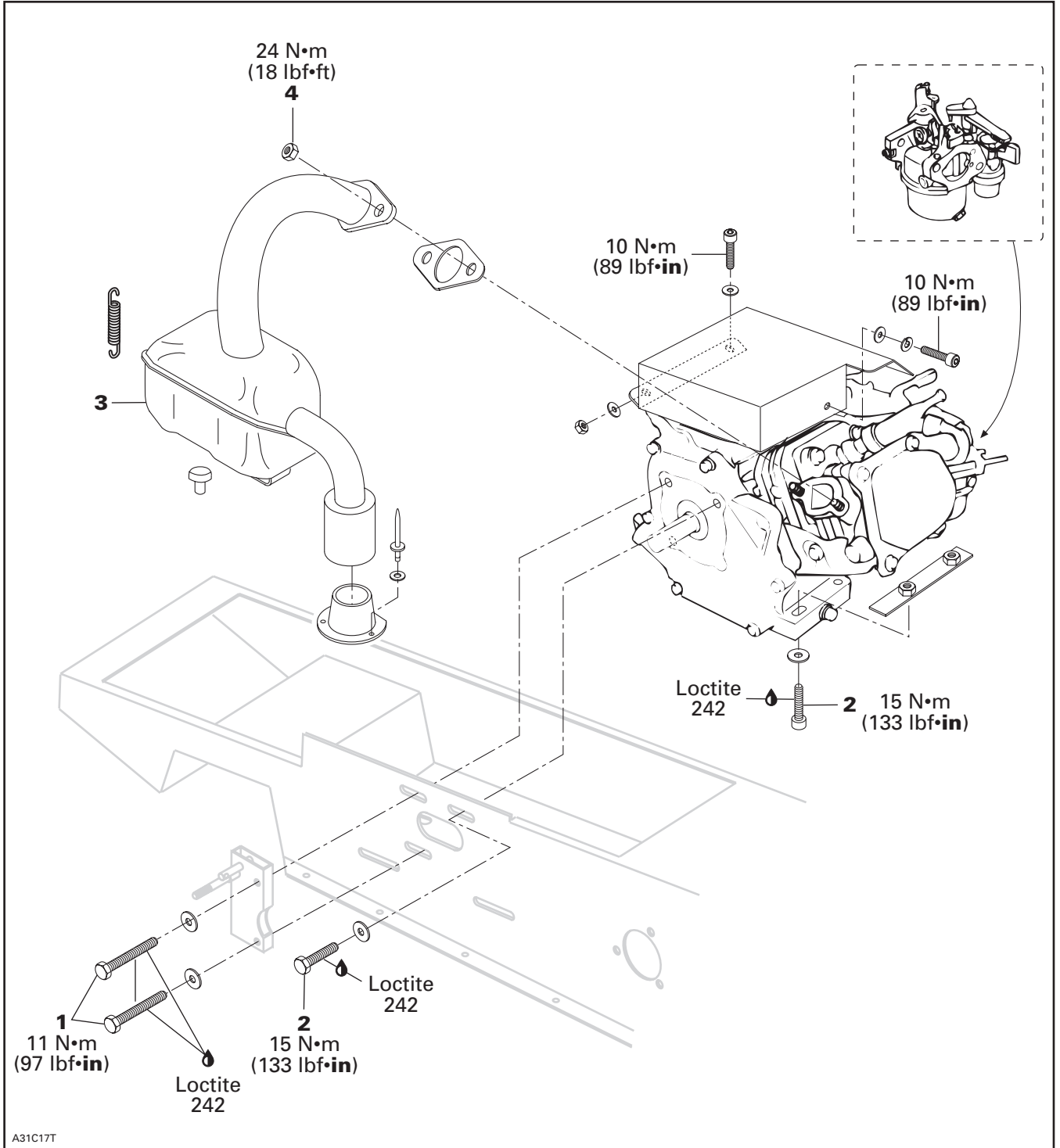

---

## Section 04 ENGINE

### Subsection 02 (ENGINE REMOVAL AND INSTALLATION)

---

#### REMOVAL FROM VEHICLE

Remove or disconnect the following then lift engine from vehicle:

- chain guard
- drive chain
- drive sprocket (clutch)
- muffler **no. 3**
- engine protector **no. 5**
- throttle cable
- choke cable
- fuel line
- electrical connectors
- engine mount screws **no. 2**
- brake support screws **no. 1**

#### ENGINE AND MUFFLER DISASSEMBLY AND ASSEMBLY

Torque the muffler nuts **no. 4** to 24 N•m (18 lbf•ft).

Torque both brake support screws **no. 1** to 11 N•m (97 lbf•in) and 5 engine mount screws **no. 2** to 15 N•m (133 lbf•in).

#### INSTALLATION ON VEHICLE

To install engine on vehicle, reverse removal procedure. However, pay attention to the following:

- Check tightness of engine mount screws, and clutch screw.
- After throttle cable and choke installation, check for proper operation.
- Check drive chain automatic tensioner for proper operation.



# VALVE ADJUSTMENT

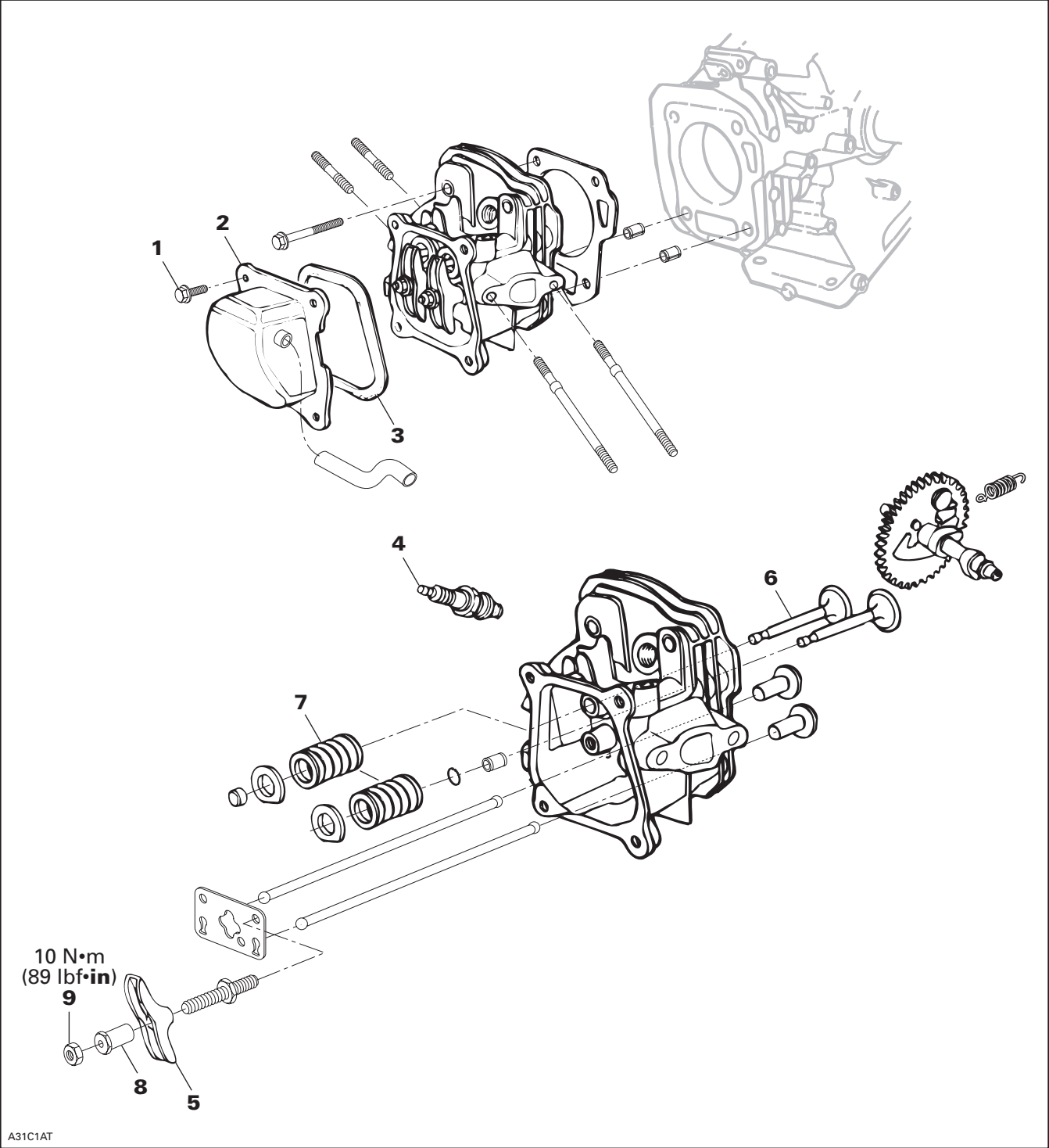

## Section 04 ENGINE

### Subsection 03 (VALVE ADJUSTMENT)

## VALVE ADJUSTMENT

**NOTE:** Valve clearance inspection and adjustment must be performed with the engine cold.

### Preparation

Remove cylinder head cover bolts **no. 1**, cylinder head cover **no. 2** and gasket **no. 3**.

Set the piston at TDC (Top Dead Center) of the **compression** stroke, as shown in the following procedure.

### COMPRESSION STROKE TDC POSITIONING

Remove spark plug **no. 4**.

Turn engine clockwise (PTO side) by hand so that triangular mark on starter pulley align with the top hole on the fan cover.

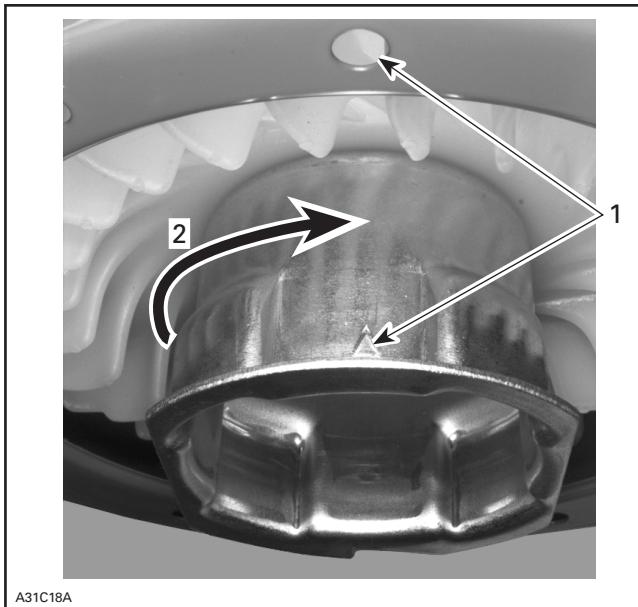

A31C18A

#### REWIND STARTER HAS BEEN REMOVED

1. Triangular mark aligned with fan cover top hole
2. Rotate clockwise to position engine at TDC of compression stroke

**CAUTION:** The triangular mark on the starter pulley will align with the top hole on the fan cover when the piston is at top dead center of the compression or exhaust stroke. Ensure that piston is at TDC of the **compression** stroke. At compression stroke both valves are fully closed.

## Valve Clearance Inspection

Insert a feeler gauge between rocker arm **no. 5** and valve **no. 6**. Refer to the following table for valve clearance.

STANDARD VALVE CLEARANCE	
Intake valve	0.15 ± 0.02 mm (0.006 ± 0.001 in)
Exhaust valve	0.20 ± 0.02 mm (0.008 ± 0.001 in)

**NOTE:** When inspecting clearance, ensure that feeler gauge does not compress valve springs **no. 7**. Valve springs have low compression rates.

If valve clearance is not according to the above table, perform valve clearance adjustment as described in the following procedure.

## Valve Clearance Adjustment

Hold rocker arm pivot **no. 8** and loosen rocker arm pivot lock nut **no. 9**, as shown in the next photo.

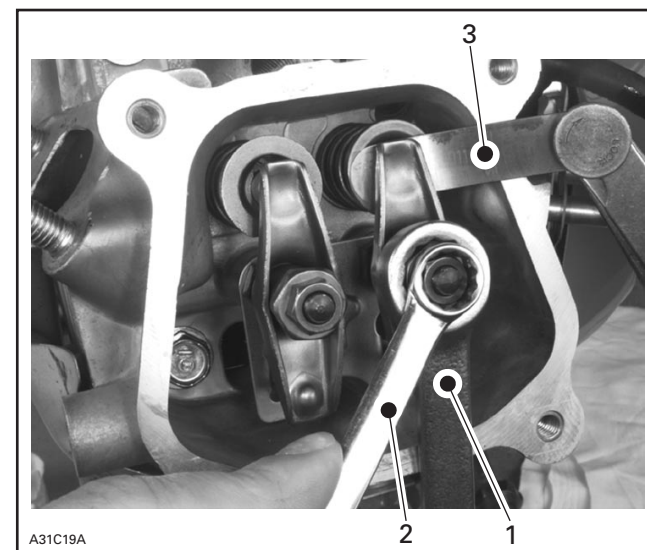

A31C19A

1. Tool retaining rocker arm pivot
2. Tool loosening lock nut of rocker arm pivot
3. Feeler gauge

Turn rocker arm pivot to obtain the specified clearance.

Retighten the rocker arm pivot lock nut while holding the rocker arm pivot.

Recheck valve clearance after tightening the rocker arm pivot lock nut.

Reinstall cylinder head cover with gasket then secure with cylinder head cover bolts tightened in a crisscross sequence.

# DISASSEMBLY/ASSEMBLY

## TOP END

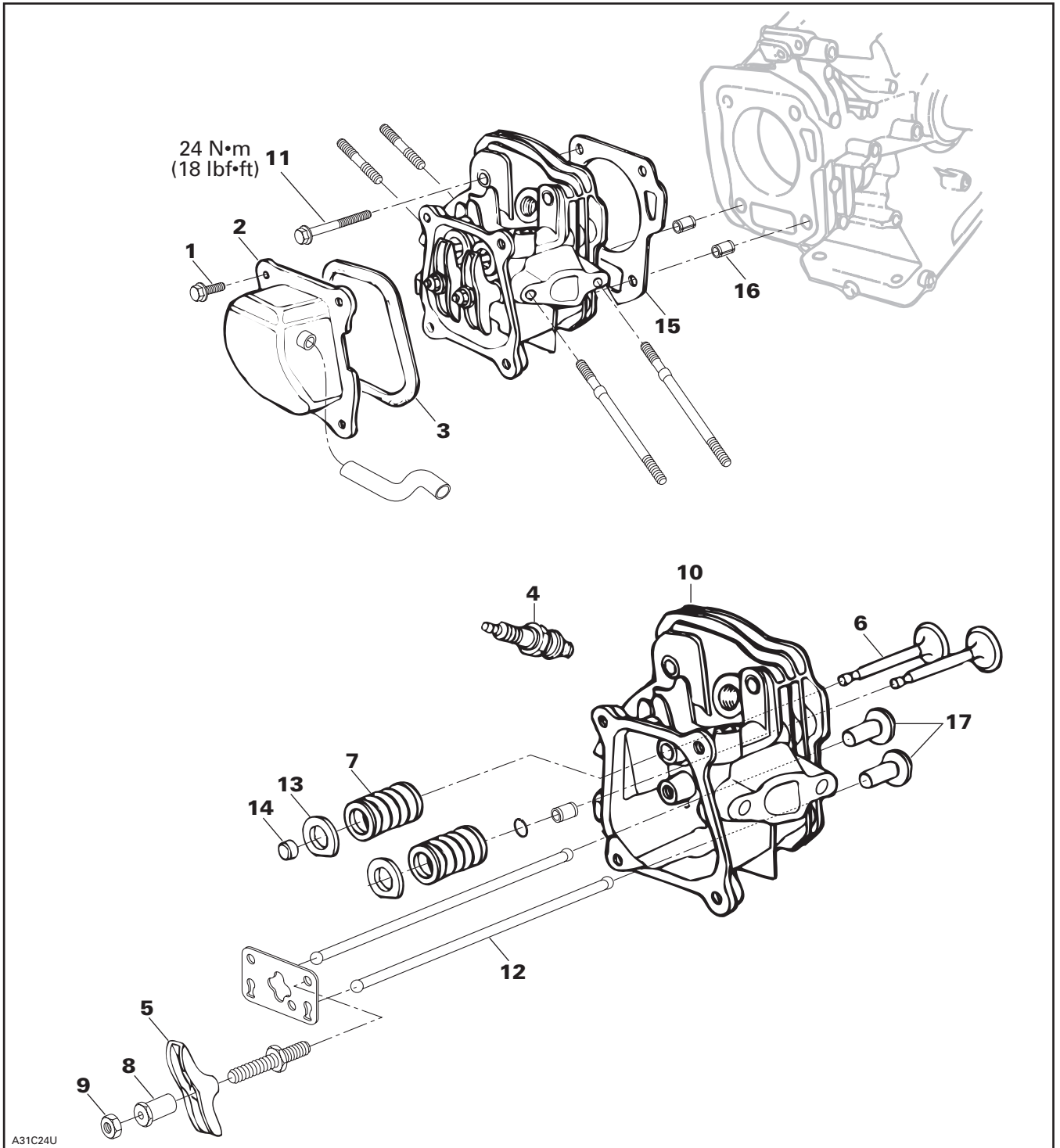

## Section 04 ENGINE

### Subsection 04 (DISASSEMBLY/ASSEMBLY)

## TOP END REMOVAL

Remove the following then lift cylinder head no. 10:

- carburetor
- exhaust system
- spark plug no. 4
- cylinder head cover no. 2
- cylinder head nuts no. 11

**NOTE:** When removing cylinder head, mark both push rods no. 12 for reassembly.

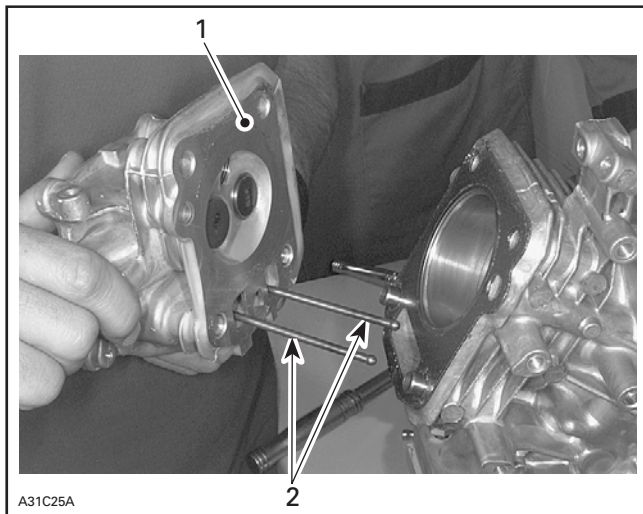

**TYPICAL — MECHANIC REMOVING CYLINDER HEAD**

1. Cylinder head
2. Mark both push rods for reassembly

Pull out push rods.

## CLEANING

Discard all gaskets.

Clean all metal components in a non-ferrous metal cleaner.

Scrape off carbon formation from cylinder exhaust port, cylinder head, valves no. 6 and piston dome using a wooden spatula.

**NOTE:** The triangular mark on the piston dome must be visible after cleaning.

Clean the piston ring grooves with a groove cleaner tool, or with a piece of broken ring.

## DISASSEMBLY

**NOTE:** Before disassembling, mark valve springs no. 7, valves no. 6 and rocker arms no. 5. This will ensure that parts will not be inverse at reassembly.

Unscrew rocker arm pivot lock nuts no. 9 and rocker arm pivots no. 8. Remove them.

Remove both rocker arms no. 5.

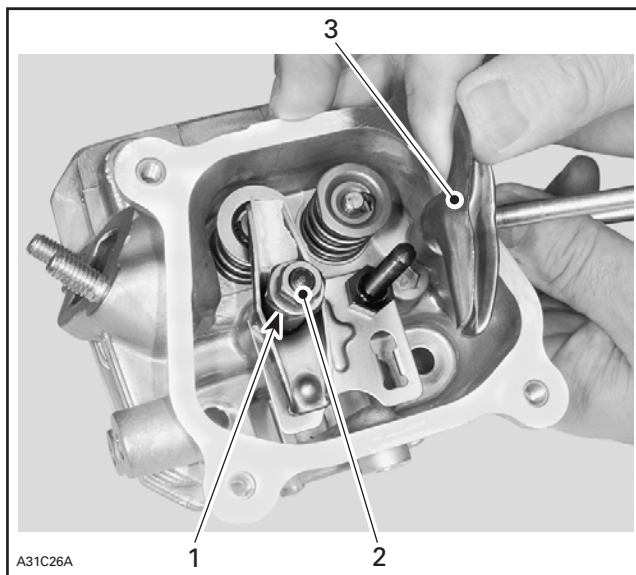

**TYPICAL — MECHANIC REMOVING ROCKER ARM OF INTAKE VALVE**

1. Rocker arm pivot
2. Rocker arm pivot lock nut
3. Rocker arm

Push down and slide the spring retainer no. 13 to the side, so the valve stem slips through the hole, as shown in the next photo.



**TYPICAL — PUSH DOWN AND SLIDE RETAINER TO THE SIDE**

Put apart valve spring retainer and spring.

Repeat procedure for exhaust valve but ensure that valve rotator **no. 14** is removed first. Refer to the following photo.

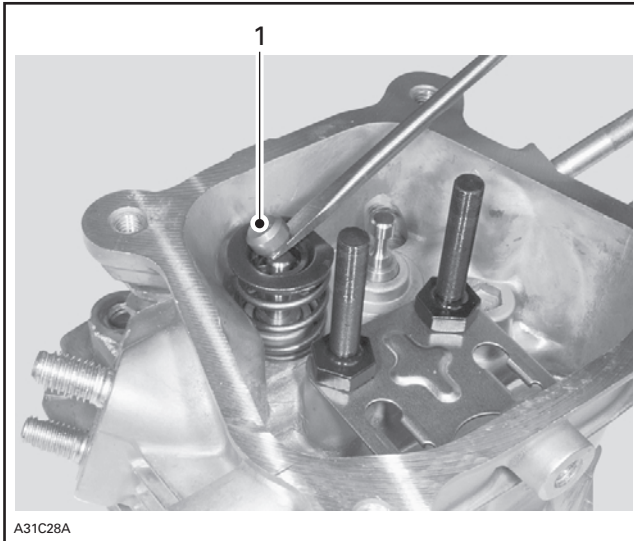

1. On exhaust valve only, remove valve rotator then remove valve spring retainer

Pull out both valves from cylinder head.

## INSPECTION

Refer to COMPRESSION TEST AND ENGINE DIMENSIONS MEASUREMENT 04-05.

## ASSEMBLY

Slide exhaust valve (small diameter) into exhaust valve guide, then slide intake valve (large diameter) into intake guide. See next photo.

Install springs and secure with valve spring retainers.

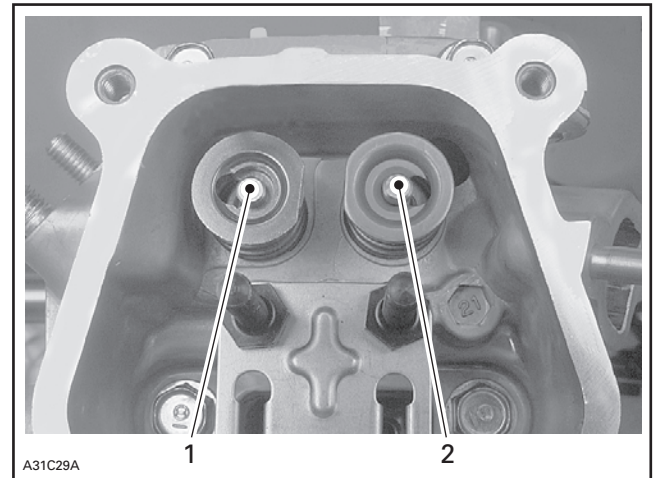

### EXHAUST AND INTAKE VALVES SECURED IN PLACE

1. Exhaust valve (small diameter) location
2. Intake valve (large diameter) location

Install valve rotator on exhaust valve.

**CAUTION:** To avoid engine damage, ensure that exhaust valve rotator is properly installed on exhaust valve, as shown in the next photo.

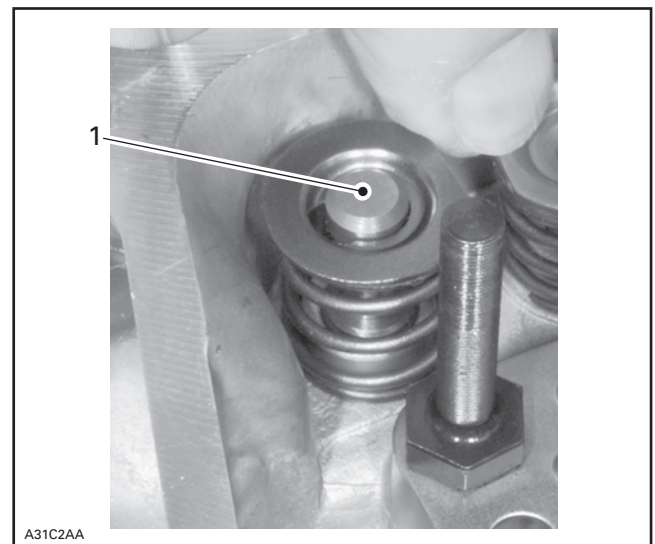

### EXHAUST VALVE SHOWN

1. Exhaust valve rotator in place



---

## Section 04 ENGINE

### Subsection 04 (DISASSEMBLY/ASSEMBLY)

---

#### TOP END INSTALLATION

Install cylinder head gasket no. 15 and check that both locating pins no. 16 are in place, as shown in the next photo.

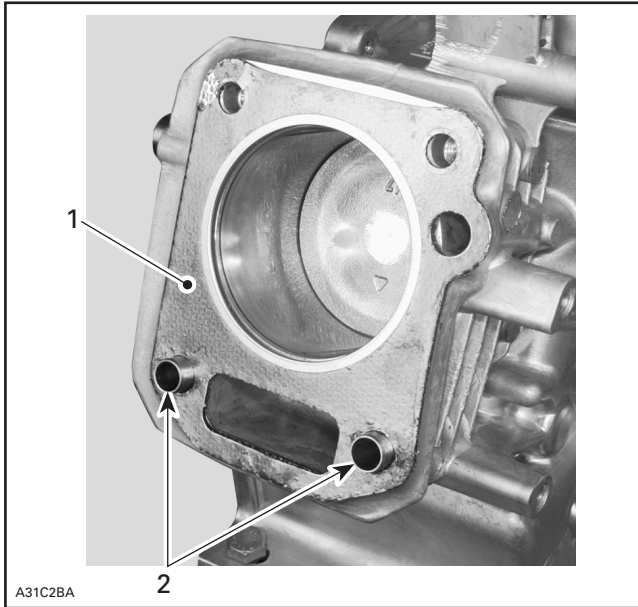

1. Cylinder head gasket
2. Locating pin

Check push rods no. 12 on both ends for wear. Check also push rods for straightness.

Install push rod ends into lifters no. 17.

Reinstall cylinder head.

**CAUTION:** Ensure that push rods are properly inserted into push rod guides and firmly seated in the lifters.

Secure cylinder head with screws.

Reinstall cylinder head cover.

**BOTTOM END**

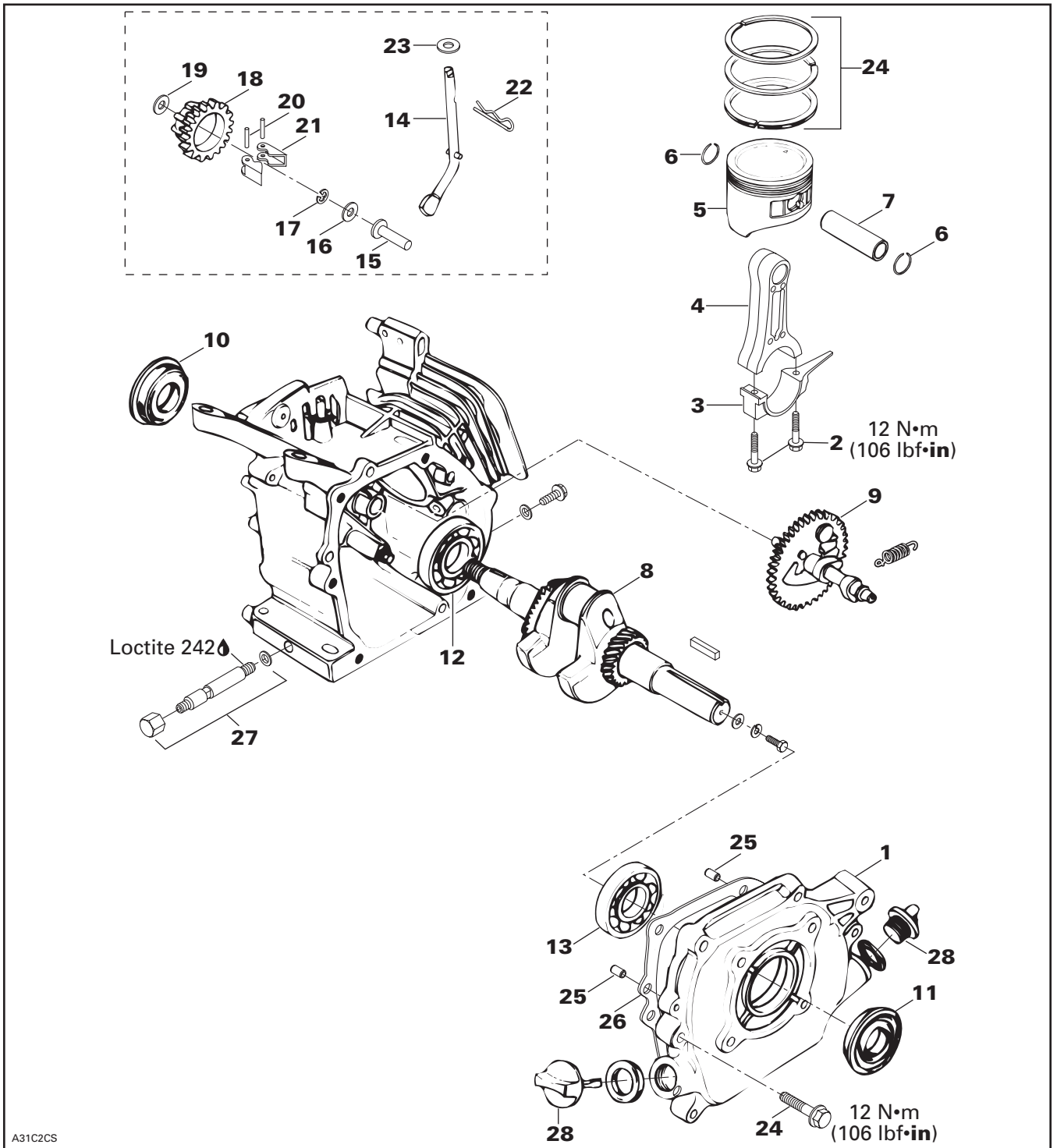

A31C2CS

## Section 04 ENGINE

### Subsection 04 (DISASSEMBLY/ASSEMBLY)

**NOTE:** Engine must be removed from chassis to perform the following procedures.

## CLEANING

Discard all oil seals and gaskets.

Clean all metal components in a non-ferrous metal cleaner.

## DISASSEMBLY

### General

To remove clutch, refer to CLUTCH 05-02.

To remove magneto, refer to TRANSISTORIZED MAGNETO IGNITION 04-06.

### Crankcase

Drain all oil from engine base.

Remove crankcase cover **no. 1** on PTO side.

From inside crankcase, loosen both connecting rod screws **no. 2** then remove connecting rod cap **no. 3**.

Push on connecting rod **no. 4** and pull out piston **no. 5**.

Remove both piston pin circlips **no. 6** and push out piston pin **no. 7**.

Detach piston from connecting rod.

Remove crankshaft **no. 8** and camshaft ass'y **no. 9**.

Mark both valve lifters and remove them. This will ensure that lifters will not be inverse at reassembly.

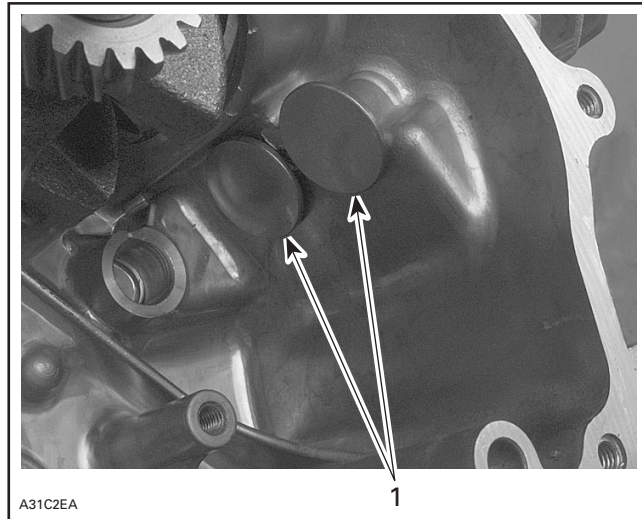

**MARK BOTH VALVE LIFTERS FOR REASSEMBLY**

1. Valve lifters

### Seals and Bearings

To remove seals **nos. 10** and **11**, push from inside crankcase towards the outside.

To remove bearings **nos. 12** and **13**, use a press with all 3 following tools:

- driver (P/N 529 035 521)
- attachment (P/N 529 035 522)
- pilot (P/N 529 035 523)

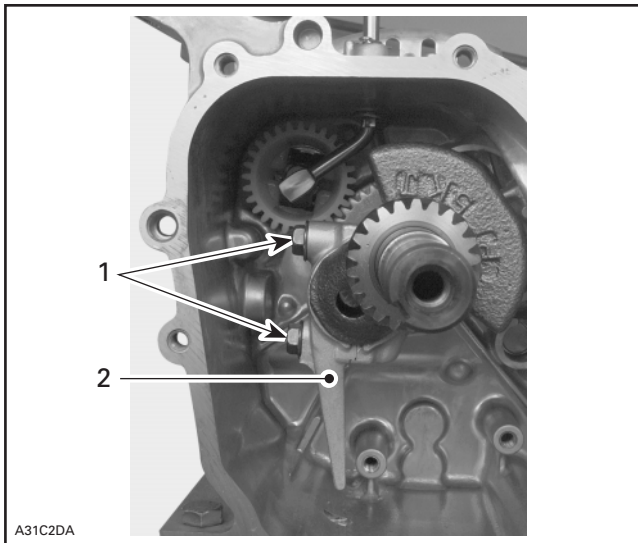

1. Connecting rod screws
2. Connecting rod cap



**Section 04 ENGINE**  
**Subsection 04 (DISASSEMBLY/ASSEMBLY)**

To reinstall bearings, reverse housing and use same tools as for bearings removal, as shown in the next photo.

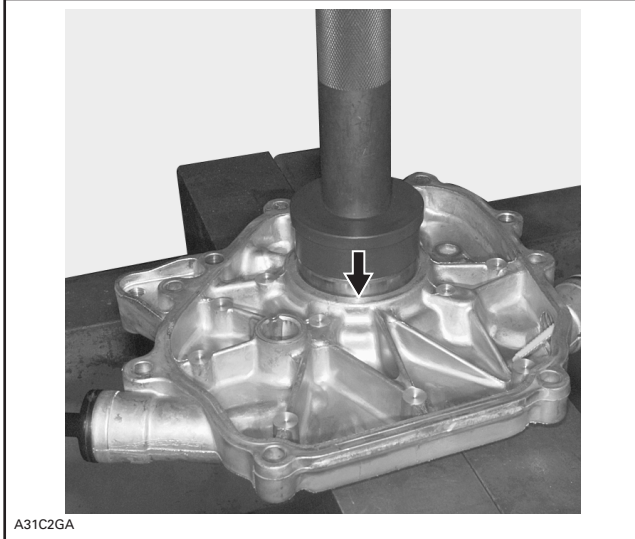

**TO INSTALL BEARING**

### Governor System

Detach governor spring (black), throttle return spring and governor rod from governor arm. See next photo.

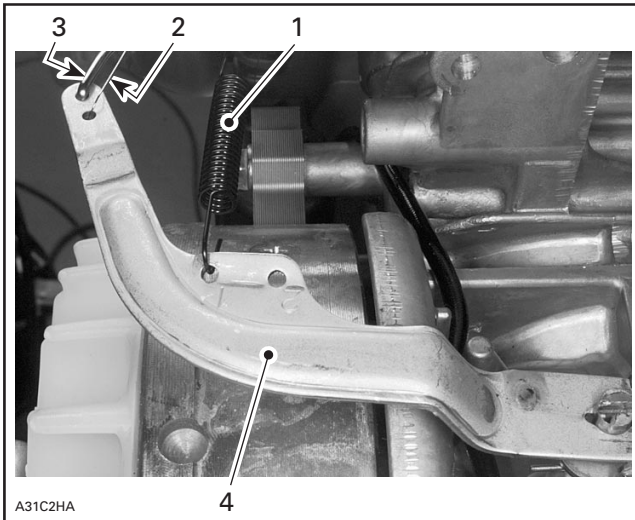

1. Governor spring (black)
2. Throttle return spring
3. Governor rod
4. Governor arm

Loosen governor arm screw then remove governor arm.

From inside crankcase, rotate governor arm shaft no. 14 then pull out governor slider no. 15 and washer no. 16.

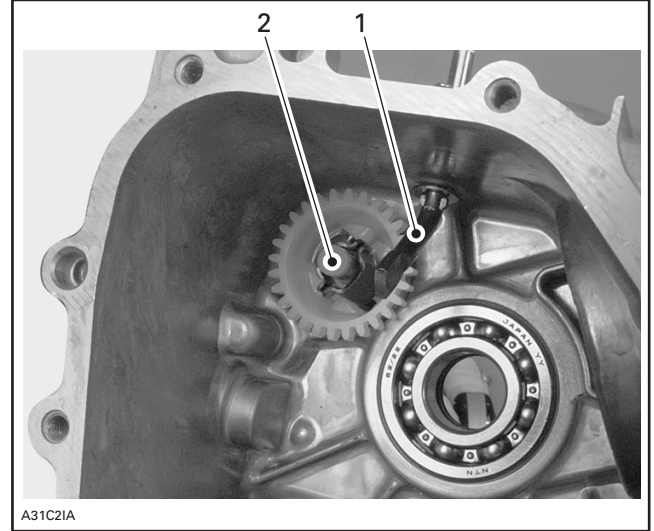

1. Rotate governor arm shaft
2. Remove governor slider with washer (not shown)

Using a small flat screwdriver, remove clip no. 17 from governor weight holder no. 18.

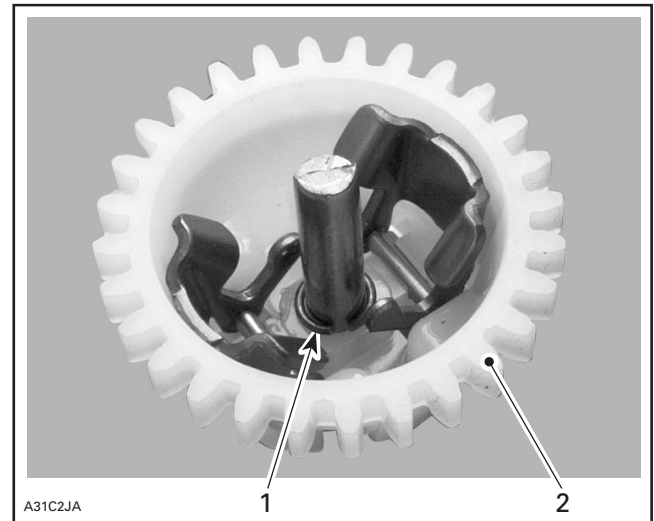

**GOVERNOR ASS'Y HAS BEEN REMOVED TO SHOW CLIP**

1. Clip
2. Governor weight holder

Pull out governor weight holder and washer no. 19. Remove pins no. 20 from governor weights no. 21 then remove governor weights.

## Section 04 ENGINE

### Subsection 04 (DISASSEMBLY/ASSEMBLY)

From outside crankcase, remove lock pin no. 22 from governor arm shaft, as shown in the next photo. Remove governor arm shaft no. 14 with washer no. 23.

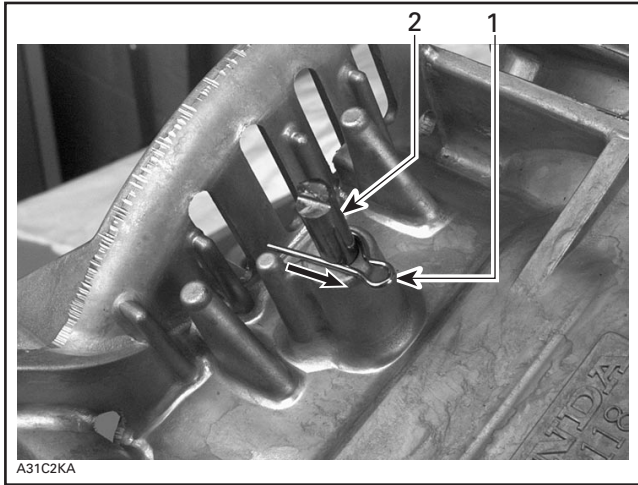

#### REMOVE LOCK PIN

1. Lock pin
2. Governor arm shaft

## INSPECTION

### Piston, Crankshaft and Camshaft

Inspect camshaft decompressor. If there is any problems, replace camshaft assembly with new one.

Refer to COMPRESSION TEST AND ENGINE DIMENSION MEASUREMENT 04-05.

### Governor System

Check for wear or damage on governor weight holder.

Check that governor weights move freely inside governor weight holder.

## ASSEMBLY

### Seals and Bearings

Using a press, install bearings nos. 12 and 13 so that they lean on crankcase flange.

### Governor System

Reinstall governor weights no. 21 with pins no. 20.

Install governor weight holder washer no. 19 then install governor weight holder no. 18 on shaft.

Secure governor weight holder with clip no. 17.

**CAUTION:** Ensure that clip is properly inserted into shaft groove.

Spread governor weights no. 21 then install governor slider washer no. 16 and governor slider no. 15.

Check that governor slider moves smoothly.

Reinstall governor arm shaft no. 14 with washer no. 23 inside crankcase. Secure with lock pin no. 22.

**CAUTION:** The lock pin must be installed on the governor arm shaft with the straight side of the pin against the groove in the shaft.

### Piston and Rings

Align piston mark with connecting rod long end and install piston on connecting rod. See the next illustration.

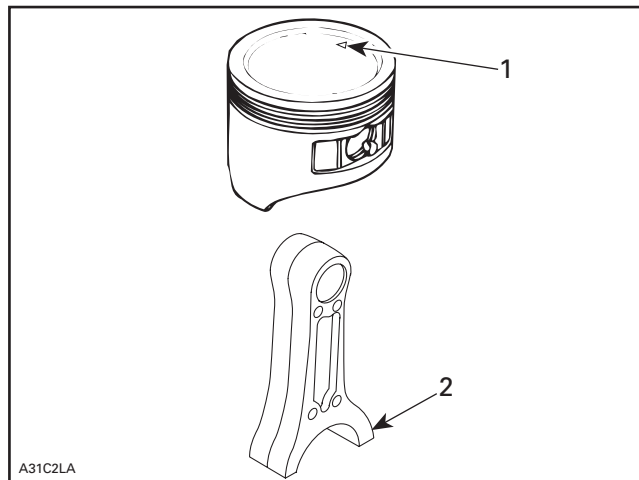

1. Piston mark
2. Connecting rod long end

Insert piston pin no. 7 into piston no. 5 and connecting rod no. 4.

**Section 04 ENGINE**  
**Subsection 04 (DISASSEMBLY/ASSEMBLY)**

Secure piston pin with both piston pin circlips **no. 6**.

**NOTE:** Do not align the end gap of the piston pin circlips with the cutout in the piston bore.

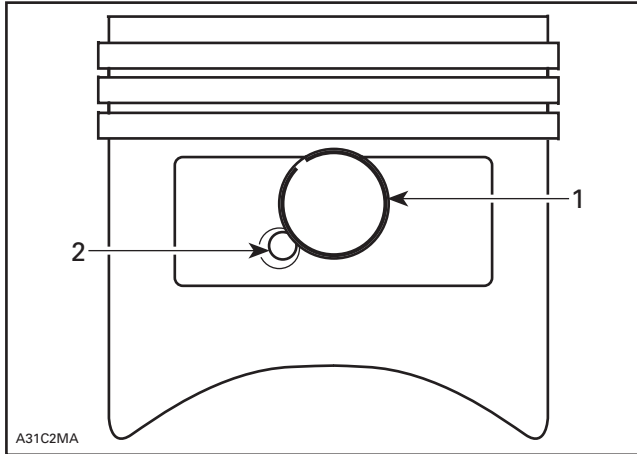

- 1. Piston pin circlip
- 2. Cutout

Install all rings **no. 24** with the markings facing upward.

Ensure that top and second rings are not interchanged.

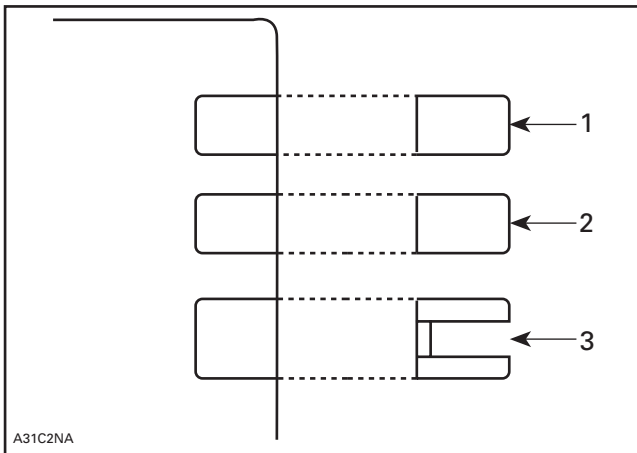

- 1. Top ring (chrome plated)
- 2. Second ring
- 3. Oil ring

Check that rings rotate smoothly after installation.

Space the piston ring end gaps  $120^\circ$  apart and do not align the gaps with the piston pin bore or the thrust side axis.

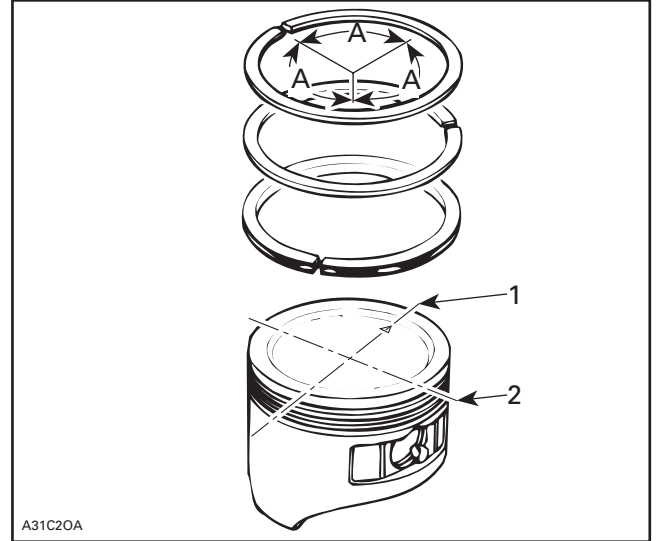

**RING POSITIONING**

- 1. **DO NOT** align ring gap with piston thrust side axis
- 2. **DO NOT** align ring gap with piston pin bore axis
- A.  $120^\circ$

Position piston ass'y with piston mark toward push rod hole, as shown in the following illustration.

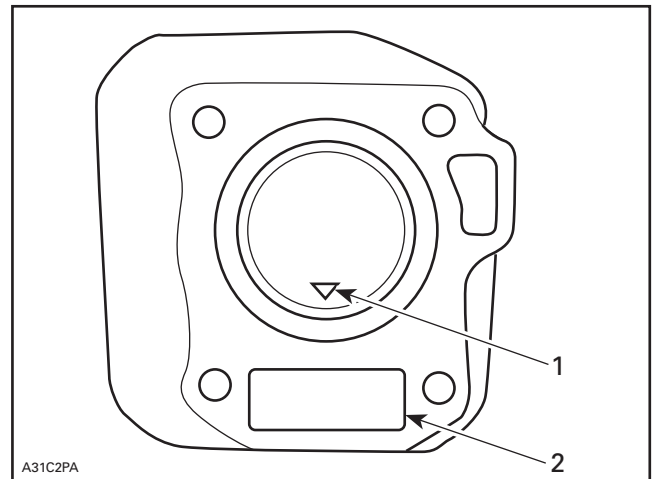

- 1. Piston mark
- 2. Push rod hole

## Section 04 ENGINE

### Subsection 04 (DISASSEMBLY/ASSEMBLY)

Using a ring compressor, slide piston into cylinder with a hammer handle, as shown in the next photo.

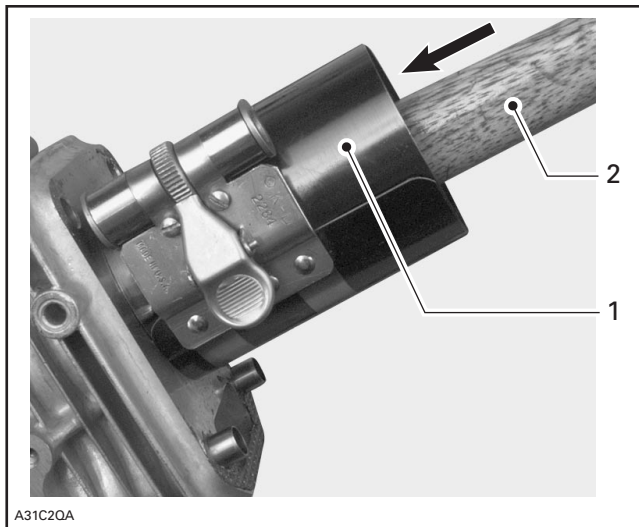

#### SLIDE PISTON INTO CYLINDER

1. Ring compressor
2. Hammer handle

### Crankshaft

Apply oil on crankshaft connecting rod location, connecting rod cap and connecting rod before starting assembly.

Install crankshaft into crankcase.

**NOTE:** To protect seal and ease crankcase cover installation, apply grease on crankcase cover seal.

Slide down piston so that connecting rod properly seats on crankshaft.

Secure connecting rod with connecting rod cap. Torque screws to 12 N•m (106 lbf•in).

**CAUTION:** Ensure that connecting rod cap is properly positioned, as shown in the next photo.

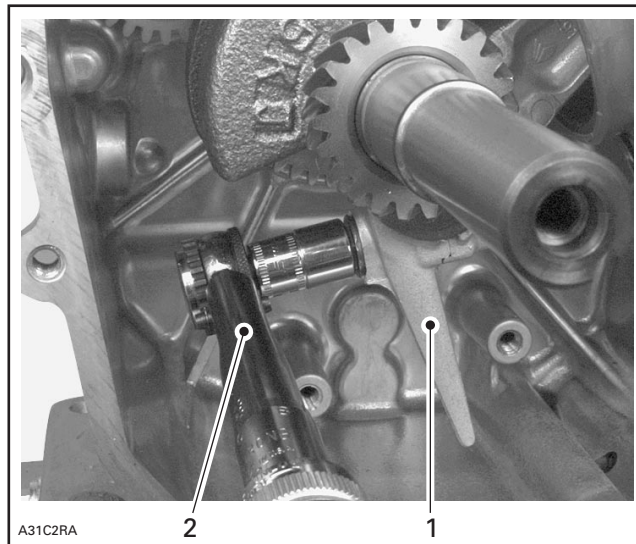

1. Connecting rod cap
2. Torque wrench

### Camshaft

Install exhaust and intake valve lifters inside crankcase.

With the crankshaft in place, align the timing punch mark of the cam gear with the punch mark of the crankshaft drive gear. Refer to the following photo.



ALIGN BOTH MARKS

## Crankcase

Verify that locating sleeves **no. 25** are in place.

Install gasket **no. 26** on crankcase.

Finalize crankcase assembling with crankcase cover **no. 1**. Torque screws in a crisscross sequence to 12 N•m (106 lbf•in).

**NOTE:** To protect seal and ease crankcase cover installation, apply grease on crankcase cover seal.

Verify that oil drain bolt **no. 27** and both oil filler caps **no. 28** are in place.

# COMPRESSION TEST AND ENGINE DIMENSION MEASUREMENT

## COMPRESSION TEST

Set ignition and emergency cut-out switches to the OFF position.

Disconnect spark plug cap, then remove spark plug.

Plug compression testing gauge into spark plug hole.

Hold compression testing gauge in one hand then pull starter handle 3 or 4 times with the other hand, as shown in the next photo.

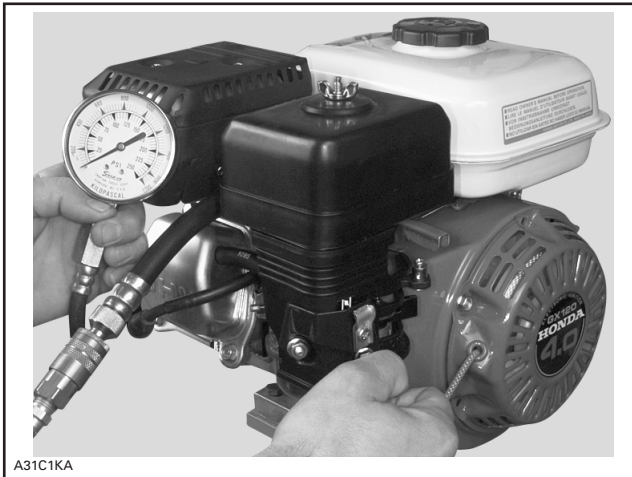

A31C1KA

*PULL STARTER HANDLE 3 OR 4 TIMES*

Engine compression must be as described in the following table. If not, see subsection 04-03 VALVE ADJUSTMENT or subsection 04-04 DISASSEMBLY/ASSEMBLY.

STANDARD	SERVICE LIMIT
110 - 120 PSI	85 PSI



## Section 04 ENGINE

### Subsection 05 (COMPRESSION TEST AND ENGINE DIMENSION MEASUREMENT)

## ENGINE DIMENSION MEASUREMENT

### VALVE SPRING FREE LENGTH

STANDARD	SERVICE LIMIT
30.5 mm (1.20 in)	29.5 mm (1.16 in)

Measure valve springs free length with a caliper, as shown in the next photo.

**NOTE:** When measuring free length, ensure not to apply pressure onto spring.



A31C1LA

#### VALVE SPRING FREE LENGTH

If the springs are shorter than service limit value, replace with new one.

### VALVE SEAT WIDTH

STANDARD	SERVICE LIMIT
0.8 mm (0.03 in)	2.0 mm (0.08 in)

Measure valve seat width using a caliper, as shown in the next photo.



A31C1MA

#### VALVE SEAT WIDTH

If valve seat width is under the standard or over the service limit value, replace cylinder head with new one.

### VALVE STEM (outside diameter)

	STANDARD	SERVICE LIMIT
INTAKE	5.48 mm (0.216 in)	5.318 mm (0.2094 in)
EXHAUST	5.44 mm (0.214 in)	5.275 mm (0.2077 in)

Measure valve stem with a micrometer, as shown in the next photo.



A31C1NA

#### TYPICAL

Inspect valve surface, check for abnormal stem wear and bending. If so, replace valve with new one.

### VALVE GUIDE (inside diameter)

STANDARD	SERVICE LIMIT
5.50 mm (0.217 in)	5.572 mm (0.2194 in)

Clean valve guides to remove carbon deposits before measuring.

Measure valve guide inside diameter using a small hole telescoping gauge and a micrometer.

Replace cylinder head if valve guides are over service limit value.

### GUIDE-TO-STEM CLEARANCE

Subtract each valve stem outside diameter from the corresponding valve guide inside diameter to obtain the stem-to-guide clearance.

	STANDARD	SERVICE LIMIT
INTAKE	0.020 - 0.044 mm (0.0008 - 0.0017 in)	0.10 mm (0.004 in)
EXHAUST	0.006 - 0.087 mm (0.0024 - 0.0034 in)	0.12 mm (0.005 in)

If the stem-to-guide clearance exceeds the service limit value, replace valve or cylinder head as needed.

### CYLINDER HEAD SURFACE

SERVICE LIMIT	0.10 mm (0.004 in)
---------------	--------------------

Clean cylinder head surface.

Check cylinder head flatness with a straight edge and a feeler gauge, as shown in the next photo.

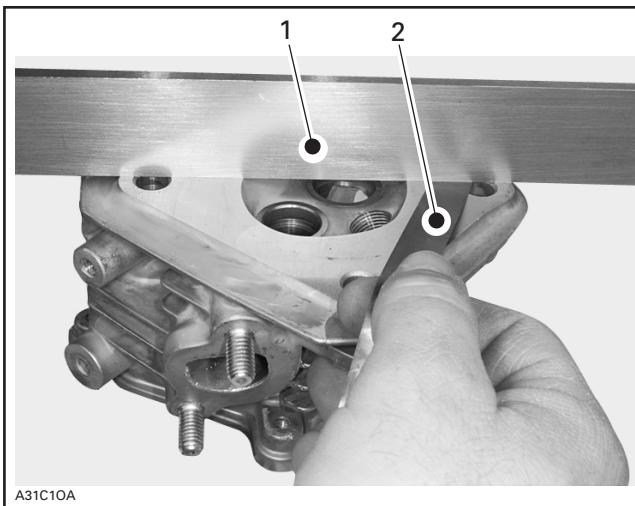

1. Straight edge
2. Feeler gauge

If cylinder head flatness is over service limit value, replace cylinder head.

### Cylinder Head Inspection

Remove carbon deposits from combustion chamber.

Check the spark plug hole and valve areas for cracks.

### CYLINDER INSIDE DIAMETER

STANDARD	SERVICE LIMIT
60.0 mm (2.36 in)	60.165 mm (2.3687 in)

Compare cylinder inside diameter 16 mm (5/8 in) from top of cylinder, halfway and 12.7 mm (1/2 in) from bottom of cylinder.

Measure cylinder inside diameter in both X (perpendicular to crankshaft) and Y (parallel to crankshaft) axis. Take the maximum reading to determine cylinder wear.

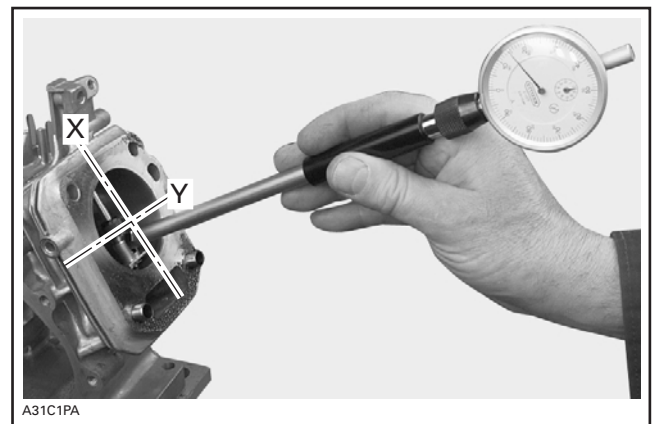

- X: Axis (perpendicular to crankshaft axis)  
Y: Axis (parallel to crankshaft axis)

If the difference exceeds the specified dimension the cylinder should be rebored and honed or should be replaced.

### USED PISTON MEASUREMENT

STANDARD	SERVICE LIMIT
59.985 mm (2.3616 in)	59.845 mm (2.3561 in)

Using a micrometer, measure piston at 10 mm (25/64 in) perpendicularly (90°) to piston pin.



## Section 04 ENGINE

### Subsection 05 (COMPRESSION TEST AND ENGINE DIMENSION MEASUREMENT)

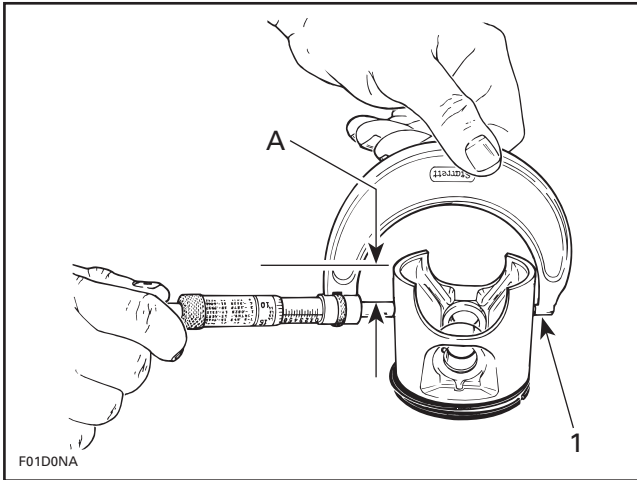

**TYPICAL**

1. Measuring perpendicularly (90°) to piston pin axis  
A. 10 mm (25/64 in)

The measured dimension should be as described in the previous table. If not, install a new piston.

## CYLINDER/PISTON CLEARANCE

STANDARD	SERVICE LIMIT
0.015 - 0.050 mm (0.0006 - 0.0020 in)	0.12 mm (0.005 in)

### Used and New Pistons

**NOTE:** Make sure used piston is not worn. See USED PISTON MEASUREMENT above.

Adjust and lock a micrometer to the piston dimension.

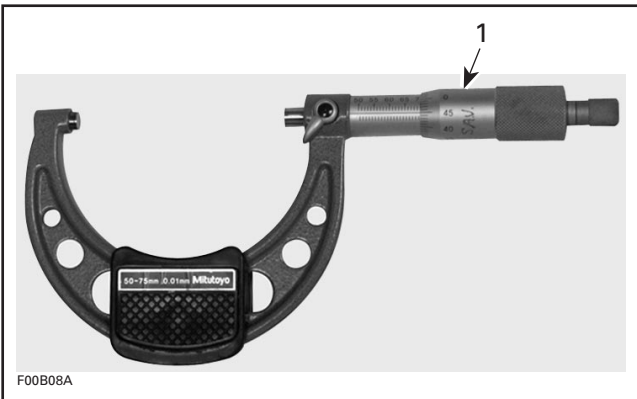

1. Micrometer set to the piston dimension

With the micrometer set to the piston dimension, adjust a cylinder bore gauge to the micrometer dimension and set the indicator to 0 (zero).

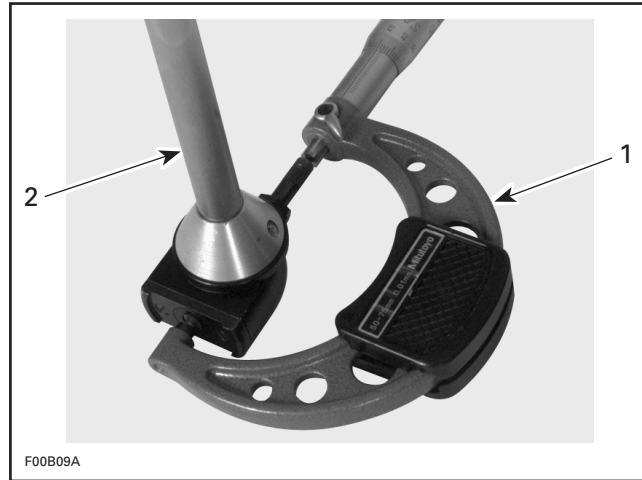

1. Use the micrometer to set the cylinder bore gauge
2. Dial bore gauge

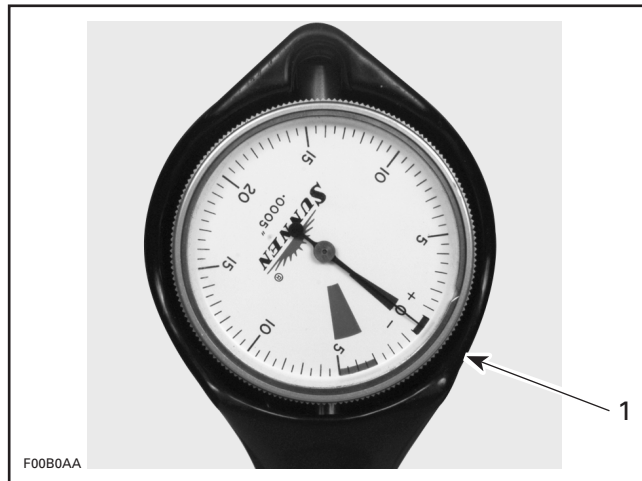

**TYPICAL**

1. Indicator set to 0 (zero)

Position the dial bore gauge at 16 mm (5/8 in) below cylinder top edge, measuring perpendicularly (90°) to piston pin axis. See CYLINDER INSIDE DIAMETER above.

Read the measurement on the cylinder bore gauge. The result is the exact piston/cylinder wall clearance. If clearance exceeds specified tolerance, replace cylinder or rebore. See previous table.

**NOTE:** Make sure the cylinder bore gauge indicator is set exactly at the same position as with the micrometer, otherwise the reading will be false.

### RING/PISTON GROOVE CLEARANCE

STANDARD	SERVICE LIMIT
0.015 - 0.045 mm (0.0006 - 0.0018 in)	0.15 mm (0.006 in)

**NOTE:** These clearances are applicable for 3 rings; top, second and oil ring.

Using a feeler gauge check clearance between ring and groove. Replace piston if clearance exceeds specified tolerance. See above table.



A31C10A  
*RING/PISTON GROOVE CLEARANCE*

### RING END GAP

	STANDARD	SERVICE LIMIT
TOP AND SECOND	0.2 - 0.4 mm (0.008 - 0.016 in)	1.0 mm (0.04 in)
OIL	0.15 - 0.35 mm (0.006 - 0.014 in)	1.0 mm (0.04 in)

Position ring 16 mm (5/8 in) from top of cylinder.

**NOTE:** In order to correctly position the ring in the cylinder, use piston as a pusher.

Using a feeler gauge, check ring end gap. Replace ring, if gap exceeds specified tolerance. See above table.

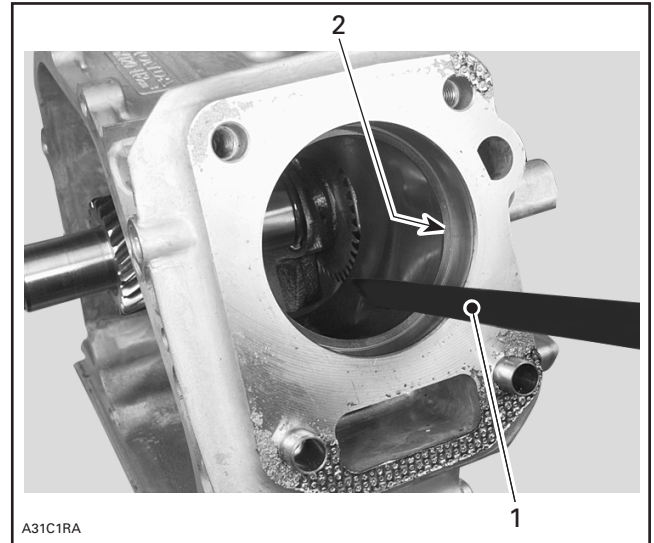

1. Feeler gauge
2. Ring properly positioned in cylinder

### CONNECTING ROD BIG END SIDE CLEARANCE

STANDARD	SERVICE LIMIT
0.1 - 0.7 mm (0.004 - 0.028 in)	1.1 mm (0.043 in)

Using a feeler gauge, measure distance between connecting rod and crankshaft counterweight. If the distance exceeds specified tolerance, replace the crankshaft.



A31C1SA  
*MEASURE SIDE CLEARANCE*

## Section 04 ENGINE

### Subsection 05 (COMPRESSION TEST AND ENGINE DIMENSION MEASUREMENT)

#### PISTON PIN (outside diameter)

STANDARD	SERVICE LIMIT
13.0 mm (0.51 in)	12.954 mm (0.5100 in)

Measure piston pin with a micrometer, as shown in the next photo.



MEASURE PISTON PIN

#### PISTON PIN BORE (inside diameter)

STANDARD	SERVICE LIMIT
13.002 mm (0.5119 in)	13.048 mm (0.5137 in)

Measure piston pin bore with a telescoping gauge and a micrometer, as shown in the next photo.

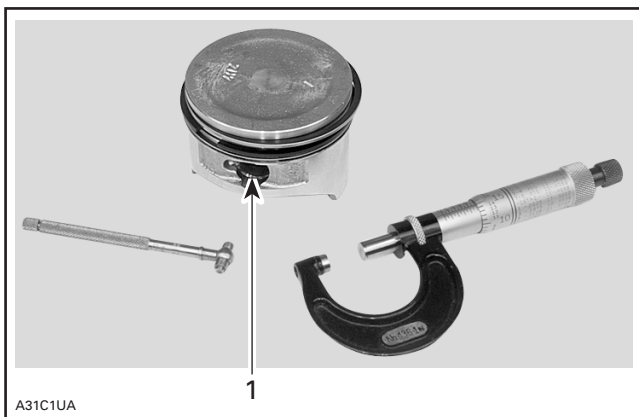

1. Piston pin bore

#### PISTON-TO-PISTON PIN BORE CLEARANCE

STANDARD	SERVICE LIMIT
0.002 - 0.014 mm (0.0001 - 0.0006 in)	0.08 mm (0.003 in)

Compare both previously measured piston pin (outside diameter) and piston pin bore (inside diameter).

If clearance is out of service limit value, replace piston pin or piston as needed.

#### CONNECTING ROD SMALL END (inside diameter)

STANDARD	SERVICE LIMIT
13.005 mm (0.5120 in)	13.07 mm (0.515 in)

Measure connecting rod small end (inside diameter) with a telescoping gauge and a micrometer, as shown in the next photo.



MEASURE CONNECTING ROD SMALL END

#### CONNECTING ROD BIG END (inside diameter)

STANDARD	SERVICE LIMIT
26.02 mm (1.024 in)	26.066 mm (1.0262 in)

Measure connecting rod big end (inside diameter) with a telescoping gauge and a micrometer, as shown in the next photo.



MEASURE CONNECTING ROD BIG END

### CONNECTING ROD BIG END OIL CLEARANCE

STANDARD	SERVICE LIMIT
0.040 - 0.063 mm (0.0016 - 0.0025 in)	0.12 mm (0.005 in)

Clean all oil from crankpin and connecting rod big end surfaces.

Position a piece of plastigauge on the crankpin, as shown on the next photo.

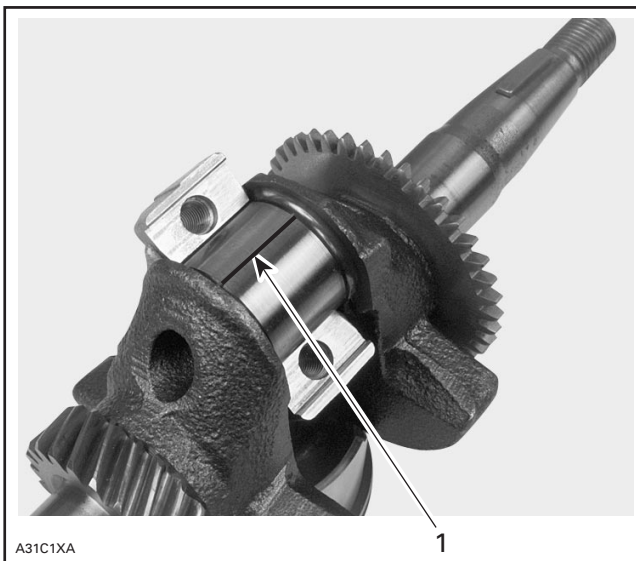

1. Plastigauge properly positioned

Reinstall connecting rod cap and torque screws to 12 N•m (109 lbf•in). See next photo.

**NOTE:** Do not rotate crankshaft while plastigauge is in place.

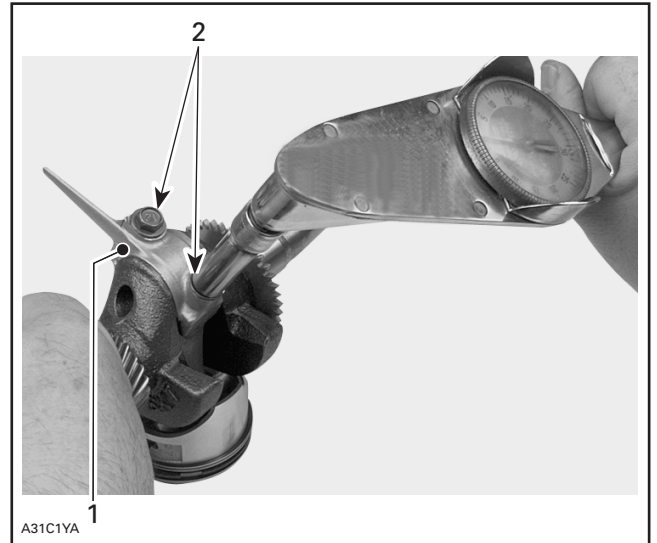

1. Connecting rod cap in place  
2. Torque both screws

Remove connecting rod cap and measure the plastigauge, as shown in the next photo.

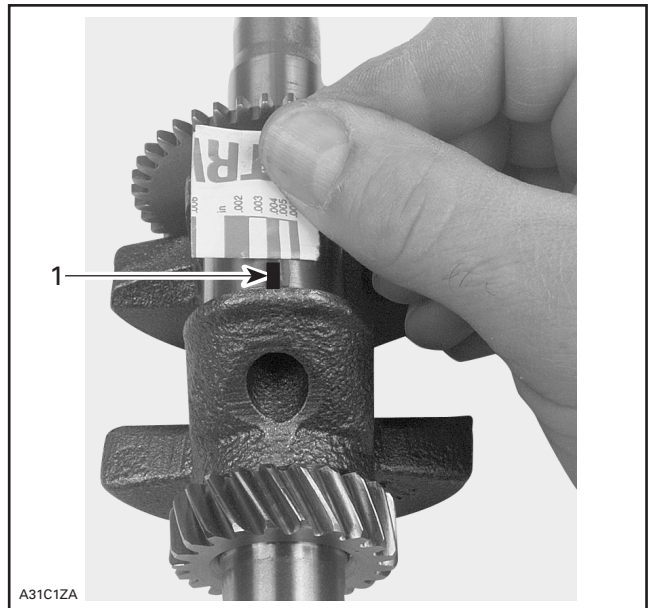

1. Plastigauge

If clearance exceeds the service limit, replace connecting rod and recheck clearance.

**NOTE:** Replacement connecting rods are available with standard and 0.25 mm (0.010 in) under-size bearing surfaces.



## Section 04 ENGINE

### Subsection 05 (COMPRESSION TEST AND ENGINE DIMENSION MEASUREMENT)

#### CRANKPIN (outside diameter)

STANDARD	SERVICE LIMIT
25.98 mm (1.023 in)	25.92 mm (1.020 in)

Measure crankpin outside diameter with a micrometer, as shown in the next photo.



MEASURE CRANKPIN

#### CAMSHAFT CAM HEIGHT

	STANDARD	SERVICE LIMIT
INTAKE	27.7 mm (1.09 in)	27.45 mm (1.081 in)
EXHAUST	27.75 mm (1.093 in)	27.50 mm (1.083 in)

Measure both camshaft cams with a micrometer, as shown in the next photo.

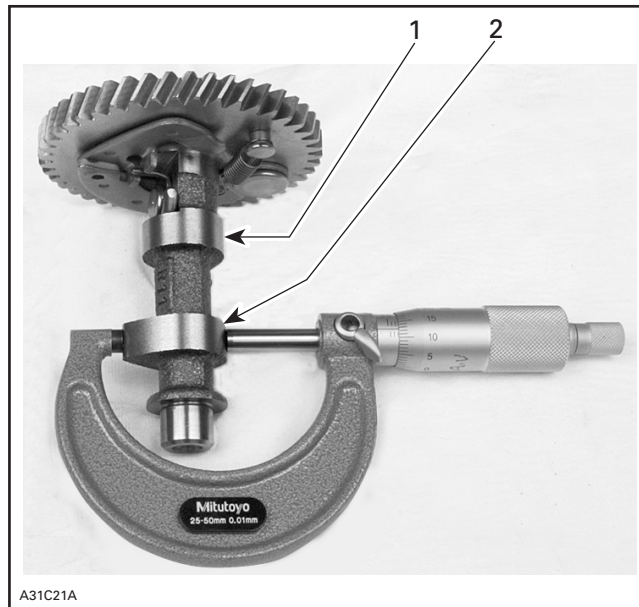

1. Exhaust valve cam
2. Intake valve cam

#### CAMSHAFT (outside diameter)

STANDARD	SERVICE LIMIT
13.984 mm (0.5506 in)	13.916 mm (0.5479 in)

Measure camshaft outside diameter with a micrometer, as shown in the following photo.



MEASURE CAMSHAFT OUTSIDE DIAMETER

### CAMSHAFT HOLDER (inside diameter)

STANDARD	SERVICE LIMIT
14.0 mm (0.55 in)	14.048 mm (0.5531 in)

Measure camshaft holder inside diameter with a telescoping gauge and a micrometer, as shown in the next photo.

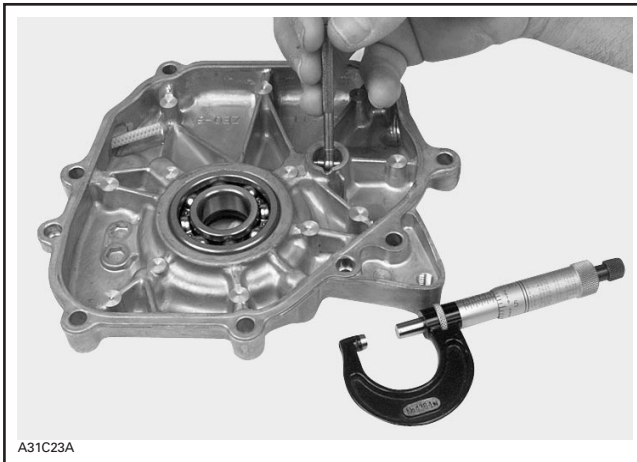

MEASURE CAMSHAFT HOLDER INSIDE DIAMETER

### CHECKING SURFACE FLATNESS

Crankcase cover can be checked for perfectly mating surfaces.

Lay part on a surface plate (marble, mirror or thick glass plate).

Holding down one end of part, try pushing down the other end.

If any play is felt, part must be rectified.

### RECTIFYING SURFACES

Stick a fine sand paper sheet on the surface plate then lightly oil the sand paper.

Rub manifold mating surface on sand paper using 8-figure movements.

Sand until mating surface is perfectly straight.

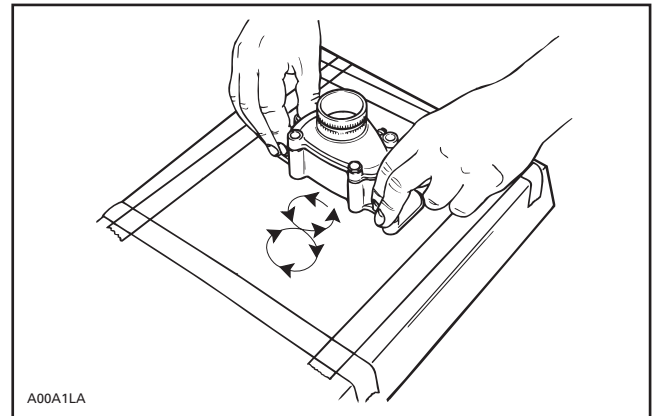

# TRANSISTORIZED MAGNETO IGNITION

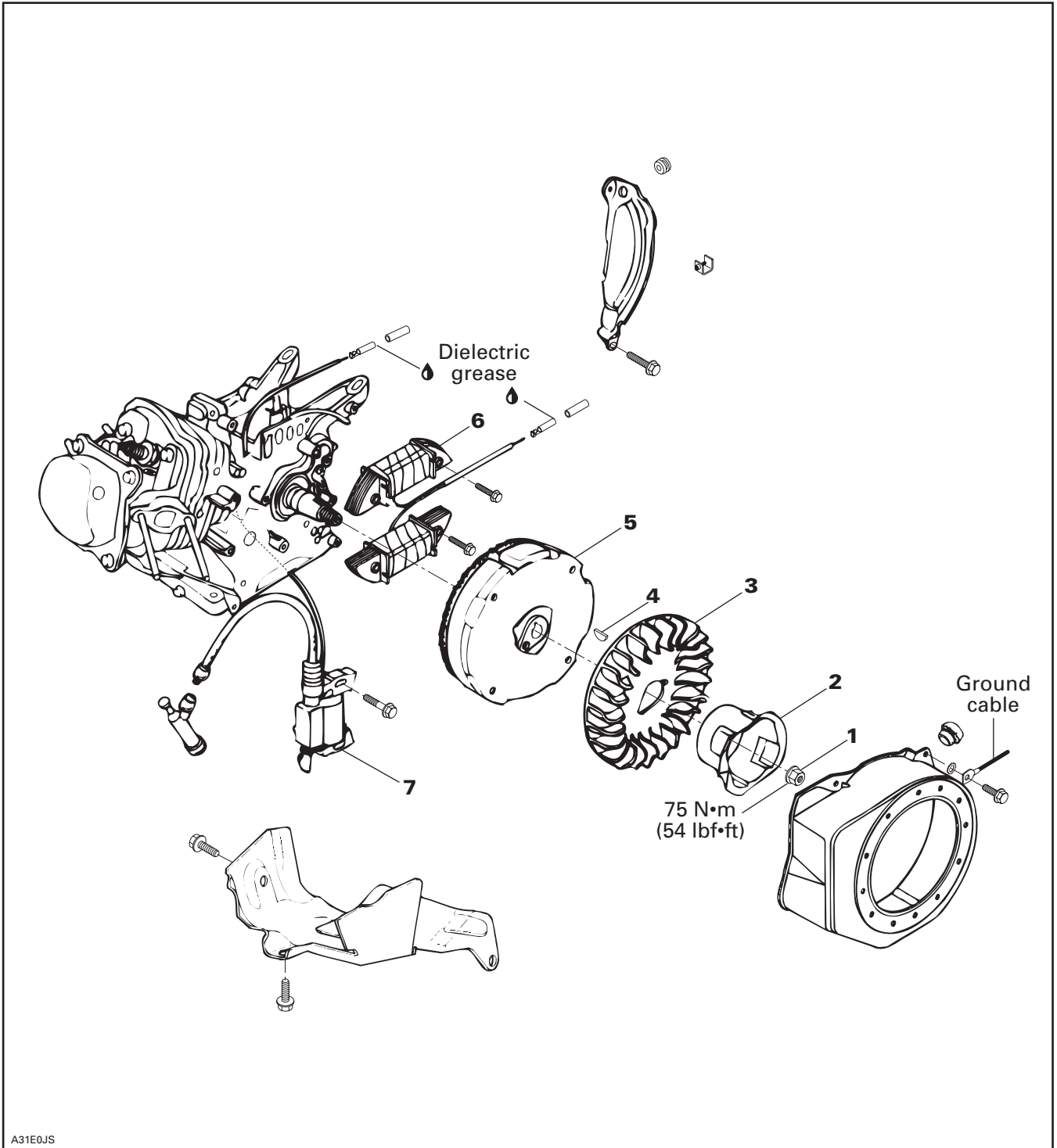

## Section 04 ENGINE

### Subsection 06 (TRANSISTORIZED MAGNETO IGNITION)

**NOTE:** Engine must be removed to perform the following procedures.

## CLEANING

Clean all metal components in a non-ferrous metal cleaner.

**CAUTION:** Clean armature and magneto using only with a clean cloth.

## DISASSEMBLY

To gain access to magneto assembly, remove the following parts:

- chain guard
- drive chain
- clutch
- muffler
- disconnect fuel line
- engine
- rewind starter

Remove ignition coil **no. 7**.

To remove magneto flywheel retaining nut **no. 1**, use clutch holder tool (P/N 529 006 400), as shown in the next photo.

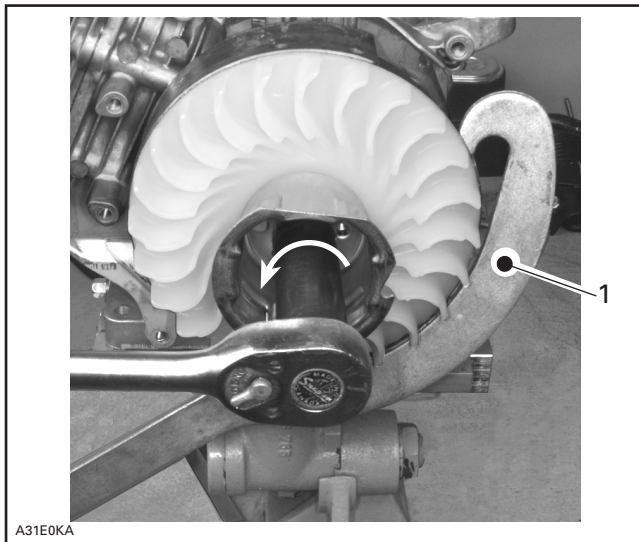

#### LOOSEN FLYWHEEL NUT

1. Hold flywheel using clutch holder tool (P/N 529 006 400)

Remove starter pulley **no. 2** and fan **no. 3**.

Reinstall magneto flywheel nut then using puller, detach flywheel **no. 5**, as shown in the next photo.

**CAUTION:** Never hold flywheel using magnet section. Flywheel may be damaged.

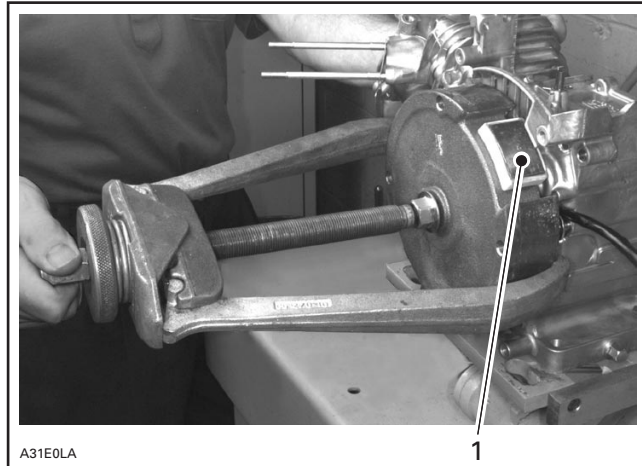

1. Magnet section

**NOTE:** Tighten puller bolt and at same time, tap on bolt head using a hammer to release magneto flywheel from its taper.

## INSPECTION

Test ignition **no. 7** and lamp **no. 6** coils as described in TESTING PROCEDURE 06-03.

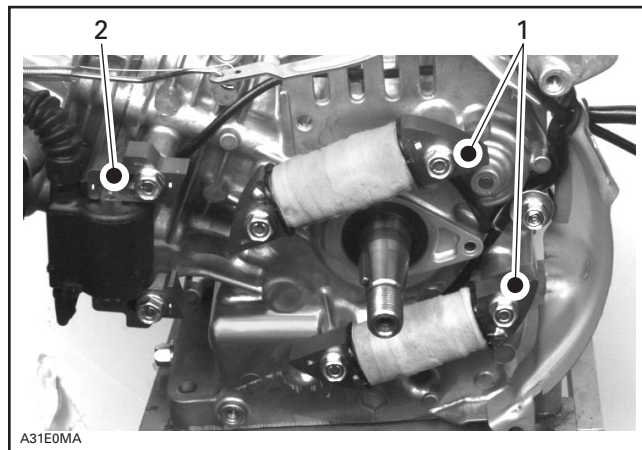

1. Lamp coils
2. Ignition coil



**ASSEMBLY**

Clean crankshaft extension (taper).

Position Woodruff key no. 4 then reinstall flywheel with fan.

Install starter pulley, as shown in the next photo.

**CAUTION:** When installing starter pulley, ensure that locating pin is properly aligned with flywheel alignment hole.

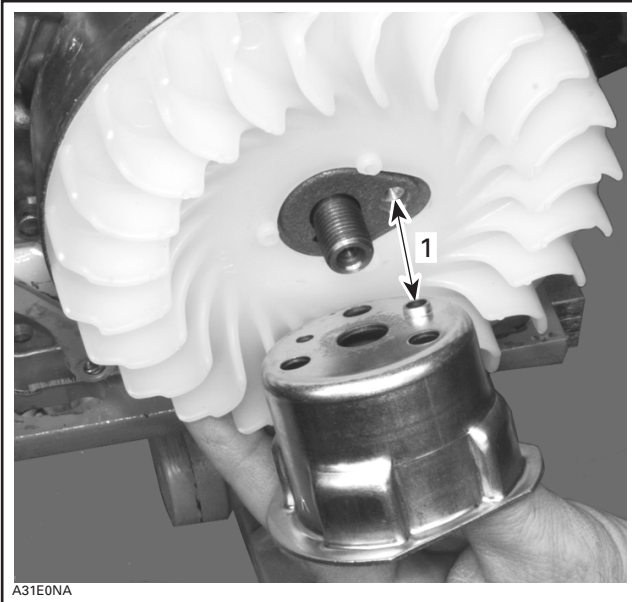

1. Starter pulley locating pin must be aligned with flywheel hole

Torque flywheel nut to 75 N•m (54 lbf•ft).

At reassembly coat all electric connections with silicone dielectric grease (P/N 413 701 700) to prevent corrosion or moisture penetration.

**CAUTION:** Do not use silicone “sealant”, this product will corrode contacts.

**Ignition Coil Air Gap Adjustment**

**NOTE:** To perform ignition coil air gap adjustment, flywheel must be tightened.

Loosen ignition coil screws.

Insert feeler gauge between flywheel and ignition coil. Adjust both gaps at the same time as shown in the next photo and according to the following table.

<b>SPECIFIED CLEARANCE</b>	0.4 ± 0.2 mm (0.016 ± 0.008 in)
----------------------------	------------------------------------

Push the ignition coil firmly toward flywheel and tighten screws.

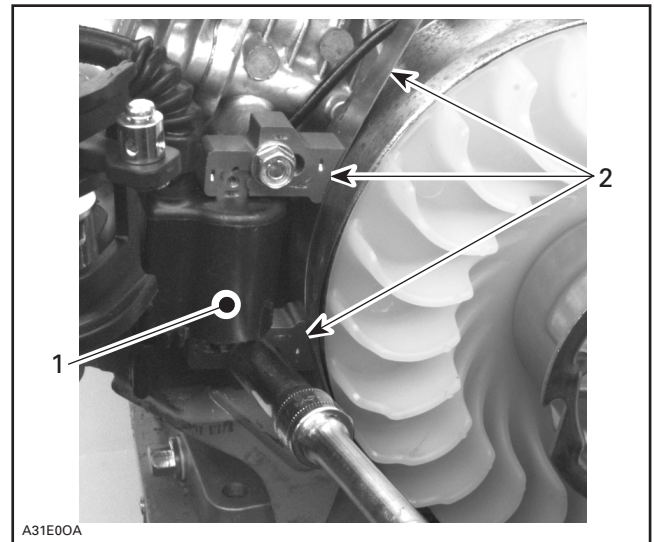

1. Ignition coil  
2. Feeler gauge filling both gaps

**CAUTION:** Do not adjust ignition coil air gap at magnet section on flywheel.

# REWIND STARTER

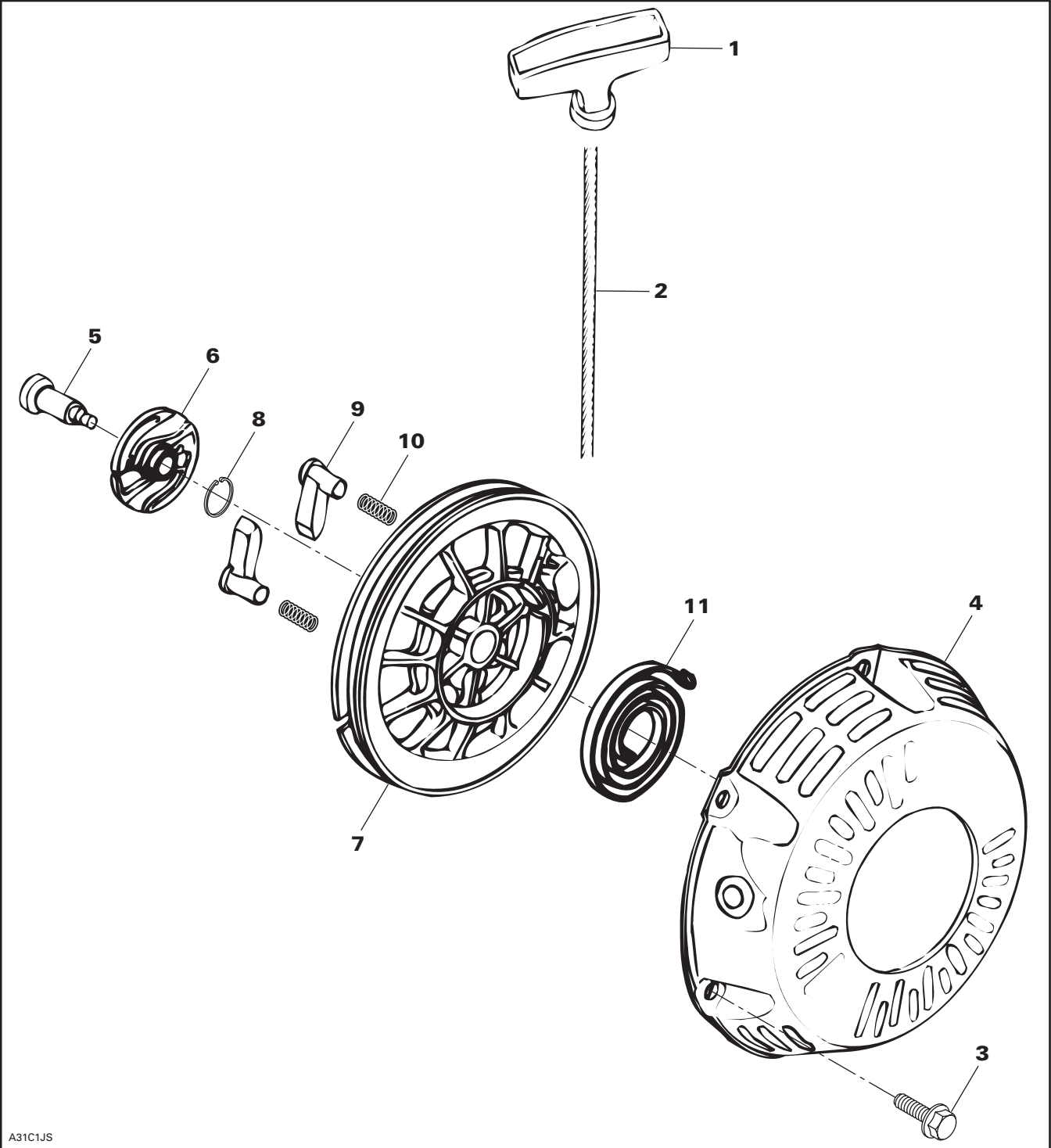

A31C1JS

## Section 04 ENGINE

### Subsection 07 (REWIND STARTER)

## REMOVAL

The following must be removed before rewind starter removal:

- chain guard
- drive chain
- clutch
- muffler
- disconnect fuel hose
- engine

Using a small screwdriver, extract rope knot from starter grip **no. 1**. Cut rope **no. 2** close to knot. Tie a knot near starter.

Mark rewind starter housing **no. 4** position for re-assembly.

Remove screws **no. 3** securing rewind starter housing **no. 4** to engine then remove rewind starter ass'y.

## DISASSEMBLY

To remove rope from rewind starter mechanism:

Place rewind starter ass'y on a bench.

- First remove screw **no. 5**, then ratchet guide **no. 6**.
- Remove friction spring **no. 8** and both ratchets **no. 9** with springs **no. 10**.
- Remove sheave **no. 7** from starter housing, as shown in the next illustration.

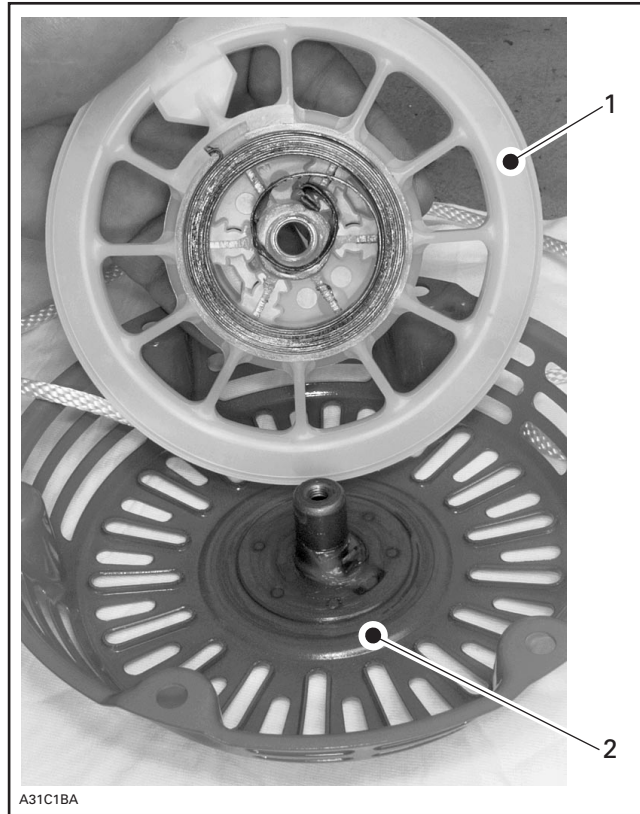

1. Sheave
2. Rewind starter housing

### **WARNING**

Since the spring is tightly wound inside the guide it may fly out when rewind is handled. Always handle with care.

## INSPECTION

Check rope no. 2 for fraying. Replace if so.

## ASSEMBLY

At assembly, position spring no. 11 outer end into spring guide notch then wind the spring counter-clockwise into guide.

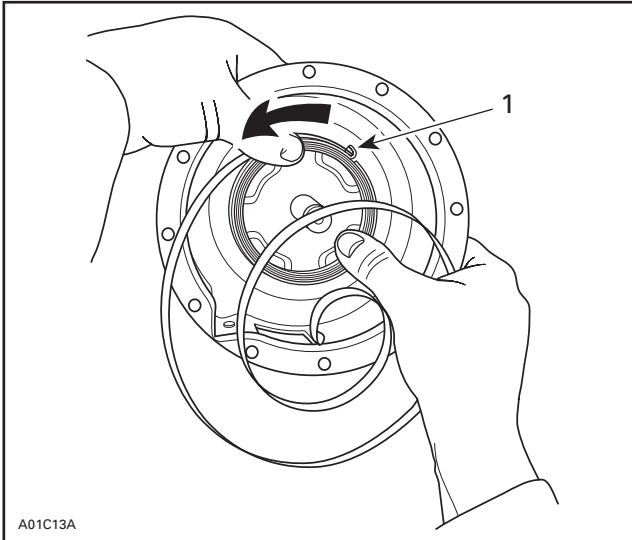

### TYPICAL

1. Outer end into guide notch

**NOTE:** Due to dust accumulation, rewind starter must be periodically cleaned, inspected and relubricated.

**CAUTION:** It is of the utmost importance that the rewind starter spring be lubricated periodically using specific lubricants. Otherwise, rewind starter component life will be shortened and/or rewind starter will not operate properly under very cold temperatures.

Lubricate spring assembly with silicone compound grease (P/N 420 897 061) and position into starter housing as in the next photo.

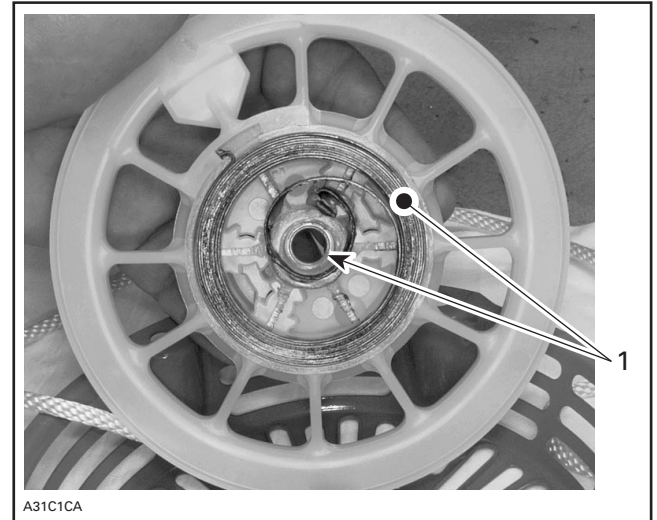

1. Grease inside spring guide and sheave hub

**CAUTION:** The use of standard multi-purpose grease could result in rewind starter malfunction.

To install a new rope:

Insert rope into sheave orifice and lock it with a knot as illustrated.



ROPE KNOT INTO SHEAVE ORIFICE

## Section 04 ENGINE

### Subsection 07 (REWIND STARTER)

To adjust rope tension:

Wind rope on sheave and place sheave into starter housing making sure that the sheave hub notch engages in the rewind spring hook. See the next photo.

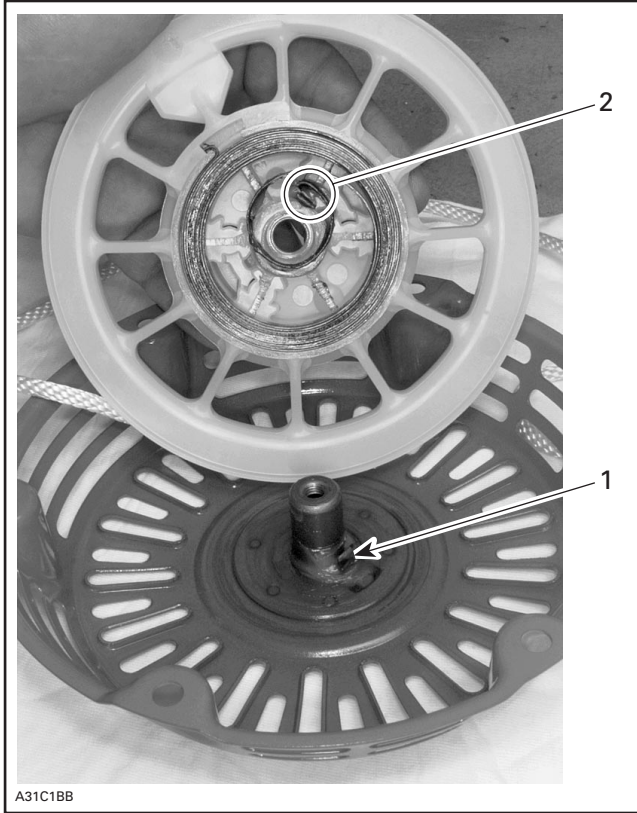

1. Sheave hub notch
2. Rewind spring hook

Rotate the sheave counterclockwise until rope end is accessible through starter housing orifice.

Pull the rope out of the starter housing and temporarily make a knot to hold it.

Position both ratchets (with springs), as shown in the next photo.

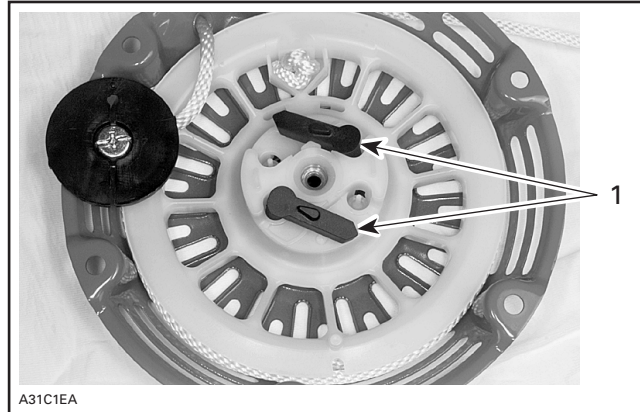

1. Ratchet

Finalize rewind starter assembly with friction spring no. 8, ratchet guide no. 6 and screw no. 5.

Attach rope to sheave notch then turn (2 turns) sheave counterclockwise, as shown in the next photo. One turn preload will give 7 turns of tension when fully extended.

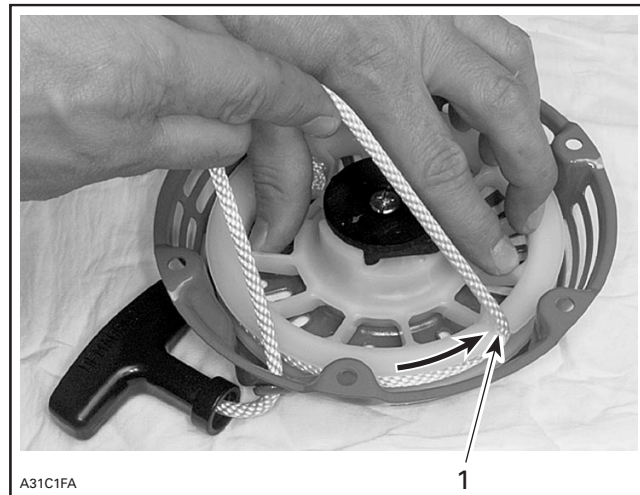

**2 TURNS COUNTERCLOCKWISE**

1. Sheave notch



Check ratchet operation: when turning ratchet guide counterclockwise, ratchets must move in. When turning ratchet guide clockwise, ratchets must move out as shown in the next photo.

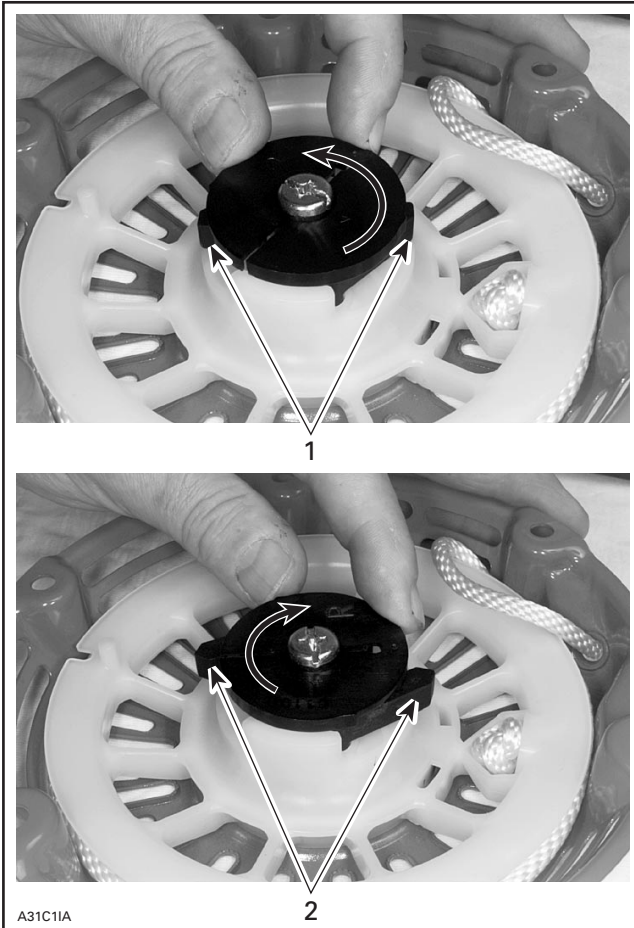

1. Turn counterclockwise (CCW) — ratchets in
2. Turn clockwise (CW) — ratchets out

## INSTALLATION

Reinstall rewind starter ass'y on engine.

Reinstall engine in snowmobile.

Prior to installing starter grip **no. 1** on new rope, it is first necessary to fuse the rope end with a lit match.

Pass rope through snowmobile fitting and starter grip and tie a knot in the rope end. Fuse the knot with a lit match then insert rope end down and pull the starter grip over the knot.

Reconnect fuel hose.

Reinstall clutch, drive chain, then chain guard.

# CARBURETOR

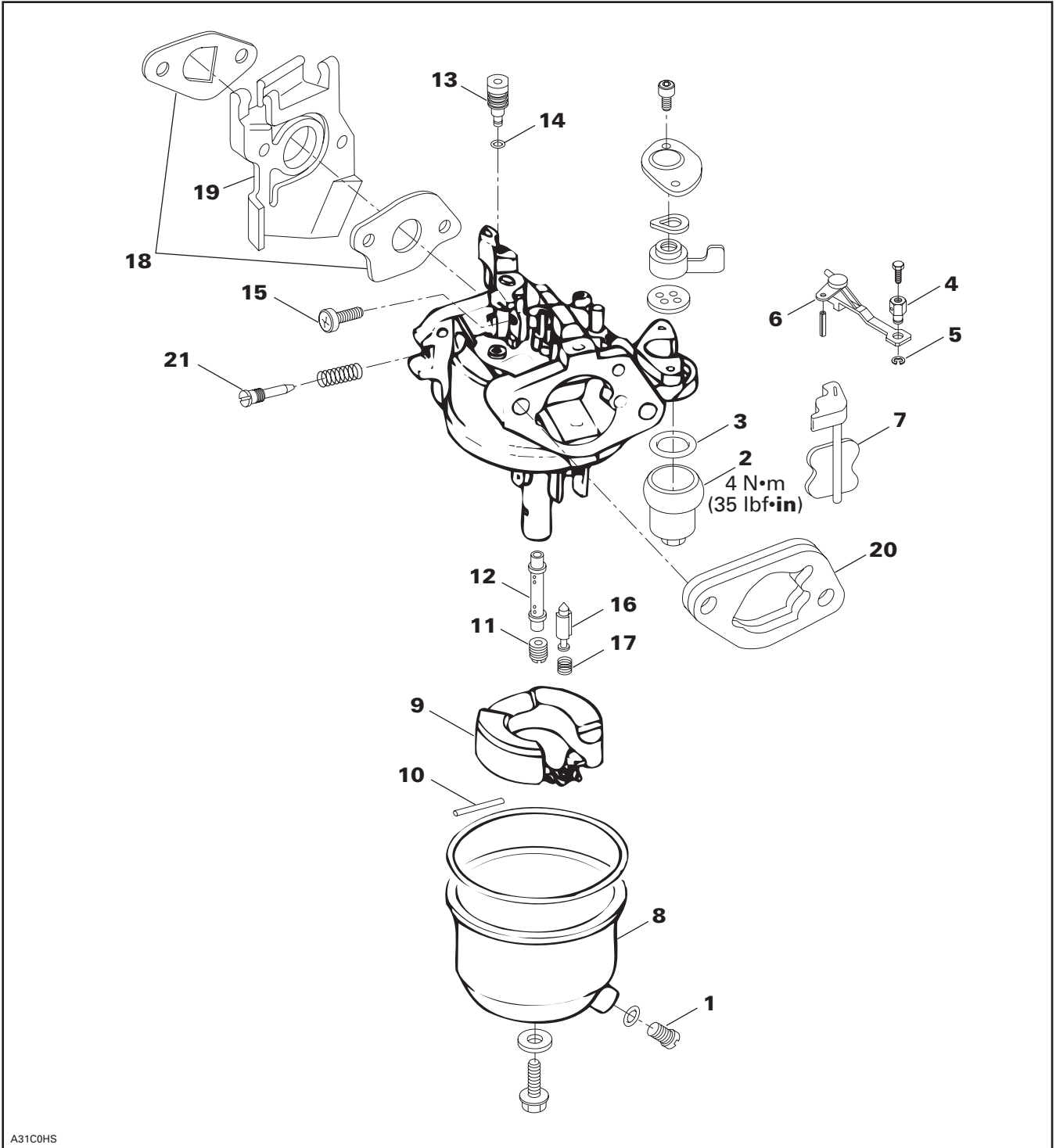

A31C0HS

## Section 04 ENGINE

### Subsection 08 (CARBURETOR)

## REMOVAL

Remove engine protective plate.

Obstruct fuel line with a hose pincher (P/N 295 000 076), as shown in the next photo.

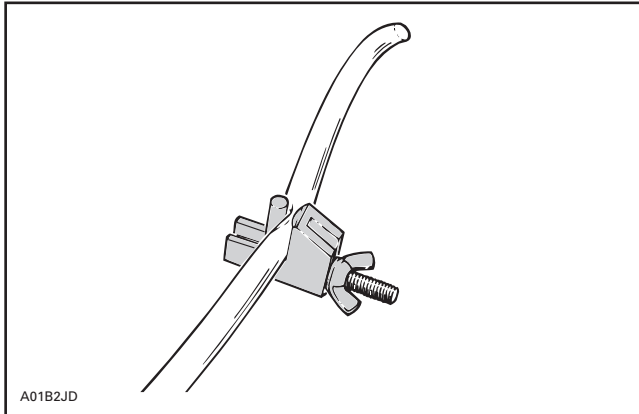

Drain fuel from carburetor by loosening screw **no. 1**, as shown in the next photo.

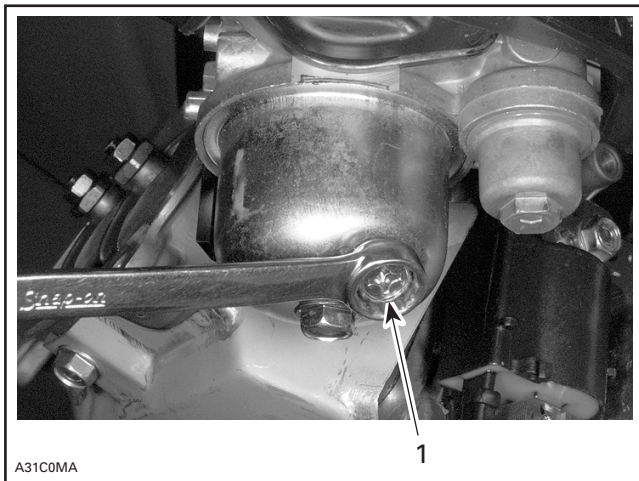

#### TO DRAIN CARBURETOR

1. Loosen this screw

Loosen fuel strainer cup **no. 2** and remove from carburetor. Keep O-ring **no. 3**, as shown in the next photo.

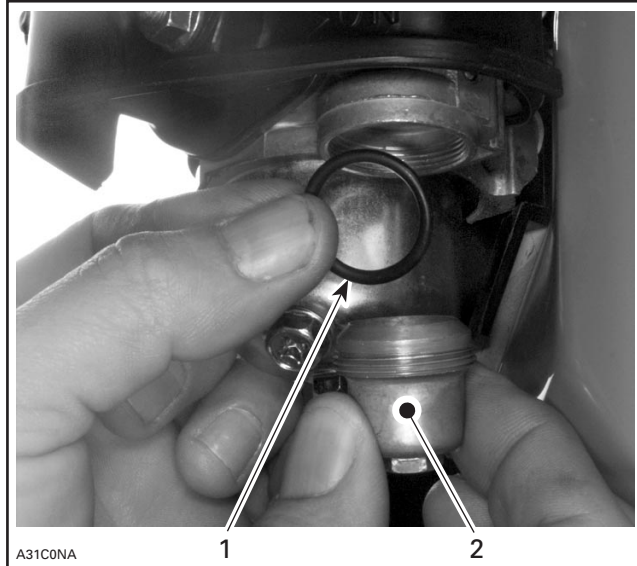

#### REMOVE FUEL STRAINER CUP

1. O-ring
2. Fuel strainer cup

Disconnect fuel inlet line from carburetor and drain fuel from tank.

### WARNING

When draining a fuel tank or whenever a fuel line is disconnected, obstruct line with a hose pincher (P/N 295 000 076) or equivalent device. Fuel is flammable and explosive under certain conditions. Ensure work area is well ventilated. Do not smoke or allow open flames or sparks in the vicinity.

Remove fuel tank.

Remove carburetor cap.

Detach choke cable from choke cable attachment **no. 4**, located on carburetor choke lever **no. 6**.



**Section 04 ENGINE**  
**Subsection 08 (CARBURETOR)**

Remove circlip **no. 5** then remove choke cable attachment from carburetor choke lever, as shown in the next photo.

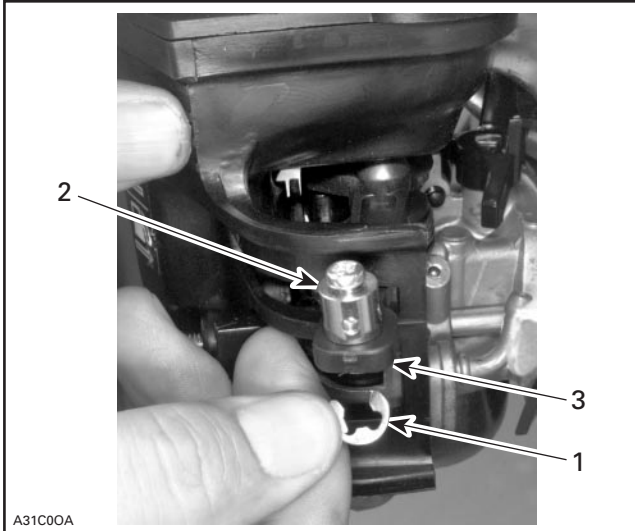

1. Circlip
2. Choke cable attachment
3. Carburetor choke lever

Move carburetor choke lever to the left, as shown in the next photo.

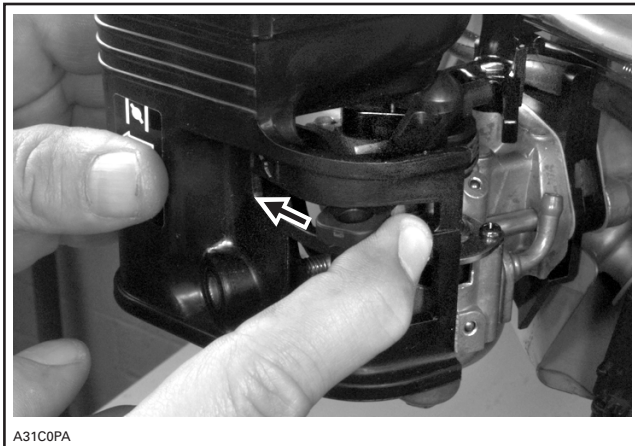

**MOVE CARBURETOR CHOKE LEVER**

Unscrew carburetor protector screws then remove carburetor nuts.

Remove carburetor protector, as shown in the next photo.

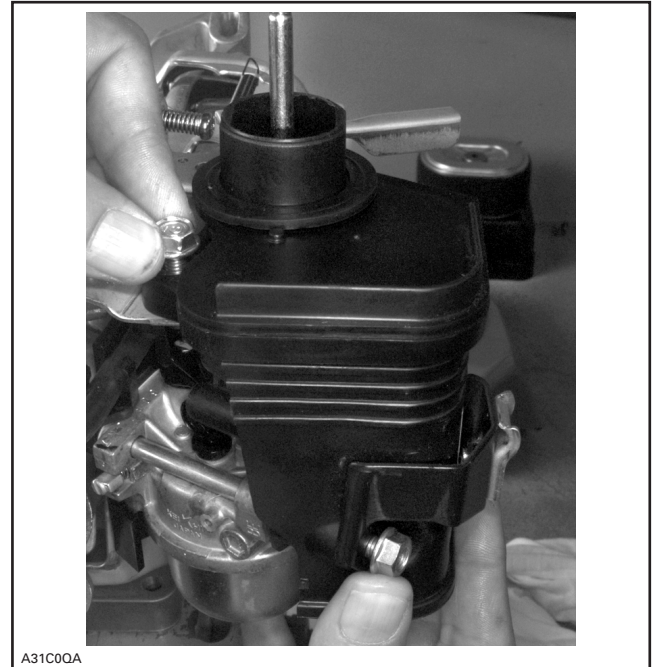

**REMOVE CARBURETOR PROTECTOR**

Lift up choke lever **no. 6** and detach from choke **no. 7**, as shown in the next photo.

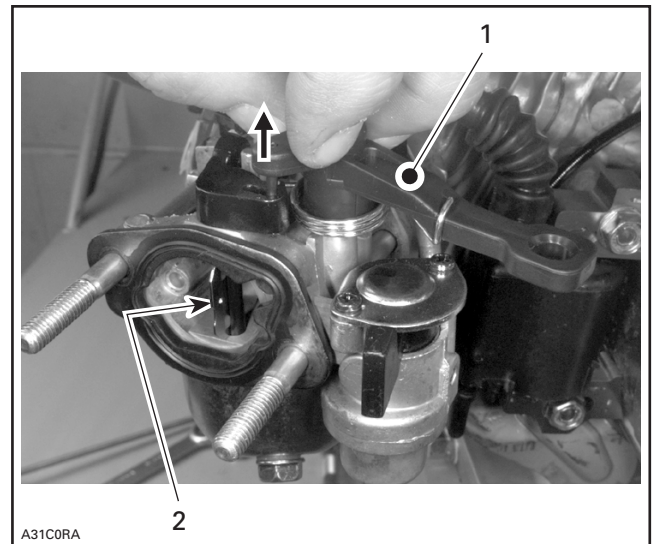

**LIFT UP CHOKE LEVER**

1. Choke lever
2. Choke

## Section 04 ENGINE

### Subsection 08 (CARBURETOR)

Slide out carburetor and activate carburetor throttle lever so that groove aligns with governor rod, as shown in the next photo.

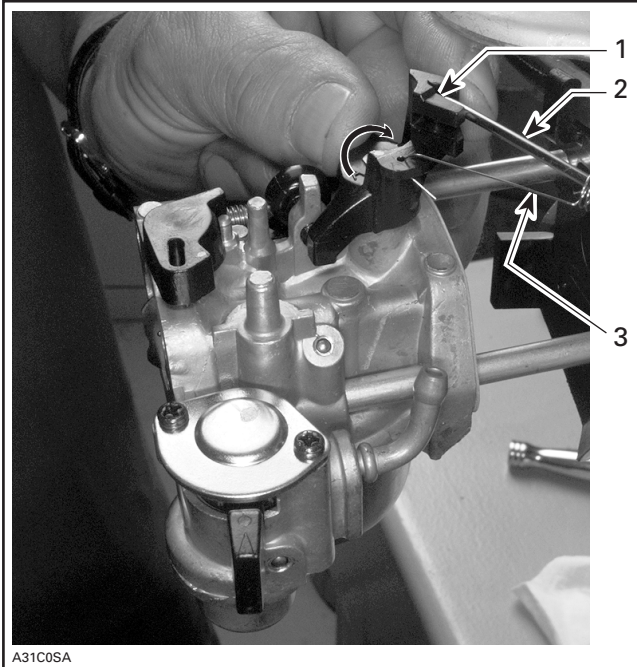

#### SLIDE OUT CARBURETOR AND ALIGN GROOVE

1. Carburetor throttle lever groove aligned with governor rod
2. Governor rod
3. Throttle return spring

Detach governor rod with throttle return spring.

Detach governor spring.

Remove carburetor.

**NOTE:** Carburetor can be removed without removing engine from vehicle, in that case remove left side stud.

## CLEANING AND INSPECTION

The entire carburetor should be cleaned with a general solvent and dried with compressed air before disassembly.

**CAUTION:** Heavy duty carburetor cleaner may be harmful to the float material and to the rubber parts, O-rings, etc. Therefore, it is recommended to remove those parts prior to cleaning.

Carburetor body and jets should be cleaned in a carburetor cleaner following manufacturer's instructions.

### **⚠ WARNING**

Solvent with a low flash point such as gasoline, naphtha, benzol, etc., should not be used as they are flammable and explosive.

Check for fuel soaked into float **no. 8**. Replace as necessary.

Check float **no. 9** and float pin **no. 10** for cracks or other damages affecting free movement. Replace as necessary.

## DISASSEMBLY AND ASSEMBLY

### 11,12, Main Jet and Nozzle

Place carburetor on a clean surface, then unscrew main jet **no. 11** using a flat screwdriver, as shown in the next photo.

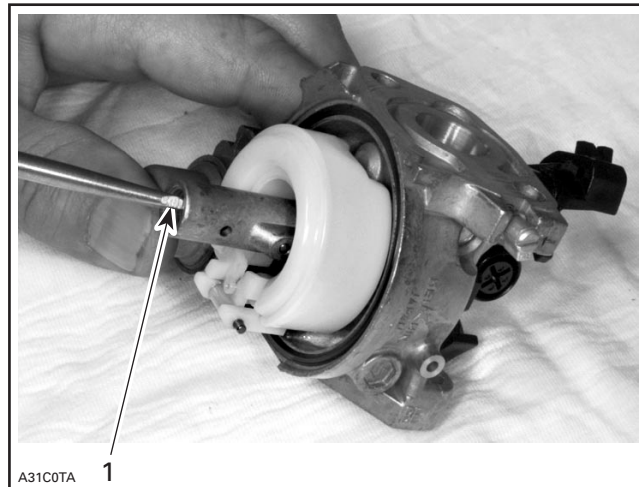

1. Unscrew main jet using a flat screwdriver

To remove nozzle no. 12 use a flat screwdriver and push from inside carburetor, as shown in the following photo.

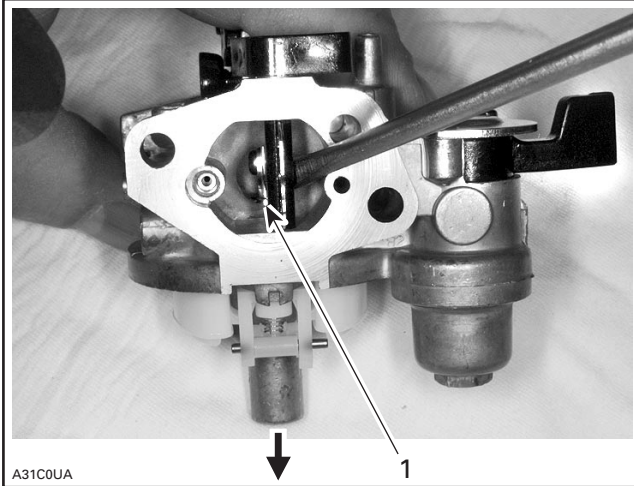

1. Push on nozzle to remove it

Clean main jet and nozzle thoroughly with compressed air.

Reinstall nozzle and main jet as shown in the next photo.

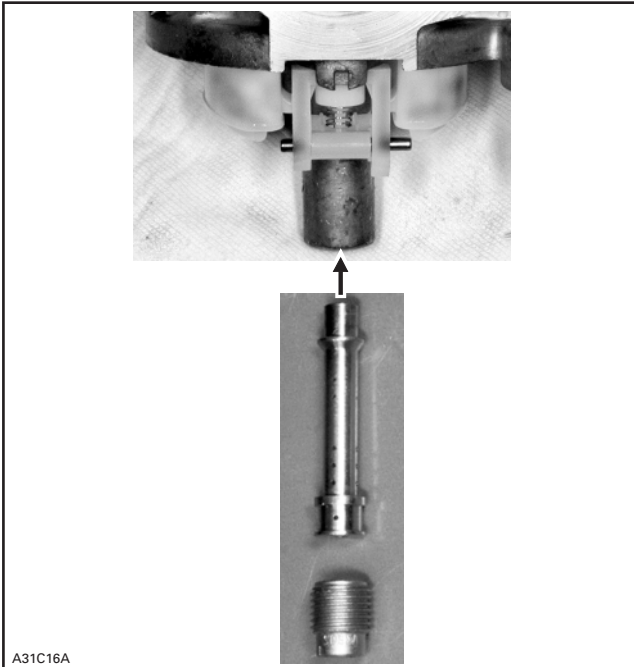

PROPER POSITION TO INSTALL NOZZLE AND MAIN JET

### 13,14, Pilot Jet

Remove stop screw no. 15.

Using a flat screwdriver remove pilot jet no. 13, as shown in the next photo.

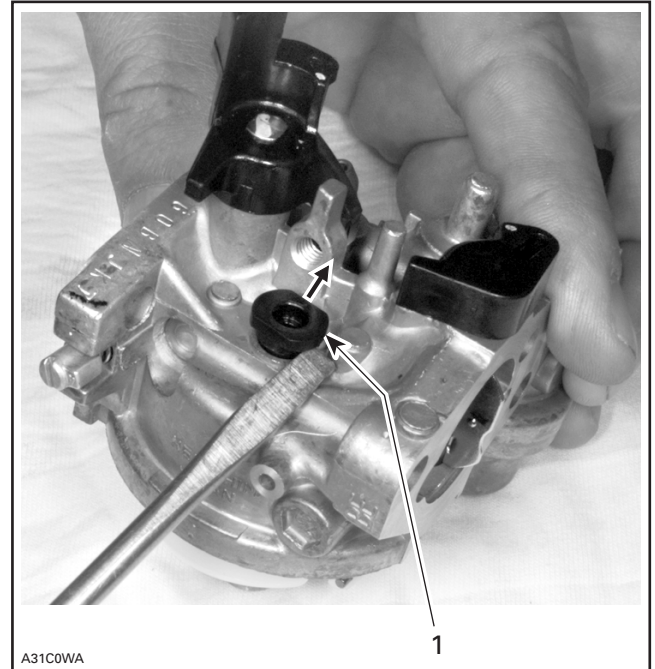

TO REMOVE, LIFT PILOT JET

1. Pilot jet

Clean pilot jet using compressed air.

Ensure that O-ring no. 14 is not damaged. If so, replace with new one. See next photo.

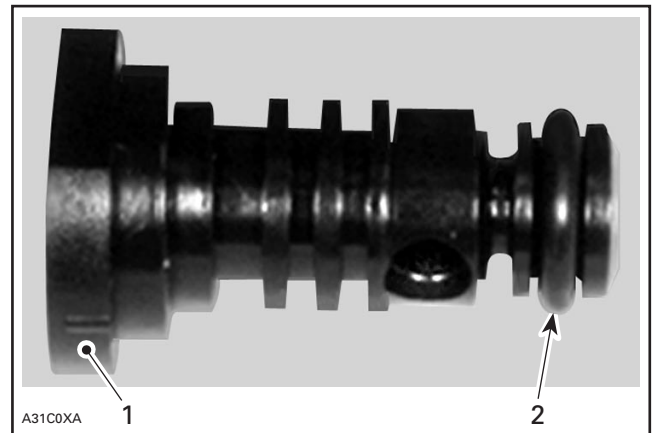

1. Pilot jet  
2. O-ring



## Section 04 ENGINE

### Subsection 08 (CARBURETOR)

#### 16,17, Float Valve

Remove float pin no. 10 then remove float no. 9 from carburetor.

Check for worn valve seat on float. Replace if so.

Check for weak float valve spring no. 17 or worn float valve, as shown in the next photo.

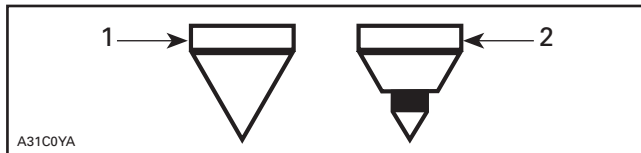

1. Float valve tip OK
2. Replace float valve

#### CARBURETOR FLOAT LEVEL

Correct fuel level in float chamber is vital toward maximum engine efficiency. To check for correct float level proceed as follows:

- Remove float bowl no. 8 and gasket from carburetor.
- With carburetor leaned on a clean surface, measure float level height A using float level gauge (P/N 529 035 520), as shown in the next photo.
- Keep float level gauge perfectly vertical and in line with main jet hole.
- Ensure that both float level gauge tips are properly positioned on carburetor body and that "L" arm is leaning on float without compressing valve spring.

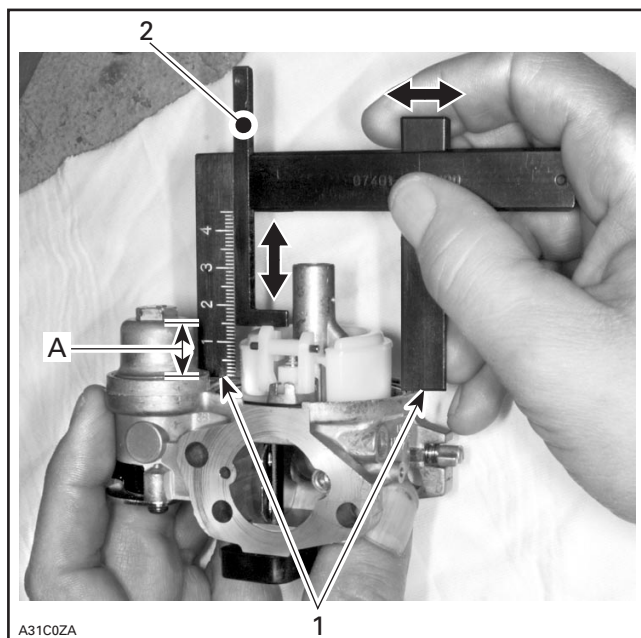

1. Float level gauge tips properly leaned on carburetor body
2. Lean "L" arm to carburetor to measure float level height
- A. Float level height

STANDARD FLOAT HEIGHT	13.7 mm (0.54 in)
-----------------------	-------------------

If float height is not according to specifications on above table, replace float and/or float valve.

Recheck float level height.

#### INSTALLATION

To install carburetor on engine, inverse removal procedure.

However, pay attention to the following:

- Inspect throttle cable and housing prior to installation.
- Ensure that both packings no. 18 and insulator no. 19 are properly positioned between cylinder head and carburetor, as shown in the next photo.

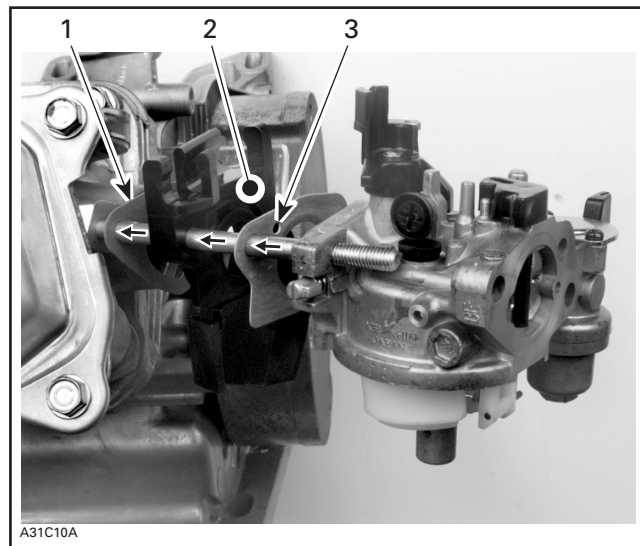

1. Packing
2. Insulator
3. Note packing hole position

- Ensure that spacer no. 20 is properly positioned between carburetor and air cleaner elbow ass'y, as shown in the following photo.

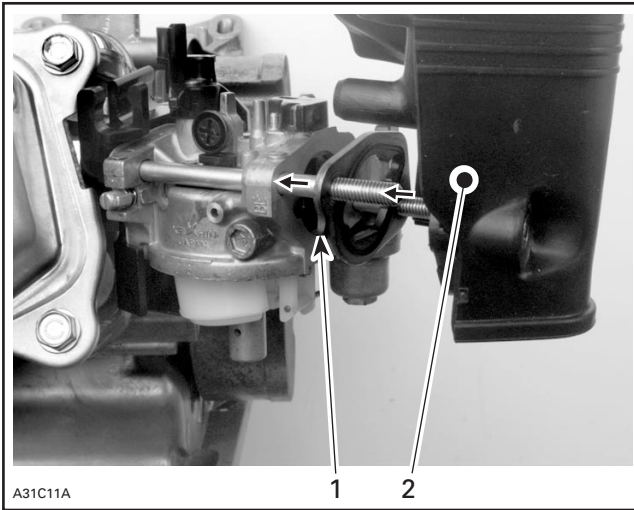

1. Spacer
2. Air cleaner elbow ass'y

## CARBURETOR ADJUSTMENTS

### Preliminary Idle Speed Adjustment

#### 21, Pilot Screw

Start engine and allow it to warm.

Adjust idle speed by turning pilot screw **no. 21** clockwise or counterclockwise until highest idle RPM is attained.

### Idle Speed Final Adjustment

#### 15, Throttle Stop Screw

After the pilot screw is correctly adjusted, turn throttle stop screw **no. 15** to obtain the standard idle speed.

STANDARD IDLE SPEED	1400 ± 200 RPM
------------------------	----------------

## GOVERNOR ADJUSTMENT

Loosen governor arm nut.

Turn governor arm clockwise until carburetor throttle is fully opened. Hold governor arm in this position.

Using pliers, turn governor arm shaft clockwise until it stops.

At this point tighten governor arm nut. See the next photo.

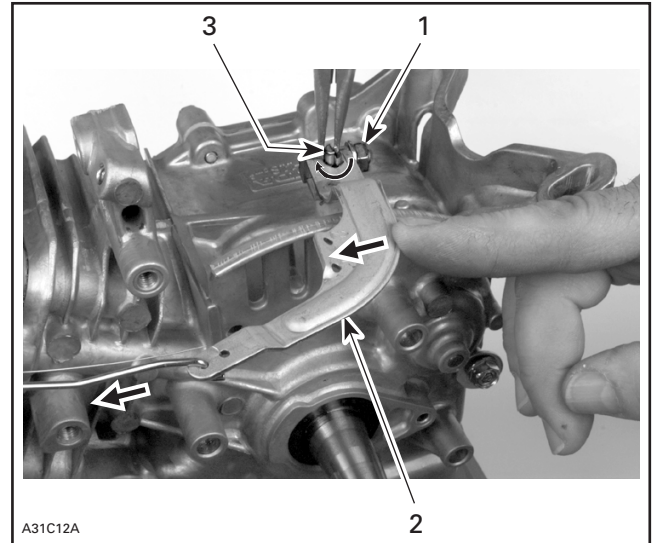

1. Governor arm nut
2. Turn governor arm to fully open throttle
3. Turn governor arm shaft

Lift rear of snowmobile.

Start engine and allow to warm up to normal temperature.

Activate throttle lever so that engine revs to maximum standard speed.

Adjust throttle lever stop screw so that engine will not rev over maximum standard speed. Refer to TECHNICAL DATA 10-02.

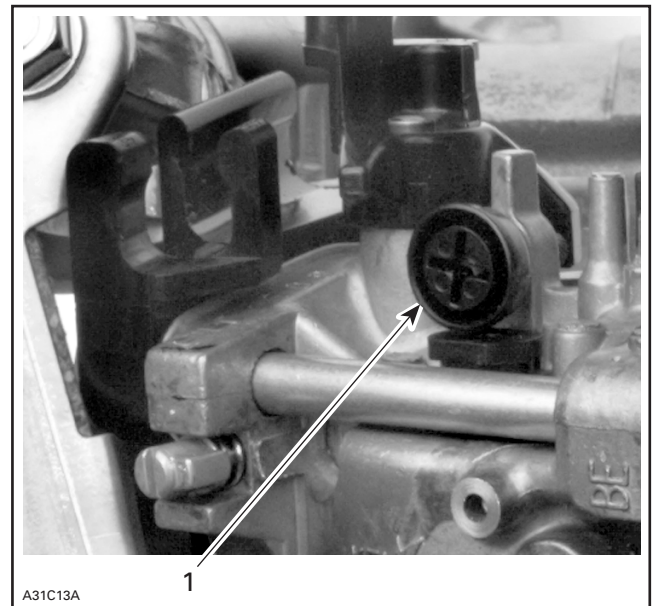

1. Adjust throttle lever stop screw



# FUEL TANK AND THROTTLE CABLE

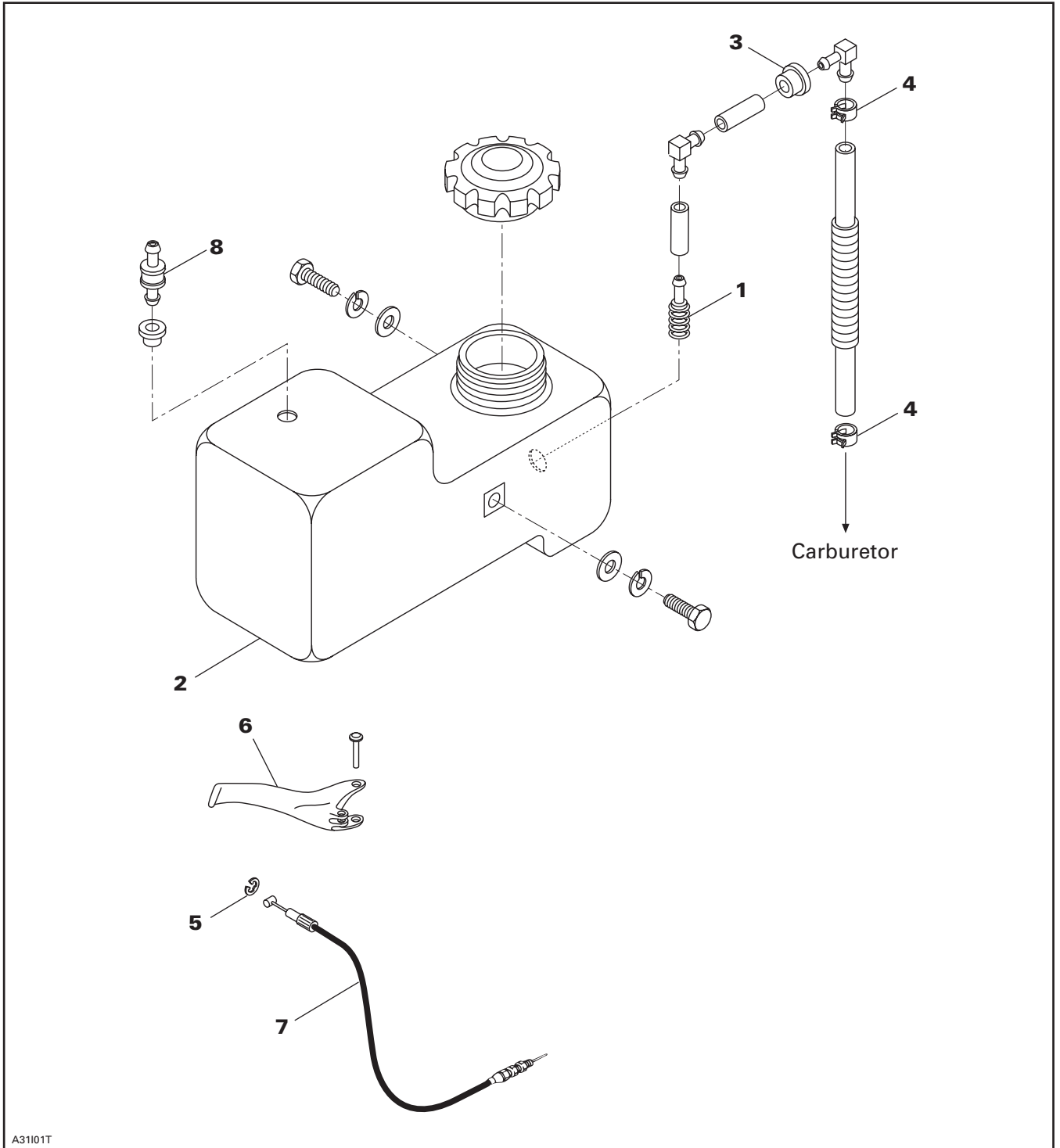

## Section 04 ENGINE

### Subsection 09 (FUEL TANK AND THROTTLE CABLE)

#### Fuel Tank Lines

#### WARNING

When draining a fuel tank or whenever a fuel line is disconnected, obstruct line with a hose pincher (P/N 295 000 076) or equivalent device. Fuel is flammable and explosive under certain conditions. Ensure work area is well ventilated. Do not smoke or allow open flames or sparks in the vicinity.

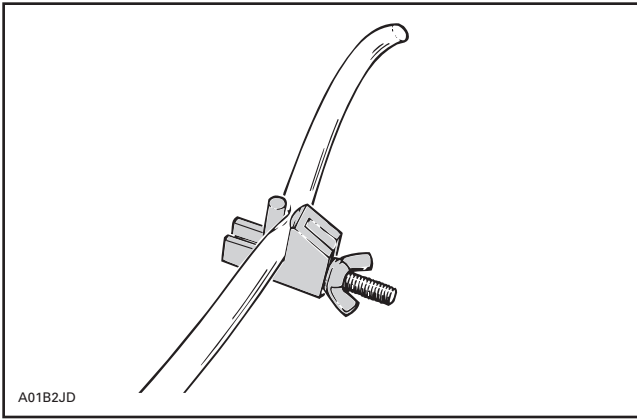

#### 8, Check Valve

Check valve **no. 8** must be installed with its black side (stamped VAC) facing toward fuel tank.

To check proper operation of check valve, apply vacuum to nipple of black side (stamped VAC). There must be no air flow restriction.

With 35 kPa (5 PSI) applied to nipple of black side (stamped VAC) the check valve should not lose more than 2 bubbles per minute at either nipple or at the weld joint while submersed in water.

Replace if check valve doesn't meet above mentioned specifications.

#### Fuel Filter

To remove fuel filter **no. 1** from fuel tank **no. 2**, first drain fuel tank.

Using a flat screwdriver, carefully pull out fuel filter by removing grommet **no. 3**, as shown in the next photo.



#### REMOVE GROMMET

Ensure that fuel filter and fuel line are clean and not damaged, as per following photo.

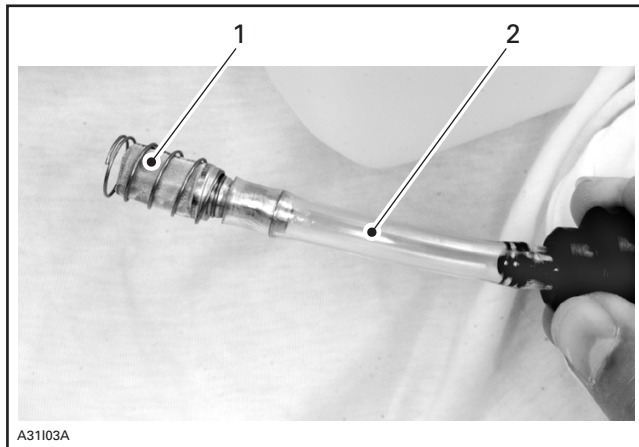

1. Fuel filter
2. Fuel line

Reinstall fuel filter with grommet.

Refuel tank and ensure there are no leaks.

#### Fuel Line Spring Clips

Always reposition spring clips **no. 4** after any repair to prevent possible leaks.

### Throttle Cable Circlip at Handlebar

Put silicone grease (P/N 413 701 700) around cable barrel of throttle cable no. 7. Locate circlip no. 5 as per following photo.

#### WARNING

If this procedure is disregarded, throttle lever no. 6 might be half-open at normally closed position and the engine will speed up when starting.

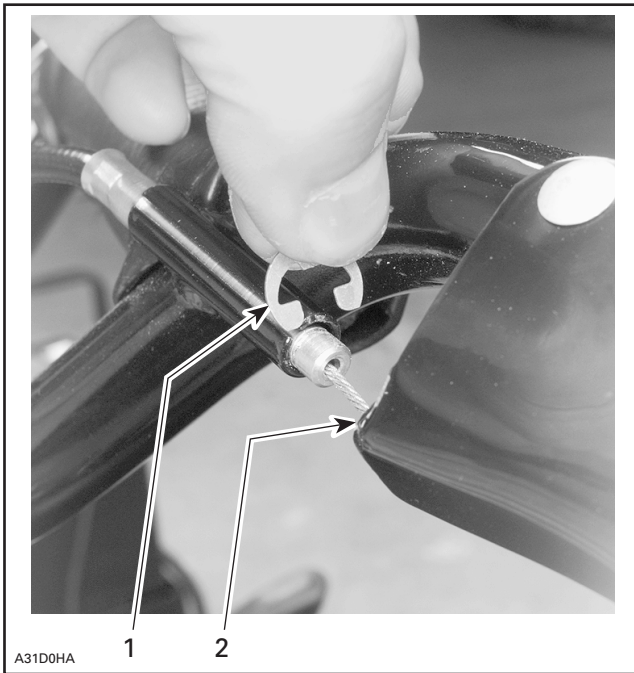

TYPICAL — BRAKE SIDE SHOWN, IDENTICAL FOR THROTTLE SIDE

1. Circlip
2. Detach throttle cable from throttle lever

### Throttle Cable Routing

**CAUTION:** Check that throttle cable is routed away from sharp edges, hot or vibrating parts. When turning steering while engine is running, idle speed must not vary.

### Throttle Cable Adjustment

Loosen throttle cable at carburetor.

While holding handlebar throttle lever and carburetor lever at full throttle, tighten throttle cable to this position.

#### WARNING

Ensure that engine is not running when adjusting throttle cable.