



**REAR SUSPENSION
FRONT ARM STOPPER STRAP
(P/N 860 305 900)**

⚠ WARNING

For safety reasons, this kit must be installed by an authorized Bombardier snowmobile dealer. Should removal of a locking device (e.g. lock tabs, self-locking fasteners, etc.) be required when undergoing disassembly/assembly, always replace with a new one. This instruction sheet should be given to the purchaser. This kit is designed for specific applicable models only. It is not recommended for units other than those for which it was sold.

NOTE: Installation time is approximately 0.8 hour.

PARTS TO BE INSTALLED

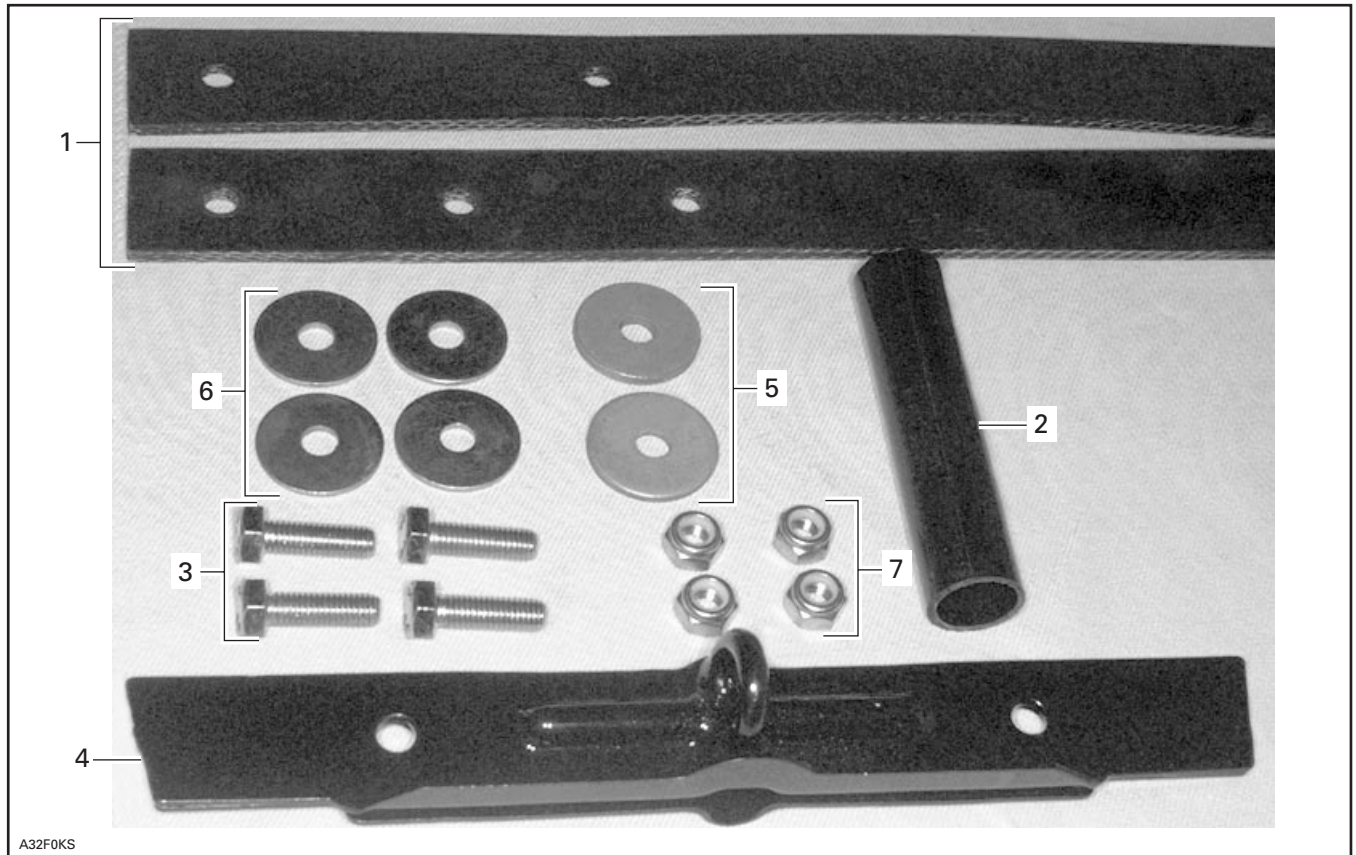

A32F0KS

- | | |
|------------------------|---------------------------|
| 1. Stopper Strap (2) | 5. Thick Flat Washer (2) |
| 2. Spacer | 6. Thin Flat Washer (4) |
| 3. Hexagonal Screw (4) | 7. Elastic Stop Nut (4) |
| 4. Bracket | 8. Cotter Pin (not shown) |

INSTRUCTIONS

Lift rear of vehicle and support it off the ground.

Loosen track tension and remove rear suspension complete by removing front and rear arm upper tube bolts on each side (shown on next photos).

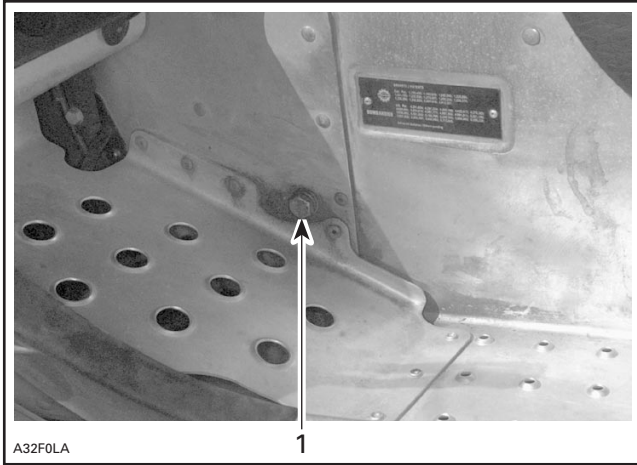

1. Unscrew this bolt on both sides

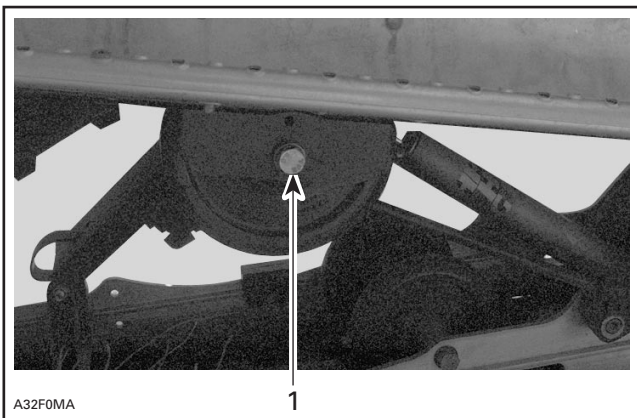

1. Unscrew this bolt on both sides

Install suspension on a bench and cut both front arm straps at their front seam.

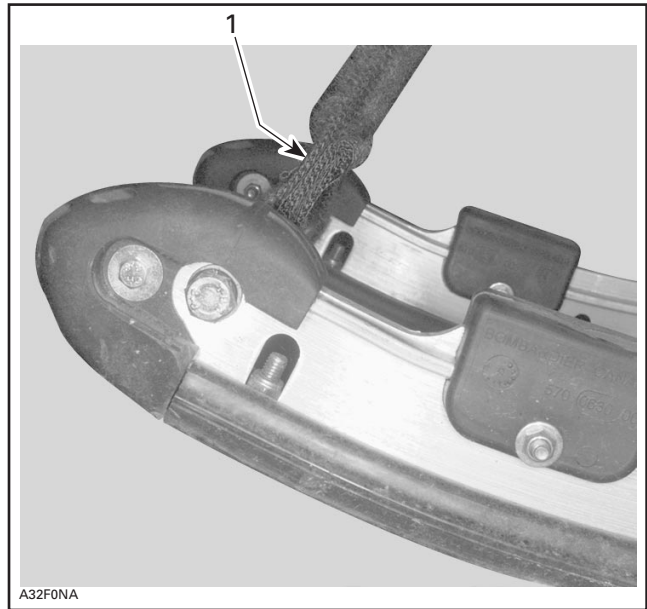

1. Cut straps at their seam

Remove what remains of both straps.

Unscrew quick adjustment knob completely, keep flat washer, it will be reused with adjustment knob.

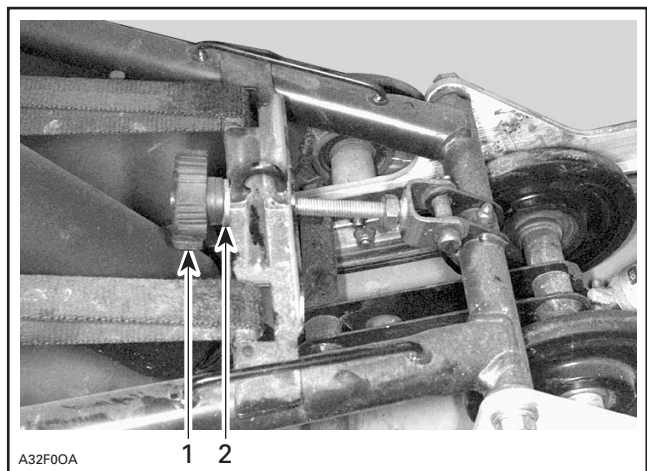

1. Unscrew adjustment knob completely
2. Keep this flat washer

Unscrew front axle bolts and remove front axle.

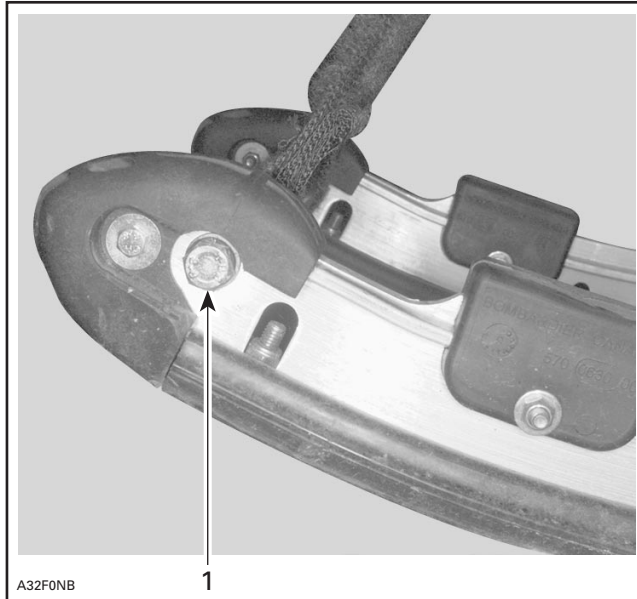

1. Unscrew this bolt on both sides

Remove existing front axle plastic spacer, keep 2 smaller spacers.

Install new plastic spacer **no. 2** and two smaller spacers on axle and reinstall axle. Apply Loctite 271 on bolts and torque to 23 N•m (17 lbf•ft).

Remove adjustment screw cotter pin in order to release it from lower tube and be able to replace bracket.

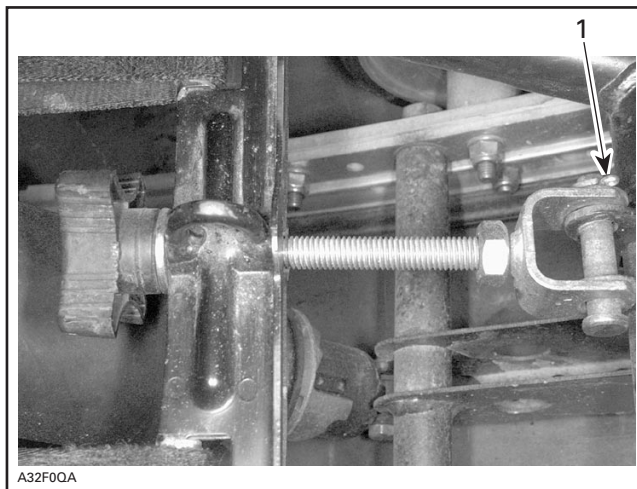

1. Remove this cotter pin

Remove bracket.

Install new bracket **no. 4** with loop upward and angle edge at rear; secure adjustment screw to lower tube using new cotter pin **no. 8**.

Install washer and adjustment knob to retain bracket to adjustment screw.

Secure each strap **no. 1** around axle; note that strap end with 2 holes goes around axle. Secure each strap with hexagonal screw **no. 3**, two thin flat washers **no. 6** and elastic stop nut **no. 7**. Tighten nuts to 7 N•m (62 lbf•in).

Pass other end of straps through small bridges on arm upper tube and align their first hole with bracket holes. Note that strap goes under bracket.

Secure each strap to bracket with hexagonal screw **no. 3**, thick flat washer **no. 5** and elastic stop nut **no. 7**. Tighten nuts to 21 N•m (15 lbf•ft).

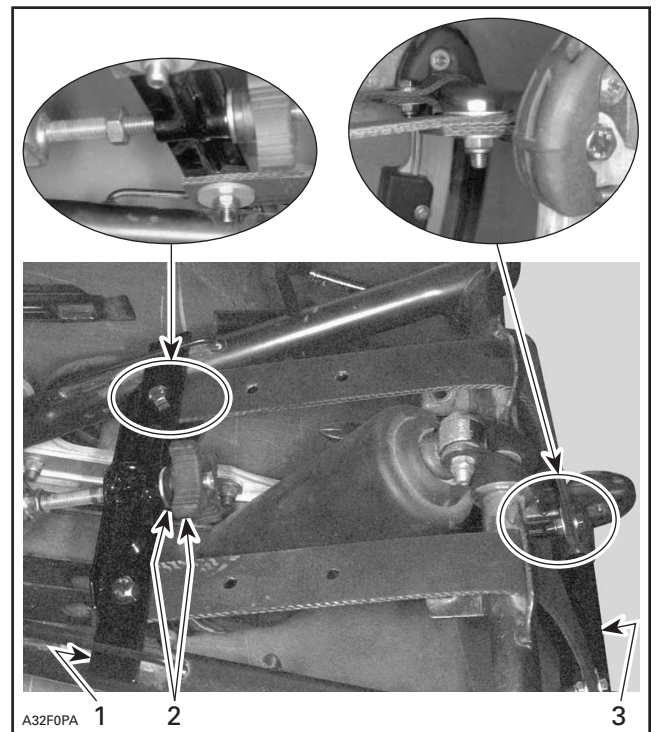

1. New bracket
2. Flat washer and adjustment knob
3. Axle

Reinstall suspension on snowmobile.

Perform track adjustment as per procedure in appropriate *Shop Manual*.

860 305 900

| | | | |
|----|-------------|------------------------|---------------------------------|
| 1. | 503 189 450 | Stopper Strap (2) | Courroie d'arrêt (2) |
| 2. | 503 189 265 | Spacer | Entretoise |
| 3. | 207 182 544 | Hexagonal Screw (4) | Vis hexagonale (4) |
| 4. | 503 188 400 | Bracket | Support |
| 5. | 503 183 100 | Thick Flat Washer (2) | Rondelle plate épaisse (2) |
| 6. | 224 081 301 | Thin Flat Washer (4) | Rondelle plate mince (4) |
| 7. | 232 581 600 | Elastic Stop Nut (4) | Écrou d'arrêt élastique (4) |
| 8. | 371 801 000 | Cotter Pin (not shown) | Goupille fendue (non illustrée) |