



**TEMPERATURE GAUGE KIT
(P/N 861 771 100)**

◆ WARNING

For safety reasons, this kit must be installed by an authorized Bombardier snowmobile dealer. Should removal of a locking device be required when undergoing disassembly/assembly, always replace with a new one. This instruction sheet should be given to the purchaser. This kit is designed for specific applicable models only. It is not recommended for units other than those for which it was sold.

NOTE: Installation time is approximately 0.5 hour.

PARTS TO BE INSTALLED

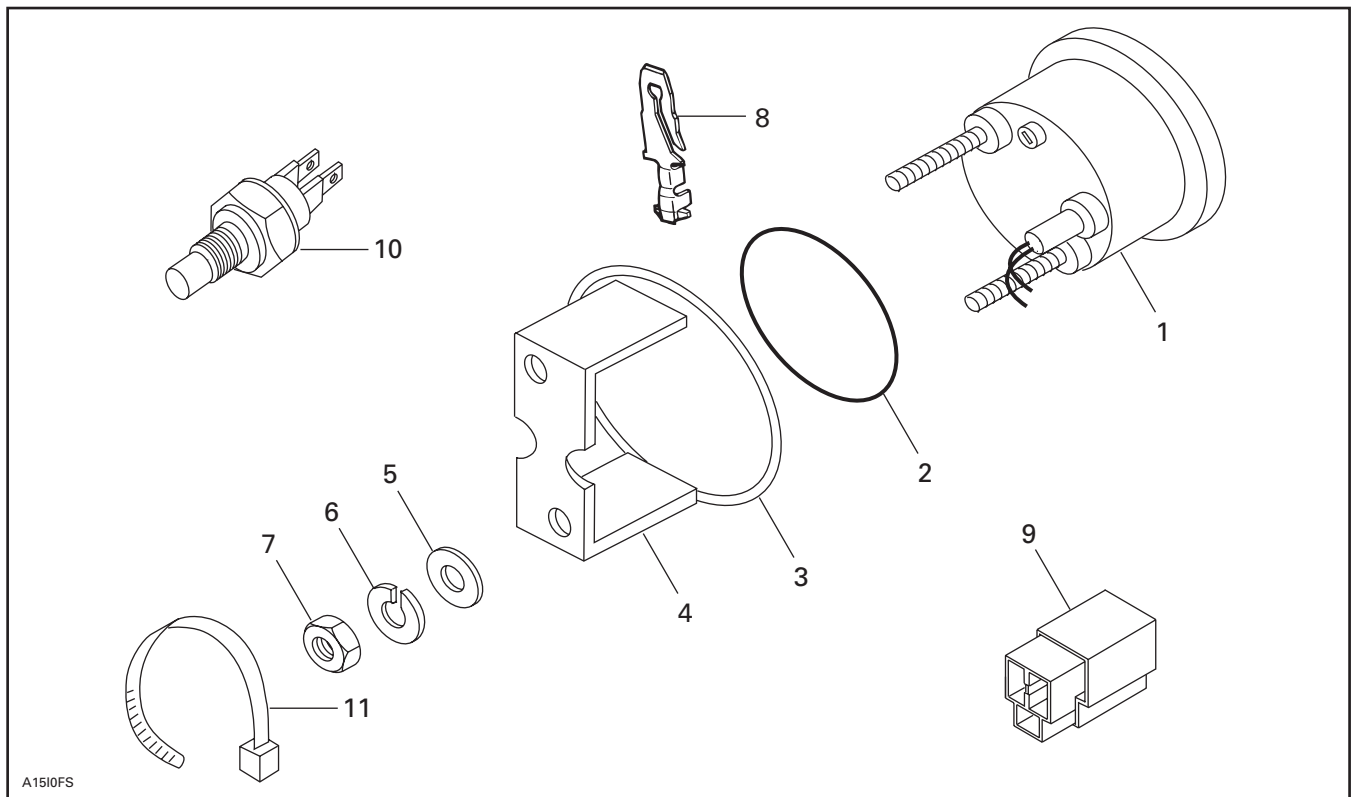

- 1. Temperature Gauge
- 2. Gauge Packing
- 3. Formed Washer
- 4. Gauge Holder
- 5. Flat Washer (2)
- 6. Lock Washer (2)
- 7. Nut (2)
- 8. Male Terminal (3)
- 9. 3-Connector Male Housing
- 10. Temperature Sensor
- 11. Locking Tie

Temperature Sender

◆ WARNING

This procedure must be performed when engine is cold and turned off.

Remove air box.

Remove intake resonator and block holes with a clean piece of rag.

Disconnect connectors from temperature sender on engine.

Apply pipe sealant (P/N 413 702 300) on threads of new sensor **no. 10**.

NOTE: The new sender is a variable resistor instead of a thermo-switch.

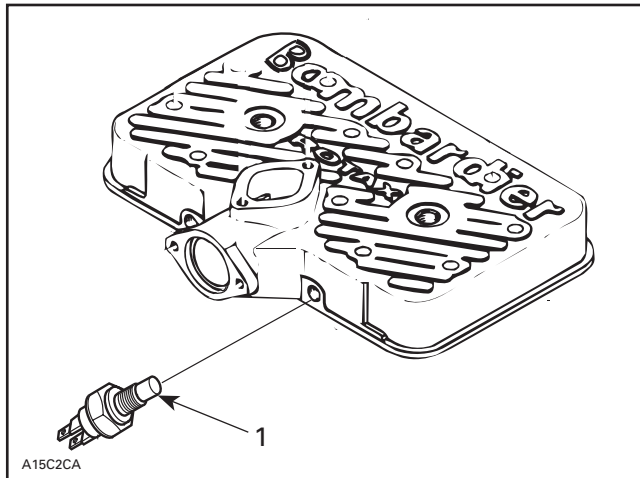

TYPICAL

1. Sender

Unscrew sensor from engine and quickly block hole with your finger until ready to install new sensor.

Install new sensor.

Torque sensor to 6 N•m (53 lbf•in).

Reconnect connectors (polarity is not important).

Remove piece of rag and reinstall intake resonator.

Temperature Gauge

Remove air intake plate from underneath hood.

Position template (supplied on last page of this instruction sheet) over left side dashboard plate to locate center of hole. Using a hole saw, drill a 63.5 mm (2.5 in) hole in dashboard plate.

▼ CAUTION

Make sure there are no wires behind dashboard in order to avoid any damages.

Install male terminals **no. 8** on wires and position in 3-connector housing **no. 9** as per the following illustration.

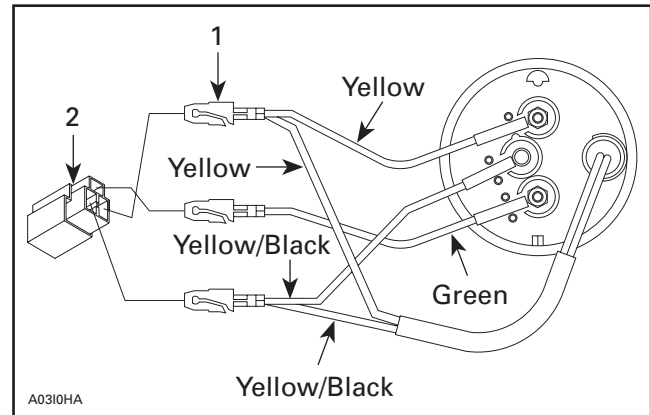

1. Male terminal
2. 3-connector housing

Install gauge packing **no. 2** on temperature gauge **no. 1** then insert into dashboard.

Install formed washer **no. 3** then gauge holder **no. 4**.

Install flat washers **no. 5**, lock washers **no. 6** and tighten with nuts **no. 7**.

Connect housing.

Secure gauge harness with locking tie **no. 11**.

▼ CAUTION

Disconnect temperature indicator warning lamp wire. If this is not done, none of the indicator lamp or temperature gauge will function properly.

Hide indicator lamp wire by taping its connector onto harness.

Reinstall air intake plate.

Test gauge operation and ensure there are no fluid leaks at sender.

Replenish cooling system if necessary.

DRILLING TEMPLATE

Use this template to properly drill hole for gauge in dashboard.

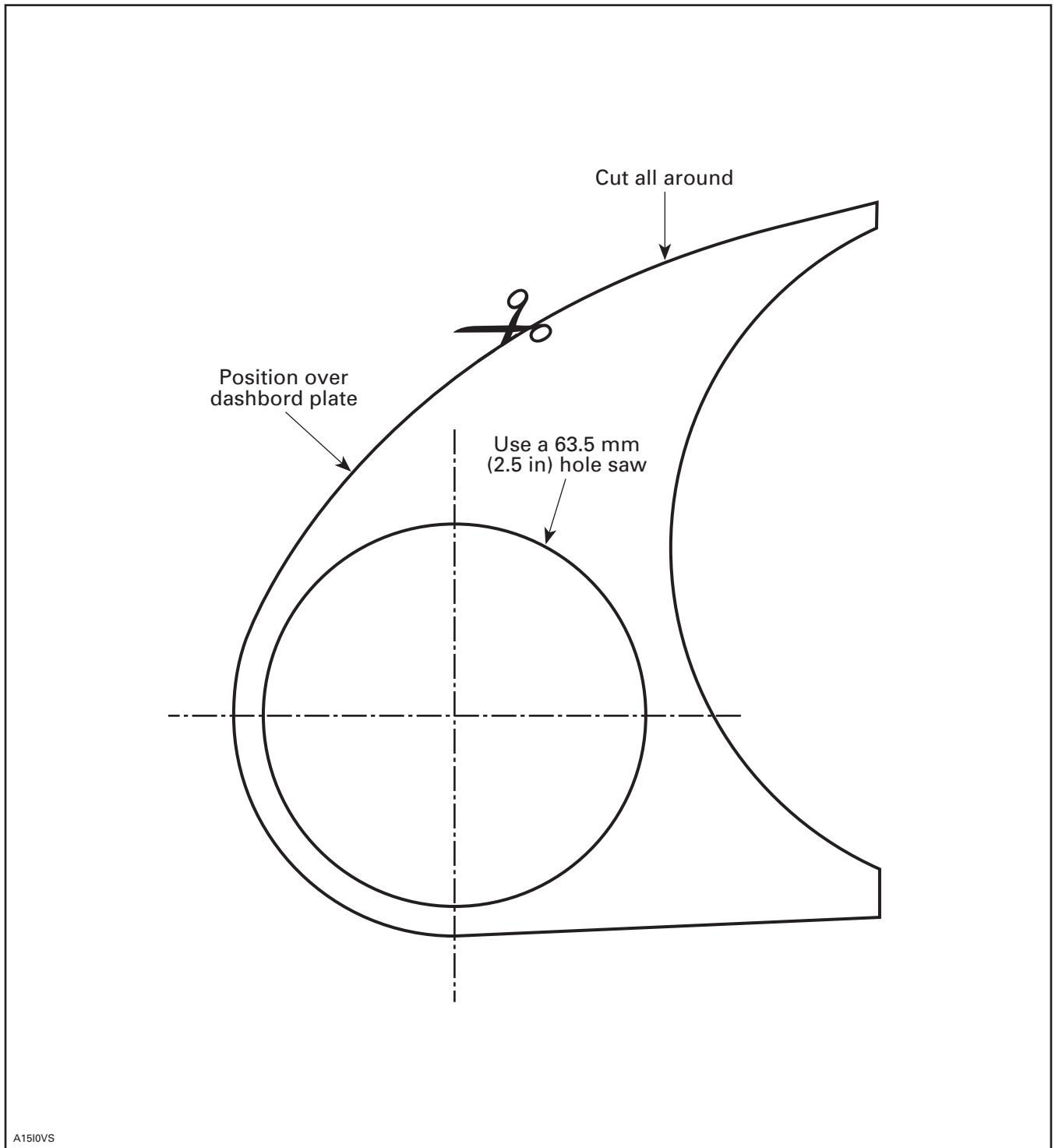

861 771 100

1.	515 175 440	Temperature Gauge	Indicateur de température
2.	414 807 200	Gauge Packing	Joint torique
3.	517 258 600	Formed Washer	Rondelle formée
4.	415 099 800	Gauge Holder	Support d'indicateur
5.	414 833 800	Flat Washer (2)	Rondelle plate (2)
6.	414 833 700	Lock Washer (2)	Rondelle-frein (2)
7.	414 833 600	Nut (2)	Écrou (2)
8.	561 503 400	Male Terminal (3)	Borne mâle (3)
9.	409 204 200	3-Connector Male Housing	Logement de raccords mâle à 3 circuits
10.	414 728 700	Temperature Sensor	Sonde de température
11.	414 115 200	Locking Tie	Attache