



◆ WARNING

For safety reasons, this kit must be installed by an authorized Bombardier snowmobile dealer. Should removal of a locking device be required when undergoing disassembly/assembly, always replace with a new one. This instruction sheet should be given to the purchaser. This kit is designed for specific applicable models only. It is not recommended for units other than those for which it was sold.

NOTE: Installation time is approximately 0.5 hour.

PARTS TO BE INSTALLED

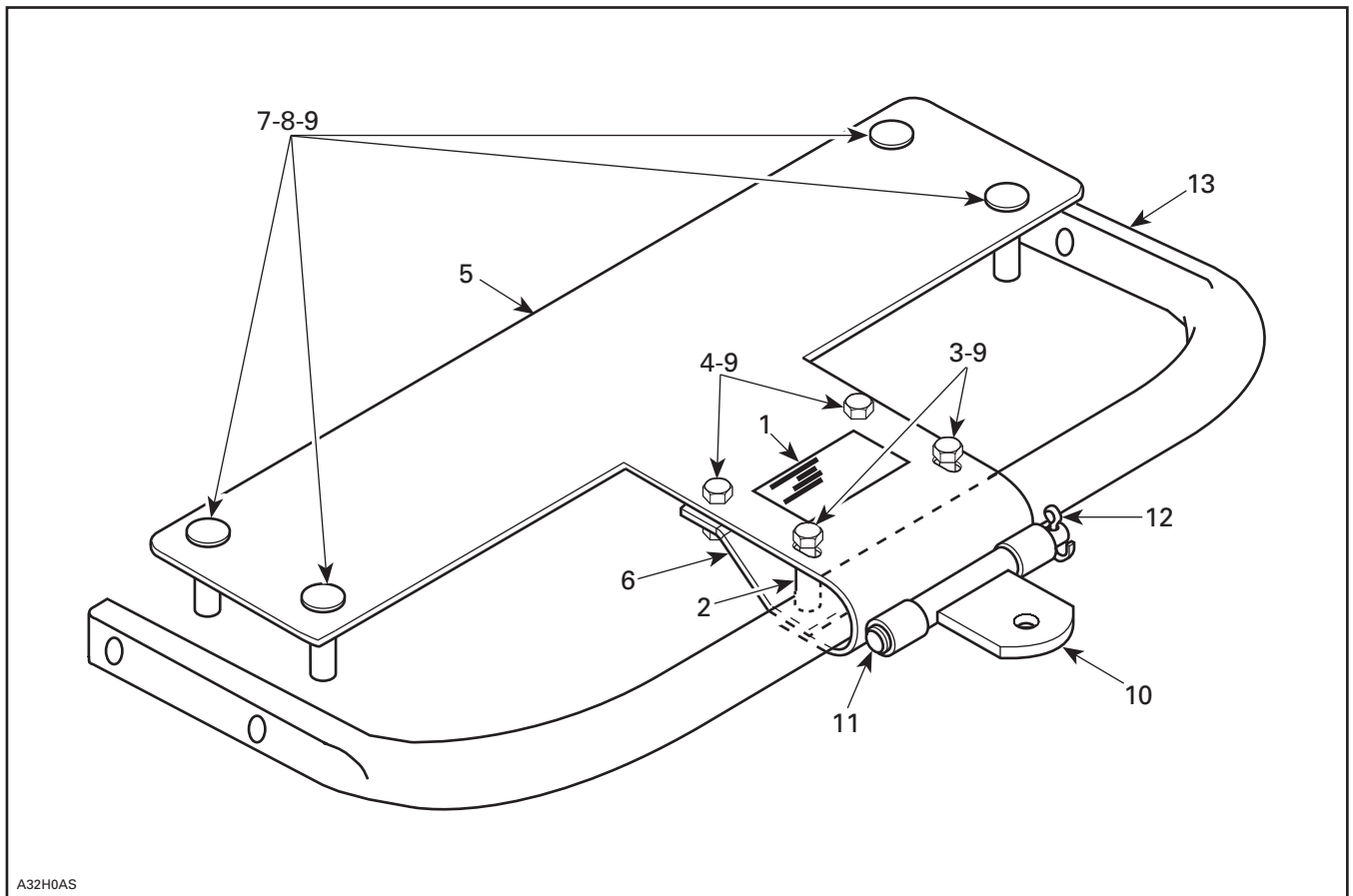

- 1. Label
- 2. Spacer (2)
- 3. Bolt M6 x 50 (2)
- 4. Bolt M6 x 18 (2)
- 5. Support
- 6. Reinforcement Plate
- 7. Carriage Bolt M6 x 20 (4)

- 8. Flat Washer (4)
- 9. Nut M6 (8)
- 10. Hitch Plate
- 11. Clevis Pin
- 12. Cotter Pin
- 13. Bumper

PROCEDURE

Remove seat (short tunnel model only).

Remove both rear side moldings.

Remove rear bumper. Keep bolts and nuts.

Cut rear snowguard along inside guidelines and remove plastic tab to provide hitch opening.

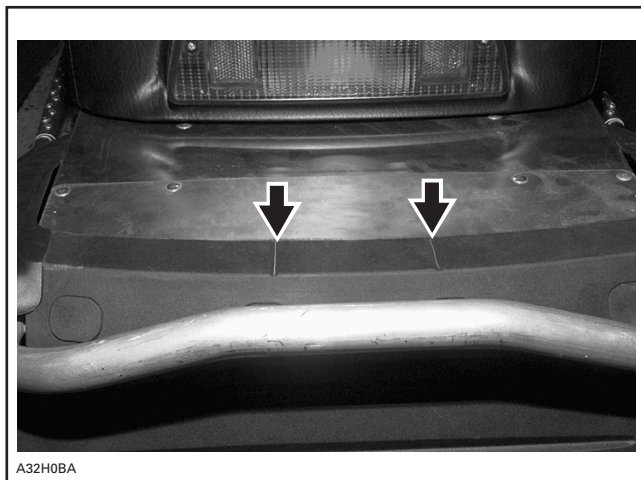

CUT ALONG THESE MARKS

Install new rear bumper **no. 13**.

Using support holes as guide, drill through the tunnel using a 6.5 mm (1/4 in) drill bit. To position support correctly, make the support hang on bumper and lay in snowguard opening. See photo.

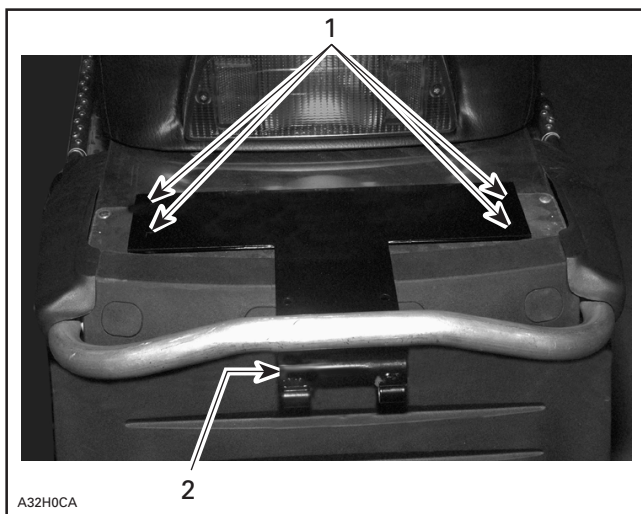

TYPICAL

1. Pre-drilled holes
2. The provided bumper should pass through the support hook

▼ CAUTION

Care must be taken to drill only in designated areas. Damage to the heat exchangers could occur if drilling outside this area.

Install reinforcement plate **no. 6** with support **no. 5**, spacers **no. 2**, bolts **no. 3** and bolts **no. 4**. Secure with nuts **no. 9** and tighten.

Secure support **no. 5** with carriage bolts **no. 7**, flat washers **no. 8** and nuts **no. 9**. Tighten all bolts.

Install hitch plate **no. 10** with clevis pin **no. 11** and cotter pin **no. 12**.

Reinstall rear moldings and seat.

NOTE: Make sure hitch plate swings freely on hitch bracket.

Affix warning label **no. 1** to hitch.

NOTE: A hook-type hitch kit (P/N 861 722 500) is available for converting the present kit.

860 702 800

1.	414 998 500	Label	Étiquette
2.	517 191 700	Spacer (2)	Entretoise (2)
3.	207 065 044	Bolt M6 x 50 (2)	Boulon M6 x 50 (2)
4.	207 161 844	Bolt M6 x 18 (2)	Boulon M6 x 18 (2)
5.	511 000 030	Support	Support
6.	511 000 022	Reinforcement Plate	Plaque de renfort
7.	207 762 044	Carriage Bolt M6 x 20 (4)	Boulon de carrosserie M6 x 20 (4)
8.	224 061 201	Flat Washer (4)	Rondelle plate (4)
9.	232 561 414	Nut M6 (8)	Écrou M6 (8)
10.	517 008 700	Hitch Plate	Plaque d'attelage
11.	505 001 700	Clevis Pin	Axe de chape
12.	371 800 200	Cotter Pin	Goupille fendue
13.	517 243 800	Bumper	Pare-chocs