



◆ WARNING

For safety reasons, this kit must be installed by an authorized Bombardier snowmobile dealer. Should removal of a locking device be required when undergoing disassembly/assembly, always replace with a new one. This instruction sheet should be given to the purchaser. This kit is designed for specific applicable models only. It is not recommended for units other than those for which it was sold.

NOTE: Installation time is approximately 0.5 hour.

PARTS TO BE INSTALLED

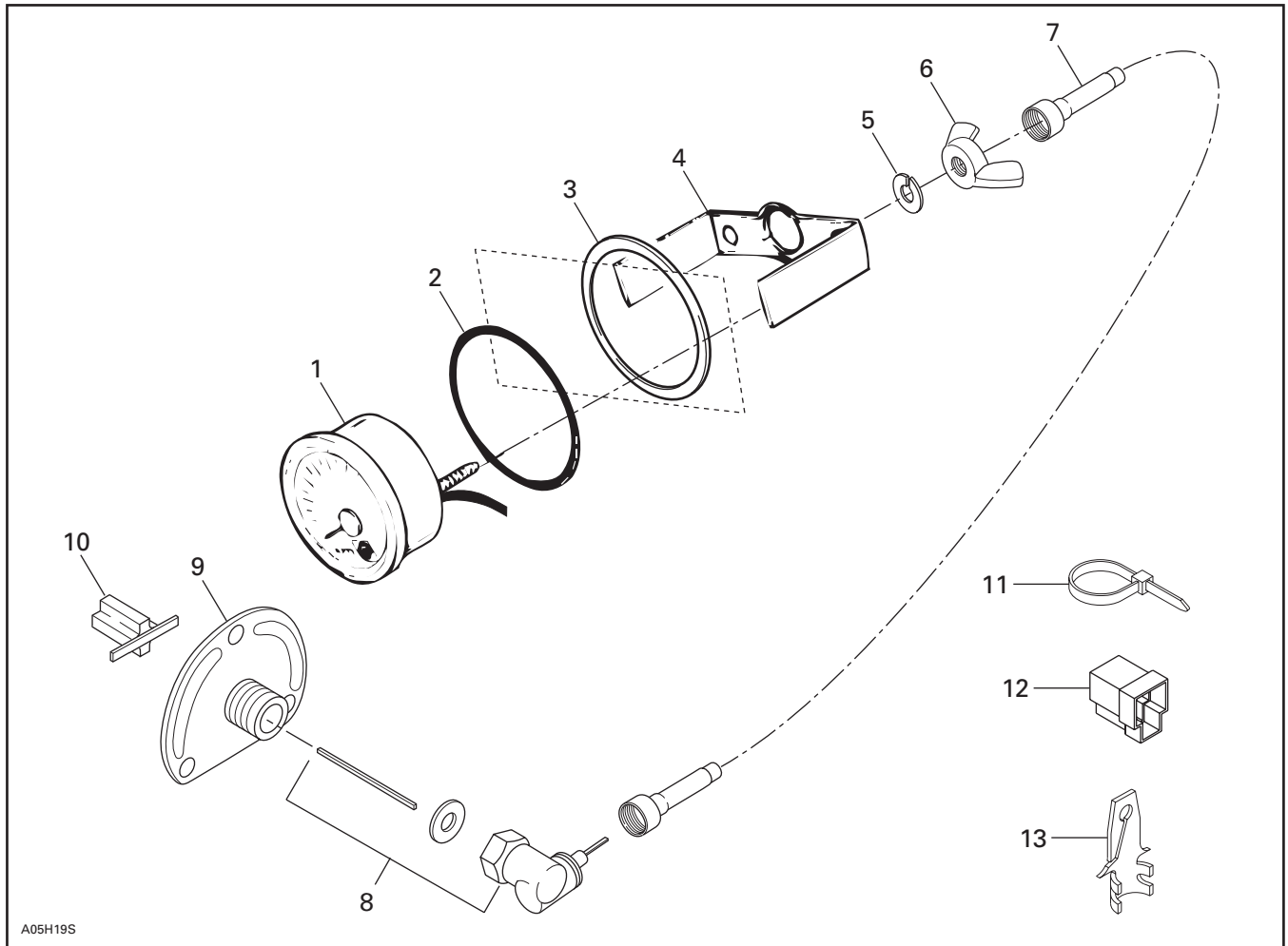

- | | |
|-----------------------|---|
| 1. Speedometer | 9. End Bearing Housing |
| 2. Gauge Packing | 10. Drive Insert |
| 3. Ring | 11. Locking Tie(4) |
| 4. Gauge Holder | 12. 2-Connector Housing |
| 5. Lock Washer M5 (2) | 13. Male Connector (2) |
| 6. Wing Nut M5 (2) | 14. Reset Button (assembly) (not shown) |
| 7. Speedometer Cable | 15. Clip (not shown) |
| 8. Angle Drive | 16. Speed Drive (not shown) |

DASHBOARD PREPARATION

Lift hood.

Locate center mark as shown in the following illustration.

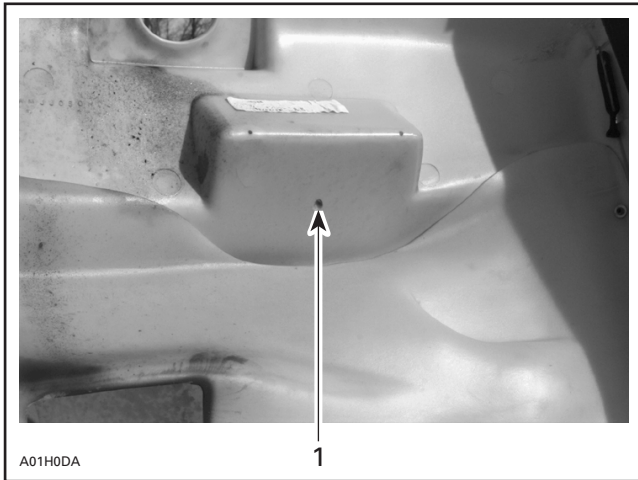

VIEW FROM INSIDE HOOD

1. Center mark

From inside hood, position an 80 mm (3-1/8 in) hole saw over center mark.

Drill hole through dash.

SPEEDOMETER INSTALLATION

Install male connectors **no. 13** on gauge wires and position in 2-connector housing **no. 12**.

Ensure that the gauge wires correspond to vehicle wires as per the following table.

GAUGE HARNESS	VEHICLE HARNESS
YELLOW/BLACK	YELLOW/BLACK
RED/YELLOW	YELLOW

Install gauge packing **no. 2** onto speedometer **no. 1**.

From outside hood, install speedometer into dashboard hole.

From inside hood, install ring **no. 3** then gauge holder **no. 4**.

Secure assembly with lock washers **no. 5** and wing nuts **no. 6**.

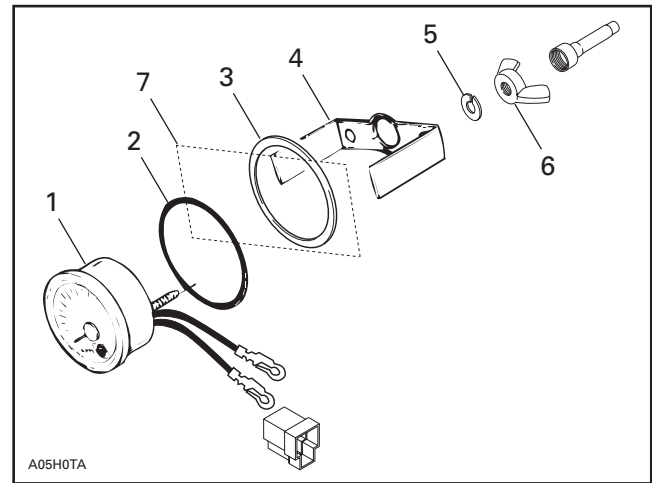

1. Speedometer
2. Gauge packing
3. Ring
4. Gauge holder
5. Lock washer
6. Wing nut
7. Dashboard

Cut locking tie retaining vehicle connector housings to headlight screw.

Connect housings.

Secure wires with locking tie **no. 11**, at headlight screw location.

ANGLE DRIVE AND END BEARING HOUSING INSTALLATION

Remove muffler.

Release track tension.

To ease end bearing housing installation **no. 9**, support drive axle with drive axle holder (P/N 529 007 200).

Remove existing end bearing housing on the right side of frame and discard it.

NOTE: There may be a washer(s) inside existing end bearing housing. If so, keep washer(s) for new end bearing installation.

Using a fiber hammer, tap drive insert **no. 10** into drive axle hole.

Install the new end bearing housing. Torque screws to 10 N•m (89 lbf•in).

Push cable branch key into speedometer drive insert.

Install washer (included with angle drive) and screw angle drive unit **no. 8** onto end bearing housing.

NOTE: Position angle drive downward so that speedometer cable **no. 7** will lean on bottom pan.

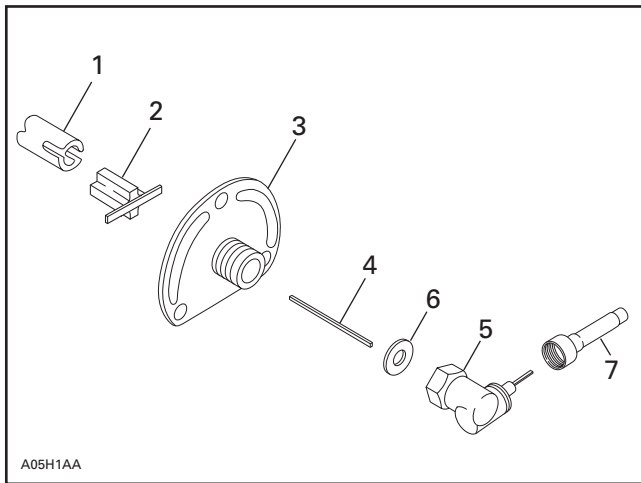

A05H1AA

TYPICAL

1. Drive axle end
2. Drive insert
3. End bearing housing
4. Cable branch key (included with angle drive)
5. Angle drive
6. Washer (included with angle drive)
7. Speedometer cable

SPEEDOMETER CABLE AND WIRING HARNESS ROUTING

Install speedometer cable end to angle drive.
Route speedometer cable from underneath right side cross member.

RESET BUTTON/SPEED DRIVE

From inside hood, install speed drive no.16 and then reset button no. 14 onto speedometer, as shown in the following photo.

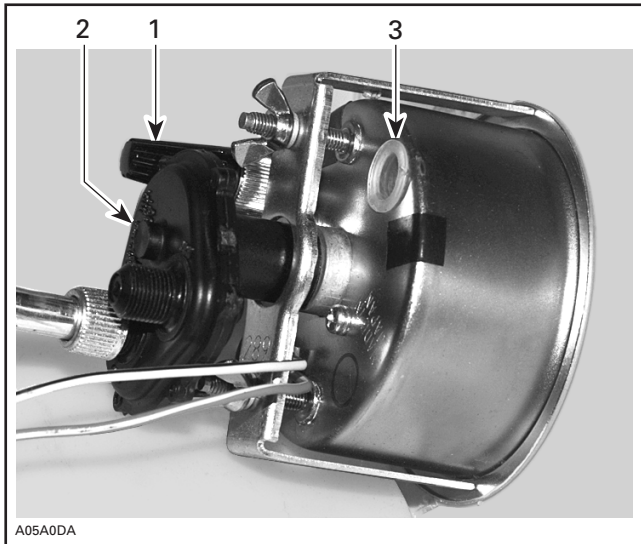

A05A0DA

VIEW FROM INSIDE HOOD

1. Reset button
2. Speed drive
3. Small plastic cap

Screw speed drive to the end, do not tighten, then unscrew just enough to allow installation of the reset button.

NOTE: Speed drive proposes a KPH mode adapter and a MPH mode adapter for the cable. Depending upon the selected mode, remove small plastic cap to slide inner tab to selected mode, using a small flat screw driver. With cable in MPH mode, MPH must show on the face of the gauge and so on.

Install speedometer cable end to the selected mode on speed drive.

Reinstall muffler.

Secure speedometer cable with clip no. 15 using left front bumper screw, as shown in the following photo.

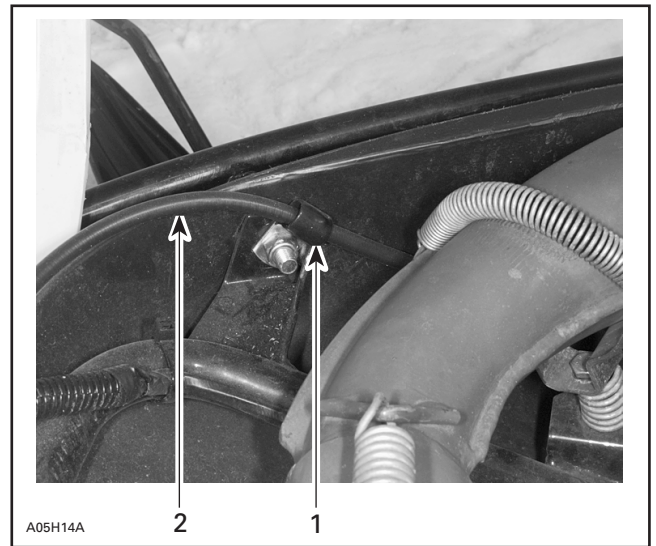

A05H14A

1. Clip
2. Speedometer cable

Drill a 6 mm (1/4 in) hole in hood retaining wire tab, then attach wiring harness and speedometer cable with locking tie no. 11, as shown in the following photo.

▼ **CAUTION**

Carefully check speedometer and throttle cable routing to avoid contact with muffler while closing hood.

TRACK TENSION

Readjust track tension previously released, as described in section ANGLE DRIVE AND END BEARING HOUSING INSTALLATION.

To adjust track tension, refer to proper section in appropriate *Shop Manual*.

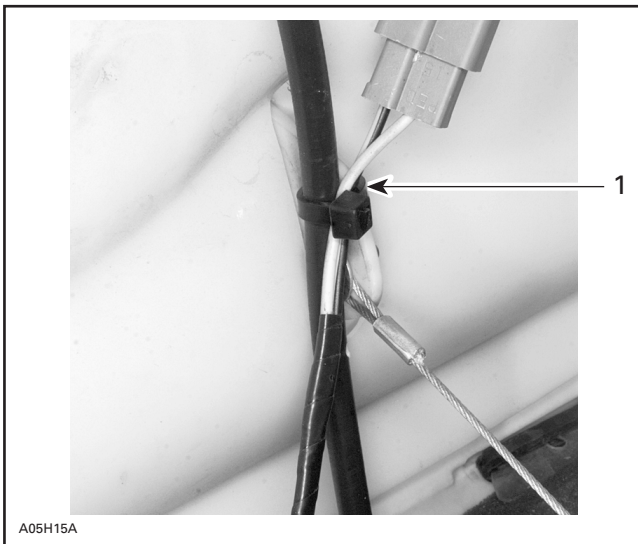

1. Drill a 6 mm (1/4 in) hole to hold locking tie

Attach wiring harness using remaining locking ties.

Refer to the following illustration for locking ties and clip location.

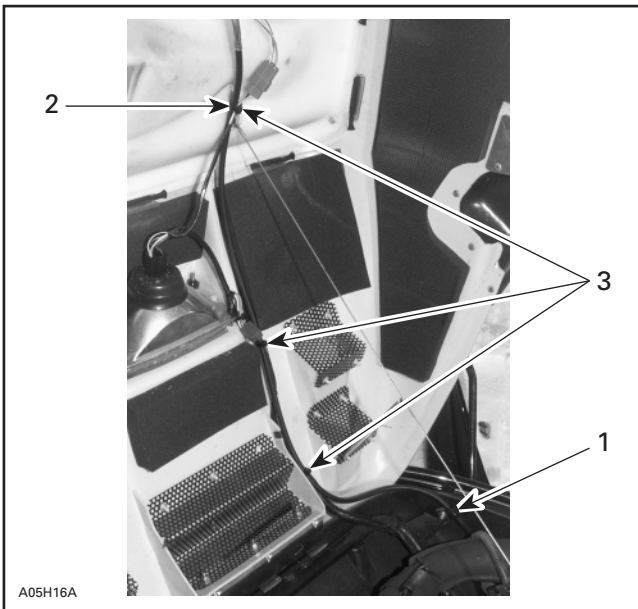

1. Clip
2. Drill a 6 mm (1/4 in) hole
3. Locking ties location

861 769 700

1.	414 682 000	Speedometer	Indicateur de vitesse
2.	414 187 200	Gauge Packing	Joint torique
3.	414 187 300	Ring	Anneau
4.	414 187 400	Gauge Holder	Support d'indicateur
5.	399 802 300	Lock Washer M5 (2)	Rondelle-frein M5 (2)
6.	414 070 300	Wing Nut M5 (2)	Écrou papillon M5 (2)
7.	414 516 500	Speedometer Cable	Câble d'indicateur de vitesse
8.	414 397 800	Angle Drive	Commande angulaire
9.	501 023 900	End Bearing Housing	Logement de palier d'extrémité
10.	572 010 100	Drive Insert	Prise d'indicateur de vitesse
11.	414 115 200	Locking Tie (4)	Attache (4)
12.	409 204 500	2-Connector Housing	Logement à 2 raccords
13.	561 503 400	Male Connector (2)	Raccord mâle (2)
14.	414 487 700	Reset Button (assembly) (not shown)	Bouton de remise à zéro (complet) (non illustré)
15.	414 176 000	Clip (not shown)	Pince (non illustrée)
16.	572 022 300	Speed Drive (not shown)	Commande de vitesse (non illustrée)