



**ELECTRIC STARTER KIT  
(P/N 861 504 400)**

**◆ WARNING**

For safety reasons, this kit must be installed by an authorized Bombardier snowmobile dealer. Should removal of a locking device be required when undergoing disassembly/assembly, always replace with a new one. This instruction sheet should be given to the purchaser. This kit is designed for specific applicable models only. It is not recommended for units other than those for which it was sold.

NOTE: Installation time is approximately 2.5 hours.

**PARTS TO BE INSTALLED**

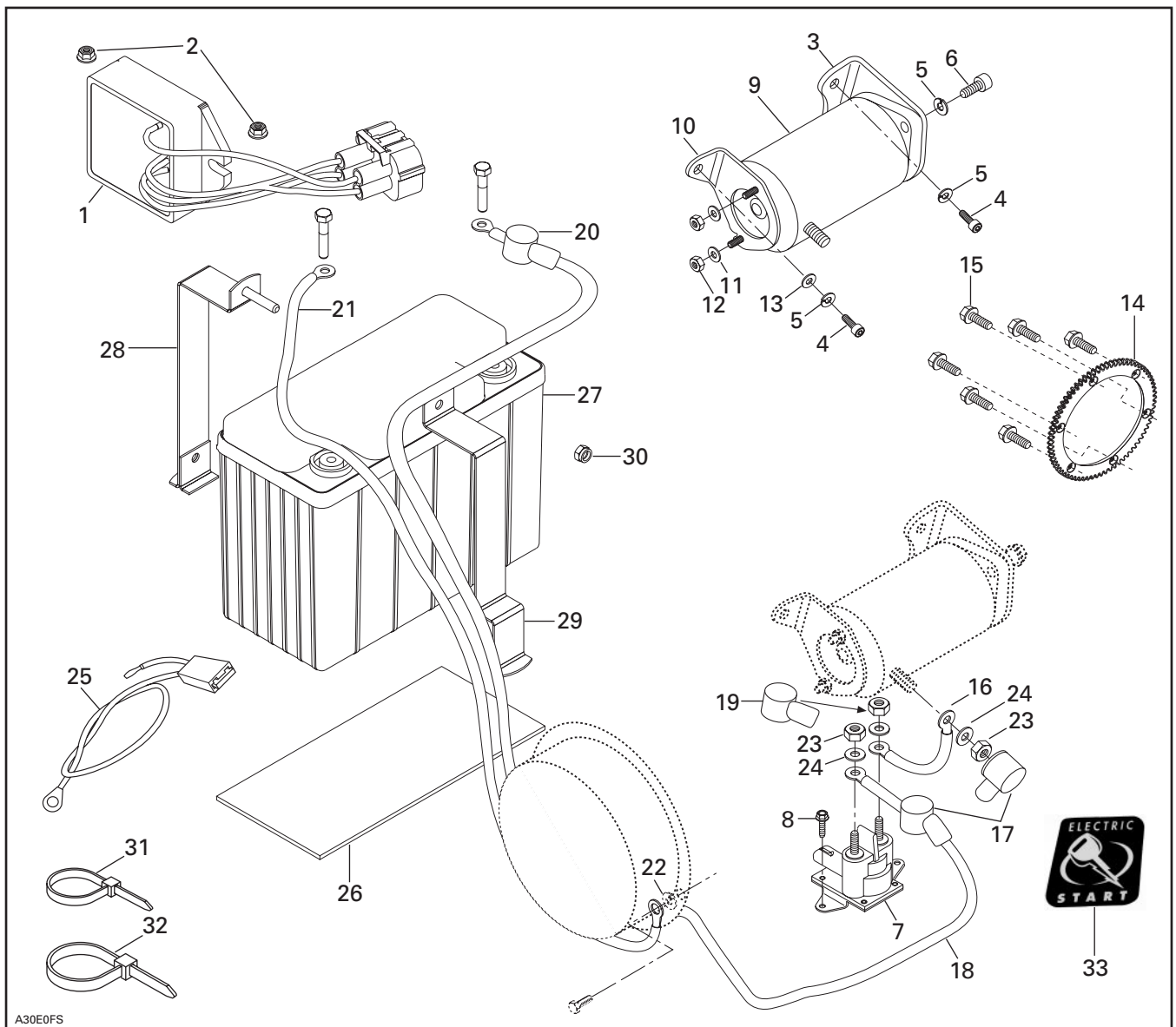

A30E0FS

1. Voltage Regulator
2. Flanged Elastic Nut M6 (2)
3. Starter Support PTO side
4. Socket Screw M8 x 20 (3)
5. Lock Washer M8 (5)
6. Socket Screw M8 x 25 (2)
7. Starter Solenoid
8. Self-Tapping Hexagonal Screw (2)
9. Starter
10. Starter Support MAG Side
11. Flat Washer (2)
12. Flanged Elastic Nut M5 (2)
13. Flat Washer M8
14. Ring Gear
15. Self-Tapping Screw (6)
16. Battery Positive Cable (short)
17. Protector Cap (2)

18. Battery Positive Cable
19. Protector Cap
20. Protector Cap
21. Battery Ground Cable
22. Star Lock Washer (3)
23. Elastic Hexagonal Nut (3)
24. Flat Washer (3)
25. Starting Harness
26. Rubber Strip
27. Battery
28. Rear Steel Strip
29. Front Steel Strip
30. Flanged Elastic Nut M5
31. Locking Tie (8)
32. Locking Tie
33. Decal

---

## INSTRUCTIONS

### Battery Preparation

Prior to electric starter kit installation, battery must be charged. Refer to *Shop Manual* for proper procedure.

 **WARNING**

Never charge or boost battery while connected or installed on vehicle.

### Vehicle Preparation

Close fuel shut off valve.

Remove tuned pipes, muffler, belt guard, drive belt, air intake silencer.

Loosen drive pulley retaining screw for later removal.

### Voltage Regulator

Remove original regulator/rectifier, located along RH side member of frame. Keep retaining bolts. Install voltage regulator **no. 1** and secure with M6 flanged elastic nuts **no. 2** using same retaining bolts.

**NOTE:** Install regulator, with corner where wires come out toward engine.

Connect voltage regulator to vehicle harness making sure, if applicable, that single wire, disconnected from original regulator/rectifier, assures continuity. This is done by reconnecting it to other single wire from vehicle harness (RED/YELLOW male with RED/BLUE female).

### Starter Solenoid

Locate solenoid positioning on metal recess just right of left front engine support. From underneath engine pull out wiring harness enough to cut tie that retains male connector and plug it in female receptacle of solenoid, leaving both threaded posts of solenoid toward front. Using already existing holes, secure solenoid **no. 7** with self-tapping hex. screws **no. 8**.

### Ring Gear

Remove drive pulley. Refer to appropriate *Shop Manual* to perform drive pulley disassembly/assembly procedures and to proceed with pulley alignment.

Secure ring gear **no. 14** on inner half using self-tapping screws **no. 15**. Apply Loctite 271 (red) on screw threads.

 **CAUTION**

Loctite 271 (red) must be applied to safely assemble ring gear.

Torque screws in a criss-cross sequence to 27 N•m (20 lbf•ft).

Do not reinstall drive pulley at this time.

## Ignition Switch

Cut locking tie and unplug switch connector housing from ignition switch. Insert shortest wire of fuse holder **no. 25** inside switch connector housing. Insert connector in position number 7 on switch-connector housing. Reposition connector respecting vehicle connector code as illustrated.

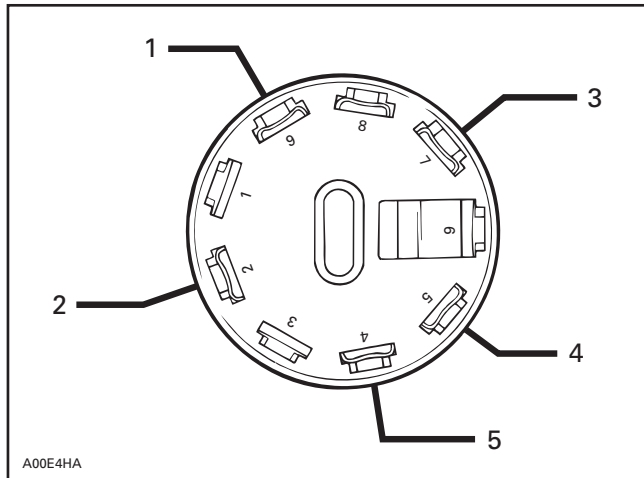

1. RED/GREEN wire to solenoid
2. BLACK/YELLOW
3. RED wire with fuse to battery
4. BLACK
5. RED/BLUE

Replug switch connector housing to ignition switch and secure wires with a locking tie **no. 31** as shown.

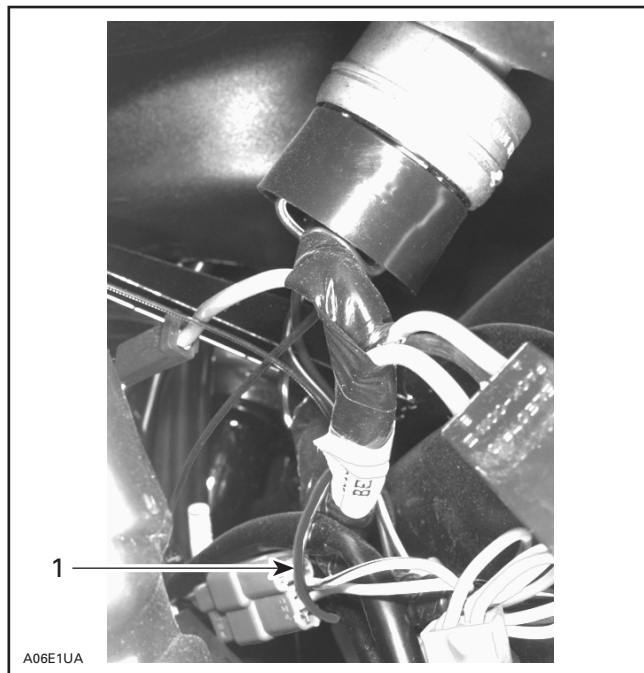

1. Locking tie

## Wire/Cable Connections and Routing

Ensure that all terminals of each battery cable are straight; bend as required.

Starting from battery location, route both cables toward starter location along vehicle harness using existing large clip to start. Refer to following illustrations.

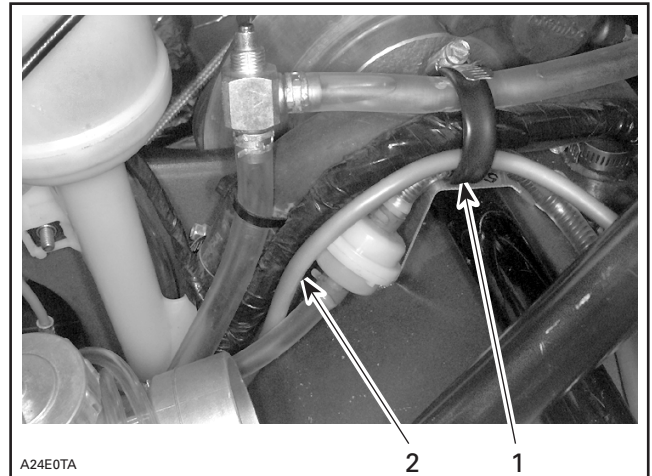

1. Existing large clip
2. Battery positive cable

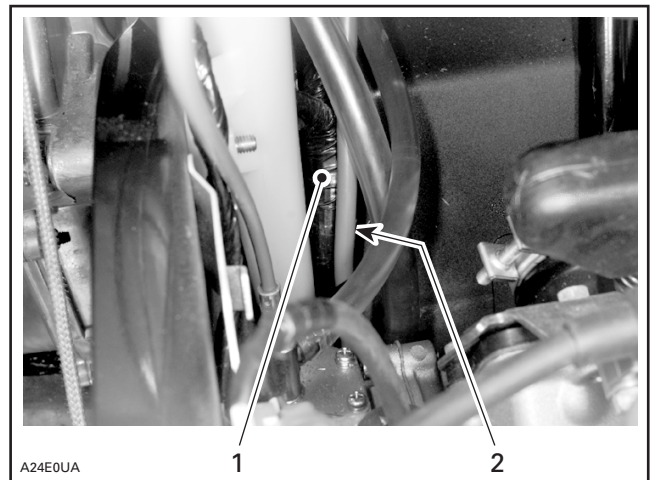

### ALONGSIDE HARNESS

1. Wiring harness
2. Battery positive cable

Make sure cables are pushed secured into corners and that locking ties are used where needed to protect cables from heat or vibration sources and sharp edges.

Install BLACK battery ground cable **no. 21** with star washer **no. 22** to rewind starter housing. Secure with existing rewind starter housing screw and lock washer.

**NOTE:** Connect BLACK ground cable in specified order: star washer first then BLACK ground cable and original lock washer and tighten with original screw.

Continue RED positive cable routing to starter solenoid alongside inner frame then left, alongside torsion bar.

Slide protector cap **no. 17** on the RED positive battery cable **no. 18**. Install RED cable, flat washer M8 **no. 24** onto solenoid inner threaded contact and secure with M8 nut **no. 23**. Cover terminal with protector cap previously inserted.

On one end of short positive cable **no. 16**, insert protector cap **no. 19** and on starter end of same cable insert protector cap **no. 17**. Slide cable terminal onto solenoid outer threaded contact then flat washer M8 **no. 24** and again secure with M8 nut **no. 23**. Cover contact with protector cap.

Refer to following illustration for solenoid/starter cable connections.

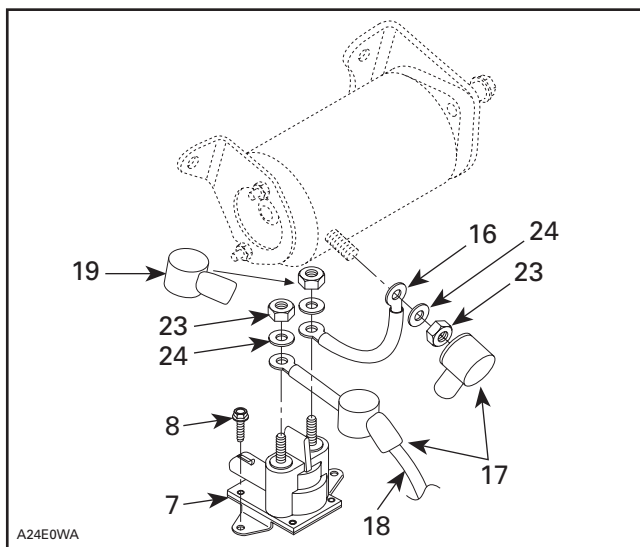

Using long locking tie **no. 32** secure RED positive cable to torsion bar.

## ◆ WARNING

Ensure all terminals are properly crimped on wires/cables and that all connector housings are properly fastened. Keep wires away from any rotating, moving, heating, vibrating parts and sharp edges. Use proper fastening devices as required.

## Electric Starter

### ▼ CAUTION

Apply Loctite 271 (red) on all fastener threads of starter supports.

Through opening on PTO side, start by depositing starter on floor pan.

Install starter support PTO side **no. 3** onto engine using socket screws M8 x 20 **no. 4** and lock washers **no. 5**. Tighten firmly.

Lift up and install electric starter **no. 9** on support, bottom bolts first and secure it using M8 x 25 socket screws **no. 6** and lock washers M8 **no. 5**.

Install flat washers M6 **no. 11** over nuts of starter through bolts.

Install starter support MAG side **no. 10** onto starter and secure with M5 flanged elastic nuts **no. 12**.

Secure support to engine with M8 x 20 socket screw **no. 4**, flat washer **no. 13** and lock washer **no. 5**.

Connect other end of short positive cable from solenoid onto starter contact, insert flat washer **no. 24** and secure at specified torque with M8 nut **no. 23**. Cover contact with previously inserted protector cap.

## Battery

On battery seat, remove and discard clips retaining oil line and small wiring harness.

Install rear battery steel strip **no. 28** in hole provided and let small wiring harness run behind it.

Install rubber strip **no. 26** and battery **no. 27** in their location.

Install front battery steel strip **no. 29**, making sure oil line and RED positive cable pass through indentation at its bottom.

Secure both steel strips with flanged elastic nut **no. 30**.

Insert protector cap **no. 20** on RED positive battery cable and connect same cable with red fuse holder wire (from ignition switch) to battery and cover post with protector cap. Connect BLACK ground cable.

## ◆ WARNING

Always connect battery cables exactly in the specified order. Connect RED positive cable first, then BLACK negative ground cable.

## Finalizing Assembly

Refer to the appropriate Ski-Doo *Shop Manual* for proper reinstallation procedure.

Reinstall drive pulley.

Check pulley alignment.

### **WARNING**

Drive pulley alignment must always be checked whenever pulleys have been removed, replaced or disassembled.

Reinstall remaining removed parts.

**NOTE:** Apply Dow Corning sealer no. 736 RTV on exhaust manifold ball joint.

Test electrical starting and ignition cut-out systems as per normal starting procedure for electric starter models.

## Decal

Clean decal area with soapy water or isopropyl alcohol using a soft clean cloth and dry thoroughly.

### **CAUTION**

Do not apply isopropyl alcohol on decal.

Remove backing from decal.

Apply decal **no. 33** below ignition switch on the left side of dash.

## 861 504 400

1.	515 175 217	Voltage Regulator	Régulateur de tension
2.	233 261 414	Flanged Elastic Nut M6 (2)	Écrou élastique à épaulement M6 (2)
3.	512 059 081	Starter Support PTO Side	Support de démarreur côté PDM
4.	205 082 044	Socket Screw M8 x 20 (3)	Vis à tête creuse M8 x 20 (3)
5.	234 181 401	Lock Washer M8 (5)	Rondelle-frein M8 (5)
6.	205 082 544	Socket Screw M8 x 25 (2)	Vis à tête creuse M8 x 25 (2)
7.	278 001 376	Starter Solenoid	Solénoïde de démarreur
8.	210 251 180	Self-Tapping Hexagonal Screw (2)	Vis autotaraudeuse à tête hexagonale (2)
9.	515 175 305	Starter	Démarreur
10.	512 056 600	Starter Support MAG Side	Support de démarreur côté MAG
11.	391 301 700	Flat Washer (2)	Rondelle plate (2)
12.	233 251 414	Flanged Elastic Nut M5 (2)	Écrou élastique à épaulement M5 (2)
13.	234 081 410	Flat Washer M8	Rondelle plate M8
14.	417 222 118	Ring Gear	Couronne de lancement
15.	732 601 246	Self-Tapping Screw (6)	Vis autotaraudeuse (6)
16.	515 175 101	Battery Positive Cable (short)	Câble positif de la batterie (court)
17.	570 064 200	Protector Cap (2)	Capuchon de protection (2)
18.	515 175 153	Battery Positive Cable	Câble positif de la batterie
19.	278 000 020	Protector Cap	Capuchon de protection
20.	570 151 000	Protector Cap	Capuchon de protection
21.	515 175 151	Battery Ground Cable	Câble de masse de la batterie
22.	394 001 900	Star Lock Washer (3)	Rondelle-frein en étoile (3)
23.	232 561 414	Elastic Hexagonal Nut (3)	Écrou élastique hexagonale (3)
24.	234 061 410	Flat Washer (3)	Rondelle plate (3)
25.	515 157 300	Fuse Holder	Porte-fusible
26.	570 070 300	Rubber Strip	Bande de caoutchouc
27.	410 301 200	Battery	Batterie
28.	515 175 114	Rear Steel Strip	Bande d'acier arrière
29.	515 175 116	Front Steel Strip	Bande d'acier avant
30.	233 251 414	Flanged Elastic Nut M5	Écrou élastique à épaulement M5
31.	414 115 200	Locking Tie (8)	Attache (8)
32.	748 001 001	Locking Tie	Attache
33.	418 001 302	Decal	Autocollant