

TABLE OF CONTENTS

| | |
|----------------------------------|----------------|
| STEERING SYSTEM | 08-02-1 |
| DISASSEMBLY AND ASSEMBLY | 08-02-2 |
| INSPECTION | 08-02-6 |
| STEERING ADJUSTMENT (SKIS) | 08-02-7 |
| LUBRICATION | 08-02-10 |

| | |
|--|----------------|
| SUSPENSION AND SKI SYSTEM | 08-03-1 |
| DISASSEMBLY..... | 08-03-2 |
| INSPECTION | 08-03-3 |
| INSTALLATION | 08-03-3 |

STEERING SYSTEM

CK3 Series

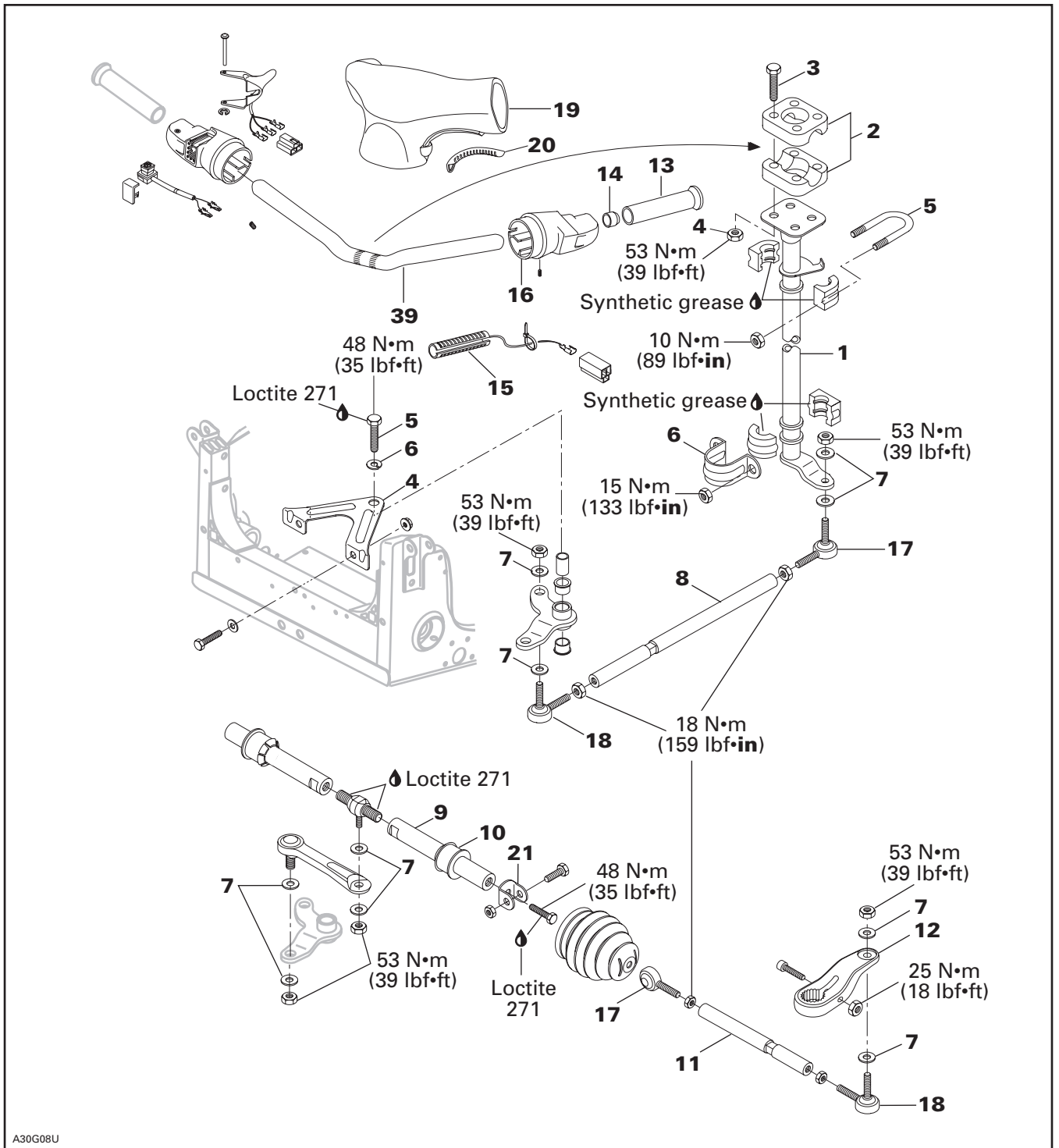

A30G08U

Section 08 STEERING/FRONT SUSPENSION

Subsection 02 (STEERING SYSTEM)

DISASSEMBLY AND ASSEMBLY

13, Grip

Grips must be carefully removed to prevent damaging the heating elements.

Heat grip with a heat gun.

Apply tape to handlebar near the grip to protect paint.

Inject compressed air into the handlebar and twist grip as pulling it out.

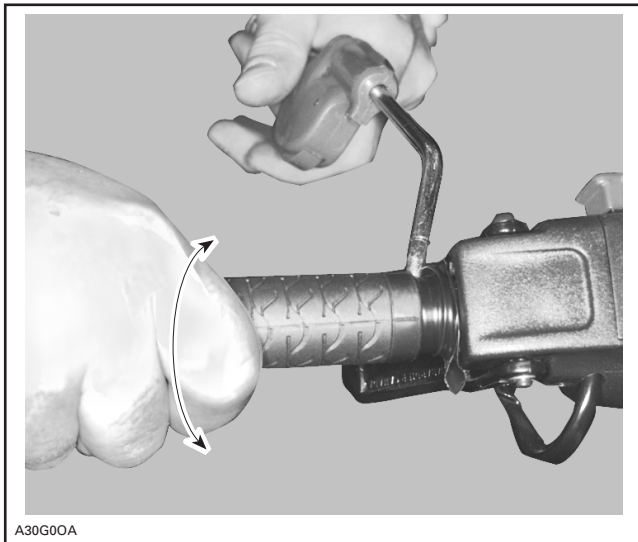

The grips might be unremovable as explained above, in this case, carefully proceed as follows to prevent damaging the heating elements.

Locate the element wires inside the handlebar; look through end of grip. Start cutting the grip exactly opposite the element wires and immediately peel it open to locate the gap in the heating element, as shown.

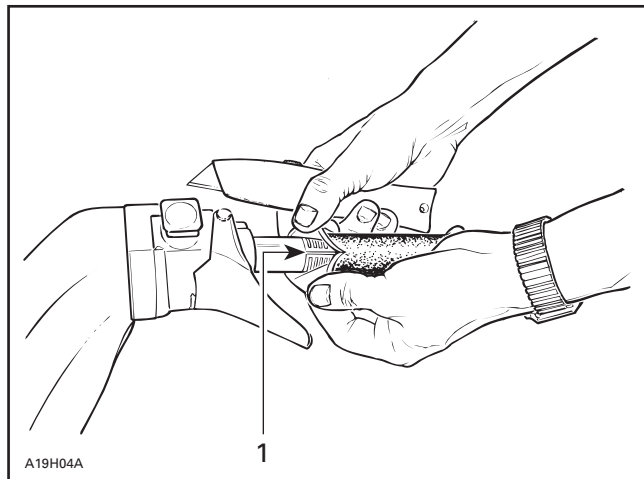

TYPICAL

1. Gap in the heating element opposite the wires

Continue cutting along the gap and remove the grip.

If required, slowly peel heating element **no. 15** from handlebar and remove it.

To install, stick the heating element to the handlebar making sure the wires do not interfere with operation of the accelerator or brake handle

Prior to install grips, position heating element protector **no. 14**.

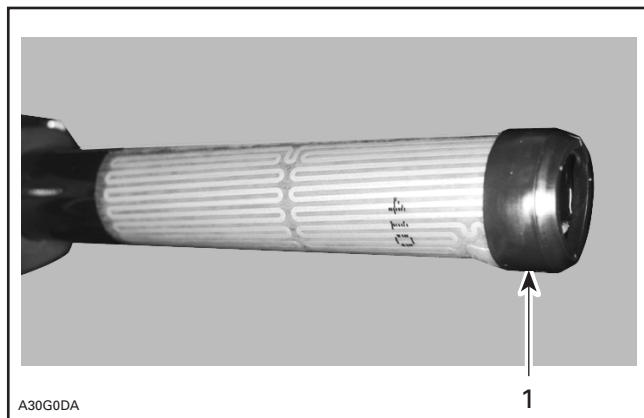

1. Heating element protector

Section 08 STEERING/FRONT SUSPENSION

Subsection 02 (STEERING SYSTEM)

◆ WARNING

Never use lubricants (e.g. soap, only grease, etc.) to install the handlebar grip, use a mix of soap and water. Mix 40 parts of water with one part of dish washing soap (recommended: Ultra Joy, Sunlight or Palmolive).

Heat the grip with a heater gun or a spot light to ease installation. Insert new grip with compressed air.



1, Steering Column

Remove steering pad, remove master cylinder from handlebar and put it aside. Remove circlip retaining throttle cable to throttle housing. Unplug all connector housings of handlebar switches. Remove handlebar ass'y.



HANDLEBAR ASS'Y

Cut locking tie retaining brake line and throttle cable to steering column.

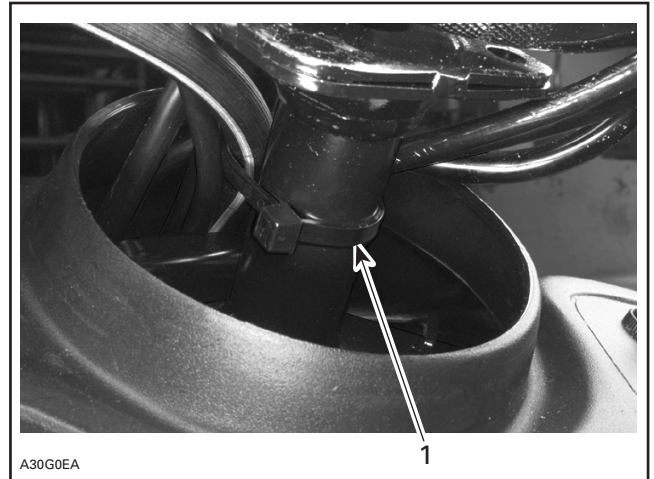

1. Cut this locking tie

Remove the air intake silencer then center and magneto side carburetors.

Unbolt console at center and sides.

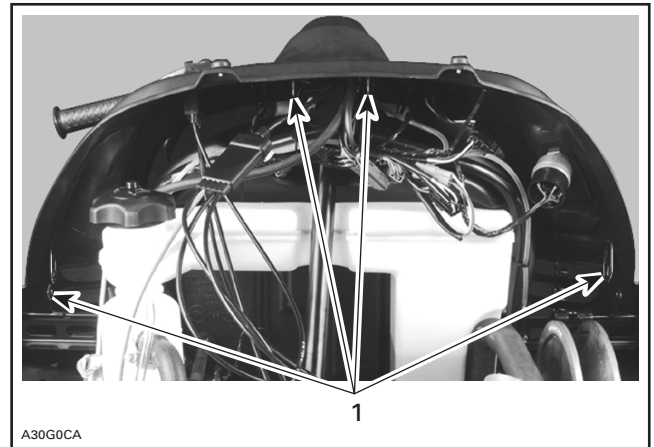

1. Unbolt console

Detach the short tie rod (under the engine) from the steering column. Note that a hardened flat washer **no. 7** goes on each side of steering column lever.

Section 08 STEERING/FRONT SUSPENSION

Subsection 02 (STEERING SYSTEM)

Remove U-clamp no. 6.

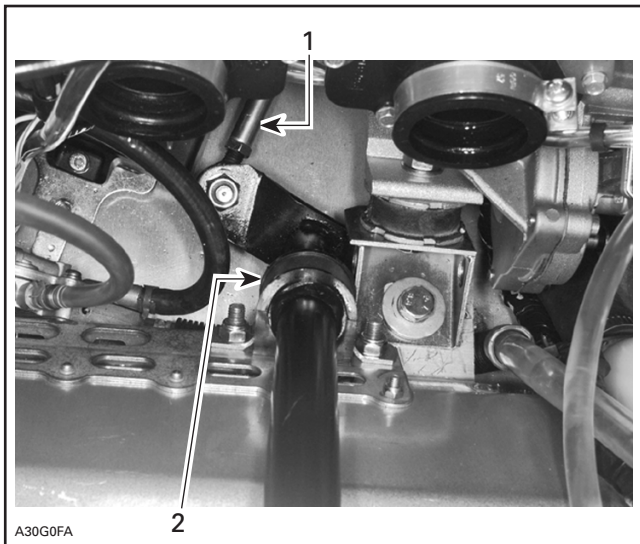

1. Short tie rod
2. U-clamp

Remove U-bolt no. 5 from steering support then, pull steering column from top.

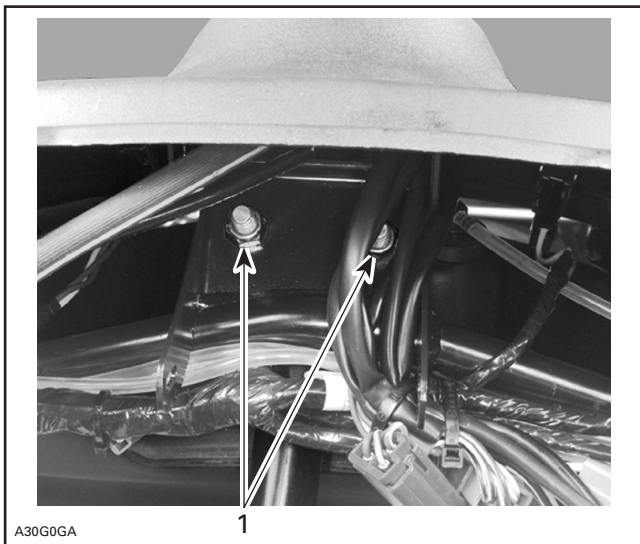

1. U-bolt nuts

17, Steering Arm

To maintain correct steering geometry for reassembling, scribe mark the steering arm and ski leg before disassembly.

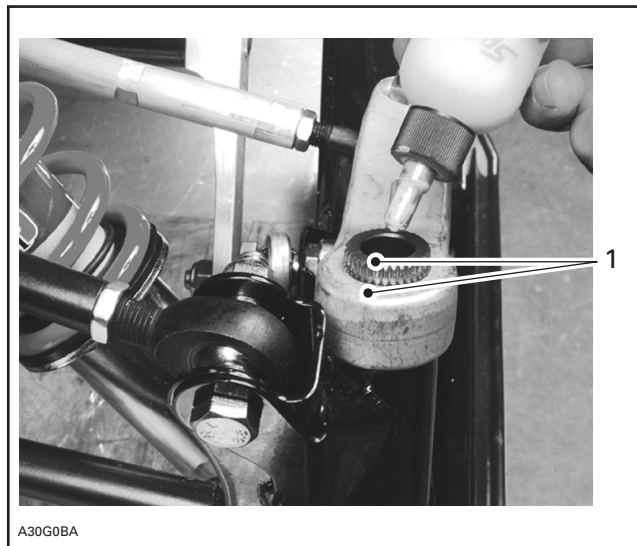

1. Marks

10, Bushing

Unscrew sliding rod no. 9.

Detach rubber boot from frame. Pull out sliding rod.

Working from engine compartment, drive out bushing no. 10.

Install a new bushing proceeding from front suspension pit.

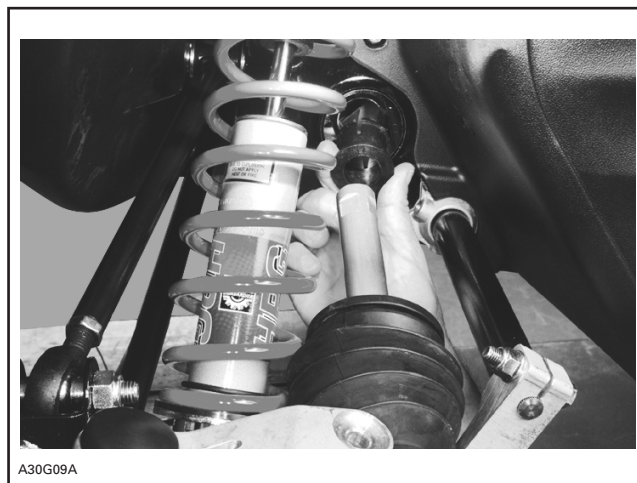

BUSHING INSTALLATION

Section 08 STEERING/FRONT SUSPENSION

Subsection 02 (STEERING SYSTEM)

17,18, Ball Joint (left hand and right hand threads)

The maximum external threaded length not engaged in the tie rod must not exceed the value L in the following thread length chart:

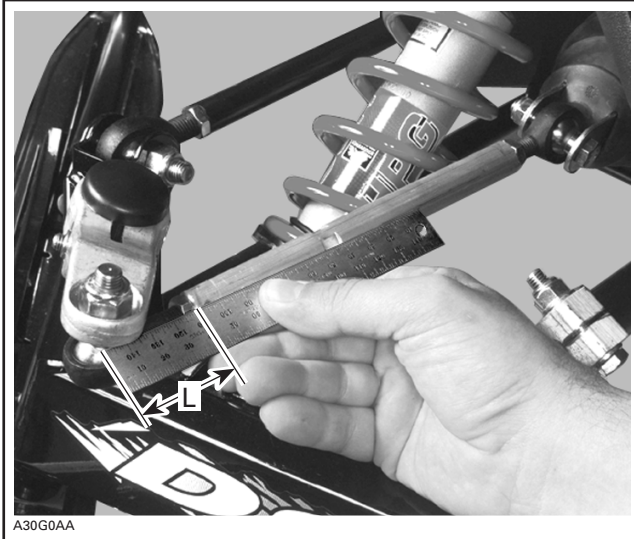

A30G0AA

TYPICAL

L: Threaded length not engaged

| BALL JOINT | L | |
|---|----|-----------|
| | mm | (in) |
| Outer ball joint of tie rods | 46 | (1-13/16) |
| Both ball joints of short tie rod (linking steering column to pivot arm) and inner ball joint of tie rods | 34 | (1-11/32) |

The ball joint should be restrained when tightening the tie rod end lock nut. Align it so the tie rod end is parallel to the steering arm when assembled on the vehicle, refer to the following illustration.

For proper torque specifications refer to the specific exploded view for the vehicle being serviced.

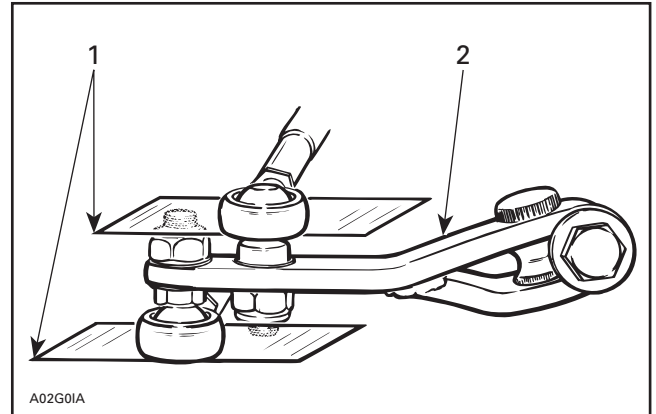

A02G0IA

TYPICAL

1. Parallel with steering arm
2. Steering arm

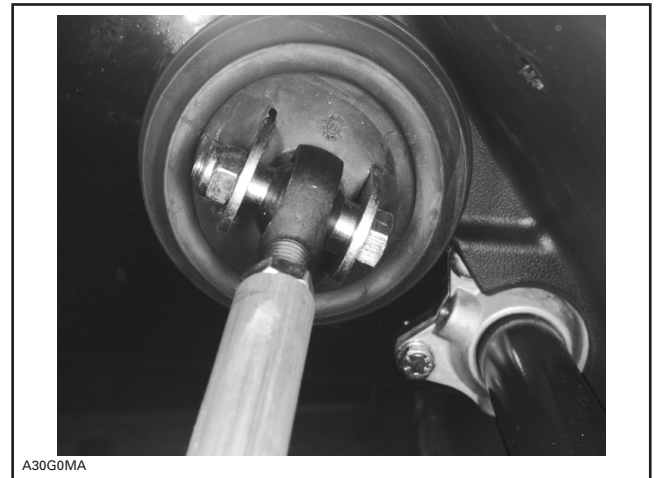

A30G0MA

TIE ROD BALL JOINT PARALLEL TO BRACKET BEFORE TIGHTENING

◆ WARNING

The cut off section of the ball joint must run parallel with the steering arm. When tightening lock nuts, restrain ball joint with appropriate size wrench. Ensure not too many threads are kept outside of the tie rod according to the thread length chart.

Section 08 STEERING/FRONT SUSPENSION

Subsection 02 (STEERING SYSTEM)

7, Hardened Washer

Install a hardened washer on each side of the arm.

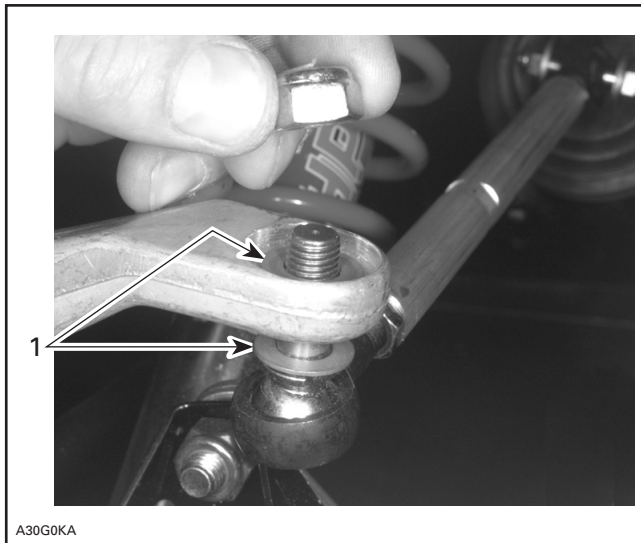

1. Hardened washers

12, Steering Arm

The steering arm angles should be equal on both sides when skis are parallel with vehicle.

Steering arm axis must run parallel to ski.

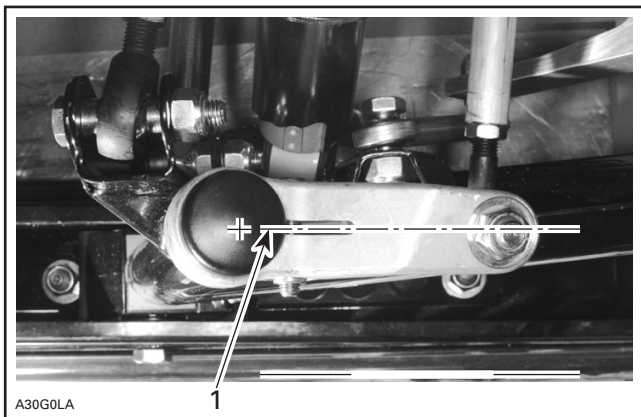

1. Parallel

Tighten the steering arm pinch bolt and nut to the torque specified in the exploded view.

INSPECTION

Check skis and runner shoes for wear, replace as necessary. Refer to FRONT SUSPENSION 08-03.

12, Steering Arm

Make sure steering arm and ski leg splines interlock.

◆ WARNING

Any parts having worn splines have to be replaced with new ones.

Check the general condition of the steering system components for wear. Replace if necessary.

15, Heating Grip Element

Refer to TESTING PROCEDURE 06-06.

17,18, Ball Joint (left hand and right hand threads)

Inspect ball joint ends for wear or looseness, if excessive, replace them.

ADJUSTABLE HANDLEBAR

Loosen all 4 nuts no. 4 retaining steering clamps no. 2.

Adjust the steering handlebar to the desired position.

Lock the handlebar in place by tightening the 4 nuts as specified in the illustrations.

▼ CAUTION

Tighten the nuts equally in a criss-cross sequence and ensure there is an equal gap on each side of the clamps.

Section 08 STEERING/FRONT SUSPENSION

Subsection 02 (STEERING SYSTEM)

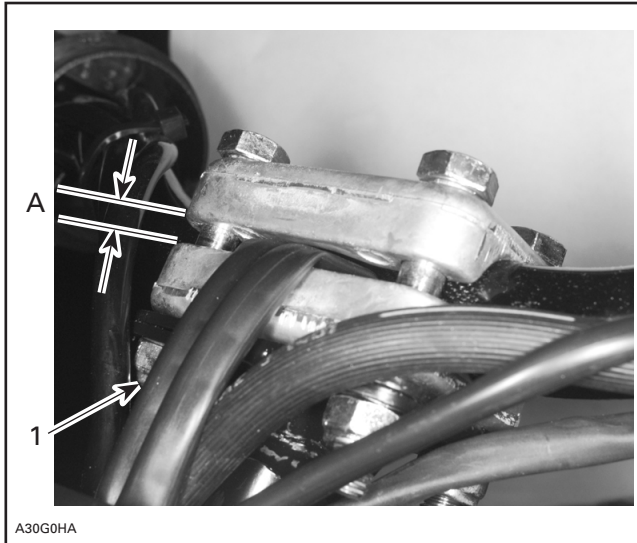

TYPICAL

1. Torque to 23 N•m (17 lbf•ft)
- A. Equal gap all around

◆ WARNING

Avoid contact between the brake handle and the windshield by NOT adjusting the handlebar too high.

◆ WARNING

Make sure that the steering pad and all controls are properly fixed to their normal location on the handlebar.

19,20, Steering Pad and Rubber Attachment

▼ CAUTION

Prior to installation, perform handlebar adjustment.

Properly fit the steering pad to the handlebar. Assemble using the 2 rubber attachments.

◆ WARNING

Make sure that the steering pad and all controls are properly fixed to their normal location on the handlebar.

STEERING ADJUSTMENT (SKIS)

Definitions

TOE-OUT:

A difference measured between the front edge of the skis "A" and rear edge "B" as viewed from the top. It is adjustable. For all CK3 models, toe-out is measured at 220 mm (8-21/32 in) from ski pivot bolt axis.

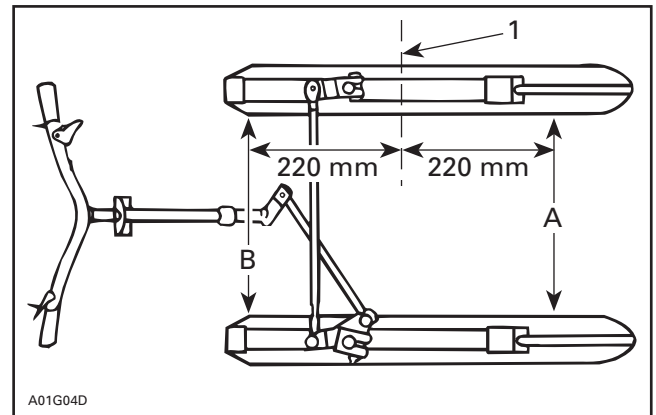

TYPICAL

1. Ski pivot bolt axis

CAMBER:

A specific inward or outward tilt angle of ski leg compared to a vertical line when viewing the vehicle from front.

Adjustments

Adjustments should be performed following this sequence:

- Pivot arm centering.
- Set camber angle.
- Check for a horizontal handlebar.
- Set toe-out.

PIVOT ARM CENTERING

◆ WARNING

Do not attempt to adjust straight ahead ski position by turning the ball joint on tie rod **no. 8**.

Section 08 STEERING/FRONT SUSPENSION

Subsection 02 (STEERING SYSTEM)

8,17,18,21, Tie Rod, Ball Joint and Bracket

Remove steering pad.

Turn handlebar all the way to the right. Check that the right side bracket no. 21 is against the bushing no. 10.

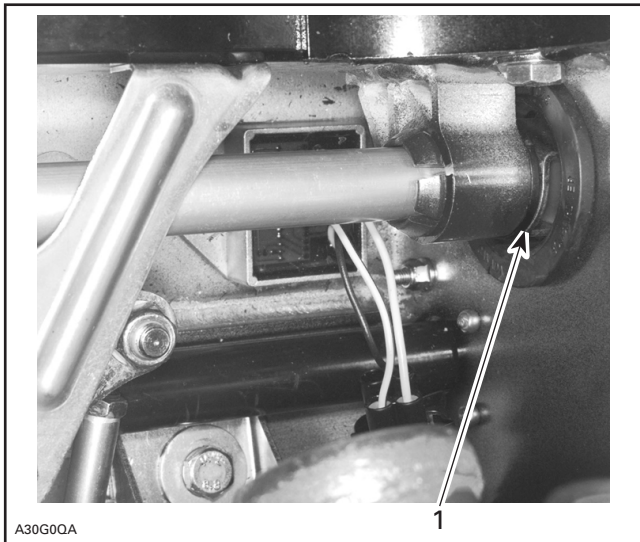

1. Bracket against the bushing

Keeping the handlebar in that position, check that the stopper on the steering column is almost touching the plate.

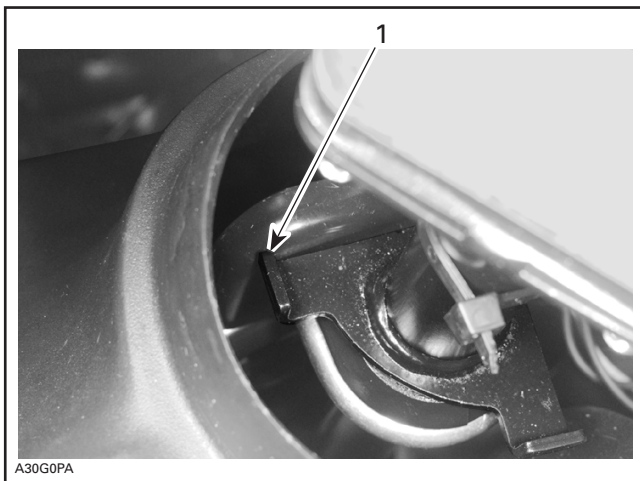

1. Stopper almost touching the plate

Loosen the jam nuts on tie rod no. 8 (LH threads on steering column end) and turn tie rod accordingly. Align and retighten the jam nuts to 18 N•m (159 lbf•in).

◆ WARNING

Never lengthen this tie rod so that threaded portion of ball joint exceeds 34 mm (1-11/32 in).

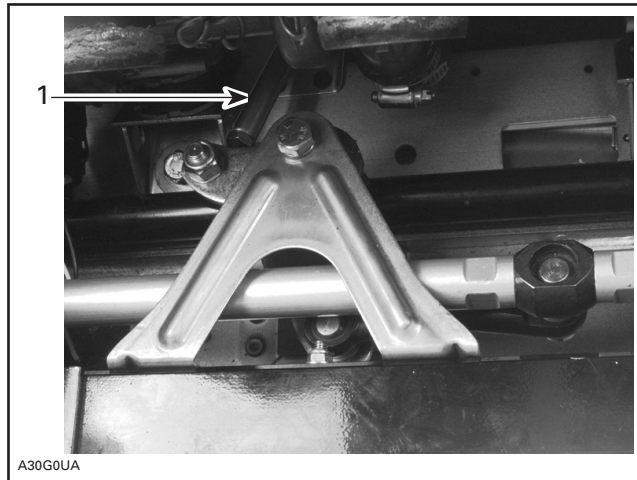

1. Tie rod no. 8

CAMBER

NOTE: Identical adjustments are required on both sides of the vehicle.

- Make sure the vehicle is leveled by placing an angle finder under the main frame member as shown on the following illustration.
- Vehicle skis must be off the ground.

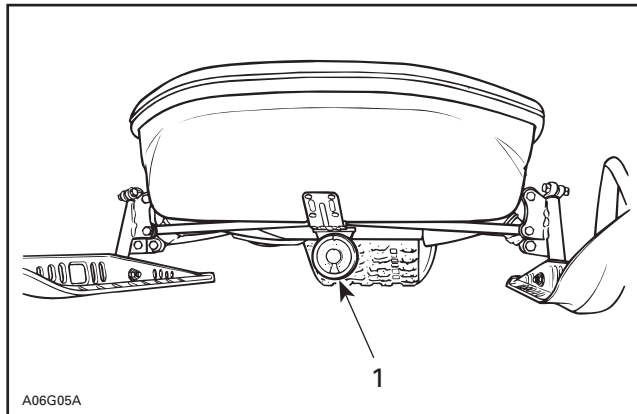

TYPICAL

1. Angle finder

Section 08 STEERING/FRONT SUSPENSION

Subsection 02 (STEERING SYSTEM)

Using special tool (P/N 529 021 600) mounted to the ski leg, position the angle finder on the tool as shown in the following illustration. An alternate location for the angle finder if the special tool is not available is the outside of the ski leg housing.

▼ CAUTION

Angle finder must sit square against swing arm. Positioning angle finder against weld bead or decal may result in false reading.

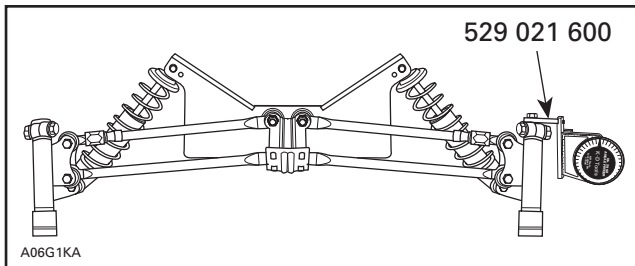

TYPICAL — CAMBER ADJUSTMENT SET-UP

Adjusting

- Loosen lock nut on both upper control arms.
- Unbolt both upper control arms at ski leg housing. Turn tie rod half turn at a time to obtain the specified value when skis are not touching ground. Bolt upper control arms.

| MODEL | CAMBER ± 0.5° |
|---|------------------|
| GT 700/SE Mach Z LT/Z LT R | - 4.5 |
| Formula III 600/700/800 Mach 1/1 R/Z/Z R | - 2.5 |

NOTE: Because of a negative camber, skis will lean toward center of vehicle.

Tighten lock nut on both upper control arms.

HANDLEBAR AND SKI TOE-OUT

Check that handlebar is horizontal when skis are in straight ahead position by measuring from the extremities of the grips to the rearmost edge of the tunnel, as shown.

NOTE: The reference point must be the same relative to each side.

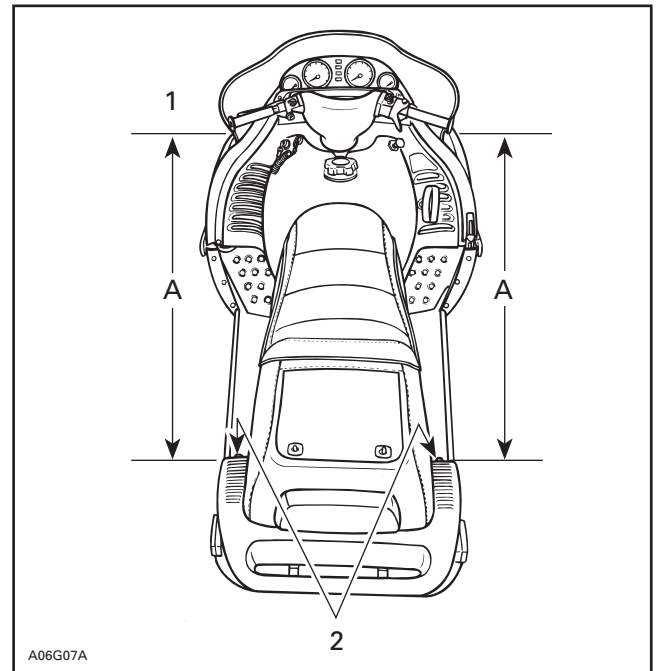

TYPICAL

1. Equal distance A on each side
2. Same reference point

Adjustment is performed by adjusting length of left and right tie rods no. 11.

◆ WARNING

Do not attempt to adjust skis straight ahead position by turning ball joint on tie rod no. 8.

Procedure:

- Loosen jam nuts of both tie rods no. 11.
- Turn the tie rod on one side to shorten its length.
- Lengthen the other one by turning it exactly the same amount, so that toe-out is not changed.

◆ WARNING

Never lengthen tie rod so that threaded portion of inner ball joint exceeds 34 mm (1-11/32 in) and 46 mm (1-13/16 in) for outer ball joint.

- Close front of skis manually to take all slack from steering mechanism.

NOTE: A rubber cord must be hooked in front of skis to keep them closed.

Section 08 STEERING/FRONT SUSPENSION

Subsection 02 (STEERING SYSTEM)

Toe-out must be as specified when skis are in a straight-ahead position and the front of vehicle is lifted off the ground.

| MODEL | TOTAL TOE-OUT + 3 mm (+ 1/8 in) - 0 mm (- 0 in) |
|---|---|
| GT 700/SE Mach Z LT/Z LT R | 12 (1/2) |
| Formula III 600/700/800 Mach 1/1 R/Z/Z R | 16 (5/8) |

NOTE: To make sure skis are in a straight-ahead position, place a straight edge against pre-adjusted track and measure the distance between front and rear of skis and straight edge.

To reduce tolerance when measuring, set one ski to proper toe-out (half the total toe-out) then measure from that ski to the opposite ski.

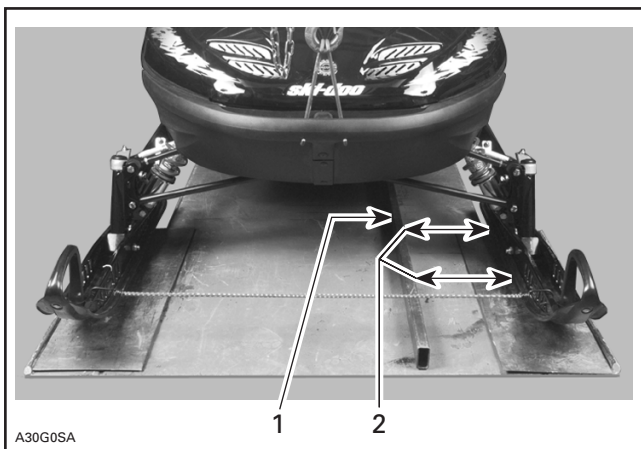

1. Straight edge
2. Measure at 220 mm (8-21/32 in) from ski pivot axis

LUBRICATION

◆ WARNING

Do not lubricate throttle cable or housing.

26, Grease Fittings

Only use synthetic grease (P/N 413 711 500).

The following symbols will be used to show what type of lubricant should be used at the suitable locations.

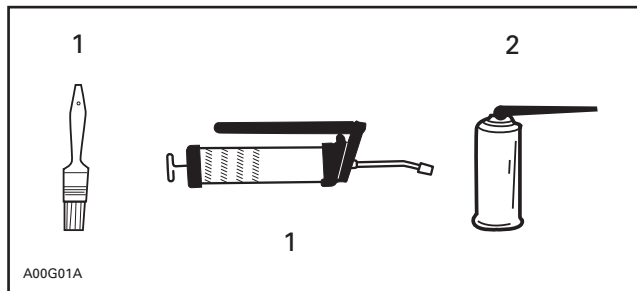

1. Synthetic grease (P/N 413 711 500)
2. BOMBARDIER LUBE (P/N 293 600 016)

Lubricate:

- Steering column bushings.
- Short tie rod ends.
- Ball stud lever.
- Upper arm ball joint.
- Grease ski legs and ski pivots.
- Stabilizer ball joints.

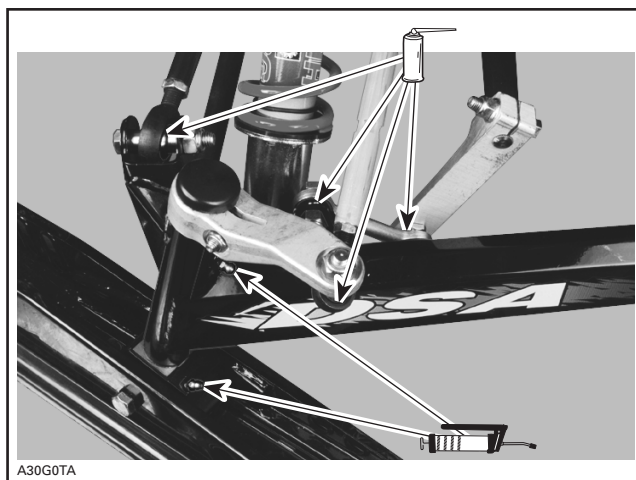
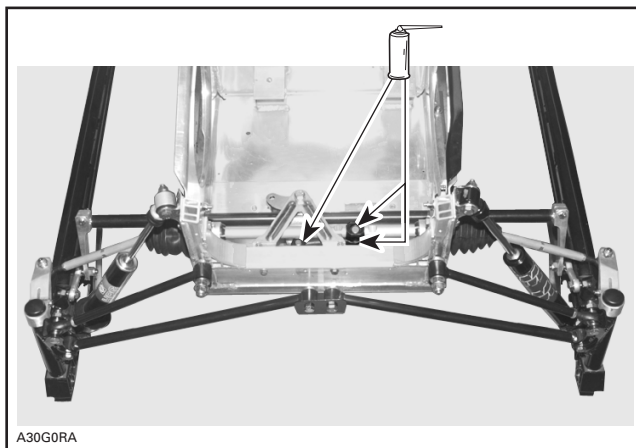

SUSPENSION AND SKI SYSTEM

CK3 Series

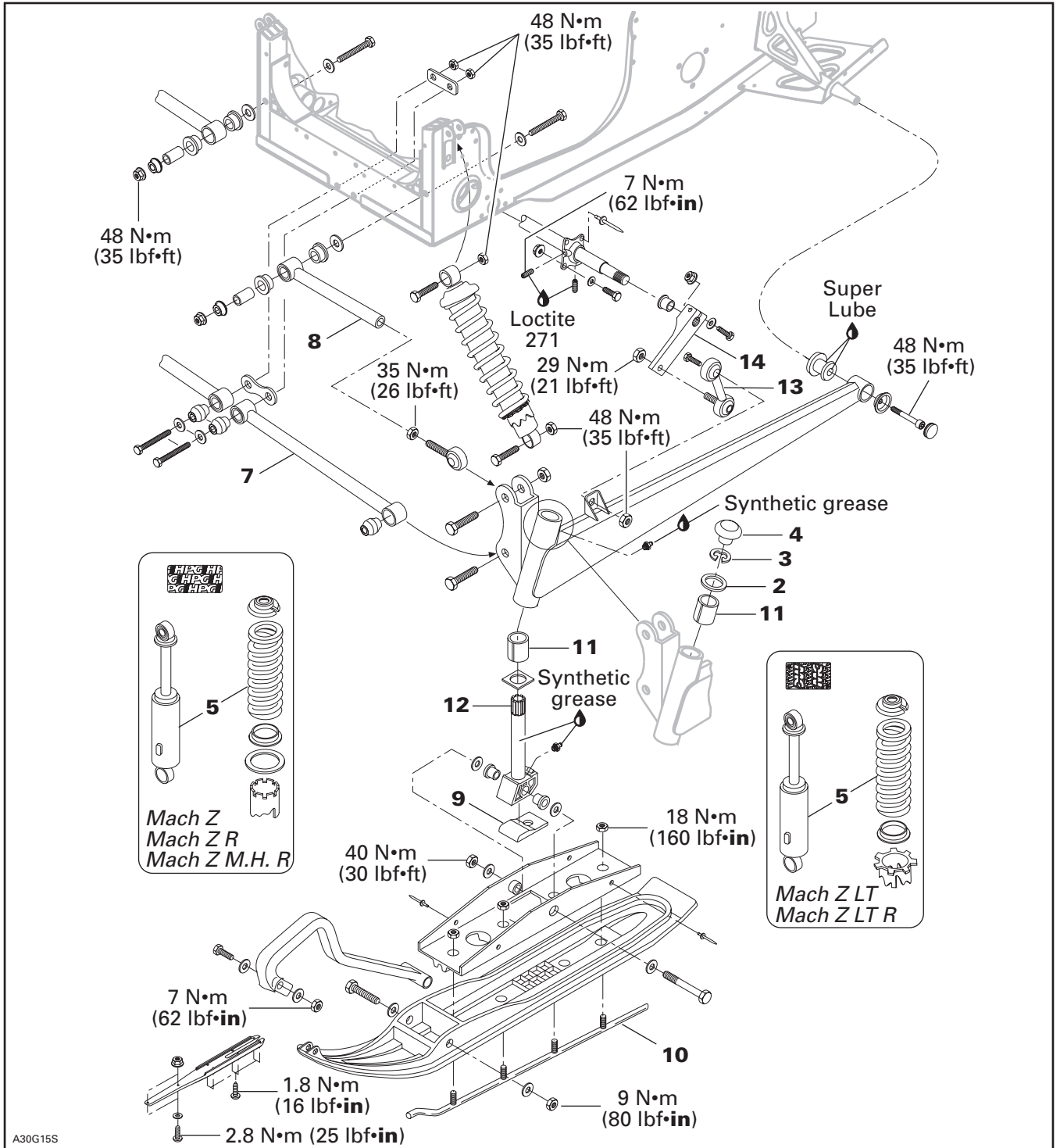

Section 08 STEERING/FRONT SUSPENSION

Subsection 03 (SUSPENSION AND SKI SYSTEM)

DISASSEMBLY

5, Shock

Lift front of vehicle and support it off the ground. Reduce spring preload by turning adjusting ring accordingly with the adjustment wrench in vehicle tool box.

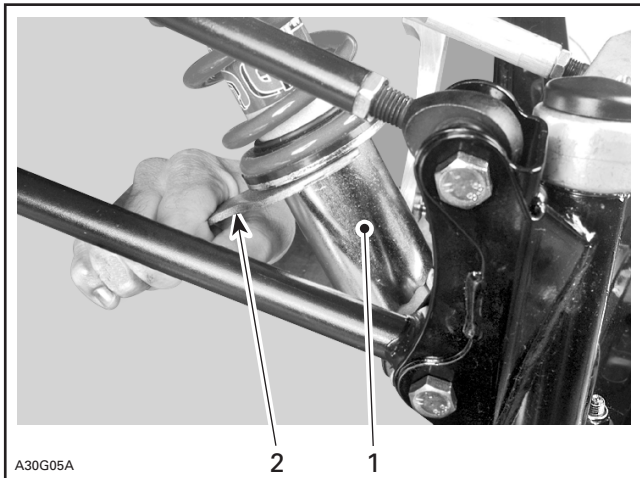

TYPICAL

1. Shock cam
2. Adjustment wrench

Remove lower bolt then upper bolt of shock.

For shock spring disassembly use shock spring remover (P/N 529 027 100) in a vise. Mount shock in it and turn shock so that spring coils matched spring compressor.

Close and lock the bar. Adjust the handle horizontal position by changing the position of the clevis pin.

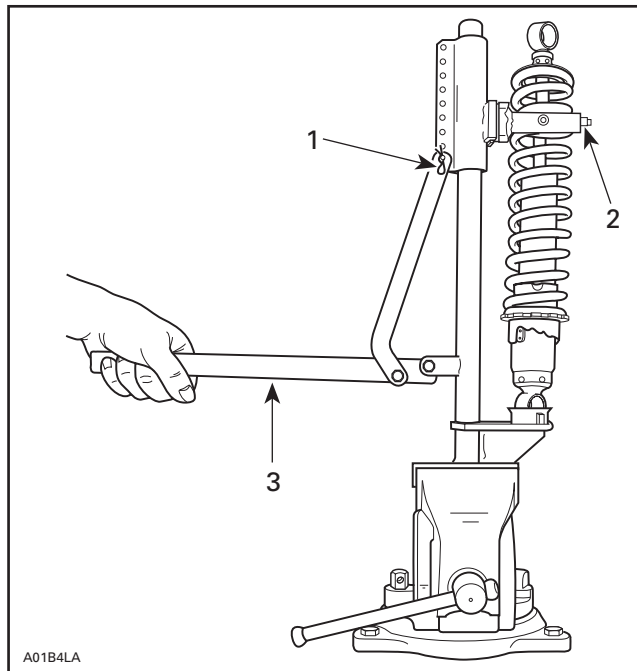

1. Clevis pin
2. Bar
3. Handle horizontal

Push down on the handle until it locks. Remove spring stopper then release handle.

1, Swing Arm

Lift front of vehicle and support it off the ground.

Remove cap **no. 4**, circlip **no. 3** then loosen steering arm bolt and pull up steering arm. Note shim **no. 2** positions. Ski leg may fall off from swing arm.

Remove bushings **no. 11**.

Section 08 STEERING/FRONT SUSPENSION

Subsection 03 (SUSPENSION AND SKI SYSTEM)

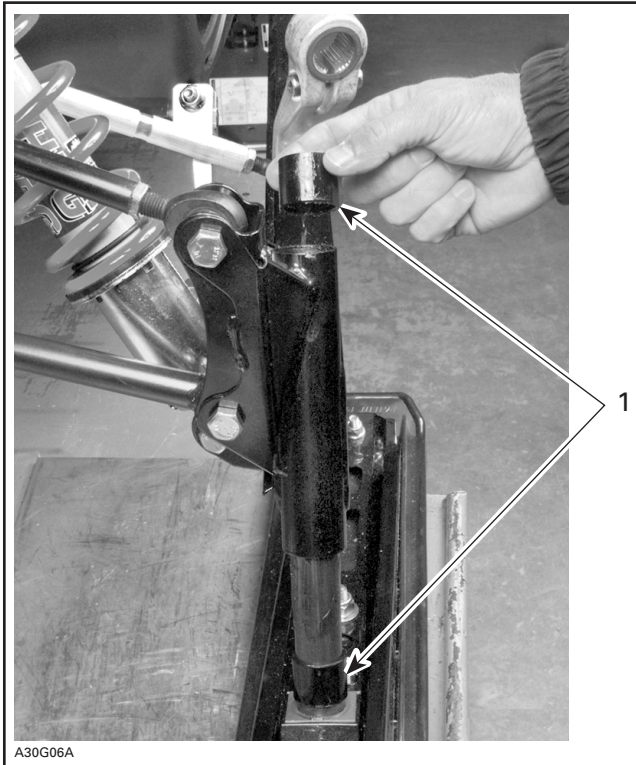

1. Bushings no. 11

Unbolt lower end of shock from swing arm.
Unbolt radius rod.

14, Lever

Unbolt tie rod no. 13 ball joint from swing arm.
Unbolt rear of swing arm from frame.
Pull swing arm off the vehicle.

INSPECTION

Check all rubber cushions for crack and wear. Replace as required.

Check straightness of ski leg no. 12 and make sure that splines are properly interlocking with steering arm. Replace as required.

Check for straightness of swing arm. Replace as required.

Check for clogged grease fittings. Clean or replace as required.

Check skis and runners no. 10 for wear, replace as necessary.

Check condition of ski stopper no. 9. Replace it when deteriorated.

To check condition of shock, refer to SC-10 SUSPENSION 07-02 then look for **Shock Absorber Inspection**.

INSTALLATION

For assembly, reverse the disassembly procedure. However, pay attention to the following.

Apply synthetic grease (P/N 413 711 500) to ski leg components.

Tighten nuts and screws to proper torque as mentioned in exploded view.

7,8, Upper and Lower Half Arms

Position half arms and tie rods horizontally before tightening nuts.

8, Adjustable Half Arm

Refer to STEERING SYSTEM 08-02 for proper camber adjustment using these half arms.

13,14, Tie Rod and Lever

Install levers pointing downward on both sides at same angle, see following photo.

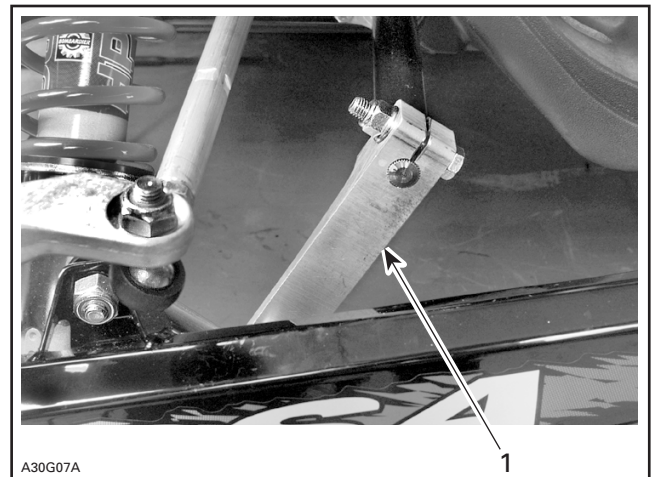

1. Lever pointing downward