

ski-doo®



SHOP MANUAL 1999

Volume 3

GRAND TOURING 700/SE
FORMULA III 600/700/800
MACH 1/1 R/Z/Z R/Z LT/Z LT R

484 200 005

1999 ***Shop Manual***

VOLUME 3

GRAND TOURING 700/SE

FORMULA III 600/700/800

MACH 1/1 R/Z/Z R/Z LT/Z LT R/Z M.H. R

BOMBARDIER
RECREATIONAL PRODUCTS





Legal deposit:

National Library of Quebec
1st trimester 1999
National Library of Canada 1999

All rights reserved. No parts of this manual may be reproduced in any form without the prior written permission of Bombardier Inc.

©Bombardier Inc. 1999

Technical Publications
Bombardier Inc.
Valcourt (Quebec) Canada

Printed in Canada

®*Registered trademarks of Bombardier Inc.

This document contains the trademarks of the following companies:

Kimtowels® is a trademark of Kimberly-Clark

Loctite® is a trademark of Loctite Corporation

Molykote® is a trademark of Dow Corning Corporation

Silastic® is a trademark of Dow Corning Corporation

Snap-on® is a trademark of Snap-on Tools Corporation

Versilube® is a trademark of General Electric Company

Supertanium™ is a trademark of Premier Industrial Corporation

TABLE OF CONTENTS

SECTION	SUBSECTION	PAGE
SAFETY NOTICE		III
WHAT'S NEW		IV
INTRODUCTION		V
01	SERVICE TOOLS AND SERVICE PRODUCTS	
	01 – Service tools.....	01-01-1
	02 – Service products.....	01-02-1
02	LUBRICATION AND MAINTENANCE	
	01 – Lubrication and maintenance chart	02-01-1
03	TROUBLESHOOTING	
	01 – Table of contents.....	03-01-1
	02 – Engine	03-02-1
	03 – Fuel and oil systems.....	03-03-1
	04 – Transmission and brake systems	03-04-1
	05 – Electrical system	03-05-1
	06 – Suspension and track	03-06-1
04	ENGINE	
	01 – Table of contents.....	04-01-1
	02 – 599, 699 and 809 engine types	04-02-1
	03 – Leak test and engine dimension measurement	04-03-1
	04 – CDI system.....	04-04-1
	05 – Oil injection system.....	04-05-1
	06 – Liquid cooling system.....	04-06-1
	07 – Rewind starter.....	04-07-1
	08 – Carburetor and fuel pump	04-08-1
	09 – Fuel tank and throttle cable	04-09-1
05	TRANSMISSION	
	01 – Table of contents.....	05-01-1
	02 – Drive belt	05-02-1
	03 – Drive pulley.....	05-03-1
	04 – Driven pulley.....	05-04-1
	05 – Pulley distance and alignment.....	05-05-1
	06 – Brake	05-06-1
	07 – Chaincase	05-07-1
	08 – Drive chain.....	05-08-1
06	ELECTRICAL	
	01 – Table of contents.....	06-01-1
	02 – Ignition timing.....	06-02-1
	03 – Spark plugs.....	06-03-1
	04 – Battery	06-04-1
	05 – Electric starter	06-05-1
	06 – Testing procedure	06-06-1
07	REAR SUSPENSION	
	01 – Table of contents.....	07-01-1
	02 – SC-10 suspension.....	07-02-1
	03 – Drive axle.....	07-03-1
	04 – Track.....	07-04-1

TABLE OF CONTENTS

SECTION	SUBSECTION	PAGE
08 STEERING/ FRONT SUSPENSION	01 – Table of contents	08-01-1
	02 – Steering system	08-02-1
	03 – Suspension and ski system	08-03-1
09 BODY/FRAME	01 – Table of contents	09-01-1
	02 – Body	09-02-1
	03 – Frame	09-03-1
10 TECHNICAL DATA	01 – SI metric information guide	10-01-1
	02 – Engines	10-02-1
	03 – Vehicles	10-03-1
	04 – Technical data legends	10-04-1
11 WIRING DIAGRAMS	01 – Wiring diagrams	11-01-1

SAFETY NOTICE

This manual has been prepared as a guide to correctly service and repair some 1999 Ski-Doo snowmobiles. See model list on next page.

This edition was primarily published to be used by snowmobile mechanics who are already familiar with all service procedures relating to Bombardier made snowmobiles.

Please note that the instructions will apply only if proper hand tools and special service tools are used.

This *Shop Manual* uses technical terms which may be slightly different from the ones used in the *Parts Catalog*.

It is understood that this manual may be translated into another language. In the event of any discrepancy, the English version shall prevail.

The content depicts parts and/or procedures applicable to the particular product at its time of manufacture. It does not include dealer modifications, whether authorized or not by Bombardier, after manufacturing the product.

In addition, the sole purpose of the illustrations throughout the manual, is to assist identification of the general configuration of the parts. They are not to be interpreted as technical drawings or exact replicas of the parts.

The use of Bombardier parts is most strongly recommended when considering replacement of any component. Dealer and/or distributor assistance should be sought in case of doubt.

The engines and the corresponding components identified in this document should not be utilized on product(s) other than those mentioned in this document.

Torque wrench tightening specifications must be strictly adhered to. Locking devices (ex.: locking tab, elastic stop nut, etc.) must be installed or replaced with new ones, where specified. If the efficiency of a locking device is impaired, it must be renewed.

This manual emphasizes particular information denoted by the wording and symbols:

 WARNING
--

Identifies an instruction which, if not followed, could cause serious personal injury including possibility of death.

 CAUTION
--

Denotes an instruction which, if not followed, could severely damage vehicle components.
--

NOTE: Indicates supplementary information needed to fully complete an instruction.

Although the mere reading of such information does not eliminate the hazard, your understanding of the information will promote its correct use. Always use common shop safety practice.

This information relates to the preparation and use of Bombardier snowmobiles and has been utilized safely and effectively by Bombardier Inc. However, Bombardier Inc. disclaims liability for all damages and/or injuries resulting from the improper use of the contents. We strongly recommend that any services be carried out and/or verified by a highly skilled professional mechanic. It is understood that certain modifications may render use of the vehicle illegal under existing federal, provincial and state regulations.

WHAT'S NEW

WHAT'S NEW

INTRODUCTION

- Loctite application procedure as published in *Service Bulletin 97-14*.

ELECTRICAL SYSTEM 03-05

- Troubleshooting of RER system.

599, 699 AND 809 ENGINE TYPES 04-02

- Procedure for lubrication of PTO outer bearing.

OIL INJECTION SYSTEM 04-05

- Procedure for leak test.

DRIVEN PULLEY 05-04

- Repair procedures for HPV27 driven pulley type.

IGNITION TIMING 06-02

- Ignition timing procedure.

TESTING PROCEDURE 06-06

- Testing values.

SC-10 SUSPENSION (ALL VERSIONS) 07-02

- Wear limit of slider shoe is now indicated by a line.

STEERING SYSTEM 08-02

- Ski alignment specifications.

INTRODUCTION

This *Shop Manual Volume 3* covers the following Bombardier made 1999 snowmobiles:

MODELS	MODEL NUMBER
FORMULA* III 600 (Canada).....	1396
FORMULA* III 600 (U.S.)	1397
FORMULA* III 600 (Europe)	1398
FORMULA* III 700 (Canada).....	1399
FORMULA* III 700 (U.S.)	1400
FORMULA* III 800 (Canada).....	1401
FORMULA* III 800 (U.S.)	1402
MACH* 1 (Canada).....	1422
MACH* 1 (U.S.)	1437
MACH* 1 (Europe)	1423
MACH* 1 R (Canada)	1442
MACH* 1 R (U.S.).....	1443
MACH* 1 R (Europe).....	1444
MACH* Z (Canada).....	1418
MACH* Z (U.S.)	1435
MACH* Z (Europe)	1419
MACH* Z R (Canada)	1439
MACH* Z R (U.S.).....	1440
MACH* Z R (Europe).....	1441
MACH* Z M.H. R (U.S.).....	1462
MACH* Z LT (Canada).....	1420
MACH* Z LT (U.S.)	1436
MACH* Z LT R (Canada)	1445
MACH* Z LT R (U.S.).....	1446
MACH* Z LT R (Europe).....	1447
GRAND TOURING 700 (Can. and U.S.)	1373
GRAND TOURING 700 (Europe)	1374
GRAND TOURING SE (Can. and U.S.)	1375
GRAND TOURING SE (Europe)	1376

*Trademarks of Bombardier Inc.

INTRODUCTION

Grand Touring 700/SE
Formula III 600/700/800
Mach 1/1 R/Z/Z R/Z M.H. R/Z LT/Z LT R

These are CK3 Series models.

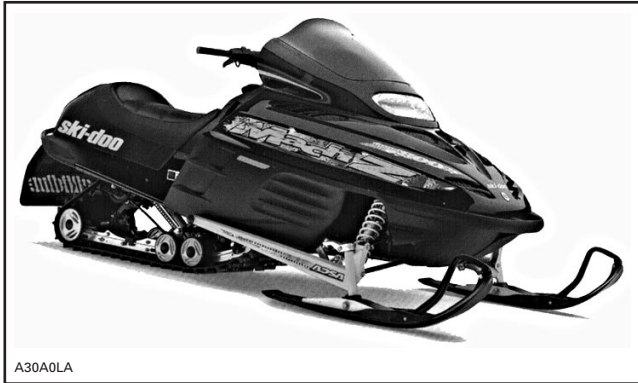

TYPICAL — CK3 SERIES

VEHICLE SERIAL NUMBER

Vehicle Serial Number Location

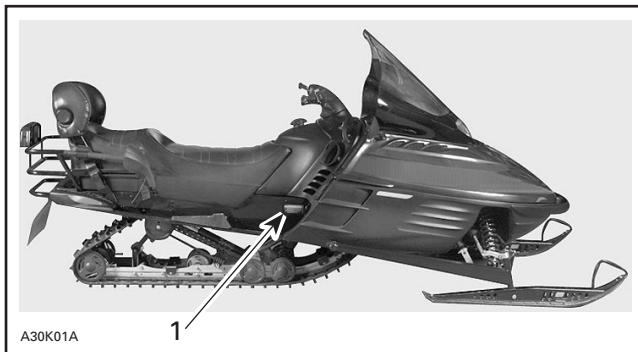

TYPICAL

1. Vehicle serial number

Serial Number Meaning

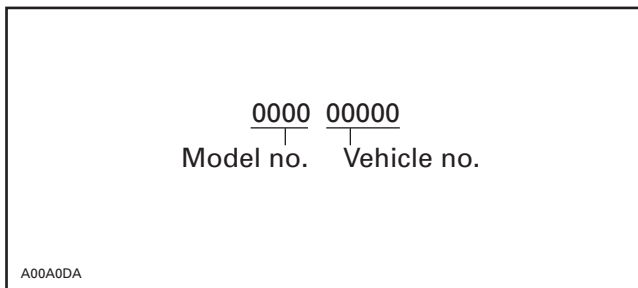

ENGINE SERIAL NUMBER

Engine Serial Number Location



1. Engine serial number

ARRANGEMENT OF THE MANUAL

The manual is divided into 11 major sections:

- 01 SERVICE TOOLS AND SERVICE PRODUCTS
- 02 LUBRICATION AND MAINTENANCE
- 03 TROUBLESHOOTING
- 04 ENGINE
- 05 TRANSMISSION
- 06 ELECTRICAL
- 07 REAR SUSPENSION
- 08 STEERING/FRONT SUSPENSION
- 09 BODY/FRAME
- 10 TECHNICAL DATA
- 11 WIRING DIAGRAMS

Each section is divided in various subsections, and again, each subsection has one or more division.

LIST OF ABBREVIATIONS USED IN THIS MANUAL

A	ampere
amp	ampere
A•h	ampere-hour
AC	alternate current
ACM	acceleration and control modulator
ADSA	advanced direct shock action
BDC	bottom dead center
BTDC	before top dead center
°C	degree Celsius
CDI	capacitor discharge ignition
CTR	center
cm	centimeter
cm ²	square centimeter
cm ³	cubic centimeter
DC	direct current
DESS	digitally encoded security system
DPM	digital performance management
°F	degree Fahrenheit
FC	fan cooled
fl. oz	fluid ounce
ft	foot
GRD	ground
H.A.C.	high altitude compensator
hal.	halogen
HI	high
imp. oz	imperial ounce
in	inch
in ²	square inch
in ³	cubic inch
k	kilo (thousand)
kg	kilogram
km/h	kilometer per hour
kPa	Kilopascal
L	liter
lb	pound
lbf	pound (force)
lbf/in ²	pound per square inch

LH	left hand
LO	low
LT	long track
m	meter
MAG	magneto
Max.	maximum
Min.	minimum
mL	milliliter
mm	millimeter
MPEM	multi-purpose electronic module
MPH	mile per hour
N	newton
N.A.	not applicable
no.	number
00.0	continuity
0.L	open line (open circuit)
O.D.	outside diameter
OPT	optional
oz	ounce
P/N	part number
PSI	pound per square inch
PTO	power take off
R	rectangular
RH	right hand
RAVE	rotax adjustable variable exhaust
RPM	revolution per minute
RMS	root mean square
RRIM	reinforced reaction injection molding
Sp. Gr.	specific gravity
ST	semi-trapeze
TDC	top dead center
TRA	total range adjustable
U.S. oz	ounce (United States)
V	volt
Vac	volt (alternative current)

INTRODUCTION

This *Shop Manual* uses technical terms which may be slightly different from the ones in the parts catalog.

TYPICAL PAGE

Page heading indicates section and subsection detailed.

Subsection title indicates beginning of the subsection.

Italic subtitle above exploded view indicate pertaining models.

Drop represents a liquid product to be applied to a surface. In this case Loctite 271 to screw threads.

Bold face number indicates special procedure concerning this part.

Dotted box contains parts of a particular model in this case the short track models only.

Page numbering system:
 07: REAR SUSPENSION section
 01: SUSPENSION SC-10 SPORT,
 TOURING AND MOUNTAIN subsection
 1: First page of this subsection

Section 07 REAR SUSPENSION
 Subsection 01 (SUSPENSION SC-10 SPORT, TOURING AND MOUNTAIN)

**SUSPENSION SC-10 SPORT,
 TOURING AND MOUNTAIN**

Grand Touring 500/580, Formula 500/583 and Summit 500

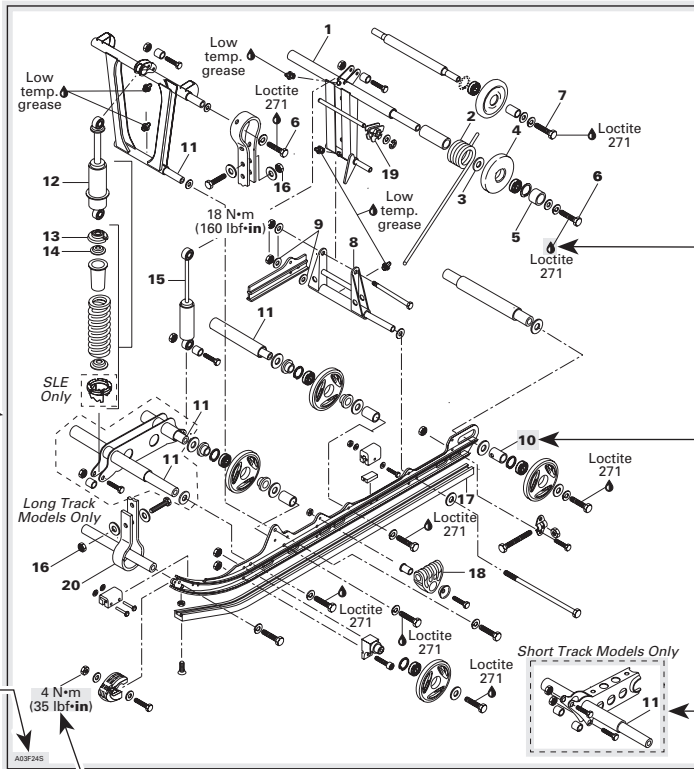

Exploded view assists you in identifying parts and related positions.

Illustration number for publishing process.

Tightening torque nearby fastener. In this case, nut must be torqued to 4 N·m or 35 lbf·in.

▼ CAUTION
 Pay attention to torque specifications. Some of these are in lbf·in instead of lbf·ft. Use appropriate torque wrench.

TYPICAL PAGE

Section 05 TRANSMISSION
Subsection 03 (DRIVEN PULLEY)

Turn puller handle and sliding half at once to extract the bushing.

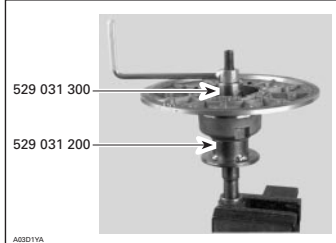

IMPORTANT: Large bushing retaining screws and washers must be removed before small bushing installation.
Coat bushing outside diameter with Loctite 609 (P/N 413 703 100).
Install bushing as following photo.

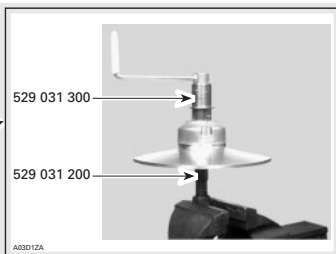

ASSEMBLY
Came Slider Shoe

When replacing slider shoes no. 4, always install a new set (3 shoes) to maintain equal pressure on the cam.
Assemble driven pulley components by reversing the disassembly procedure.

Cam

Coat cam **no. 18** interior with anti-seize lubricant.

INSTALLATION

Countershaft

CAUTION

Always apply anti-seize lubricant (P/N 413 701 000) on the countershaft before final pulley installation.

F-Series and S-Series Only

Should installation procedure be required, refer to BRAKE 05-05 then look for Brake Disc and Countershaft Bearing Adjustment.
Reinstall the pulley on the countershaft by reversing the removal procedure.

All Models

Check end play of driven pulley on countershaft by pushing pulley towards outer housing so that the inner shims (P/N 504 108 200) contact it. Measure end play at the mounting screw end between shim(s) and pulley. See illustration.

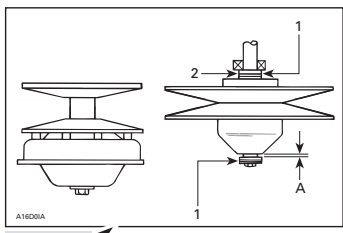

Torque retaining screw no. 13 to 25 N•m (18 lbf•ft).

ADJUSTMENT

Refer to PULLEY DISTANCE AND ALIGNMENT 05-04 to adjust pulley distance. Adjust drive belt height between pulley halves to obtain specified belt deflection.

05-03-5

A01A27S

Title indicates main procedure to be carried-out.

Italic bold face type setting indicates a particular procedure concerning a model.

Italic bold face setting in this case indicates that particular procedure for F and S-Series is finished, so from this point, all models are concerned.

"TYPICAL" caption indicates a general view which does not represent full detail.
"TOP VIEW" caption helps you in understanding illustration.

Call-outs for above illustration.

Reference to look up a certain section and subsection. In this case it concerns pulleys adjustment.

Illustration always follows text to which it pertains.

Subtitle indicates a particular procedure for the named part.

Bold face number following part name refers to exploded view at beginning of subsection.

INTRODUCTION

GENERAL INFORMATION

The information and component/system descriptions contained in this manual are correct at time of publication. Bombardier Inc. however, maintains a policy of continuous improvement of its products without imposing upon itself any obligation to install them on products previously manufactured.

Due to late changes, it may have some differences between the manufactured product and the description and/or specifications in this document.

Bombardier Inc. reserves the right at any time to discontinue or change specifications, designs, features, models or equipment without incurring obligation.

USEFUL PUBLICATIONS

Refer to *Parts Catalogs* to order the right parts.

PARTS CATALOG	
MODELS	P/N
FORMULA III 600 FORMULA III 700 FORMULA III 800	480 400 009
MACH 1 MACH 1 R	480 400 011
MACH Z MACH Z R MACH Z LT MACH Z LT R MACH Z M.H. R	480 400 012
GRAND TOURING 700 GRAND TOURING SE	480 400 013

Use *Specification Booklet* to find rapidly the right specs.

1995-1999 SPECIFICATION BOOKLET (P/N 484 300 002).

ILLUSTRATIONS AND PROCEDURES

Illustrations and photos show the typical construction of the different assemblies and, in all cases, may not reproduce the full detail or exact shape of the parts shown. However, they represent parts which have the same or a similar function.

▼ CAUTION

Most components of those vehicles are built with parts dimensioned in the metric system. Most fasteners are metric and must not be replaced by customary fasteners or vice versa. Mismatched or incorrect fasteners could cause damage to the vehicle or possible personal injury.

As many of the procedures in this manual are interrelated, we suggest, that before undertaking any task, you read and thoroughly understand the entire section or subsection in which the procedure is contained.

A number of procedures throughout the book require the use of special tools. Before commencing any procedure, be sure that you have on hand all the tools required, or approved equivalents.

The use of RIGHT and LEFT indications in the text, always refers to driving position (when sitting on vehicle).



TYPICAL

1. Left
2. Right

LOCTITE APPLICATION PROCEDURE

The following describes the most common application procedures when working with Loctite products.

NOTE: Always use proper strength Loctite product as recommended in this *Shop Manual*.

THREADLOCKER

Uncovered Holes (bolts and nuts)

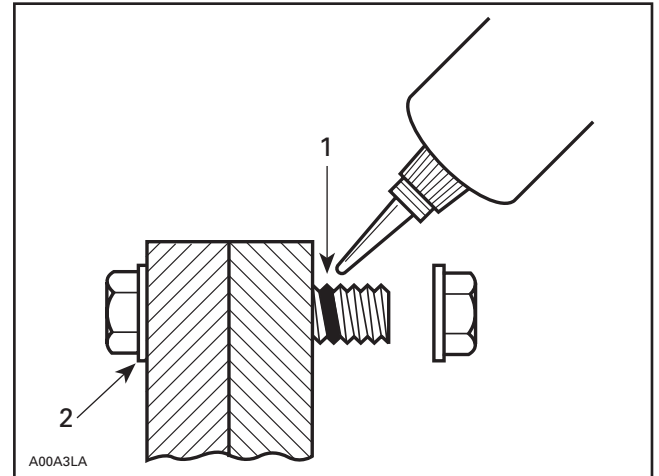

1. Apply here
2. Do not apply

1. Clean threads (bolt and nut) with solvent.
2. Apply Loctite Primer N (P/N 293 800 041) on threads and allow to dry.
3. Choose proper strength Loctite threadlocker.
4. Fit bolt in the hole.
5. Apply a few drops of threadlocker at proposed tightened nut engagement area.
6. Position nut and tighten as required.

Blind Holes

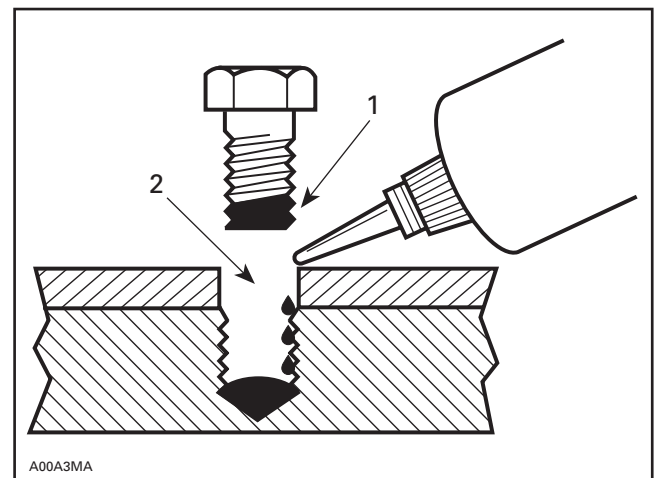

1. On threads
2. On threads and at the bottom of hole

INTRODUCTION

1. Clean threads (bolt and hole) with solvent.
2. Apply Loctite Primer N (P/N 293 800 041) on threads (bolt and nut) and allow to dry for 30 seconds.
3. Choose proper strength Loctite threadlocker.
4. Apply several drops along the threaded hole and at the bottom of the hole.
5. Apply several drops on bolt threads.
6. Tighten as required.

Blind Holes

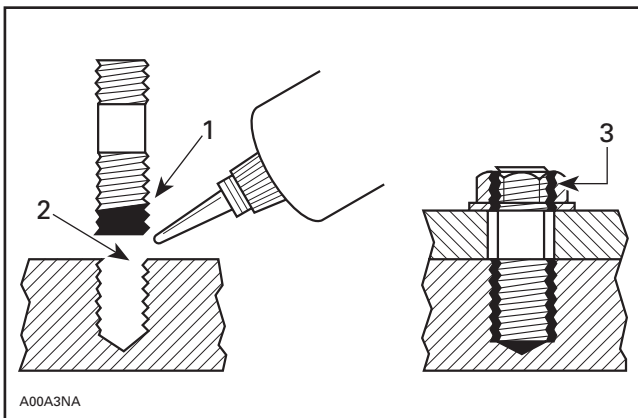

1. On threads
2. On threads and in the hole
3. Onto nut threads

1. Clean threads (bolt and hole) with solvent.
2. Apply Loctite Primer N (P/N 293 800 041) on threads and allow to dry.
3. Put several drops of proper strength Loctite threadlocker on female threads and in hole.
4. Apply several drops of proper strength Loctite on stud threads.
5. Install stud.
6. Install cover, etc.
7. Apply drops of proper strength Loctite on uncovered threads.
8. Tighten nuts as required.

Preassembled Parts

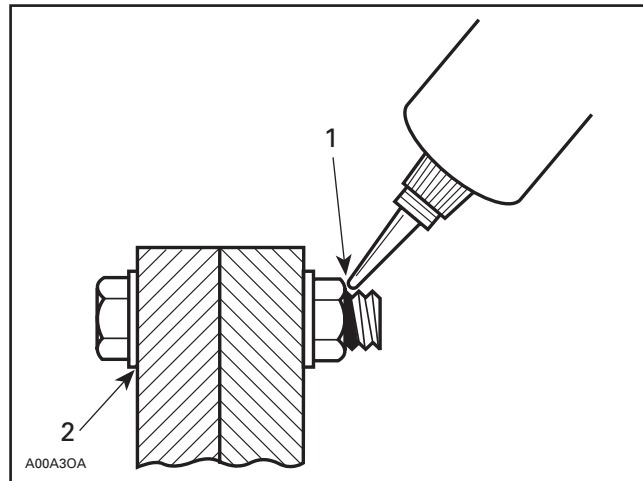

1. Apply here
2. Do not apply

1. Clean bolts and nuts with solvent.
2. Assemble components.
3. Tighten nuts.
4. Apply drops of proper strength Loctite on bolt/nut contact surfaces.
5. Avoid touching metal with tip of flask.

NOTE: For preventive maintenance on existing equipment, retighten nuts and apply proper strength Loctite on bolt/nut contact surfaces.

Adjusting Screw

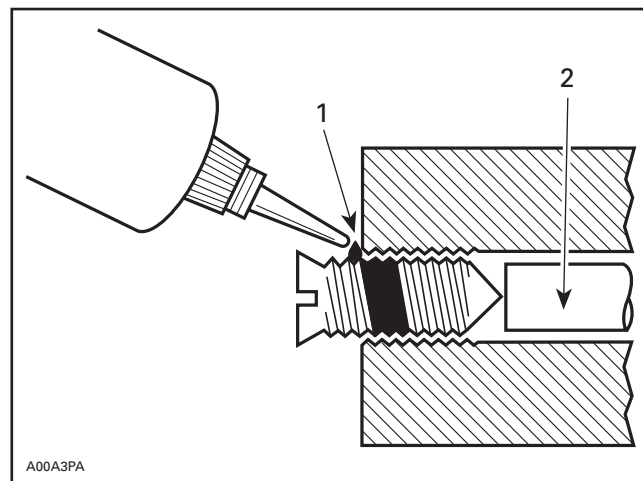

1. Apply here
2. Plunger

1. Adjust screw to proper setting.
2. Apply drops of proper strength Loctite threadlocker on screw/body contact surfaces.

3. Avoid touching metal with tip of flask.

NOTE: If it is difficult to readjust, heat screw with a soldering iron (232°C (450°F)).

STRIPPED THREAD REPAIR

Stripped Threads

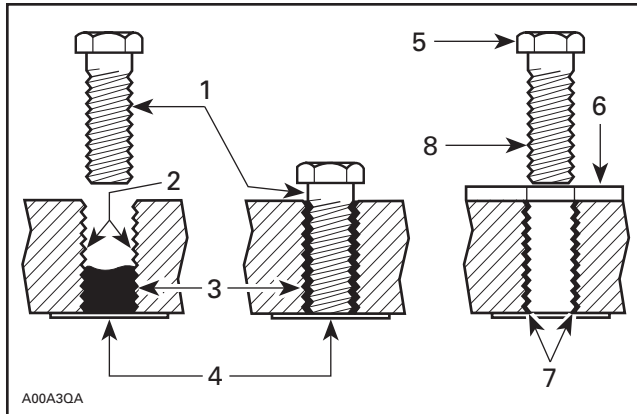

1. Release agent
2. Stripped threads
3. Form-A-Thread
4. Tape
5. Cleaned bolt
6. Plate
7. New threads
8. Threadlocker

Standard Thread Repair

1. Follow instructions on Loctite FORM-A-THREAD (P/N 413 708 600) package.
2. If a plate is used to align bolt:
 - a. Apply release agent on mating surfaces.
 - b. Put waxed paper or similar film on the surfaces.
3. Twist bolt when inserting it to improve thread conformation.

NOTE: NOT intended for engine stud repairs.

Repair of Small Holes/Fine Threads

Option 1: Enlarge damaged hole, then follow **Standard Thread Repair** procedure.

Option 2: Apply FORM-A-THREAD on the screw and insert in damaged hole.

Permanent Stud Installation (light duty)

1. Use a stud or thread on desired length.
2. DO NOT apply release agent on stud.
3. Do a **Standard Thread Repair**.
4. Allow to cure for 30 minutes.
5. Assemble.

GASKET COMPOUND

All Parts

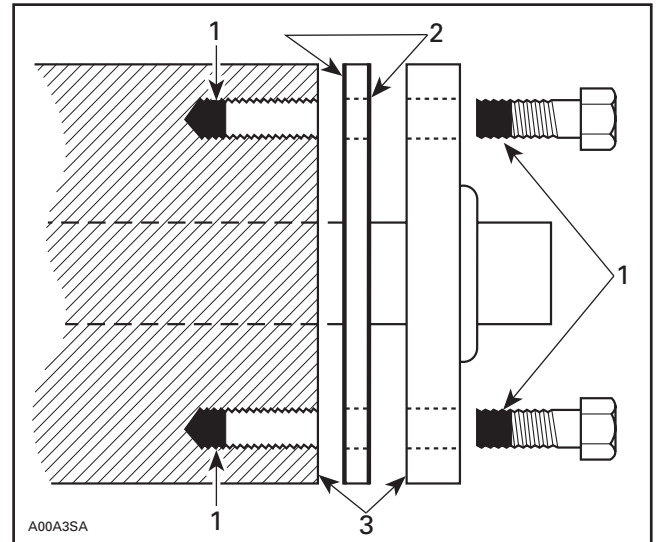

1. Proper strength Loctite
2. Loctite Primer N (P/N 413 708 100) and Gasket Eliminator 515 (P/N 413 702 700) on both sides of gasket
3. Loctite Primer N only

1. Remove old gasket and other contaminants with Loctite Chisel remover (P/N 413 708 500). Use a mechanical mean if necessary.

NOTE: Avoid grinding.

2. Clean both mating surfaces with solvent.
3. Spray Loctite Primer N on both mating surfaces and on both sides of gasket. Allow to dry 1 or 2 minutes.
4. Apply GASKET ELIMINATOR 515 (P/N 413 702 700) on both sides of gasket, using a clean applicator.
5. Place gasket on mating surfaces and assemble immediately.

NOTE: If the cover is bolted to blind holes (above), apply proper strength Loctite in the hole and on threads. Tighten.

If holes are sunken, apply proper strength Loctite on bolt threads.

6. Tighten as usual.

INTRODUCTION

MOUNTING ON SHAFT

Mounting with a Press

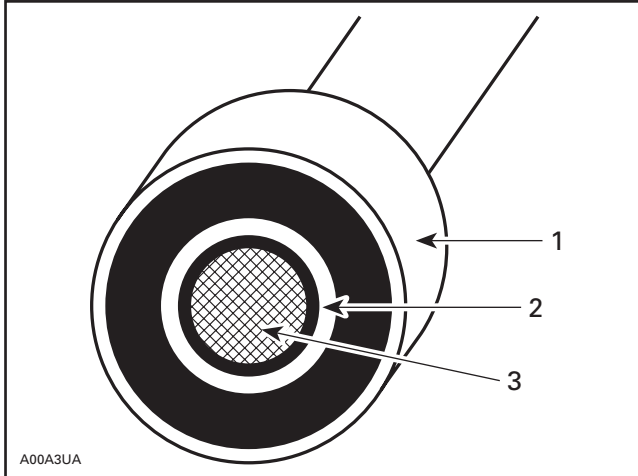

1. Bearing
2. Proper strength Loctite
3. Shaft

Standard

1. Clean shaft external part and element internal part.
2. Apply a strip of proper strength Loctite on shaft circumference at insert or engagement point.

NOTE: Retaining compound is always forced out when applied on shaft.

3. DO NOT use anti-seize Loctite or any similar product.
4. No curing period is required.

Mounting in Tandem

1. Apply retaining compound on internal element bore.
2. Continue to assemble as shown above.

CASE-IN COMPONENTS

Metallic Gaskets

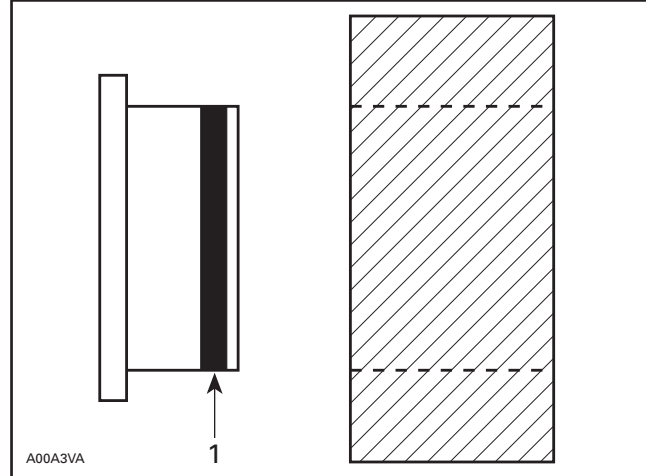

1. Proper strength Loctite

1. Clean inner housing diameter and outer gasket diameter.
2. Spray housing and gasket with Loctite Primer N (P/N 293 800 041).
3. Apply a strip of proper strength Loctite on leading edge of outer metallic gasket diameter.

NOTE: Any Loctite product can be used here. A low strength liquid is recommended as normal strength and gap are required.

4. Install according to standard procedure.
5. Wipe off surplus.
6. Allow it to cure for 30 minutes.

NOTE: Normally used on worn-out housings to prevent leaking or sliding.

It is generally not necessary to remove gasket compound applied on outer gasket diameter.

TIGHTENING TORQUES

Tighten fasteners to torque mentioned in exploded views and text. When they are not specified refer to following table. Bold face size (e.g. **M4**) indicates nominal value (mean value).

N•m	FASTENER SIZE (8.8 GRADE)	Lbf•in
2	M4	18
3	M4	27
4	M5	35
8	M6	71
9	M6	80
10	M6	89
11	M6	97
12	M6	106

N•m	FASTENER SIZE (8.8 GRADE)	Lbf•ft
21	M8	15
22	M8	16
23	M8	17
24	M8	18
25	M8	18
43	M10	32
44	M10	32
45	M10	33
46	M10	34
47	M10	35
48	M10	35
49	M10	36
50	M10	37
51	M10	38
52	M10	38
53	M10	39
76	M12	56
77	M12	57
78	M12	58
79	M12	58
80	M12	59
81	M12	60
82	M12	60
83	M12	61
84	M12	62
121	M14	89
122	M14	90
123	M14	91

N•m	FASTENER SIZE (8.8 GRADE)	Lbf•ft
124	M14	91
125	M14	92
126	M14	93
127	M14	94
128	M14	94
129	M14	95
130	M14	96
131	M14	97
132	M14	97
133	M14	98
134	M14	99
135	M14	100
136	M14	100
137	M14	101
138	M14	102
139	M14	103
140	M14	103
141	M14	104
142	M14	105
143	M14	105
144	M14	106
145	M14	107
146	M14	108
147	M14	108
148	M14	109
149	M14	110
150	M14	111

We would be pleased if you could communicate to Bombardier any suggestions you may have concerning our publications.

Bombardier SERVICE PUBLICATIONS REPORT

Publication title and year _____ Page _____

Machine _____ Report of error Suggestion

Name _____

Address _____

City and State/Prov. _____ Date _____

Zip code/Postal code _____

Bombardier SERVICE PUBLICATIONS REPORT

Publication title and year _____ Page _____

Machine _____ Report of error Suggestion

Name _____

Address _____

City and State/Prov. _____ Date _____

Zip code/Postal code _____

Bombardier SERVICE PUBLICATIONS REPORT

Publication title and year _____ Page _____

Machine _____ Report of error Suggestion

Name _____

Address _____

City and State/Prov. _____ Date _____

Zip code/Postal code _____



AFFIX
PROPER
POSTAGE



BOMBARDIER
RECREATIONAL PRODUCTS

Technical Publications
After Sales Service
565 de la Montagne Street
Valcourt, Quebec, Canada J0E 2L0

AFFIX
PROPER
POSTAGE



BOMBARDIER
RECREATIONAL PRODUCTS

Technical Publications
After Sales Service
565 de la Montagne Street
Valcourt, Quebec, Canada J0E 2L0

AFFIX
PROPER
POSTAGE



BOMBARDIER
RECREATIONAL PRODUCTS

Technical Publications
After Sales Service
565 de la Montagne Street
Valcourt, Quebec, Canada J0E 2L0