

# WIRING DIAGRAMS

MODEL	WIRING DIAGRAM PAGE	HEADLIGHT (watt)	TAILLIGHT (watt)	ELECTRICAL SYSTEM OUTPUT (watt)
Skandic WT/SWT	Annex 1	60/55 hal.	8/27	240
Skandic WT LC	Annex 2	60/55 hal.	8/27	220
MX Z 440	Annex 3	60/55 hal.	8/27	240
Formula Z 500/583/670 MX Z 500 and Summit 500	Annex 4	60/55 hal.	8/27	220
Formula DLX 500/583/670	Annex 5	60/55 hal.	8/27	220
MX Z 670 HO and Summit X 670	Annex 6	60/55 hal.	8/27	220
Grand Touring 500/583	Annex 7	60/55 hal.	8/27	220

hal. = halogen

## WIRING DIAGRAM LEGEND

**◆ WARNING**

Ensure all terminals are properly crimped on the wires and all connector housings are properly fastened.

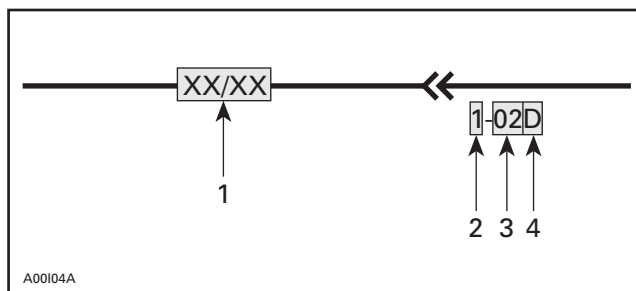

1. Wire colors
2. Housing area
3. Housing number per area
4. Wire connector location in housing

## WIRE COLORS AND CIRCUIT

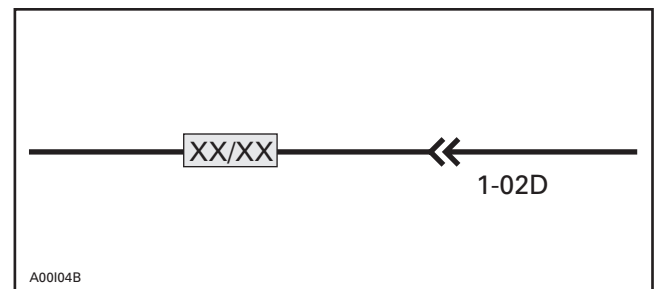

The first color of a wire is the main color, second color is the stripe.

Example: YL/BK is a YELLOW wire with a BLACK stripe.

COLOR CODE	
BE - BEIGE	OR - ORANGE
BK - BLACK	RD - RED
BL - BLUE	VI - VIOLET
BR - BROWN	WH - WHITE
GN - GREEN	YL - YELLOW
GY - GREY	

## Section 11 WIRING DIAGRAMS

### Subsection 01 (WIRING DIAGRAMS)

Following table shows wire colors related to electrical circuits.

WIRE COLOR	ELECTRICAL CIRCUIT	ADDITIONAL INFORMATION
BLACK/YELLOW	ENGINE SHUT OFF – key switch – tether cord switch – emergency switch	Must be grounded to stop engine.
BLACK (small)	Ground for shut off, RER pilot lamp, beeper and beeper switch	
BLACK (big)	Ground for starter (–)	
BEIGE	RER switch	Must be grounded to activate RER.
BEIGE/BLACK	Reverse alarm and pilot lamp	Current returns by BLACK wire.
YELLOW YELLOW/BLACK	12 volts (AC)	If shorted, magneto stops producing electricity.
RED	12 volts (DC) (+) For starter motor	
RED/GREEN	12 volts (DC) (+) For starter solenoid	
RED/BLUE	12 volts (DC) (+) Rectifier output	
GREY	12 volts (AC) High beam	Current returns by YELLOW/BLACK wire connected to headlamp.
VIOLET/GREY	12 volts (AC) Low beam	
WHITE	12 volts (AC) Brake light	Current returns by YELLOW/BLACK wire connected to taillight.
WHITE/RED	12 volts (AC) Low oil level	Current returns by YELLOW/BLACK wire connected to oil level sensor.
BLUE	12 volts (AC) Fuel level indicator	Current returns by YELLOW wire connected to fuel level sensor.
ORANGE	12 volts (AC) Heated grips (max.)	Current returns by YELLOW/BLACK wire connected to heating elements.
ORANGE/VIOLET	12 volts (AC) Heated grips (min.)	
BROWN	12 volts (AC) Heated throttle lever (max.)	
BROWN/YELLOW	12 volts (AC) Heated throttle lever (min.)	
GREEN	12 volts (AC) Temperature gauge	Current returns by YELLOW wire connected to sensor.
VIOLET	12 volts (AC) Engine overheating light	

### CONNECTOR HOUSING AREA

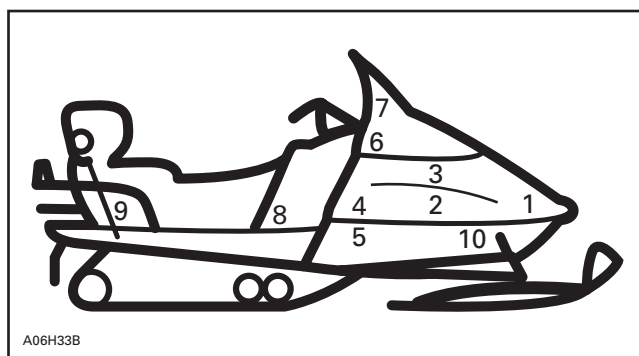
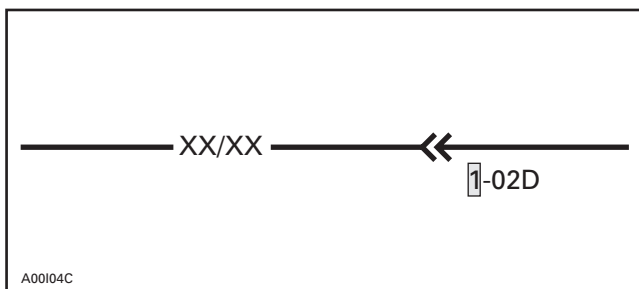

AREA	LOCATION
1	Front of engine compartment
2	Magneto
3	Carburetors
4	Near of intake silencer
5	Near driven pulley
6	Under console
7	Under hood
8	Near fuel tank
9	Rear of seat
10	Under engine

### CONNECTOR LOCATION IN HOUSING

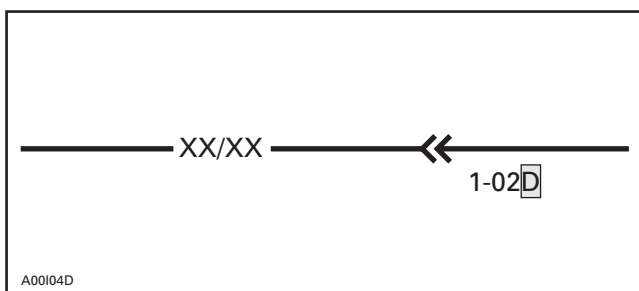





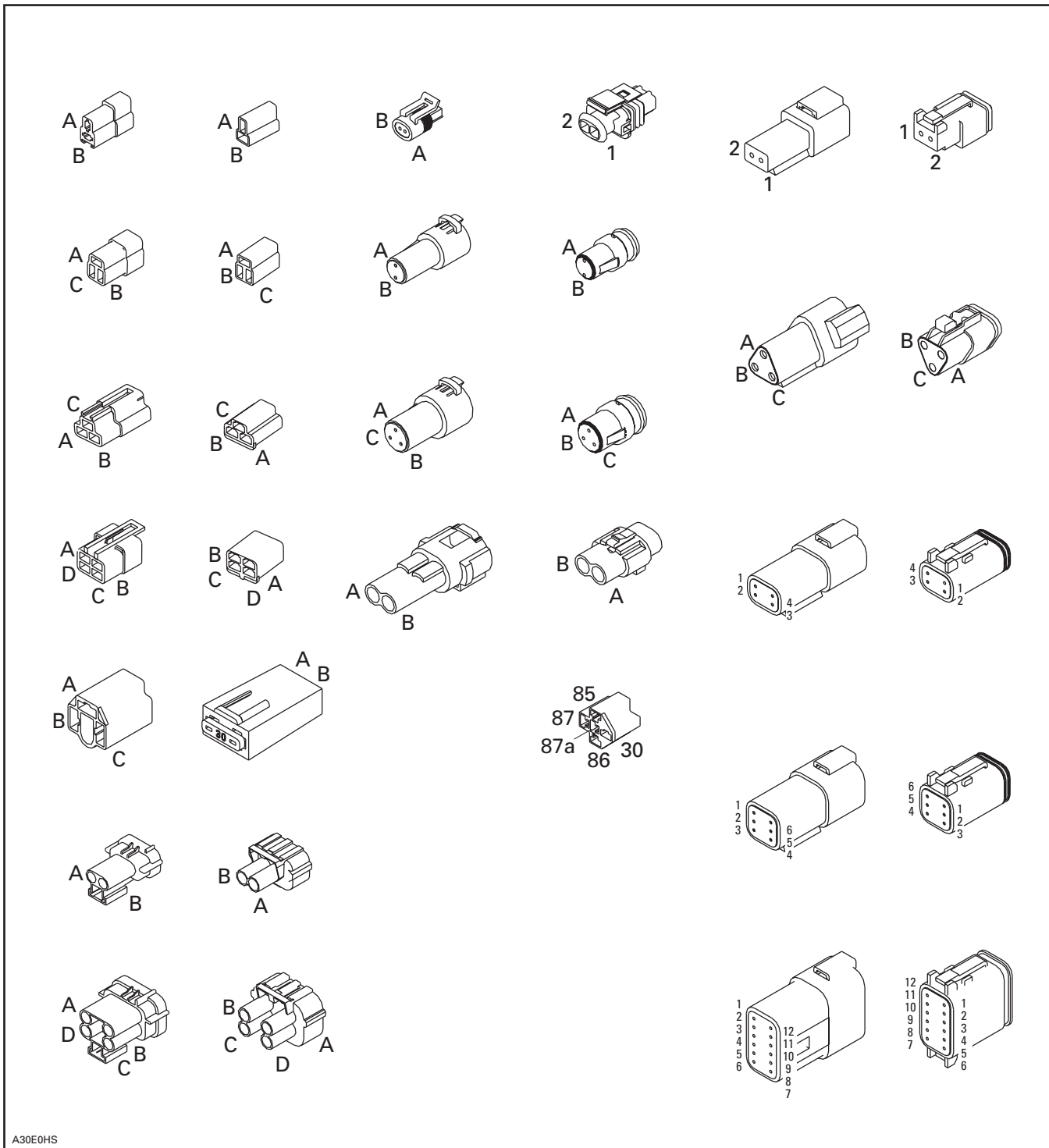





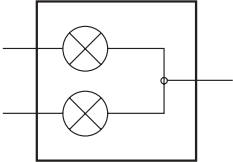
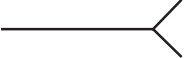
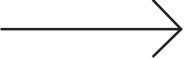

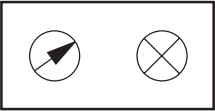
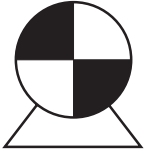
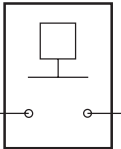
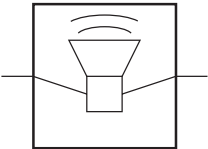
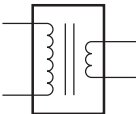
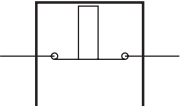
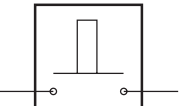

# Section 11 WIRING DIAGRAMS

## Subsection 01 (WIRING DIAGRAMS)

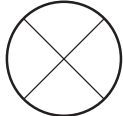
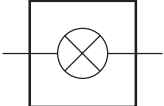
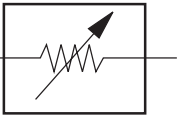
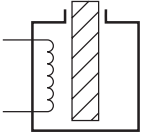

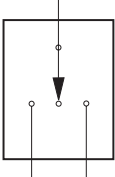
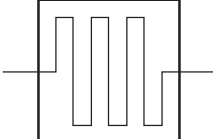
A30E0HS

**SYMBOLS DESCRIPTION**

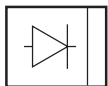
<p>Beam and tail light</p> 	<p>Female terminal</p> 	<p>Male terminal</p> 	<p>Electronic module</p> 
<p>Meter</p> 	<p>Electric motor</p> 	<p>Low level sensor</p> 	<p>Buzzer</p> 
<p>Ignition coil</p> 	<p>Normally close switch</p> 	<p>Normally open switch</p> 	<p>Male terminal on instrument</p> 
<p>Engine ground</p> 	<p>Frame ground</p> 	<p>Spark plug</p> 	<p>Meter movement</p> 
<p>Bulb</p> 	<p>Pilot lamp</p> 	<p>Analog sensor</p> 	<p>Solenoid valve</p> 
<p>Magneto (Delta)</p> 	<p>3 position switch</p> 	<p>Heating element</p> 	<p>Fuse</p> 
<p>Trigger coil</p> 	<p>Battery</p> 		<p>Diode</p> 

A00E52S

## Section 11 WIRING DIAGRAMS

### Subsection 01 (WIRING DIAGRAMS)

## UNPLUGGING CONNECTORS

Always unplug connectors by pulling on housing not on wire.



TYPICAL

## TAB AND RECEPTACLE CONNECTORS REMOVAL

### Tab Connector

It is locked in its housing by a spring tab on its side. Removal is done by squeezing this tab.

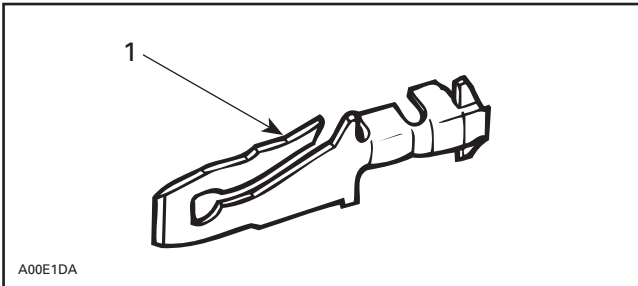

TAB CONNECTOR

1. Locking tab

To remove:

- Insert a screwdriver or Snap-on TT 600-5 from opposite side of wire and pry locking tab.
- While holding locking tab pried, pull connector toward wire side.

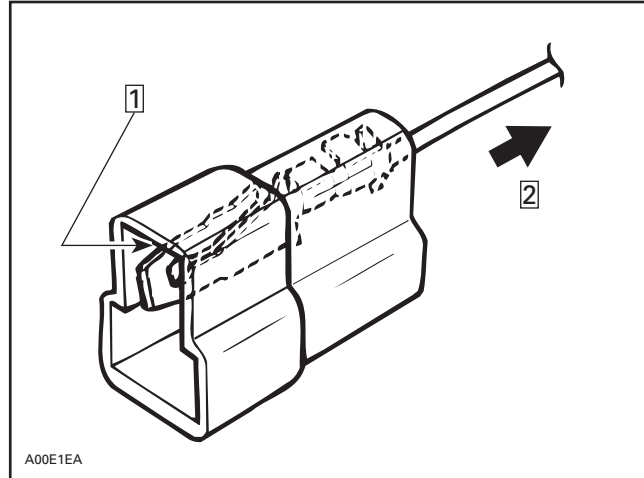

Step 1: Insert screwdriver here

Step 2: Pull this side

### Locking Receptacle Connector

To remove:

- Insert tool Snap-on TT 600-5 in access opening then pull housing toward wire side.

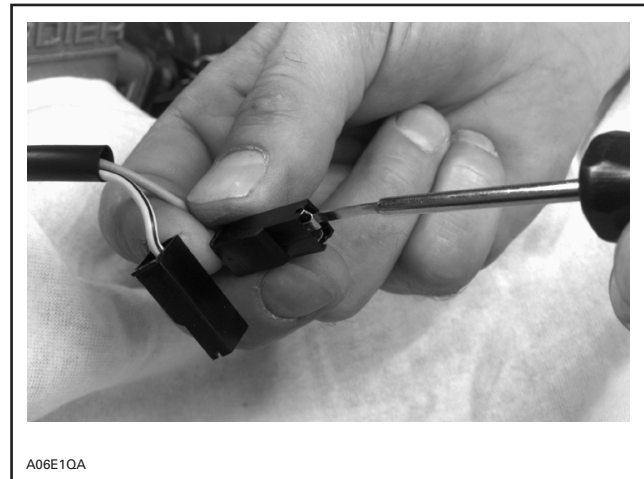

**Waterproof Connector Housing**

**Female Connector Housing**

To remove:

- Insert tool Snap-on TT 600-5 under lock and twist to lift it.

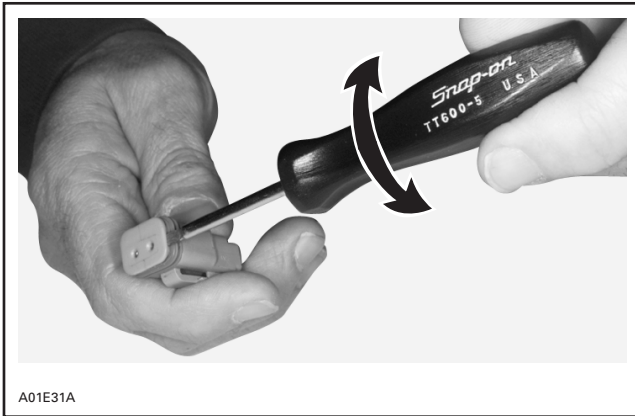

A01E31A

- Pry tab to free connector then pull wire out of housing.

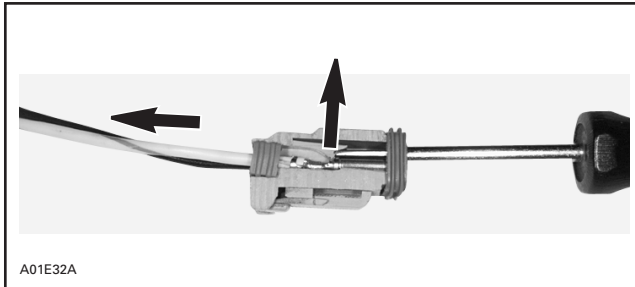

A01E32A

*FEMALE CONNECTOR HOUSING — CUT-AWAY*

**Male Connector Housing**

To remove:

- Using a small hook, pull out the lock.

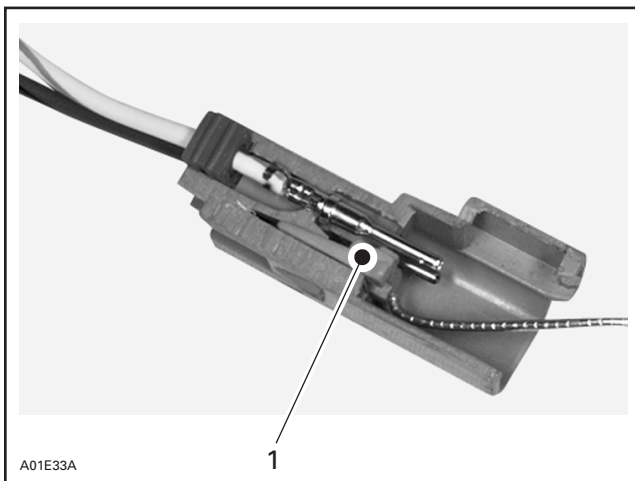

A01E33A

1. Lock

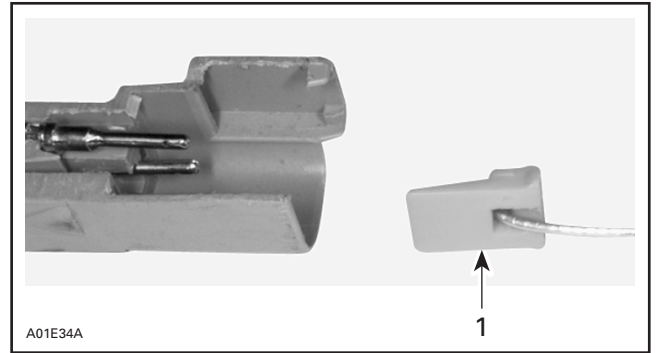

A01E34A

1. Lock

- Pry tab to free connector then pull wire out of housing.

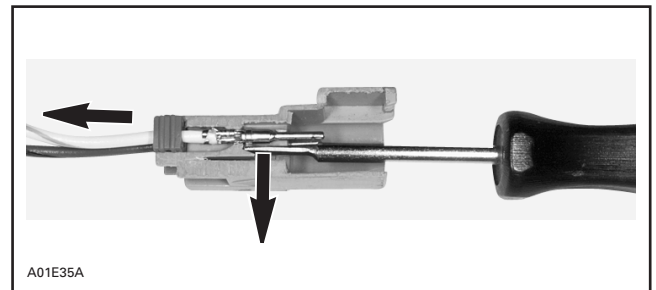

A01E35A

*MALE CONNECTOR HOUSING — CUT-AWAY*

**TAB AND RECEPTACLE CONNECTORS INSTALLATION**

Prior to installing, make sure locking tab is sufficiently lifted to properly lock.

Insert tab and receptacle connectors in their respective housings as shown in following illustrations. Push sufficiently so that they snap. Try pulling wire to ensure they are properly locked.

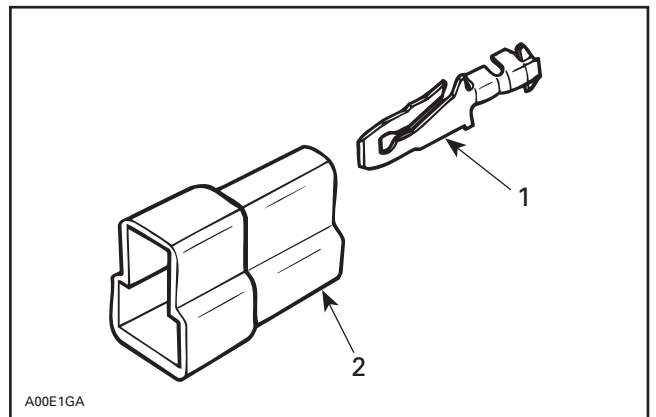

A00E1GA

1. Tab  
 2. Housing

---

## Section 11 WIRING DIAGRAMS

### Subsection 01 (WIRING DIAGRAMS)

---

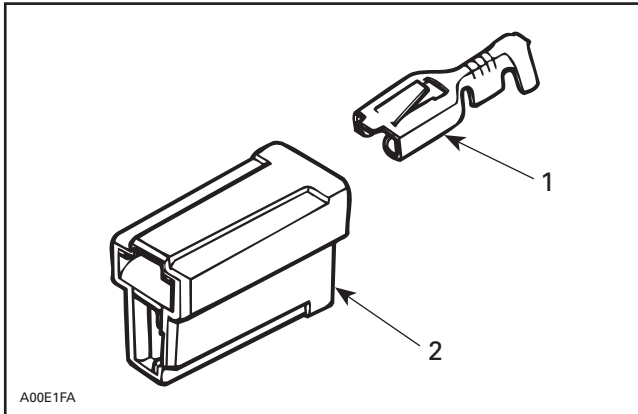

**TYPICAL**

1. Receptacle
2. Housing

## ACCESSORIES INSTALLATION

On all **electric start models**: The direct current (DC) utilizes the snowmobile frame as ground "wire" while all alternating current (AC) consumers (lights, heated grips, fuel gauge, etc.) utilize a separate ground wire.

Never interconnect AC and DC grounds as an AC voltage drop will result. When installing accessories on **any** snowmobile, connect their wires directly to the YELLOW and YELLOW/BLACK lighting coil wires.

Even if **manual start models** have an AC ground to the chassis (on voltage regulator), all accessories utilize a ground wire isolated from chassis. When an electric starter kit is installed, the voltage regulator and its ground wire are replaced by a voltage rectifier/regulator unit permitting a completely isolated AC circuit.

### ◆ WARNING

Never secure electrical wires/cables with fuel lines. Keep wires away from any rotating, moving, heating, vibrating or sharp edge. Use proper fastening devices as required.



**ANNEX 1**

**SKANDIC WT/SWT**

SKANDIC WT '99  
 SKANDIC SWT '99

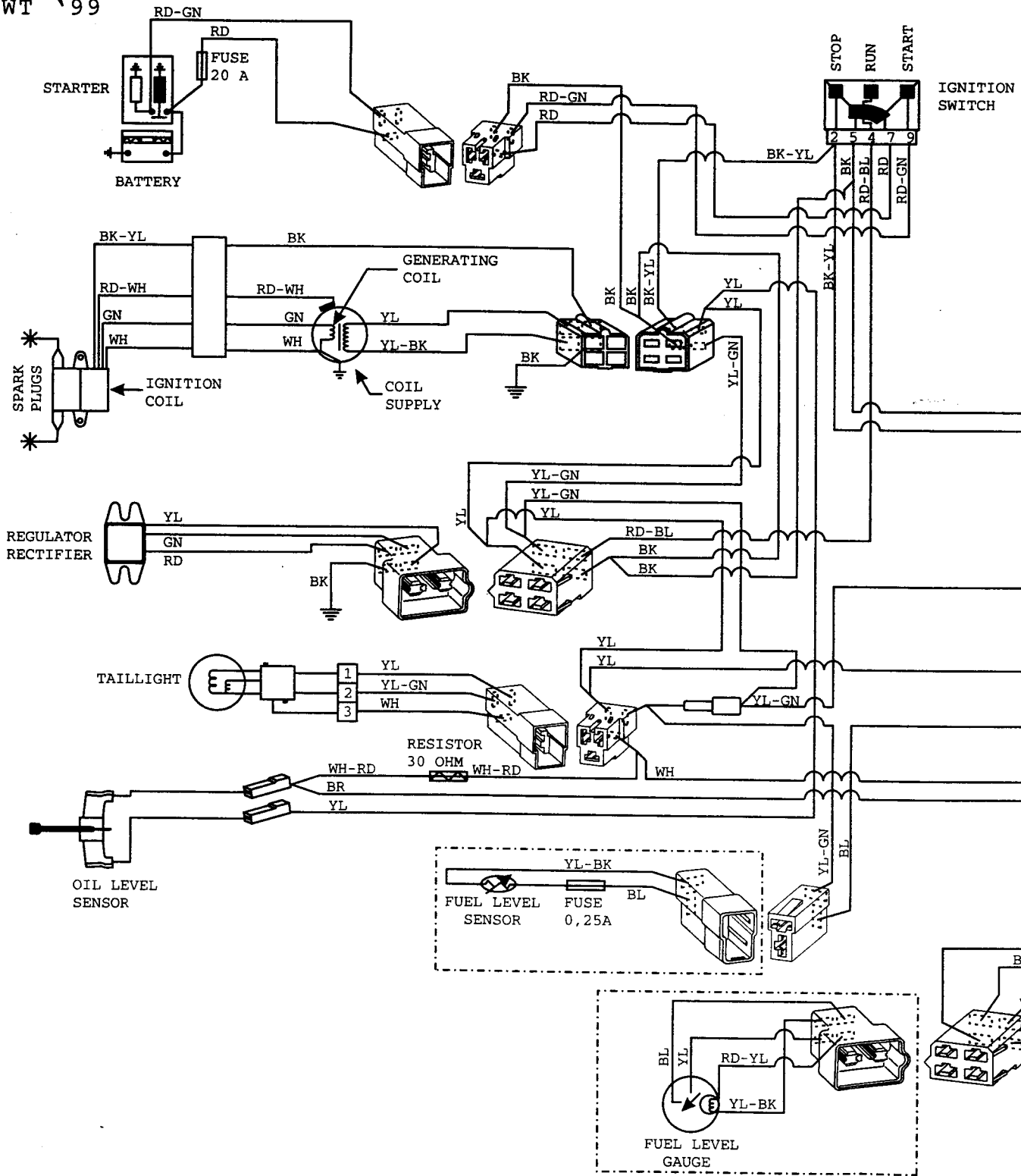



**ANNEX 2**

**SKANDIC WT LC**

SKANDIC WT LC '99

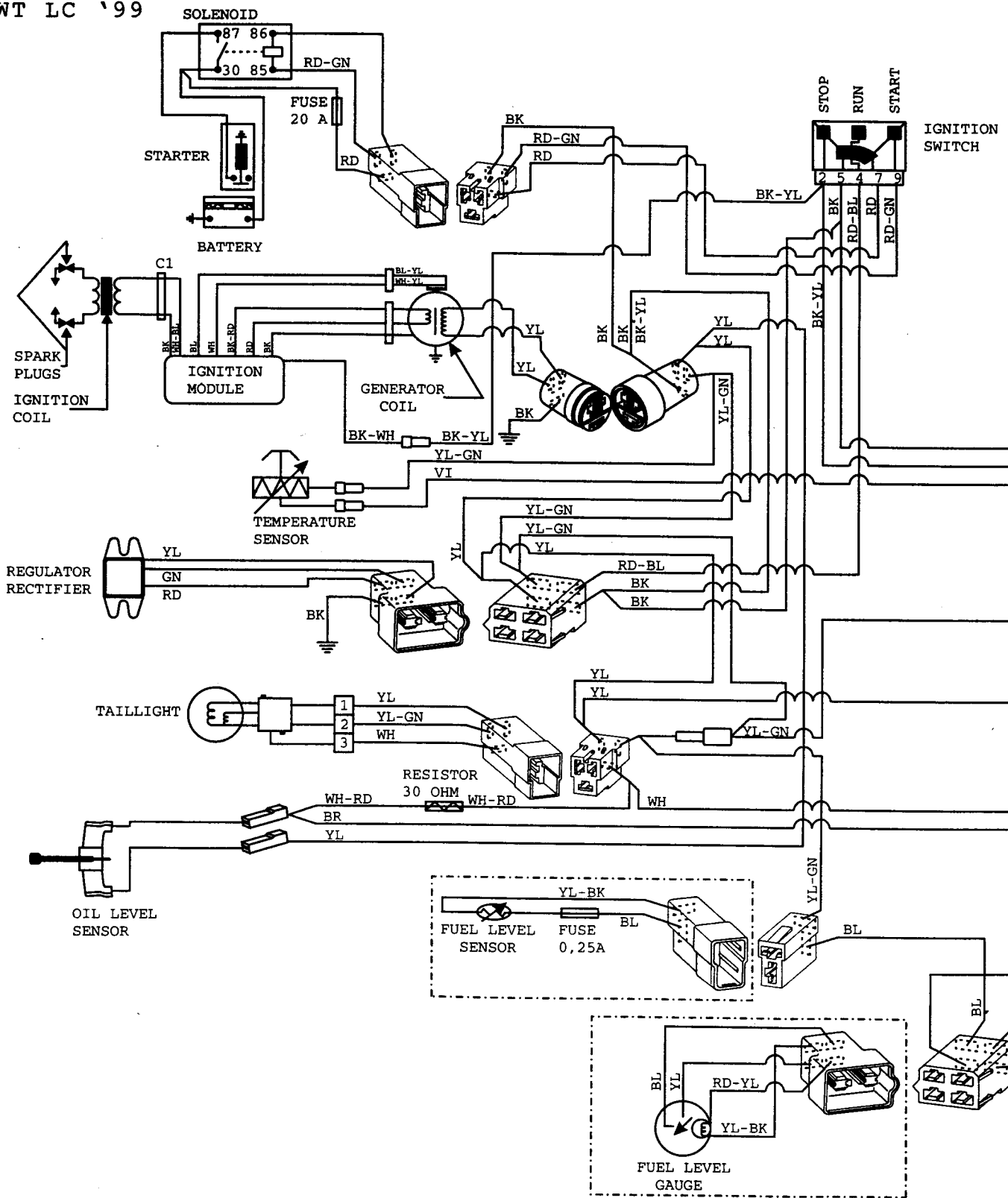

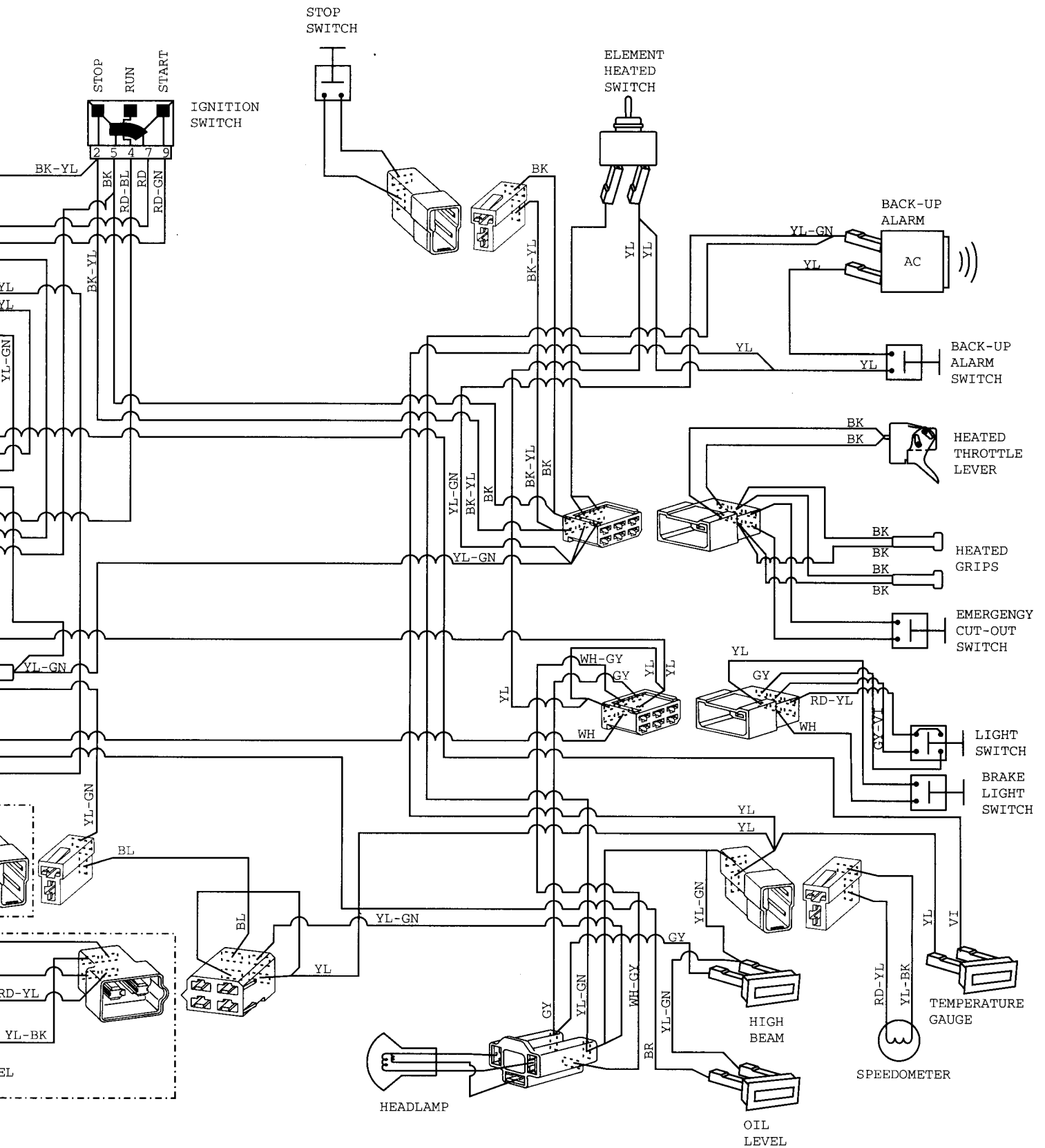

**ANNEX 3**

**MX Z 440**

# '99 MXZ 440

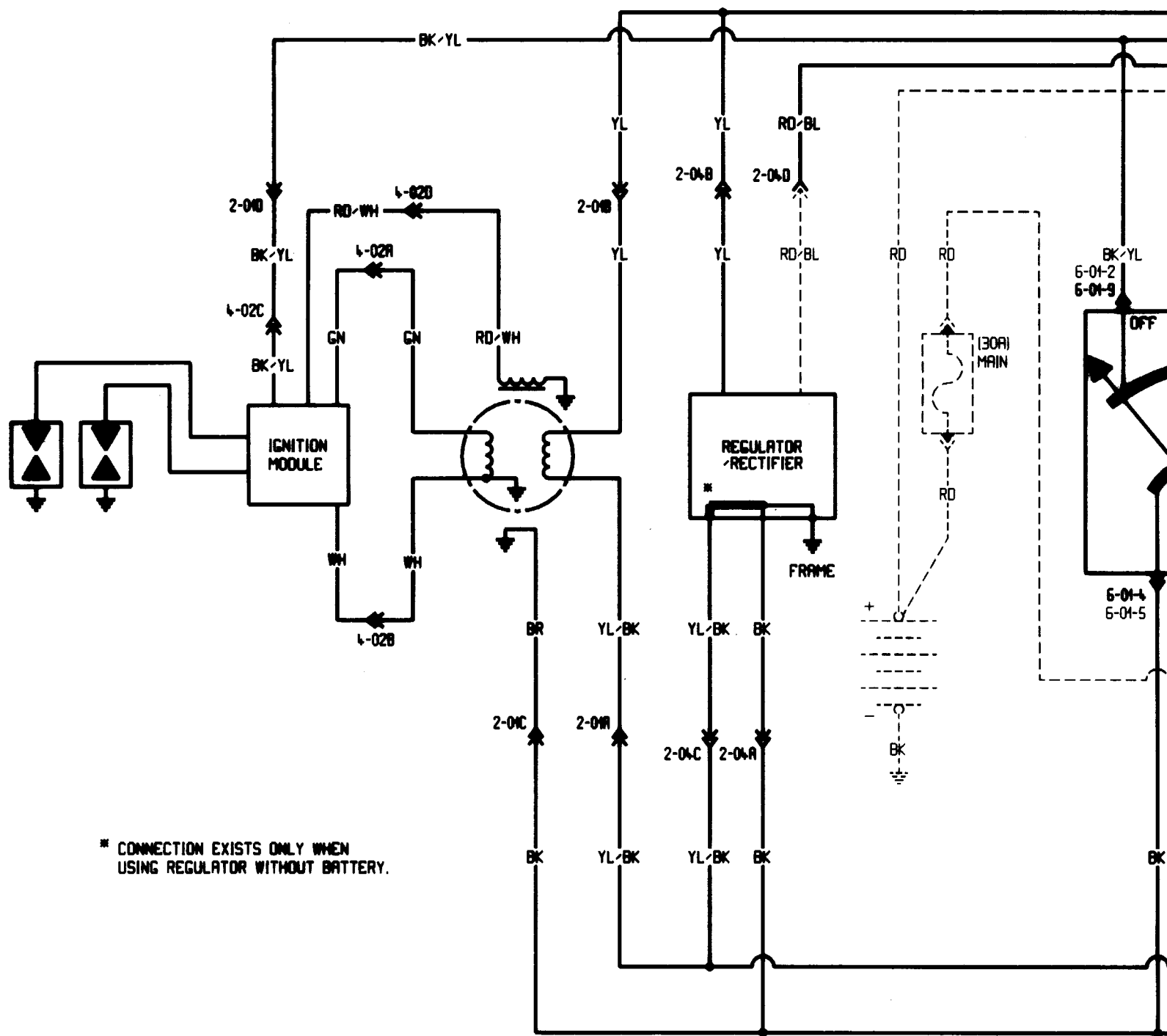

\* CONNECTION EXISTS ONLY WHEN USING REGULATOR WITHOUT BATTERY.

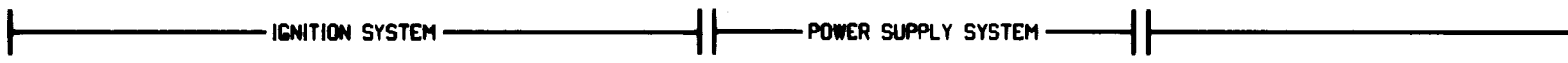



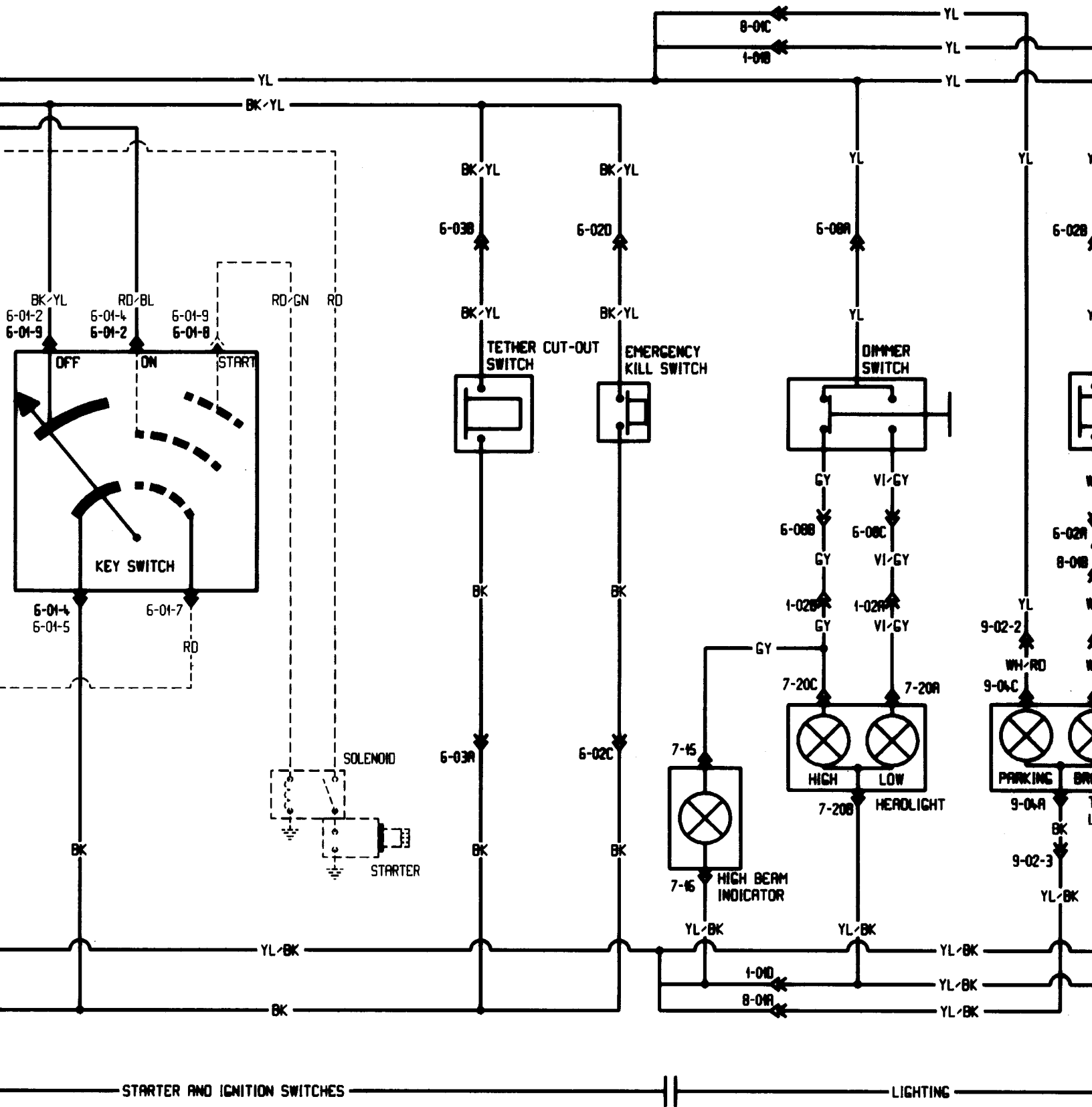

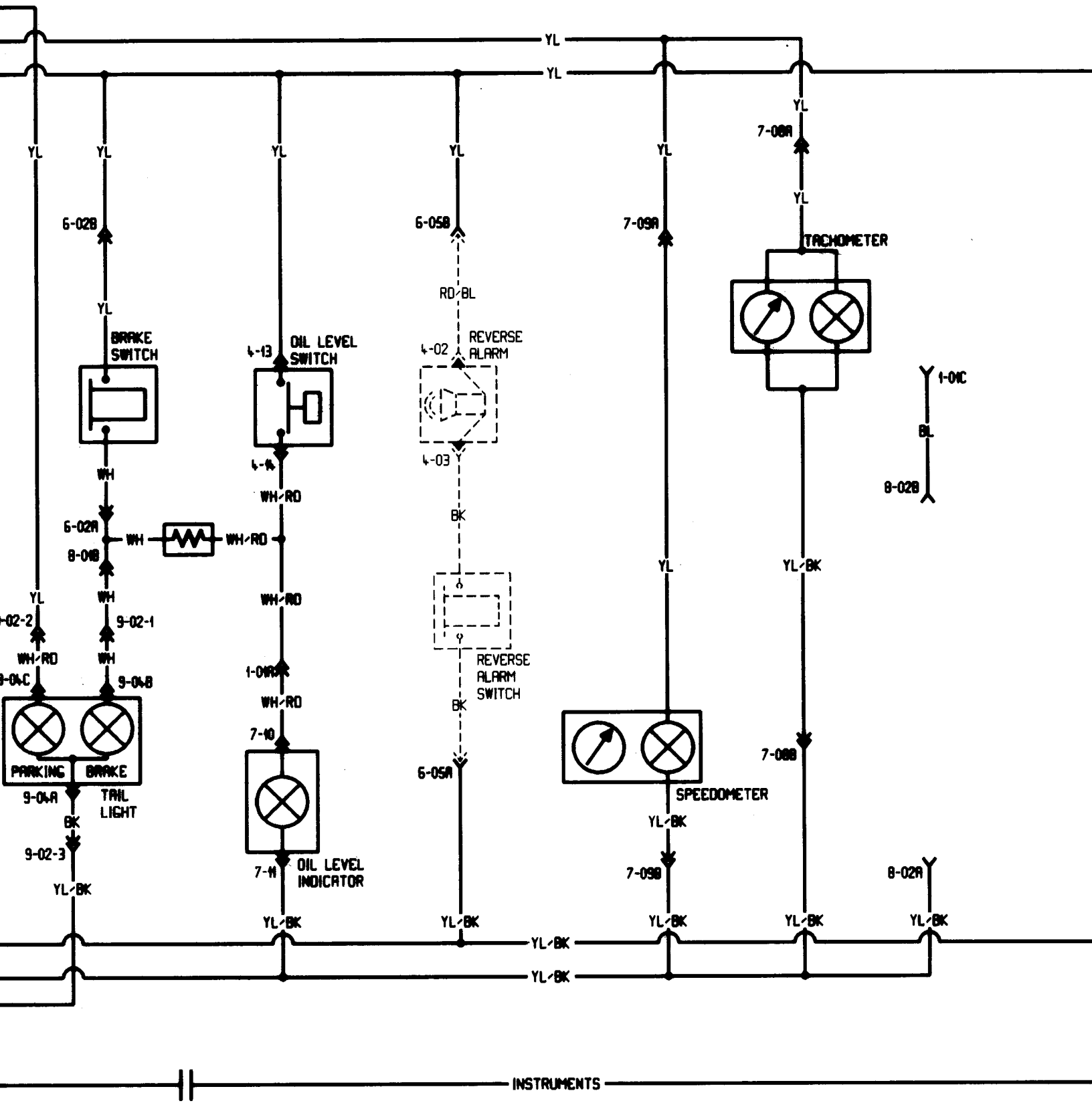

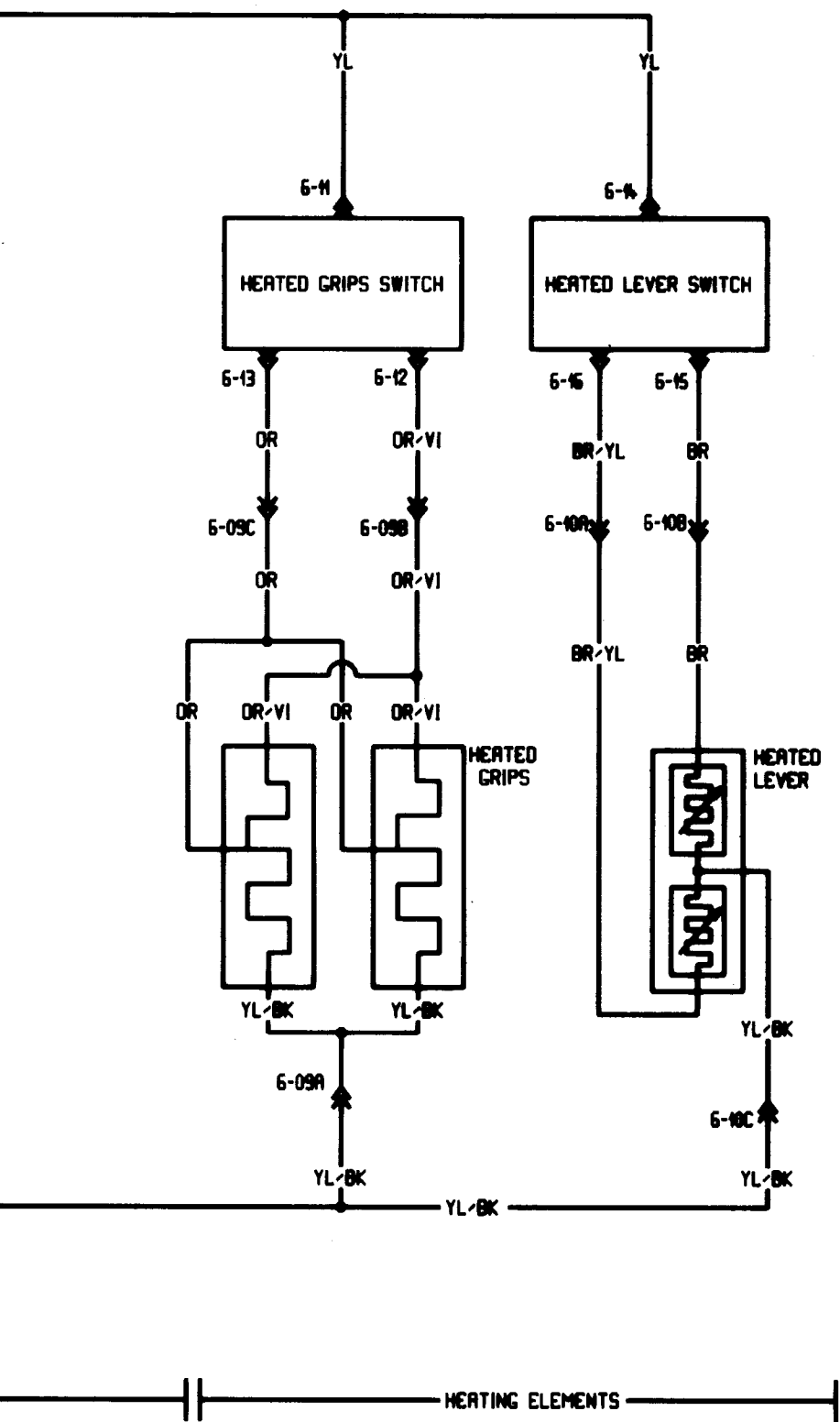

# **ANNEX 4**

**FORMULA Z 500/583/670  
MX Z 500 AND SUMMIT 500**

'99 FORMULA Z 500/583/670

'99 MXZ 500

'99 SUMMIT 500

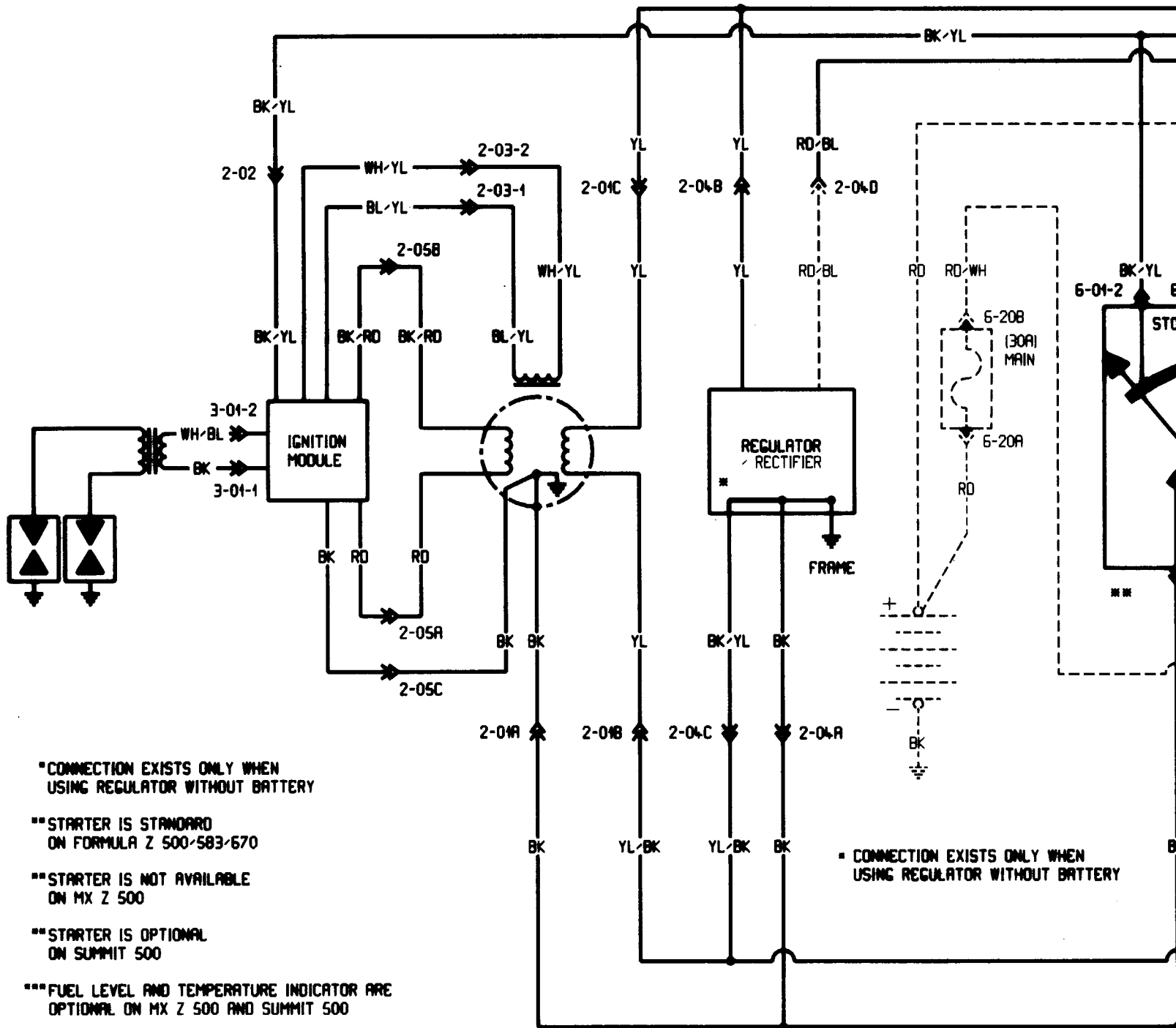

\* CONNECTION EXISTS ONLY WHEN USING REGULATOR WITHOUT BATTERY

\*\* STARTER IS STANDARD ON FORMULA Z 500/583/670

\*\*\* STARTER IS NOT AVAILABLE ON MX Z 500

\*\*\*\* STARTER IS OPTIONAL ON SUMMIT 500

\*\*\*\*\* FUEL LEVEL AND TEMPERATURE INDICATOR ARE OPTIONAL ON MX Z 500 AND SUMMIT 500

IGNITION SYSTEM

POWER SUPPLY SYSTEM

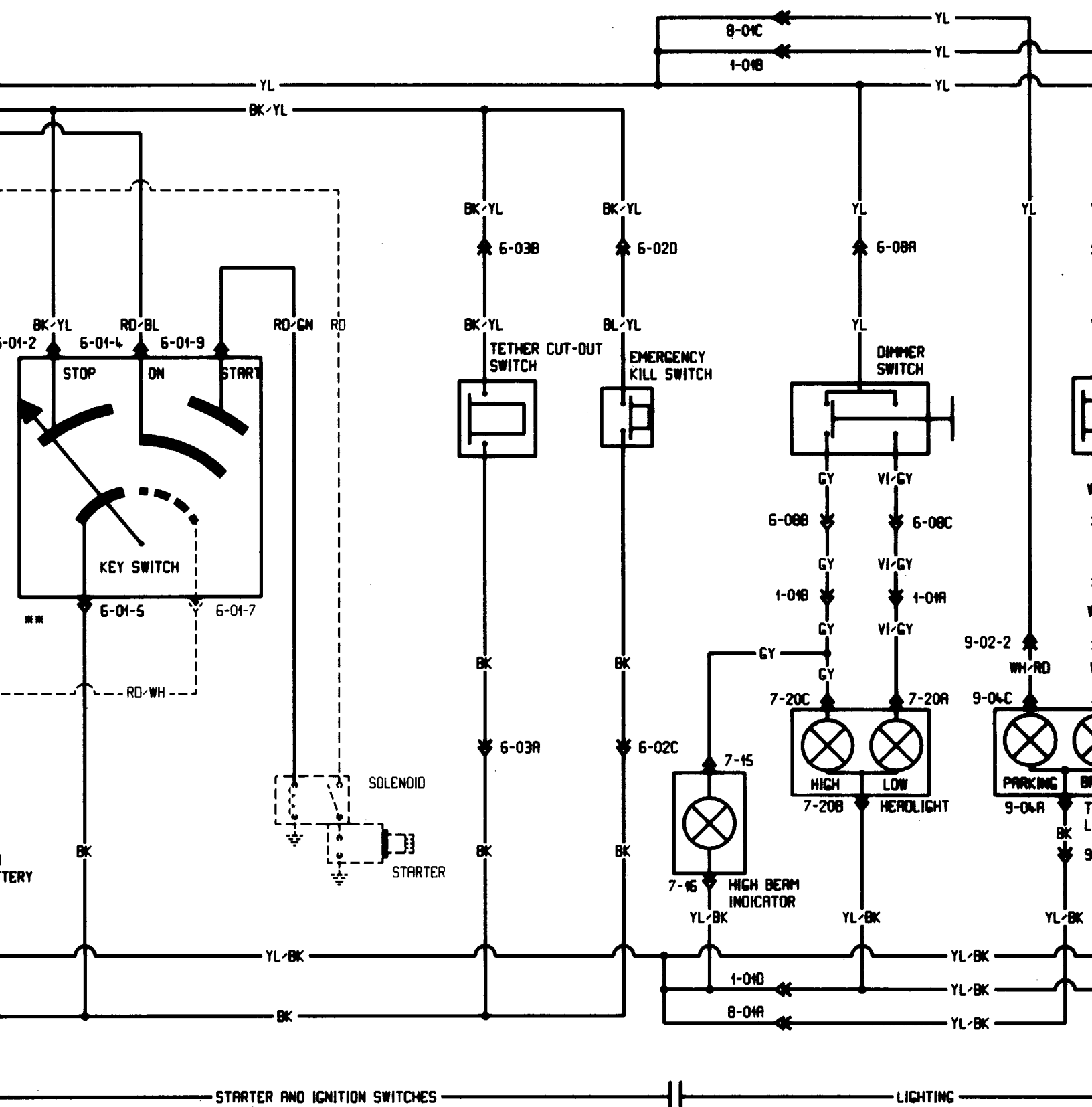

STARTER AND IGNITION SWITCHES

LIGHTING

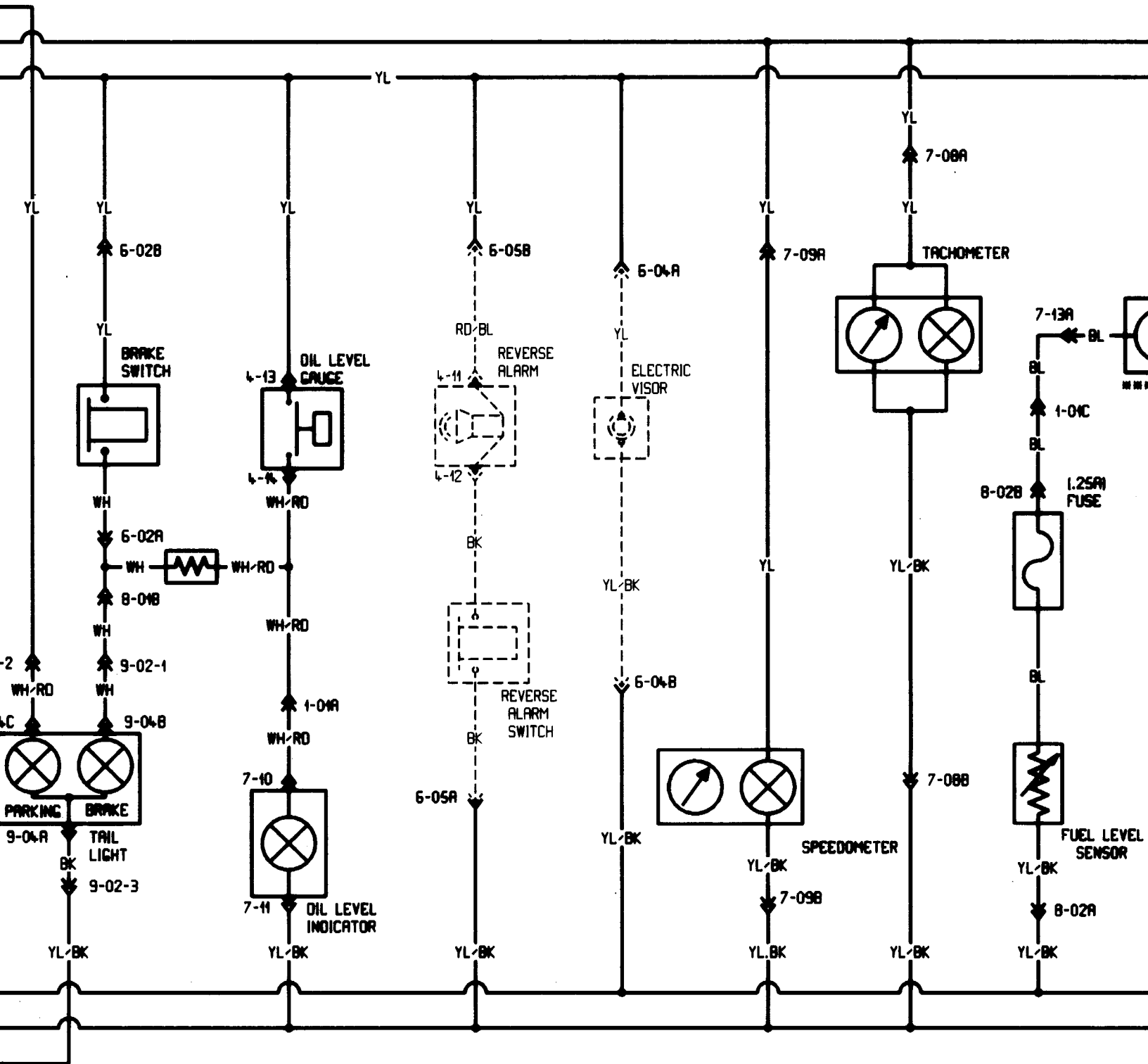

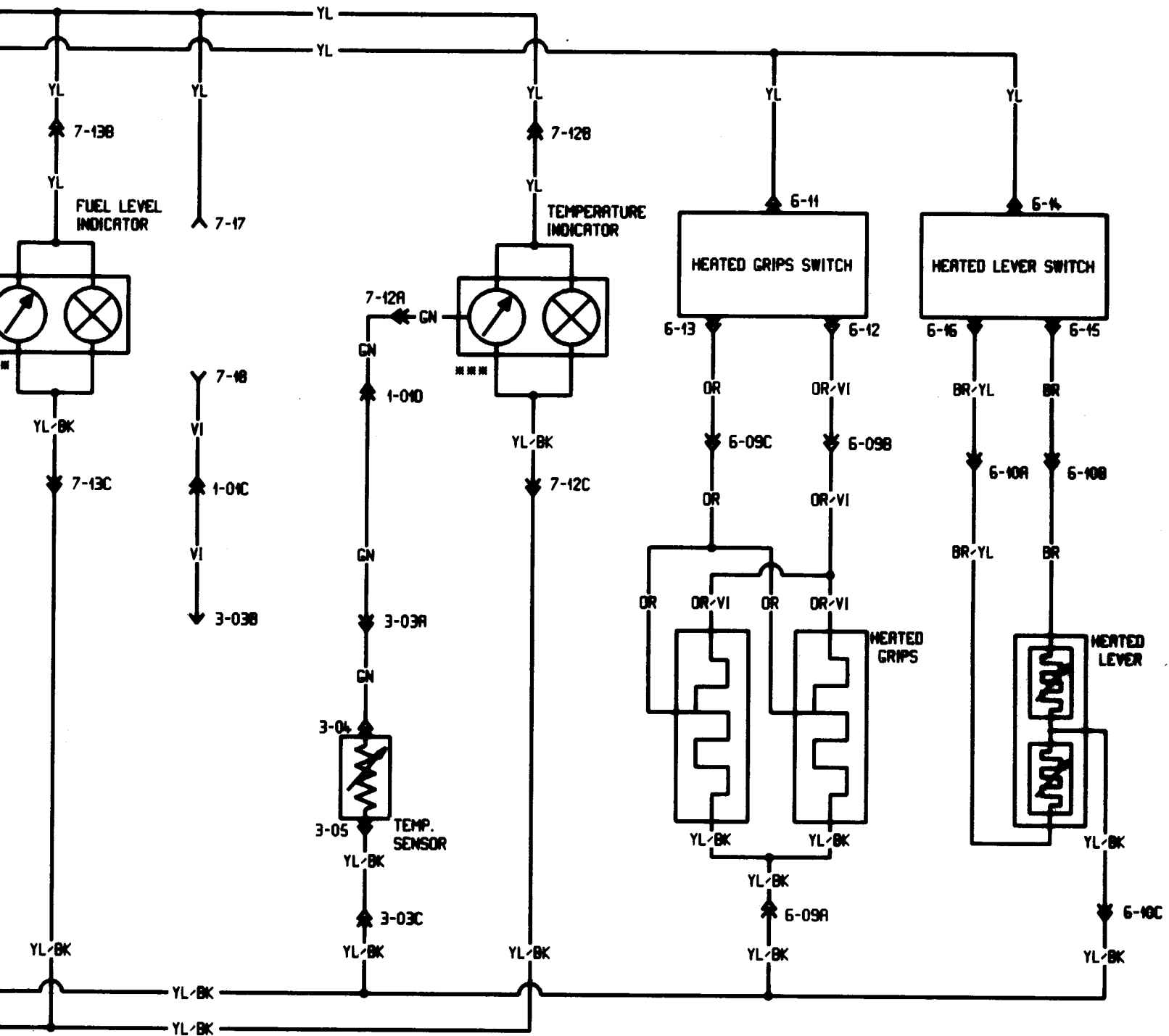

HEATING ELEMENTS



**ANNEX 5      FORMULA DLX 500/583/670**

# '99 FORMULA DLX 500/588/670

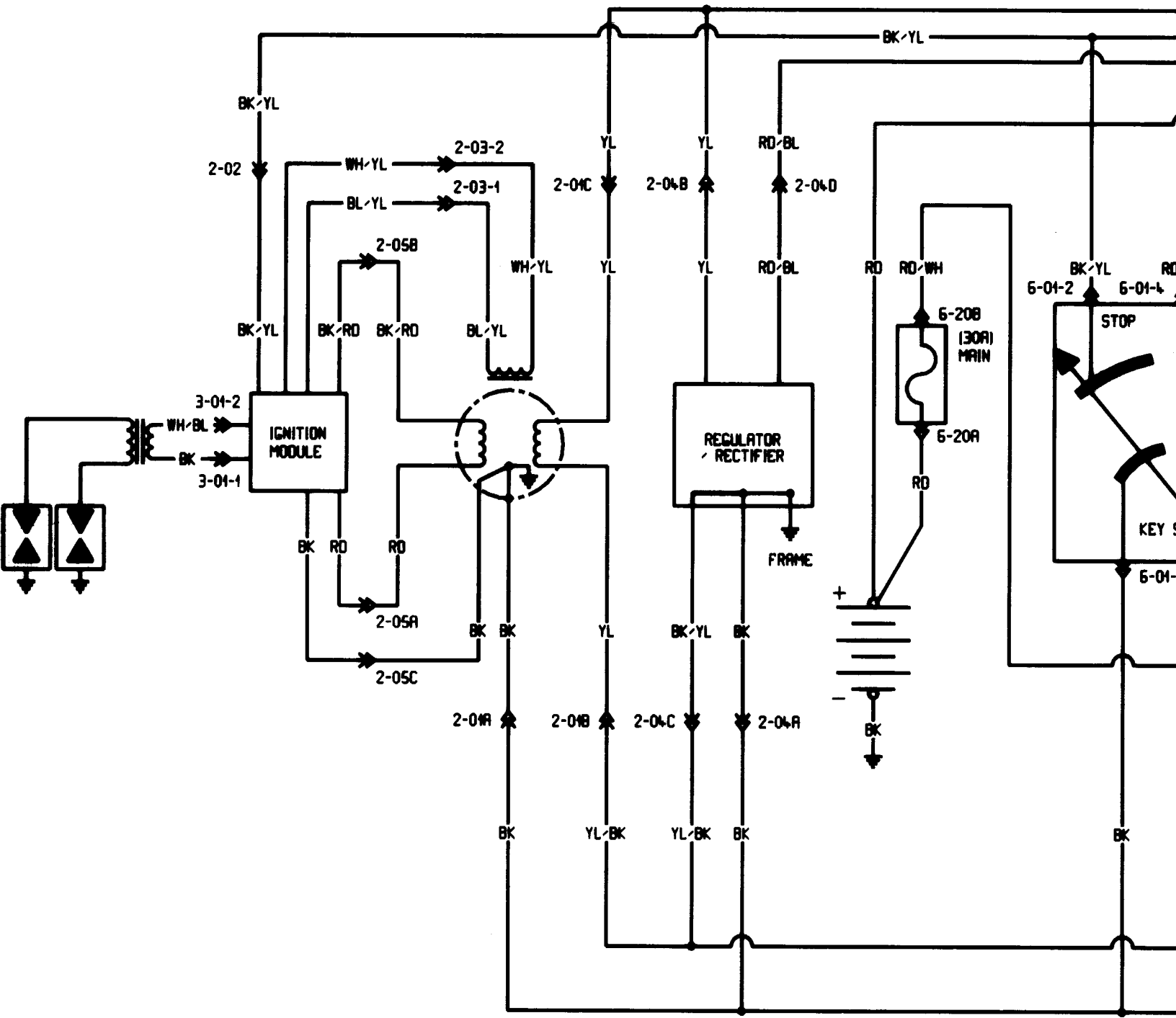

IGNITION SYSTEM

POWER SUPPLY SYSTEM

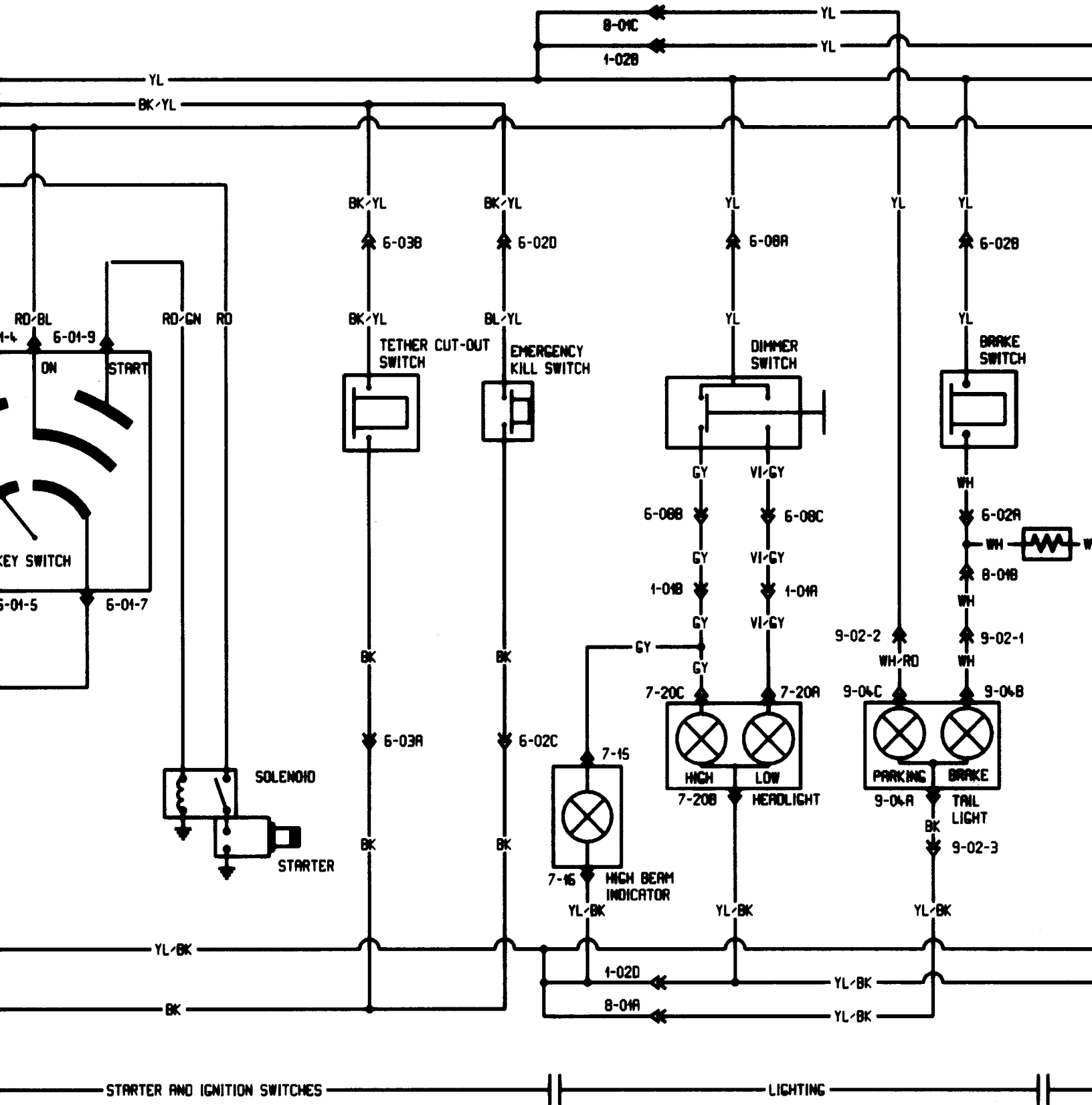

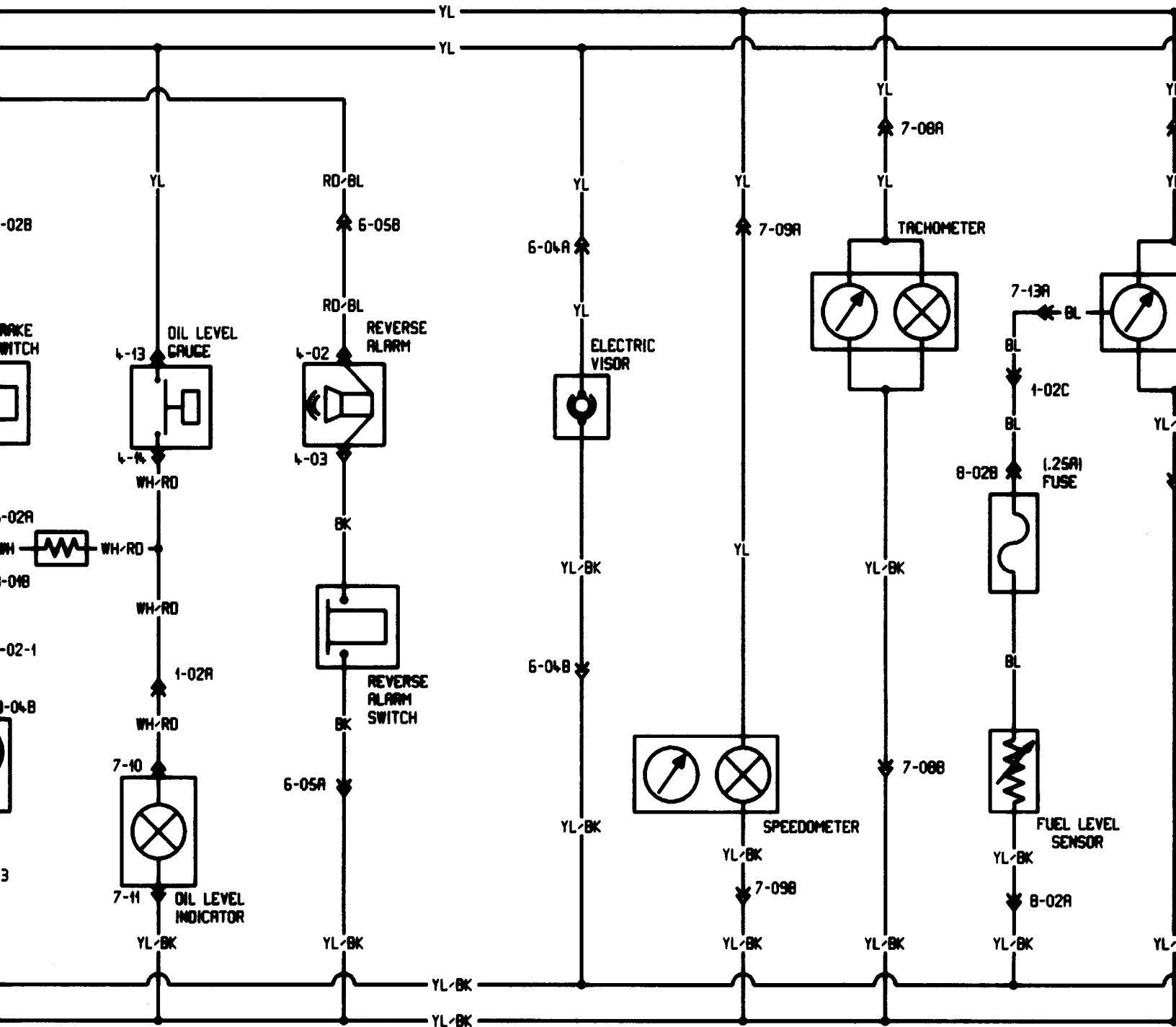

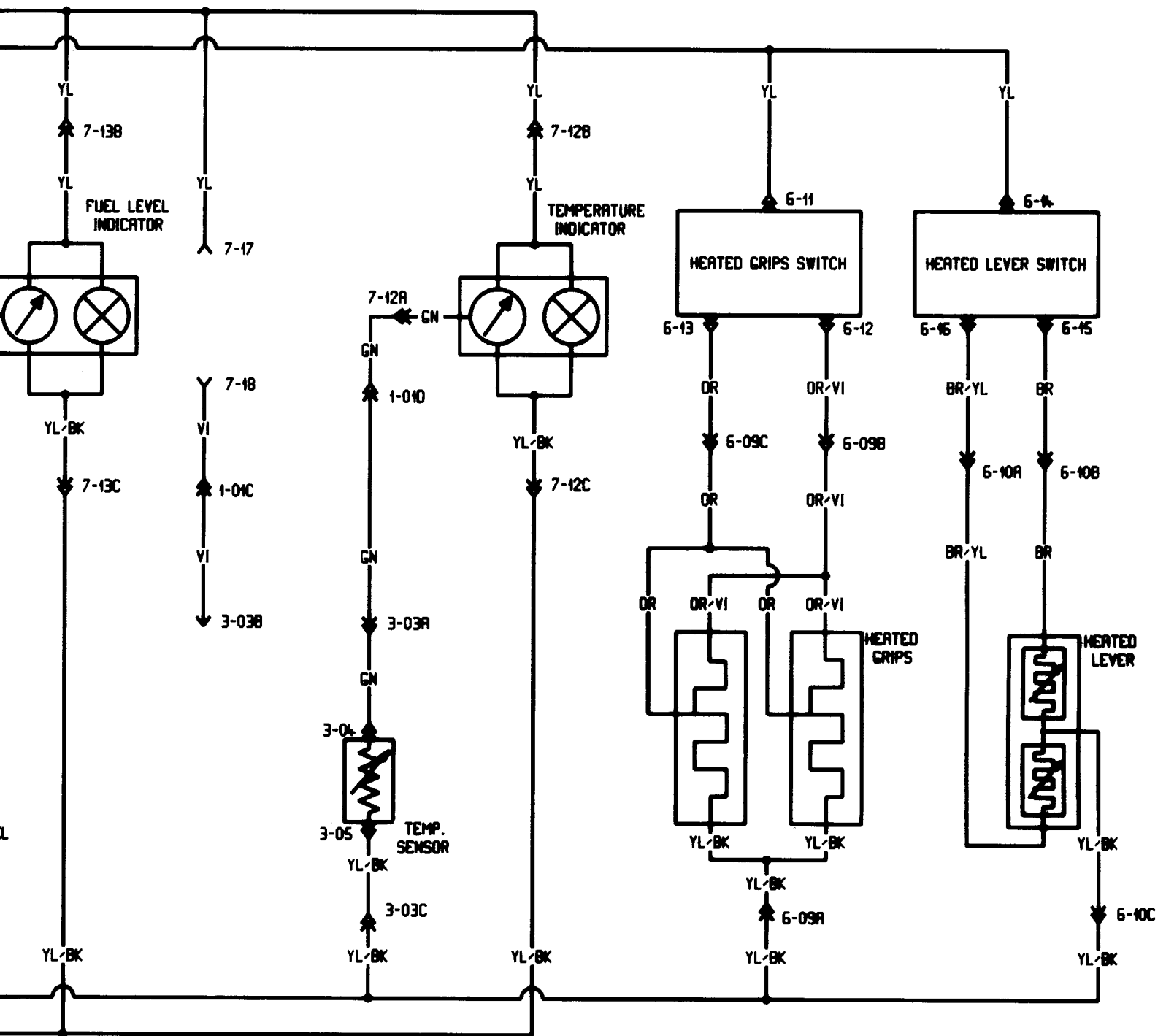

HEATING ELEMENTS

# **ANNEX 6**

# **MX Z 670 HO AND SUMMIT X 670**







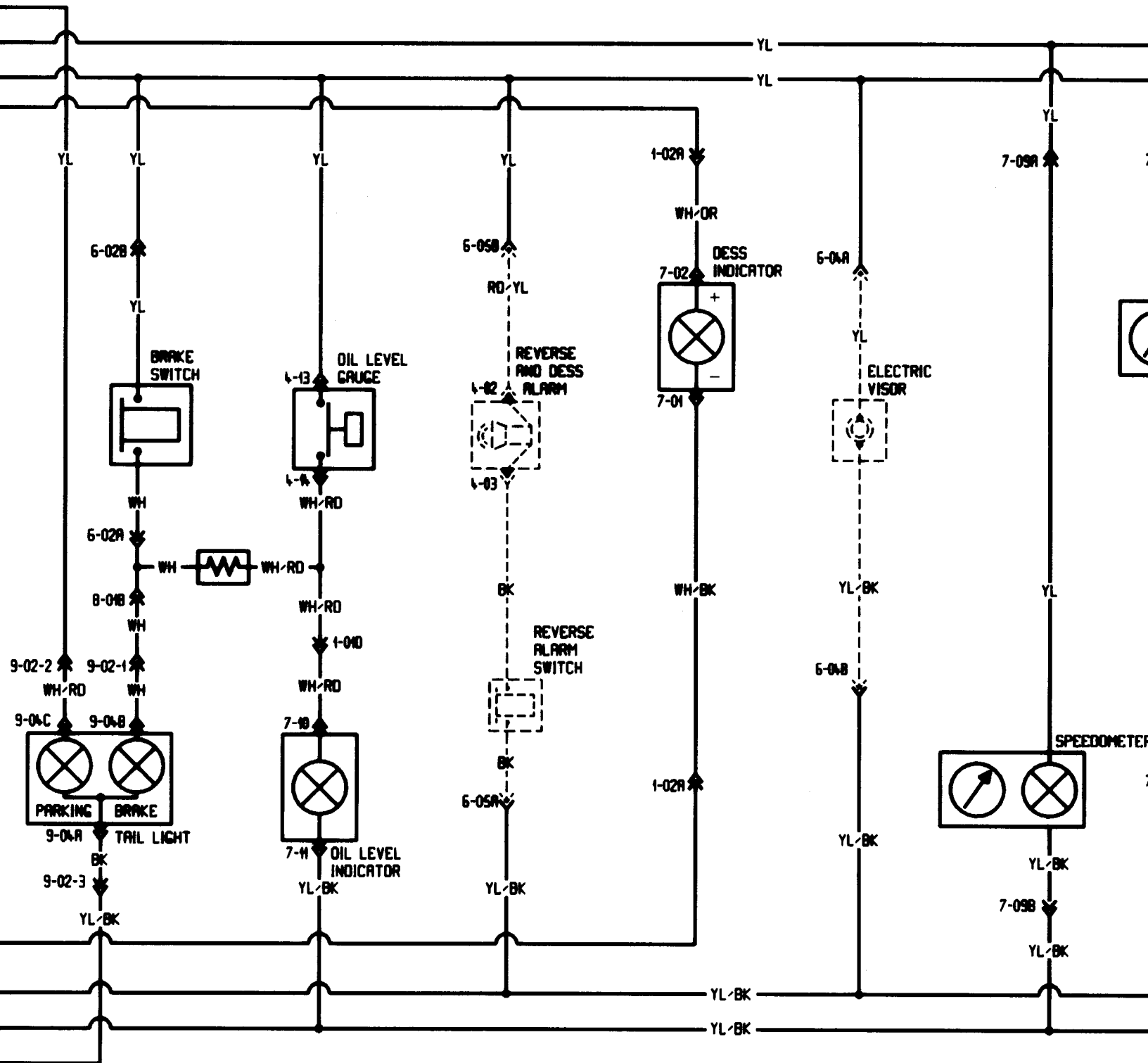

INSTRUMENTS

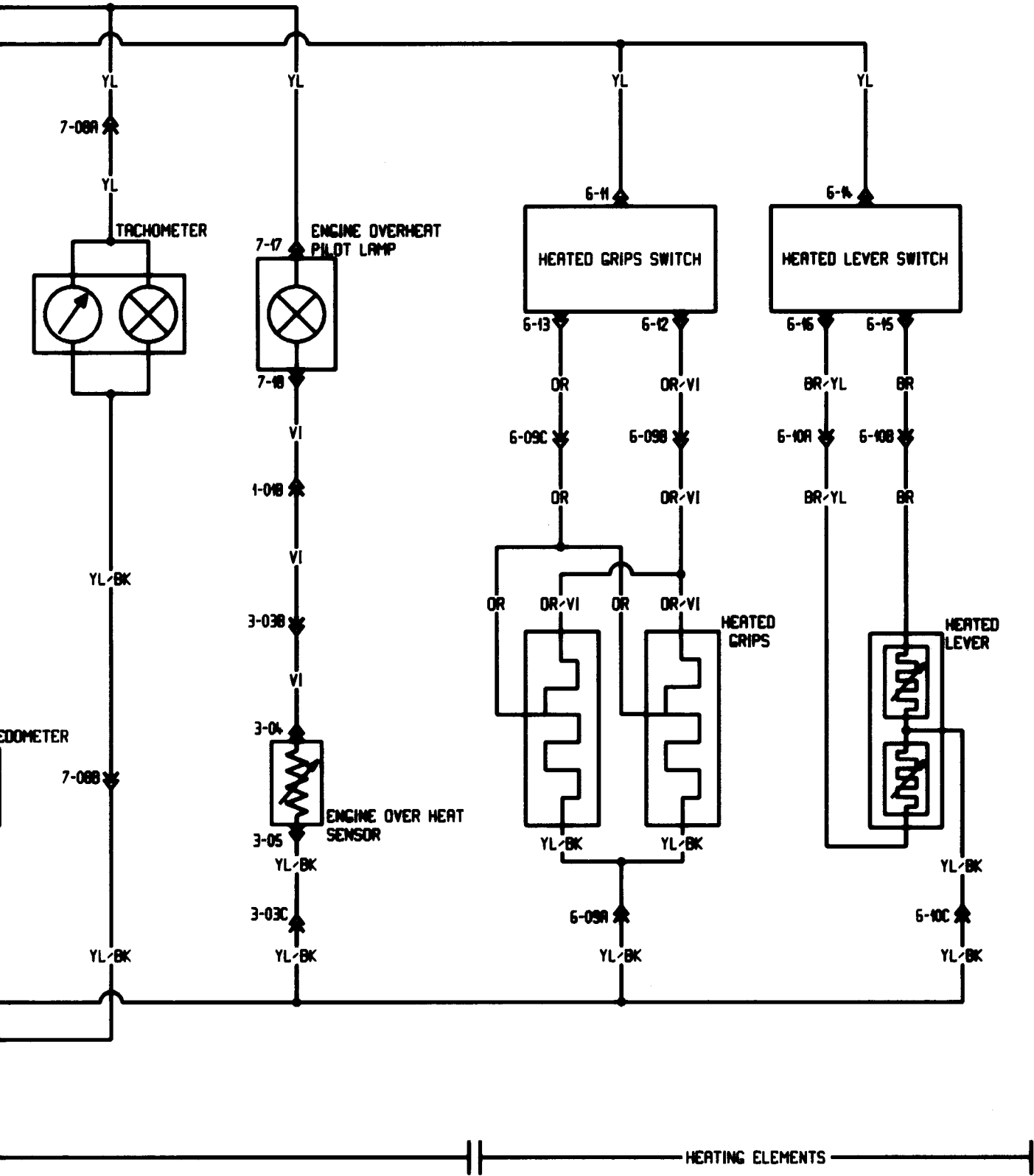

**ANNEX 7**

**GRAND TOURING 500/583**

# '99 GRAND TOURING 500/583

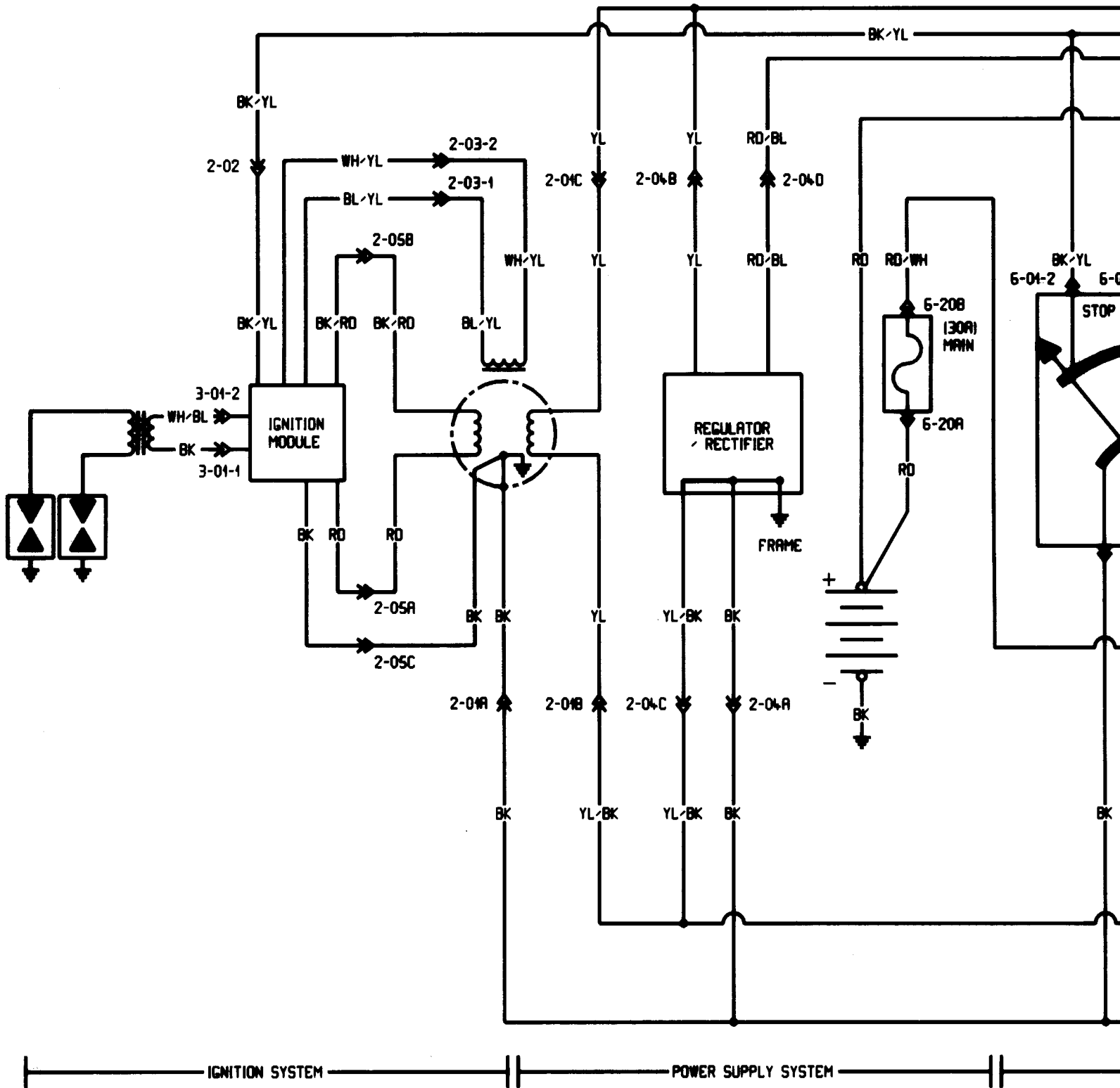

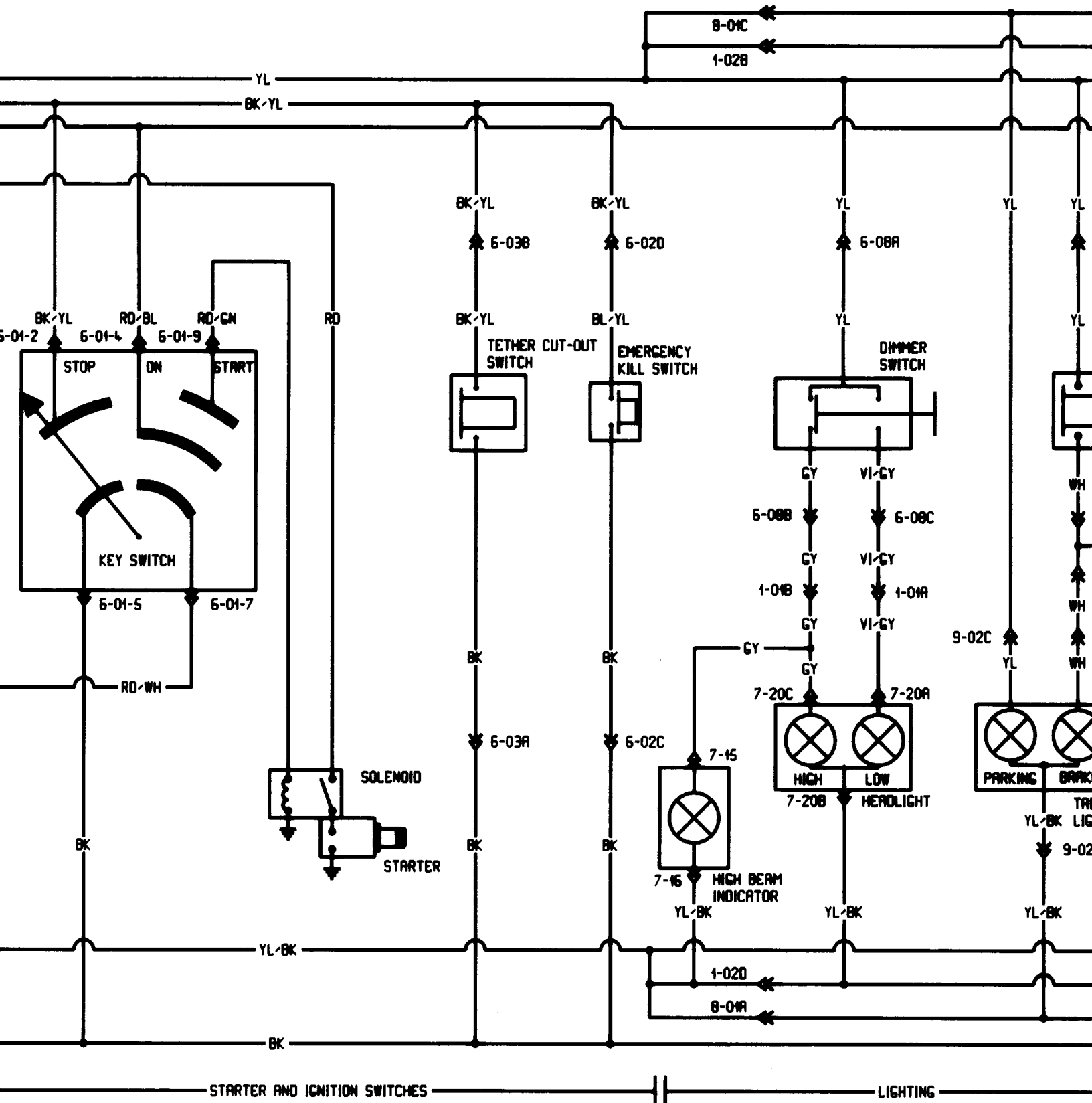

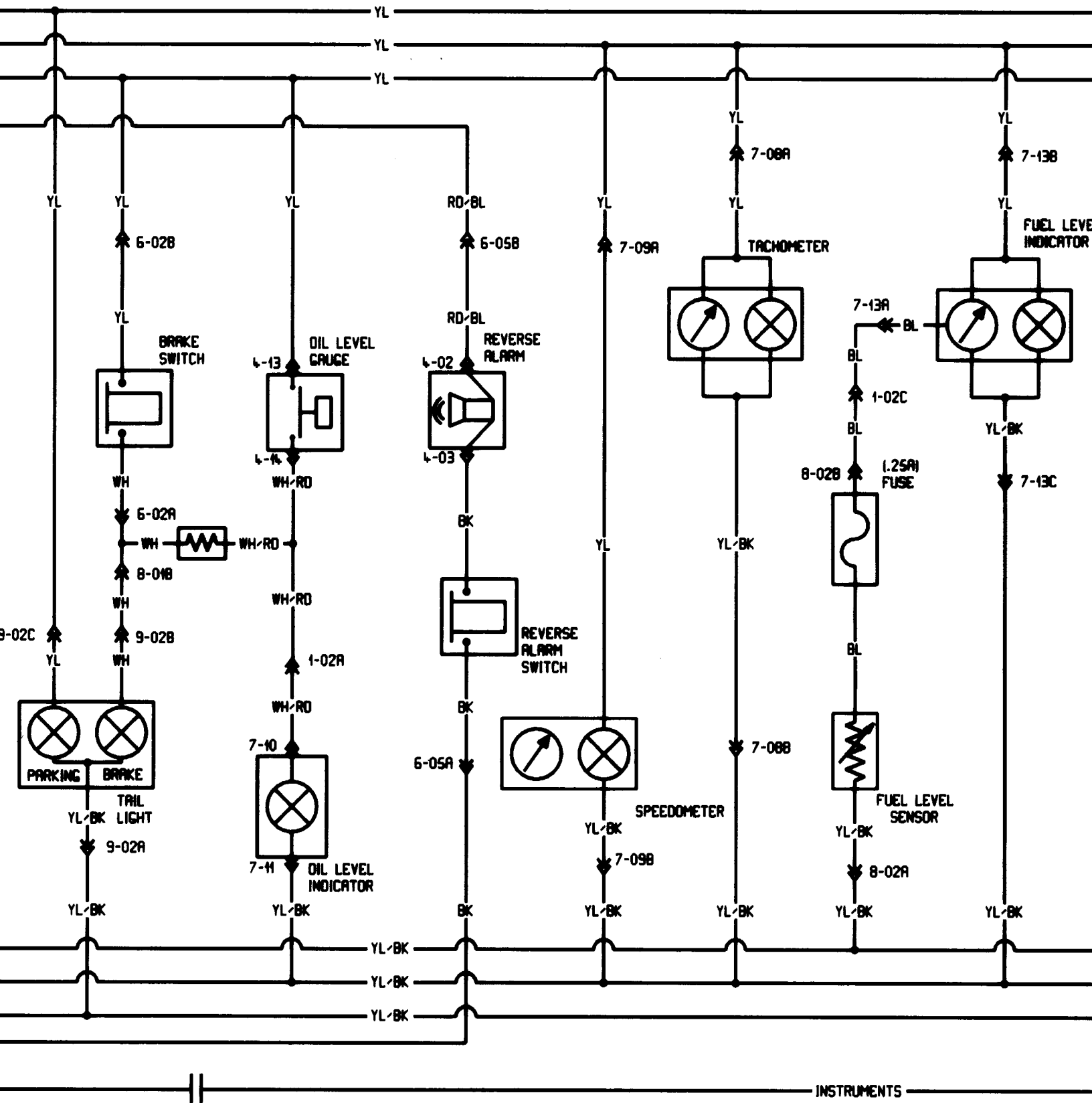

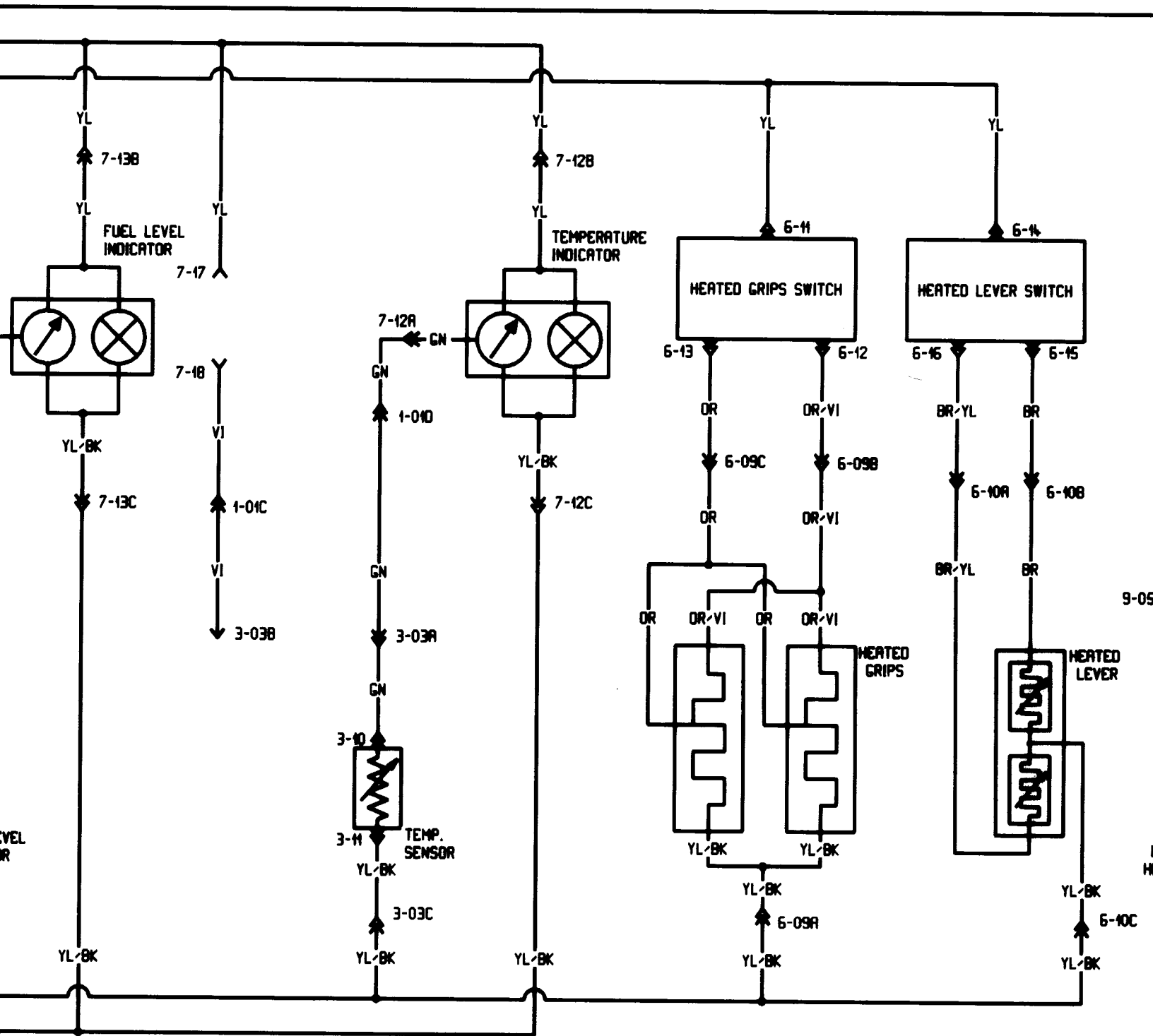

HEATING ELEMENTS

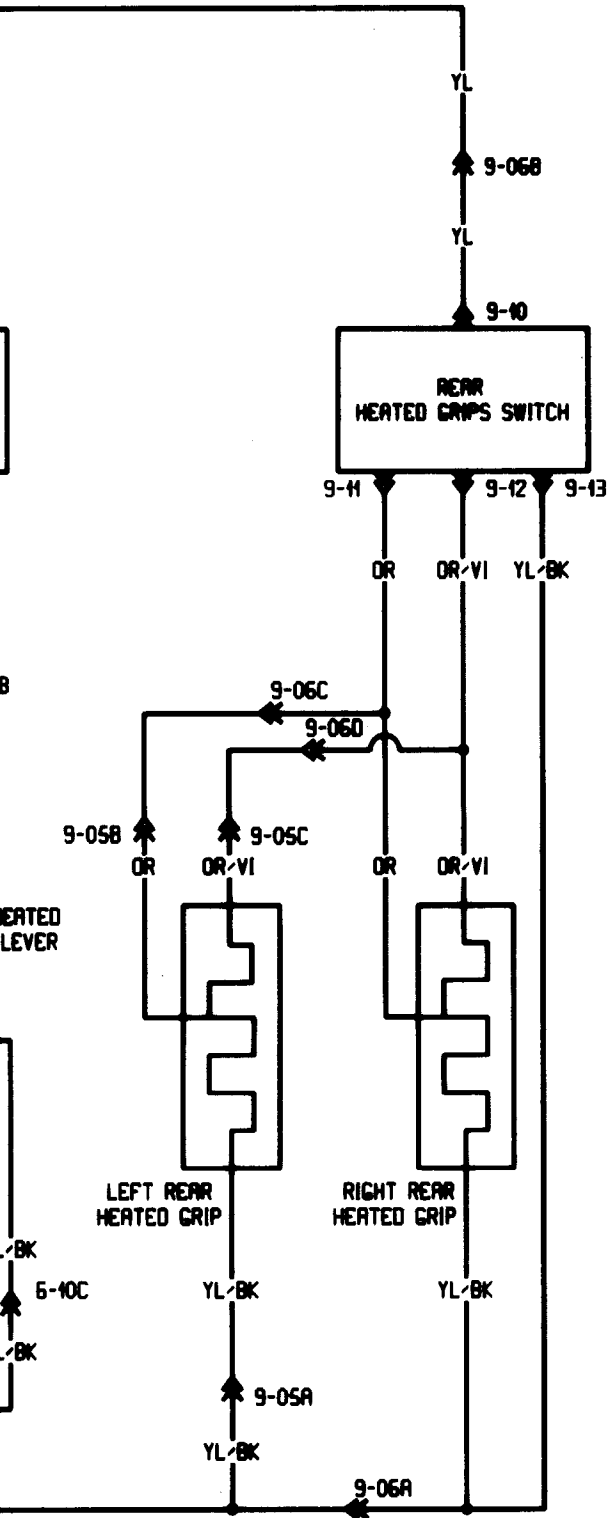





**BOMBARDIER**  
*RECREATIONAL PRODUCTS*

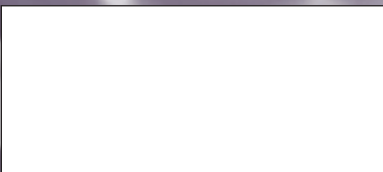

®\*Trademarks of Bombardier Inc.  
© 1998 Bombardier Inc. All Rights Reserved  
Litho'd in Canada

*VERSION FRANÇAISE ÉGALEMENT DISPONIBLE*