



**HIGH PROFILE TRACK KIT
(P/N 861 770 600)**

◆ WARNING

For safety reasons, this kit must be installed by an authorized Bombardier snowmobile dealer. Should removal of a locking device be required when undergoing disassembly/assembly, always replace with a new one. This instruction sheet should be given to the purchaser. This kit is designed for specific applicable models only. It is not recommended for units other than those for which it was sold.

NOTE: Installation time is approximately 2.5 hours.

▼ CAUTION

This kit is designed for deep snow application only.

PARTS TO BE INSTALLED

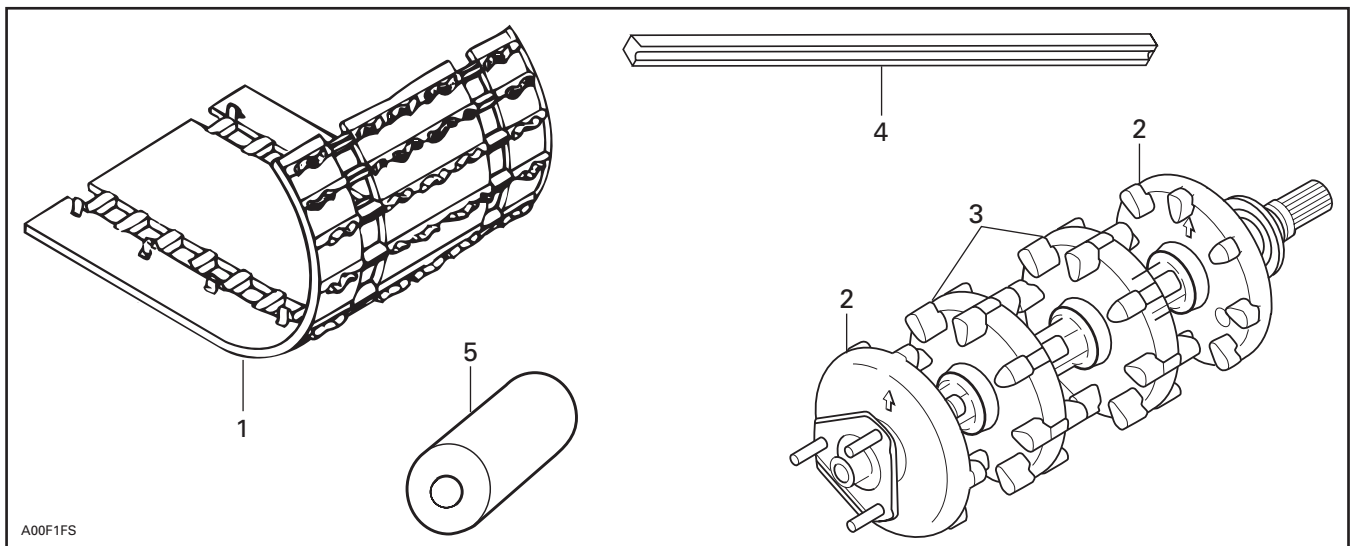

- 1. Track
- 2. Half-Sprocket (9 teeth) (2)
- 3. Sprocket (9 teeth) (2)
- 4. Radiator Protector (2)
- 5. Plastic Bushing (2)

VEHICLE PREPARATION

NOTE: If additional information is required, refer to *Ski-Doo Shop Manual*, Section 07 for proper removal/installation procedures.

Raise rear of vehicle and block safely.

Remove rear suspension and track.

Discard track.

INSTALLATION

Change radiator protectors **no. 4** if needed.

S-2000 Series Only

Invert the direction of the rivets of the firewall. To perform that operation, drill existing rivets and replace them with other ones of the same type. New rivets must be placed in the opposite direction so that new track will not touch them.

All Models

If needed, modify drive axle. Remove sprockets and half-sprockets from drive axle and replace with new sprockets **no. 3** and new half-sprockets **no. 2**.

Refer to Shop Manual for sprockets change procedure.

Reinstall drive axle with new sprockets.

Install new track **no. 1**, paying close attention to the direction of rotation (arrows are engraved on track).

SC-10 Suspension (S-2000 and CK3 Frames)

Unscrew set screws from locking ring at each end of the top axle.

Remove locking rings and top idler wheels.

Remove spring ends from adjusting cams as follows:

Slightly turn adjusting cam to expose spring end. Use spring installer (P/N 529 005 000), remove spring end from adjusting cam to remove spring tension.

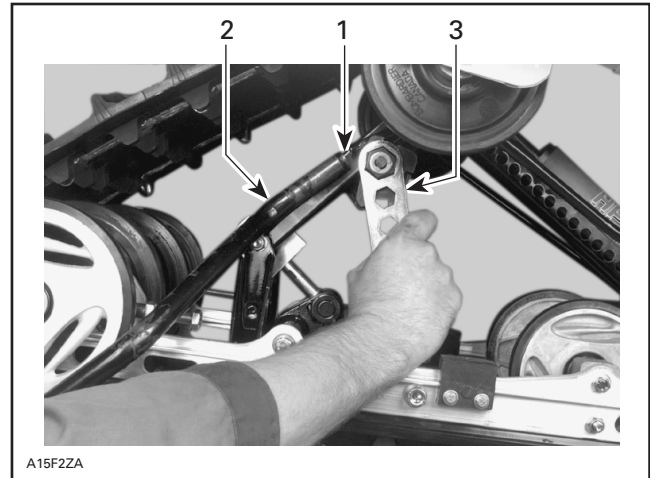

1. Spring end
2. Tool
3. Turn the cam

Remove existing plastic bushings (1 on each side). Install new bushings **no. 5**.

Reinstall spring end in cam using tool and adjust cam.

Reinstall idler wheels and locking rings.

Tighten set screws.

Pay attention to move the middle arm upper axle assembly down on the front bracket.

Drill hole **A** to 8.4 mm (21/64 in), refer to the following illustration.

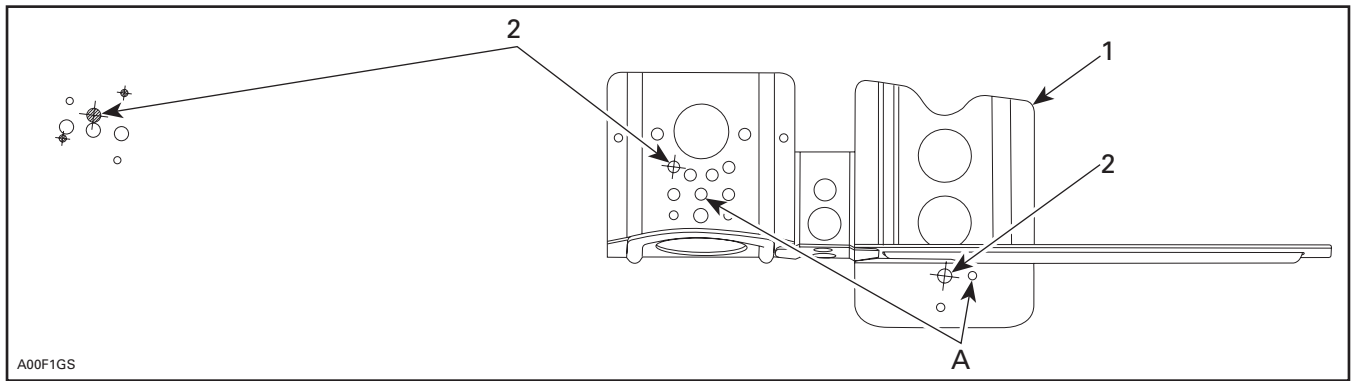

FRONT BRACKET RH SIDE SHOWN

- 1. Template (existing bracket)
- 2. Formerly used holes
- A. Drill these holes 8.4 mm (21/64 in)

Reinstall rear suspension in tunnel.

▼ CAUTION

Never use the lower hole in the bracket to secure the rear suspension arm. Damage to the tunnel may occur.

SC-10 Suspension (ZX Frame)

Perform the same disassembly as S-2000 and CK3 Series. For reinstallation:
 Drill hole **A** to 8.4 mm (21/64 in), refer to the following illustration. Use template on next sheet to drill bracket to the right place.

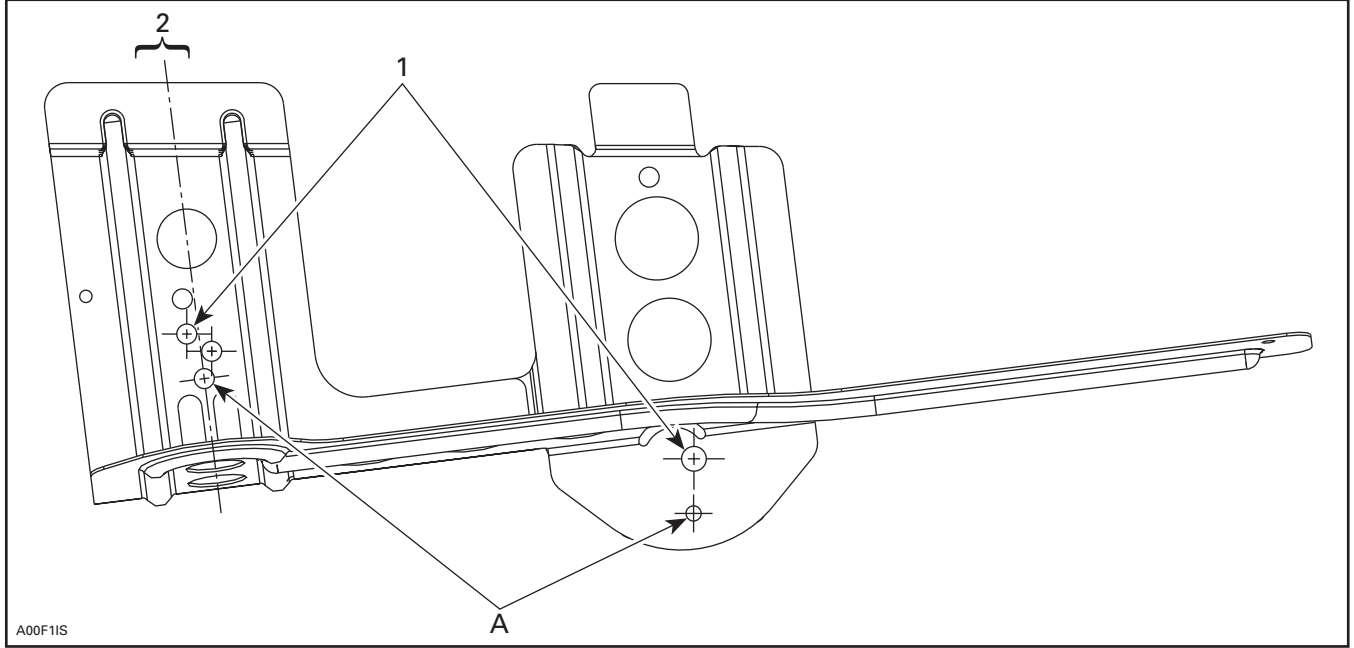

FRONT BRACKET RH SIDE SHOWN

- 1. Standard holes
- 2. Cut and install template on next sheet over this section of the bracket
- A. Drill these holes 8.4 mm (21/64 in)

Reinstall rear suspension in tunnel.

Check for proper operation of new track. If needed, preform track adjustment according to Shop Manual.

THIS PAGE IS
PURPOSELY BLANK

TEMPLATE

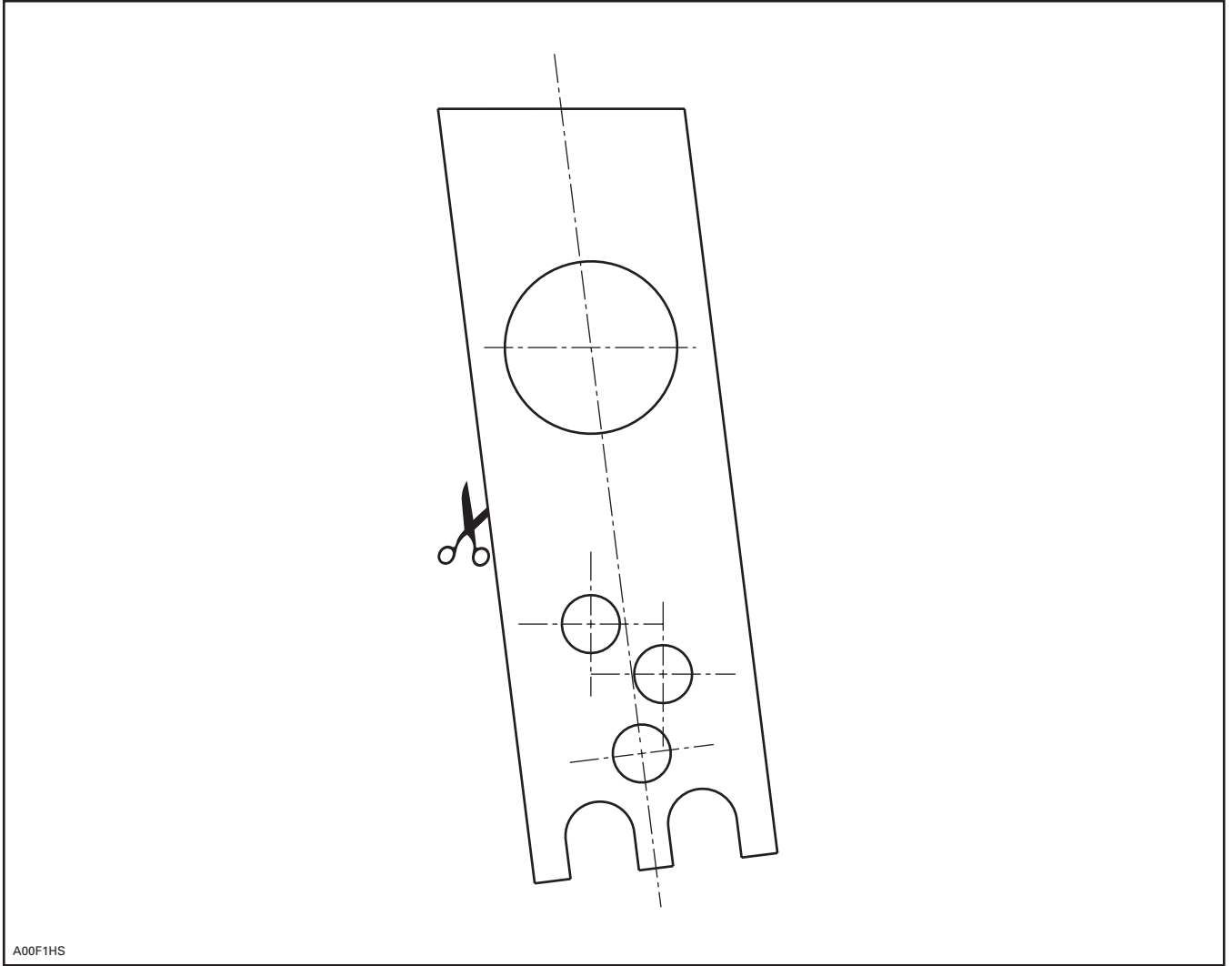

A00F1HS

861 770 600

1.	504 151 820	Track	Chenille
2.	415 117 700	Half-Sprocket (9 teeth) (2)	Demi-barbotin (9 dents) (2)
3.	415 117 600	Sprocket (9 teeth) (2)	Barbotin (9 dents) (2)
4.	415 012 300	Radiator Protector (2)	Protecteur de radiateur (2)
5.	572 086 100	Plastic Bushing (2)	Douille de plastique (2)