



MIRROR KIT
(P/N 861 771 400)

◆ **WARNING**

For safety reasons, this kit must be installed by an authorized Bombardier snowmobile dealer. Should removal of a locking device be required when undergoing disassembly/assembly, always replace with a new one. This instruction sheet should be given to the purchaser. This kit is designed for specific applicable models only. It is not recommended for units other than those for which it was sold.

NOTE: Installation time is approximately 0.5 hour.

PARTS TO BE INSTALLED

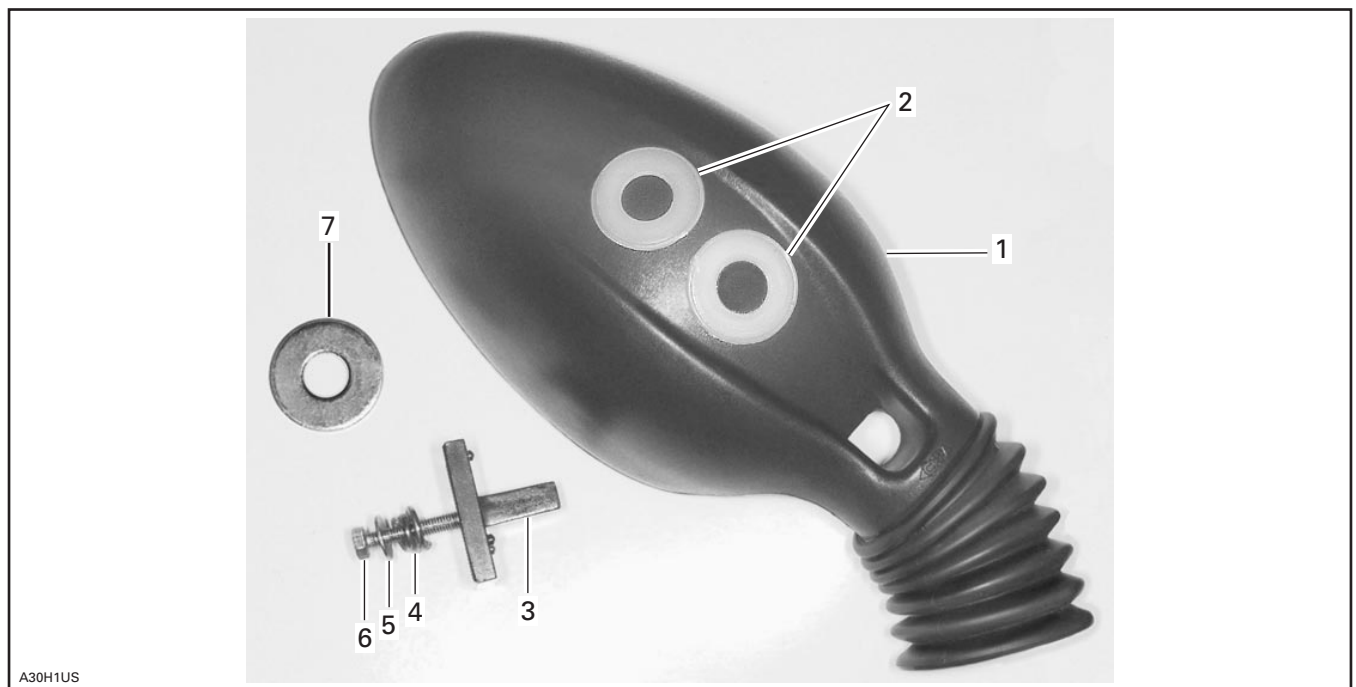

MIRROR ASSEMBLY, CONSISTING OF:

1. Mirror
2. Nylon Washer (2)
3. Anchor Block
4. Spring
5. Flat Washer (small)
6. Screw
7. Flat Washer (large)

INSTRUCTIONS

NOTE: This mirror kit to be used as a replacement kit on CK3 series with mirrors already on as well as new installation kit on CK3 and ZX Series.

CK3 Series (replacement mirror)

Remove existing mirror.

Clean surface underneath mirror.

Insert small flat washer **no. 5** and spring **no. 4** in screw **no. 6** and then screw in anchor block **no. 3**.

Insert anchor block from underneath. When and if needed, cut foam to allow perfect seating of anchor block onto hood inside surface.

From outside, align large flat washer **no. 7**, both nylon washers **no. 2** and mirror **no. 1**.

Tighten screw into mirror just enough to secure all assembly together and permit mirror adjustment, making sure mirror is perfectly centered in hole.

Complete tightening to 10 to 12 N•m (7.38 to 8.85 lbf•in).

Installation is now complete.

Repeat procedure for other side (if such is the case).

CK3 Series (new installation)

Using supplied template, locate and punch center of hole.

With a 12 mm (15/32 in) hole saw or unibit, drill hole through hood.

Proceed with mirror installation as described above.

Repeat procedure for other side (if such is the case), using other supplied template.

ZX Series (new installation)

Using supplied template, locate and punch center of hole.

With a 12 mm (15/32 in) hole saw or unibit, drill hole through hood.

Cut foam underneath to allow perfect seating of anchor block onto hood inside surface.

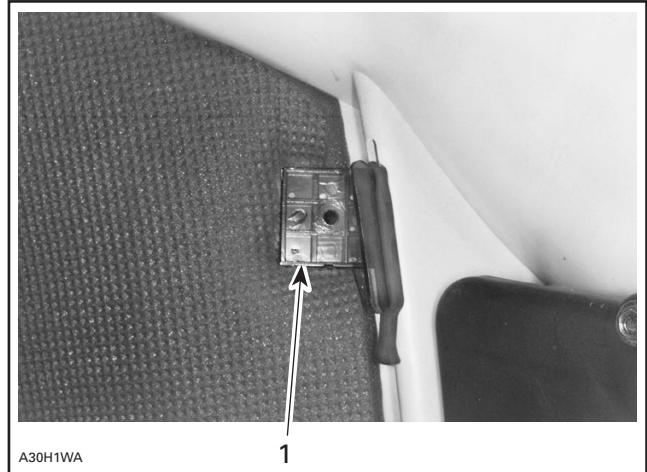

FOAM REMOVED

1. Anchor block in place

Proceed with mirror installation as described above.

Repeat procedure for other side (if such is the case), using other supplied template.



LEFT SIDE FINAL VIEW (ZX SERIES)

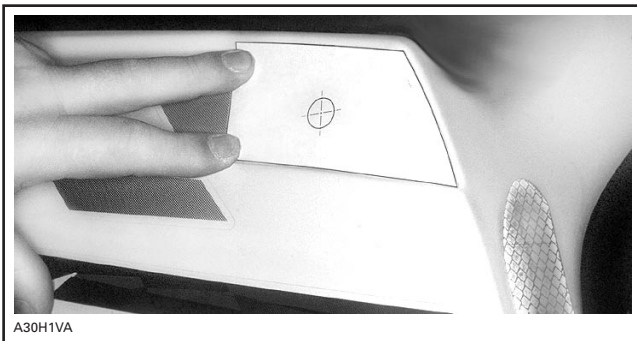

LEFT SIDE TEMPLATE IN PLACE

CK3 SERIES

RIGHT SIDE

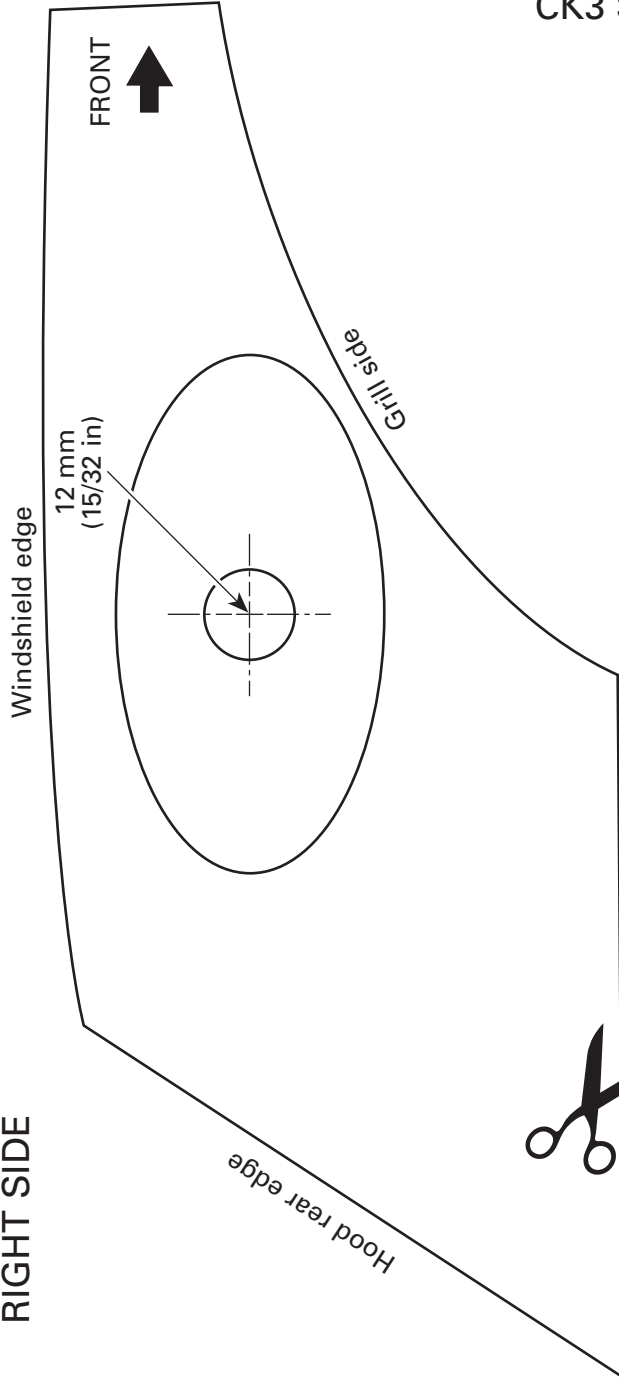

LEFT SIDE

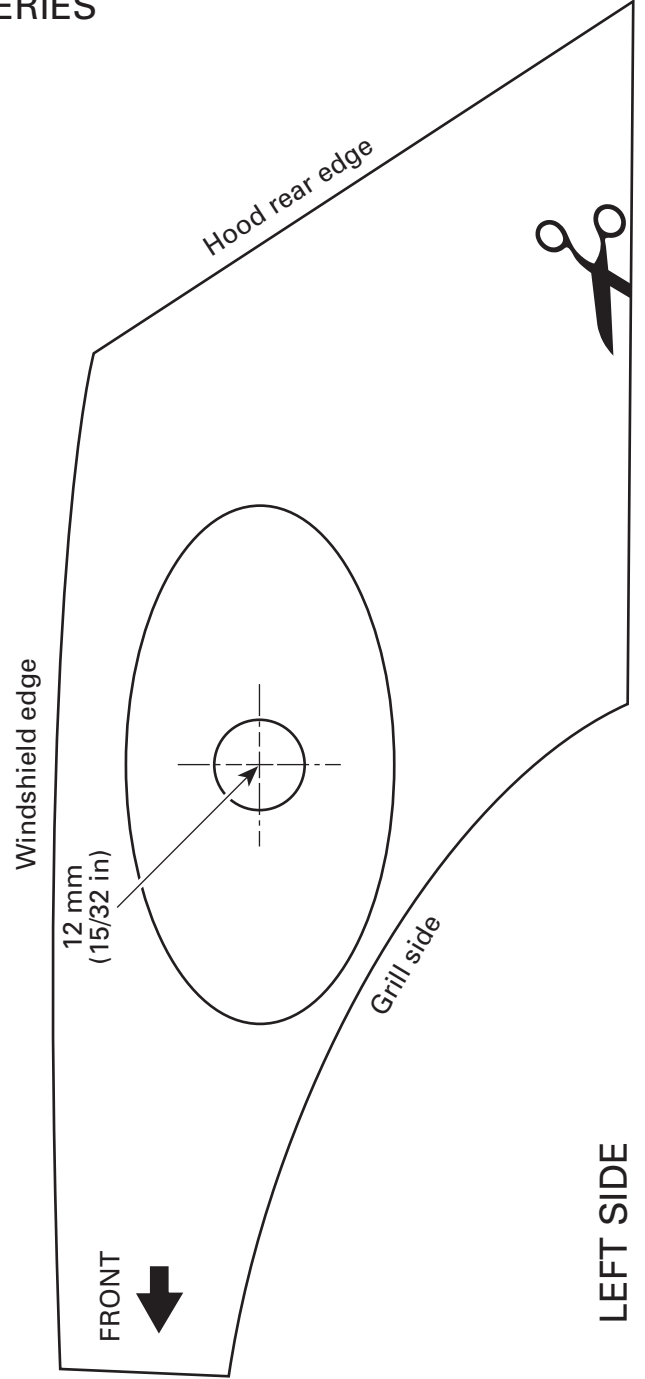

A30H1YS

THIS PAGE IS PURPOSELY BLANK

ZX SERIES

LEFT SIDE

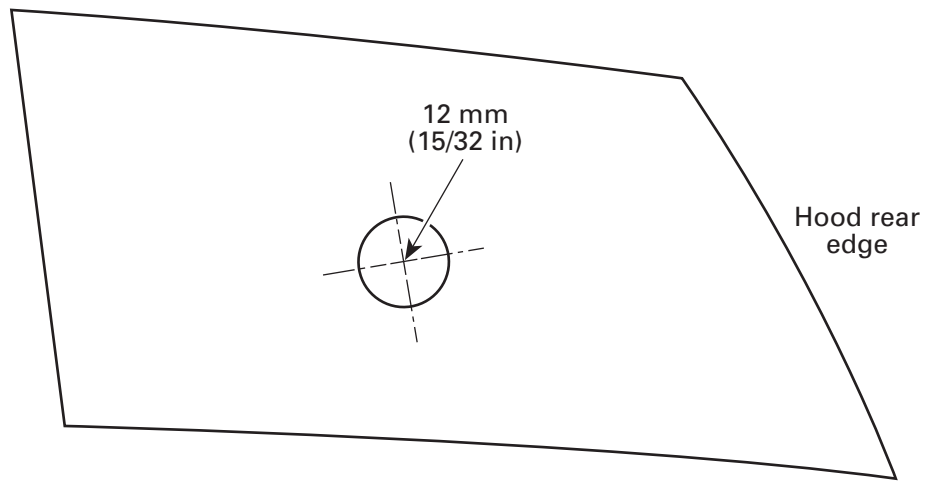

RIGHT SIDE

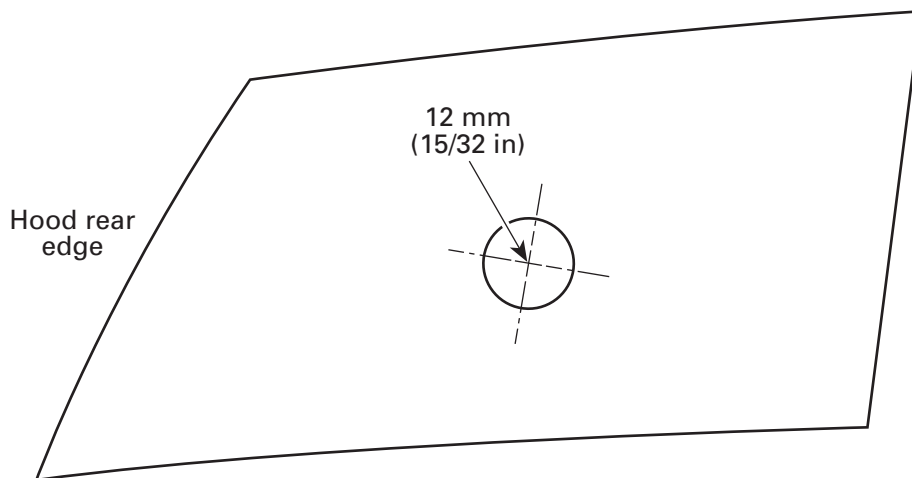

A30H1ZS

861 771 400

—	517 302 368	Mirror Assembly, consisting of:	Miroir (complet) comprend:
1.		Mirror	Miroir
2.		Nylon Washer (2)	Rondelle de nylon (2)
3.		Anchor Block	Bloc d'ancrage
4.		Spring	Ressort
5.		Flat Washer (small)	Rondelle plate (petite)
6.		Screw	Vis
7.		Flat Washer (large)	Rondelle plate (grande)