



**ADJUSTABLE BACKREST KIT  
(P/N 860 701 900)**

**◆ WARNING**

For safety reasons, this kit must be installed by an authorized Bombardier snowmobile dealer. Should removal of a locking device be required when undergoing disassembly/assembly, always replace with a new one. This instruction sheet should be given to the purchaser. This kit is designed for specific applicable models only. It is not recommended for units other than those for which it was sold.

NOTE: Installation time is approximately 1.0 hour.

**PARTS TO BE INSTALLED**

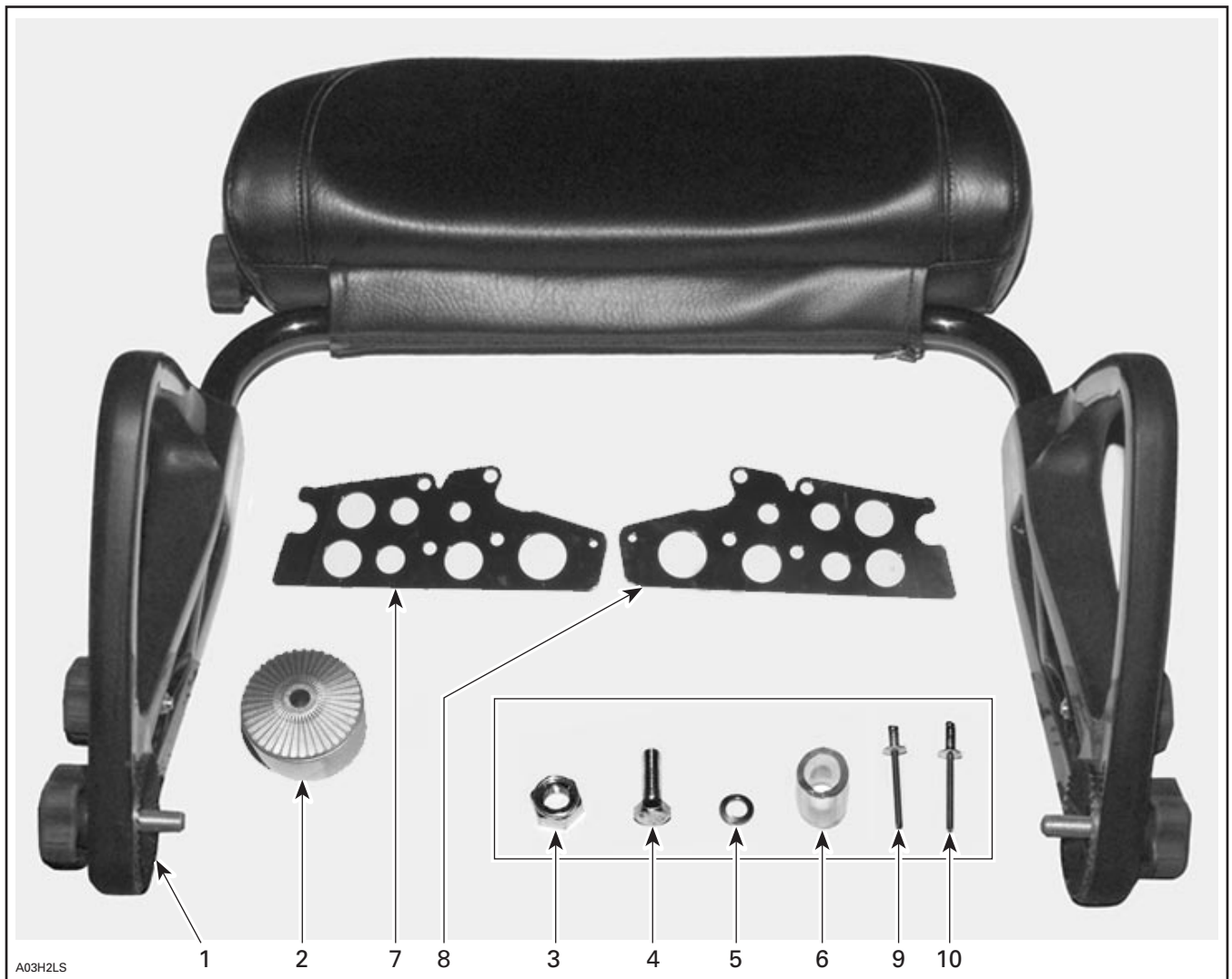

- 1. Backrest Ass'y
- 2. Geared Pivot (40 teeth) (2)
- 3. Hexagonal Self-Locking Nut M12 (2)
- 4. Hexagonal Screw M8 X 25 (8)
- 5. Helicoidal Lock Washer M8 (8)

- 6. Hose (2)
- 7. RH Bracket
- 8. LH Bracket
- 9. Rivet (short) (6)
- 10. Rivet (long) (4)

## Vehicle Preparation

Free suspension from rear section of tunnel.

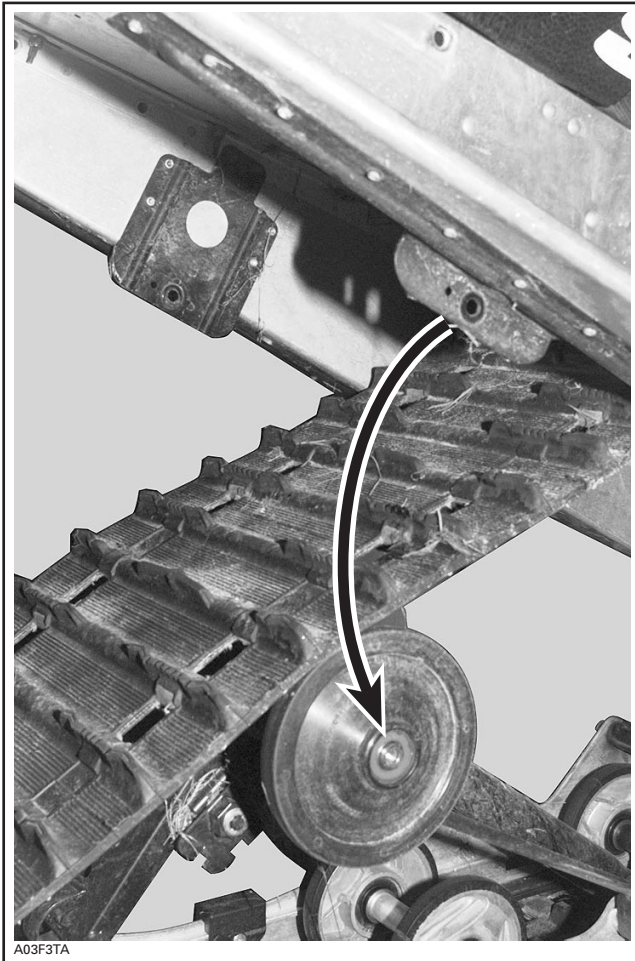

Unscrew bolts to free rear suspension

Lift rear of vehicle and block it safely.

**NOTE:** If vehicle is equipped with a fixed seat backrest, remove both backrest and Z-plates.

Drill a 8 mm (5/16 in) hole in the tunnel. Position hole as seen on next photo.

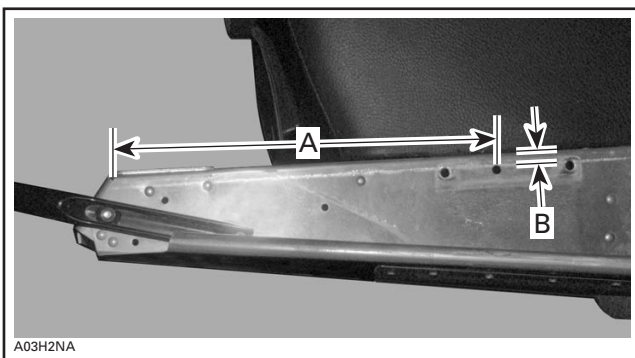

A. 350 mm (13-3/4 in) from end of tunnel  
B. 15 mm (5/8 in) from top of tunnel

**NOTE:** This hole might already be drilled on tunnel reinforcement.

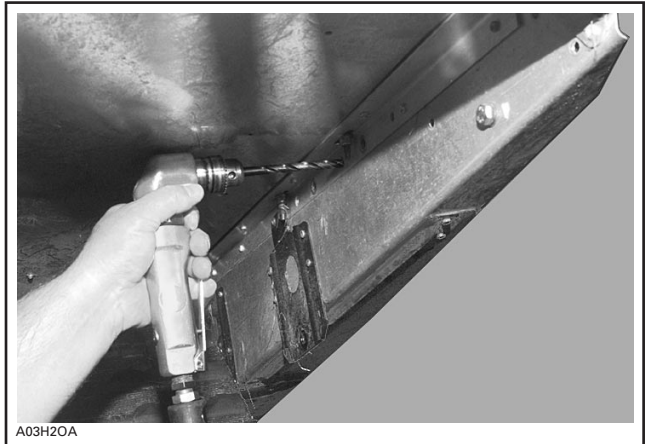

If the hole is done on tunnel reinforcement, use it as template to drill through tunnel

Cut template on last page and use it to punch 5 mm (13/64 in) holes on brackets no. 7 and no. 8.

Use screw no. 4 and geared pivot no. 2 to position and temporarily secure bracket no. 7 or no. 8 in place. Make sure rear upper side of bracket is parallel to tunnel reinforcement.

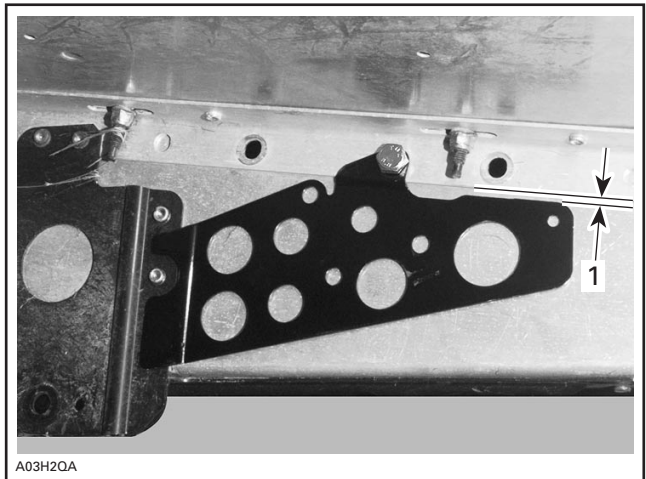

1. Make sure this side is parallel to tunnel.

Drill tunnel through little hole on rear side of bracket using a 5 mm (13/64 in) drill. Secure with rivet no. 9.

Drill the other rearmost hole (through bracket and tunnel) and secure with rivet **no. 9**.



*Rivet bracket from outside tunnel*

Next, drill center hole and secure with rivet **no. 9**.  
Last, drill the two holes in front through bracket **no. 7** or **no. 8**, suspension bracket and tunnel, then secure with rivets **no. 10**.

**NOTE:** Follow that sequence to ensure proper positioning of brackets.

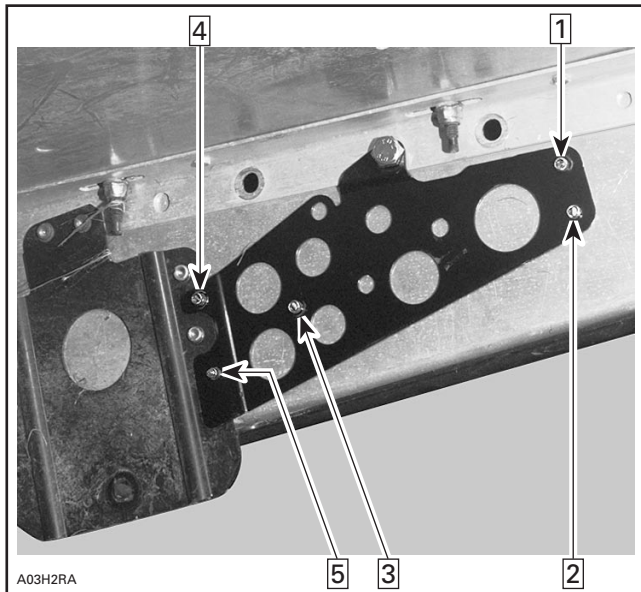

*Riveting sequence*

Remove geared pivot and punch the three 8 mm (5/16 in) holes.

Drill tunnel through holes using a 8 mm (5/16 in) drill.

Insert self-locking nut **no. 3** into geared pivot center hole. Set it in place using hose **no. 6**.

Install geared pivot with screws **no. 4** and lock washers **no. 5**.

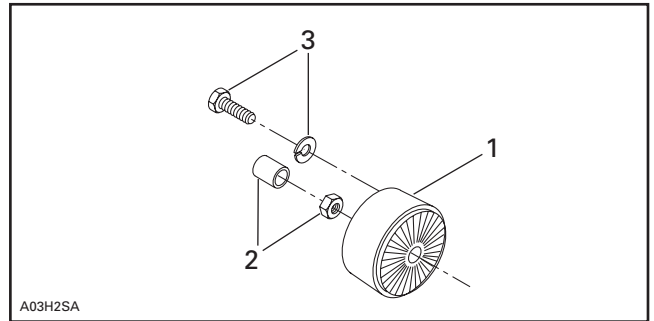

1. Geared Pivot
2. Insert self-locking screw and hose into geared pivot
3. Secure with screws and lock washers

Repeat procedure for the other side bracket and geared pivot installation.

Re-install rear suspension.

### Backrest Installation

Place backrest **no. 1** in place, adjust it to the preferred angle and height using the plastic knobs (see next photos) to fix it in place.

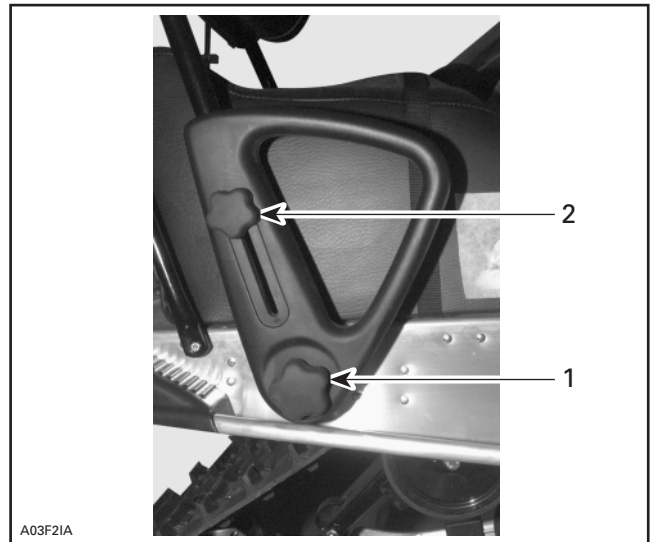

1. Backrest angle knob
2. Backrest height knob

**NOTE:** Use flat washers to help tighten backrest lower knob, as shown below.

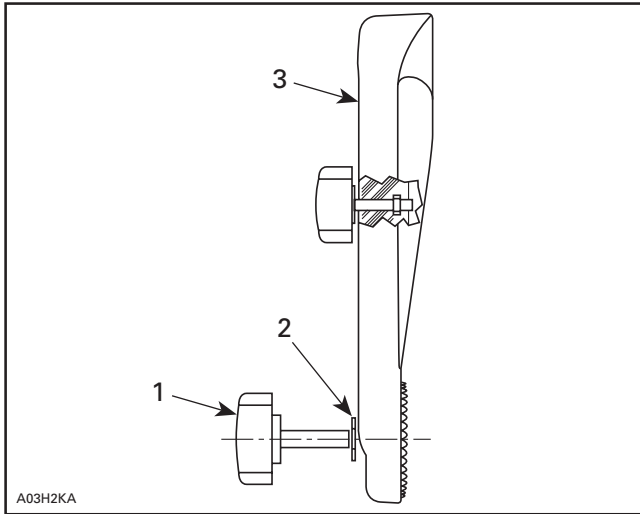

1. Backrest angle knob
2. Flat washer
3. Backrest arm

Adjust the cushion angle using the upper knob.

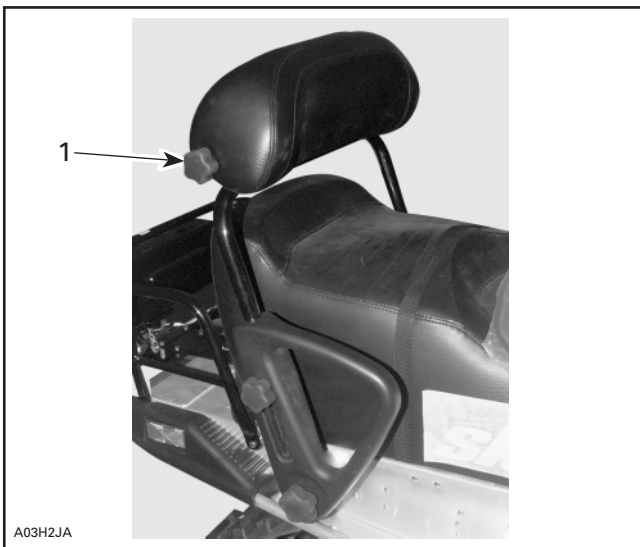

**INSTALLED BACKREST**

1. Backrest cushion angle knob

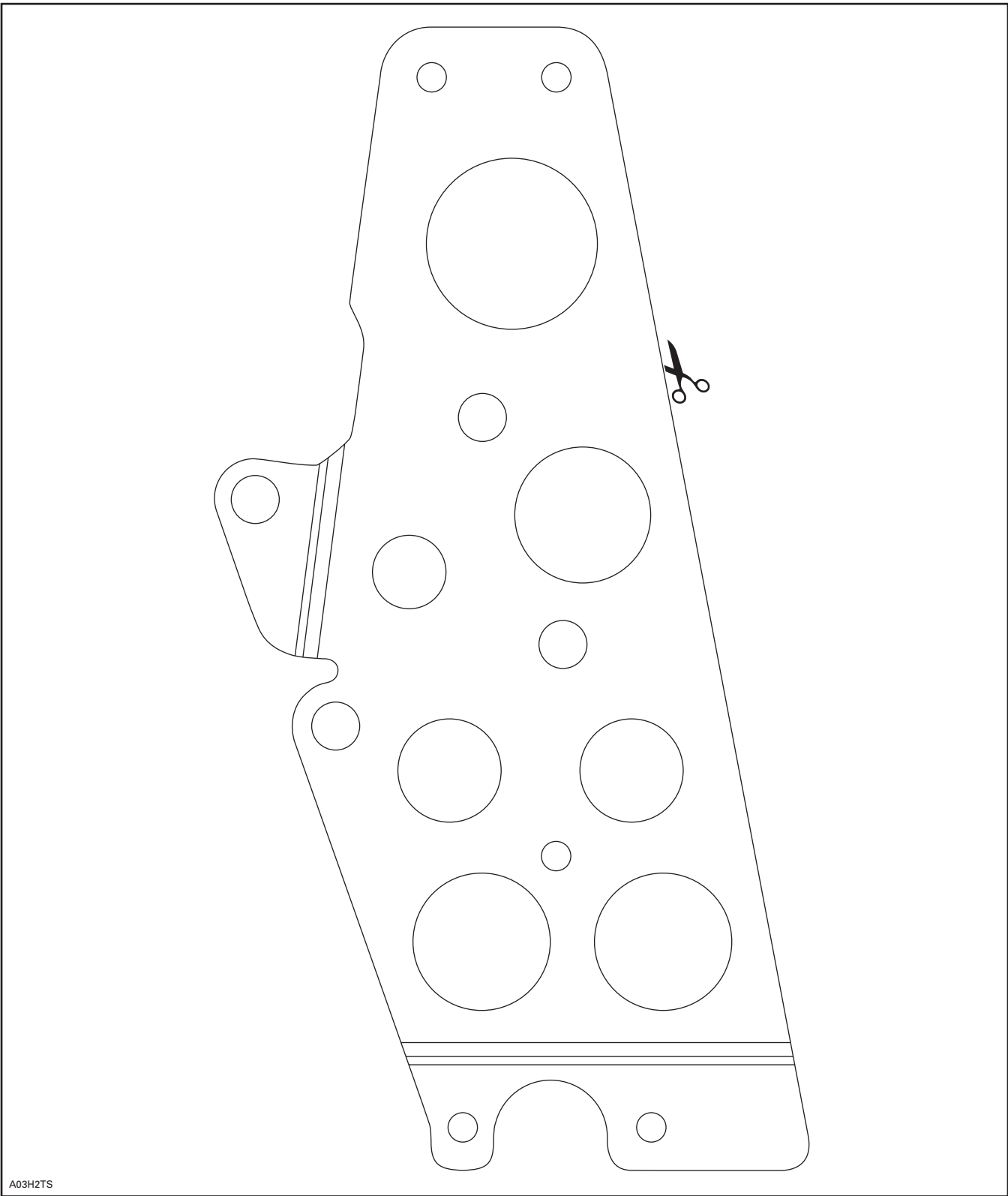

A03H2TS

## 860 701 900

1.	510 003 527	Backrest Ass'y	Dossier (complet)
2.	510 003 543	Geared Pivot (40 teeth) (2)	Pivot à engrenage (40 dents) (2)
3.	233 422 423	Hexagonal Self-Locking Nut M12 (2)	Écrou autobloquant hexagonal M12 (2)
4.	207 182 544	Hexagonal Screw M8 X 25 (8)	Vis hexagonale M8 X 25 (8)
5.	234 181 601	Helicoidal Lock Washer M8 (8)	Rondelle-frein hélicoïdale M8 (8)
6.	510 003 628	Hose (2)	Boyau (2)
7.	518 321 702	RH Bracket	Support de droite
8.	518 321 703	LH Bracket	Support de gauche
9.	390 402 400	Rivet (short) (6)	Rivet (court) (6)
10.	390 402 200	Rivet (long) (4)	Rivet (long) (4)