



**ACM SUSPENSION KIT
(P/N 860 501 800)**

◆ WARNING

For safety reasons, this kit must be installed by an authorized Bombardier snowmobile dealer. Should removal of a locking device be required when undergoing disassembly/assembly, always replace with a new one. This instruction sheet should be given to the purchaser. This kit is designed for specific applicable models only. It is not recommended for units other than those for which it was sold.

NOTE: Installation time is approximately 0.5 hour.

PARTS TO BE INSTALLED

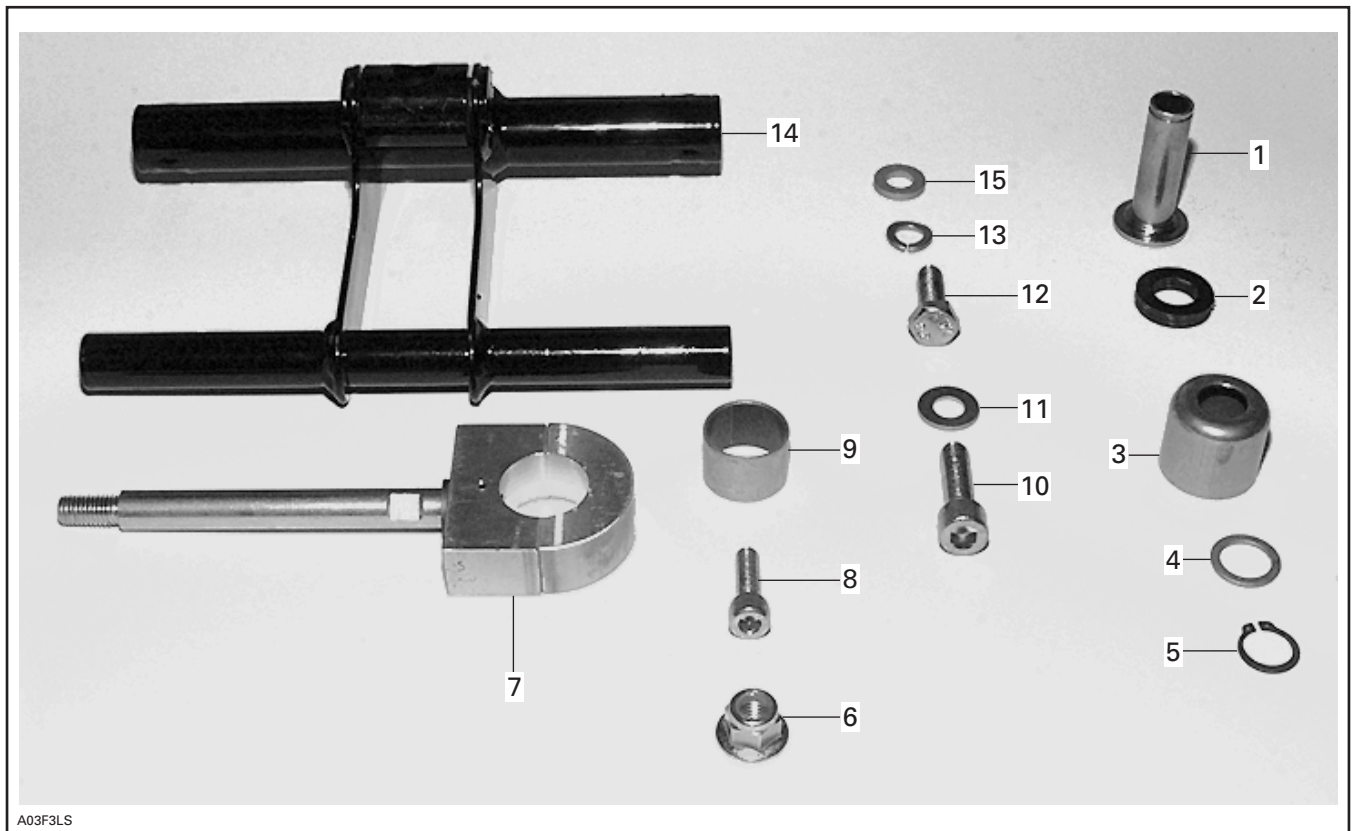

A03F3LS

- | | |
|----------------------------|----------------------------------|
| 1. Welded Bushing | 9. Cushion |
| 2. Rubber Stopper (3) | 10. Allen Screw M10 x 35 (2) |
| 3. Cup | 11. Flat Washer M10 (2) |
| 4. Washer | 12. Hexagonal Screw M10 x 30 (2) |
| 5. Circlip | 13. Arched Lock Nut (4) |
| 6. Elastic Flanged Nut M10 | 14. Welded Bracket |
| 7. Pivot Block Ass'y | 15. Hardened Flat Washer (2) |
| 8. Allen Screw M8 x 30 | |

PROCEDURE

Bushing Assembling

Insert rubber stoppers **no. 2** in welded bushing **no. 1** and recover them with cup **no. 3**.

Introduce assembly in the welded bracket's hole and secure with washer **no. 4** and circlip **no. 5**.

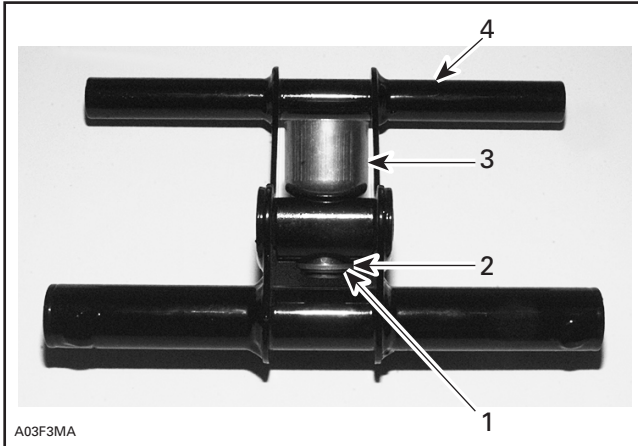

- 1. Circlip
- 2. Washer
- 3. Bushing Assembly
- 4. Welded Bracket

NOTE: Take care to install bushing assembly with cup on flat side of the bracket's hole.

Bracket Installation

Install bracket with the larger axle backward.

Secure rear axle with hexagonal screws **no. 12**, arched lock nuts **no. 13** and flat washers **no. 11**.

Position front axle in place and secure with Allen screws **no. 10**, arched lock nuts **no. 13** and hardened flat washers **no. 15**.

▼ CAUTION

Loctite 242 or Loctite 243 must be applied on threads for proper assembly.

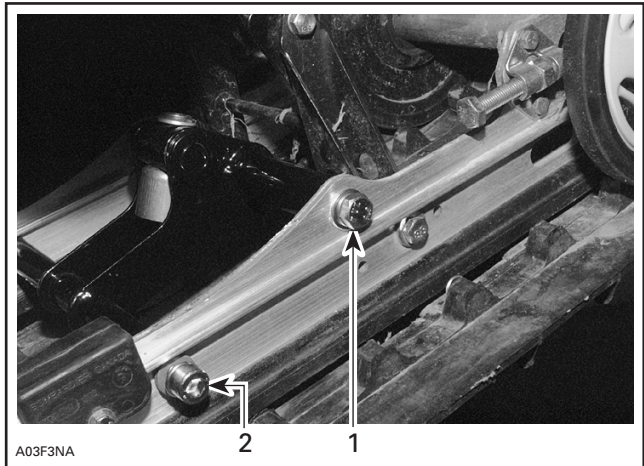

WELDED BRACKET INSTALLED

- 1. Rear axle secured with hexagonal screws
- 2. Front axle secured with Allen screws

Pivot Installation

Split cushion **no. 9** and place it on the center of the axle of the rear suspension arm.

Unscrew head of pivot **no. 7** and slide shaft of pivot into the bushing assembly.

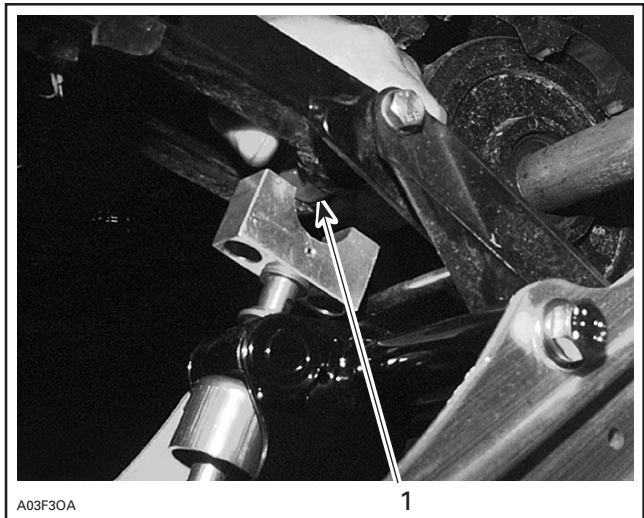

- 1. Cushion

Install pivot assembly around the cushion **no. 9**.
See photo below.

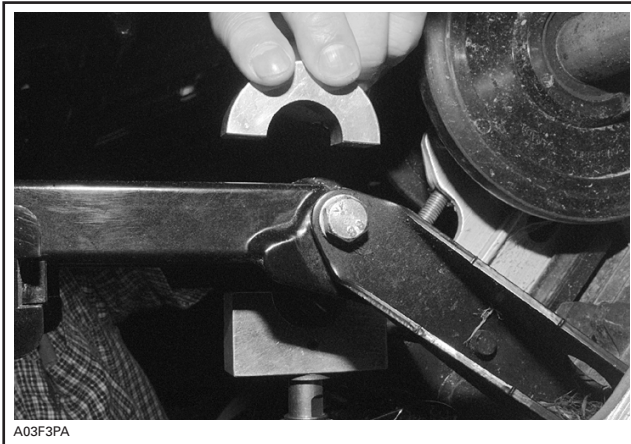

NOTE: Take care to align the dot marks on both parts of head of pivot.

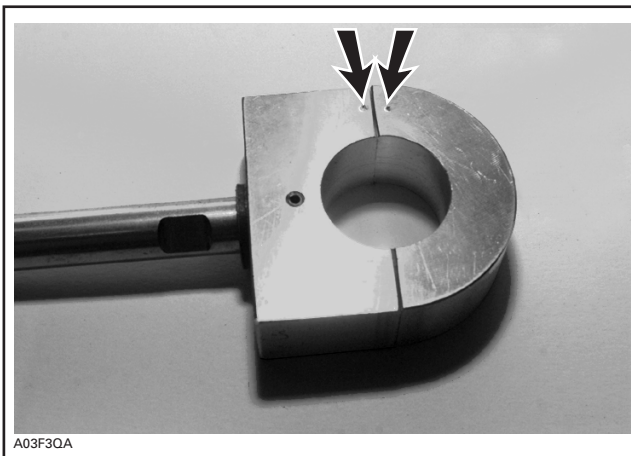

MARKS MUST BE BESIDE ONE EACH OTHER

Screw pivot head's Allen screw and complete with the other Allen screw **no. 8**.

Anchor shaft of pivot to welded bracket with elastic flanged nut **no. 6**.

860 501 800

1.	503 172 900	Welded Bushing	Douille soudée
2.	570 049 600	Rubber Stopper (3)	Butée de caoutchouc (3)
3.	503 103 600	Cup	Coupole
4.	503 183 400	Washer	Rondelle
5.	371 910 700	Circlip	Circlip
6.	233 201 414	Elastic Flanged Nut M10	Écrou d'arrêt élastique à épaulement M10
7.	503 189 044	Pivot Block Ass'y	Bloc de pivot (complet)
8.	205 083 044	Allen Screw M8 x 30	Vis Allen M8 x 30
9.	415 027 800	Cushion	Coussinet
10.	205 003 544	Allen Screw M10 x 35 (2)	Vis Allen M10 x 35 (2)
11.	224 001 211	Flat Washer M10 (2)	Rondelle plate M10 (2)
12.	207 103 044	Hexagonal Screw M10 x 30 (2)	Vis hexagonale M10 x 30 (2)
13.	224 701 188	Arched Lock Nut (4)	Écrou autobloquant cintré (4)
14.	503 188 969	Welded Bracket	Support soudé
15.	503 176 700	Hardened Flat Washer (2)	Rondelle plate trempée (2)