



**SKI STANCE WIDENING KIT (40 in)
(P/N 860 502 000)**

◆ WARNING

For safety reasons, this kit must be installed by an authorized Bombardier snowmobile dealer. Should removal of a locking device be required when undergoing disassembly/assembly, always replace with a new one. This instruction sheet should be given to the purchaser. This kit is designed for specific applicable models only. It is not recommended for units other than those for which it was sold.

NOTE: Installation time is approximately 2.0 hour.

PARTS TO BE INSTALLED

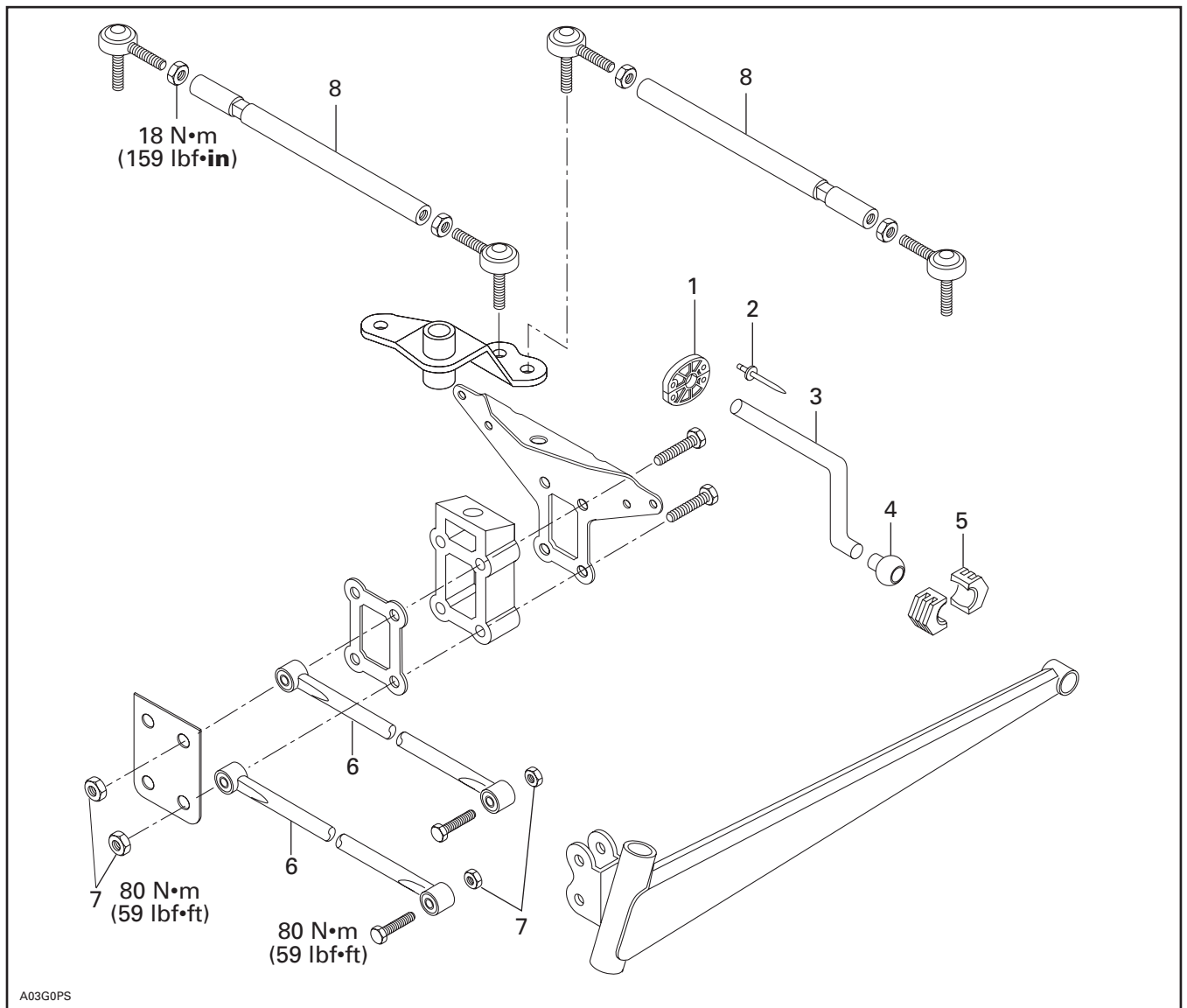

1. Half Bushing (4)
2. Rivet (8)
3. Stabilizer Bar
4. Ball Joint (2)

5. Sliding Block (4)
6. Suspension Arm Assy (4)
7. Elastic Flanged Nut M12 (8)
8. Tie Rod (2)

VEHICLE PREPARATION

Lift the front of the vehicle and support it with a stand.

Remove tuned pipe(s).

Unscrew tie-rods from the ball joints on both sides.

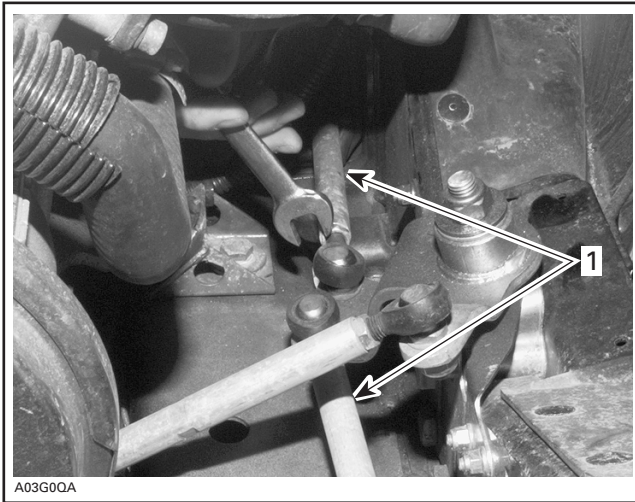

1. Unscrew tie-rods

Remove nuts and bolts from upper and lower control arms which are attached to the swing arms. Keep bolts and discard nuts.

Unscrew nuts holding upper and lower arms to link plate. Discard nuts.

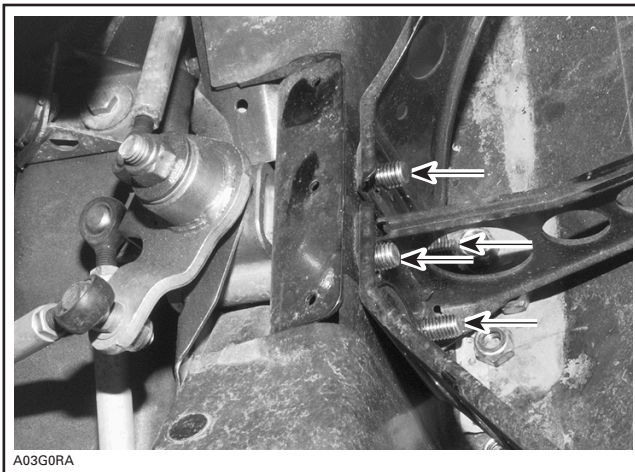

UNSCREW NUTS AND PUSH BOLTS TO FREE ARMS

Remove the plastic caps from the sides of the bottom pan. See next photo.

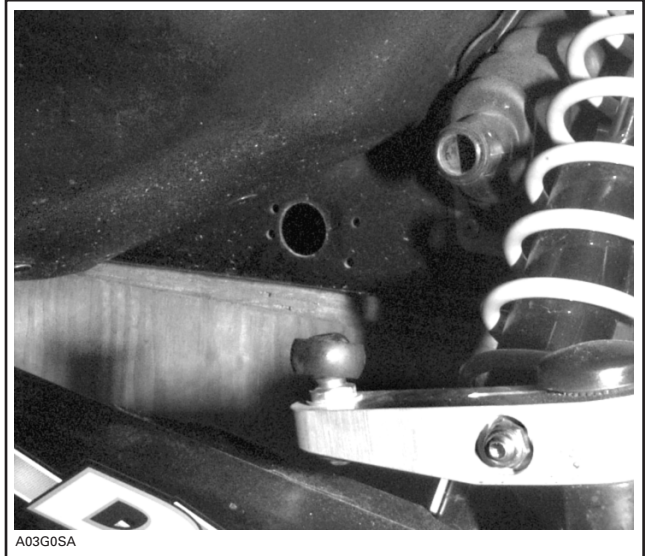

INSTALLATION

Remove existing upper and lower arms and install the new arms **no. 6** using M12 elastic nuts **no. 7** (inner side only, do not tighten yet).

Position arms with angle toward front as illustrated.

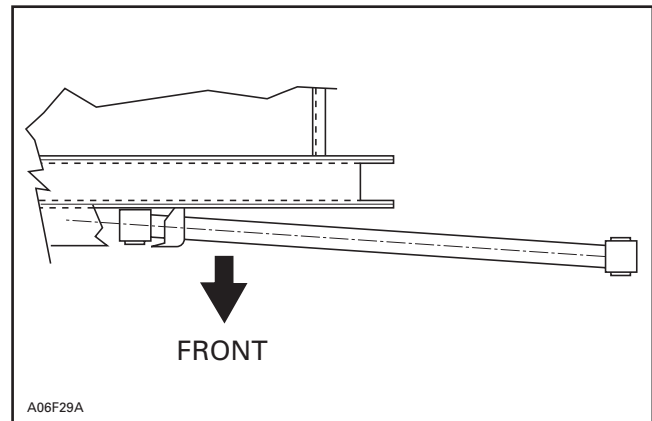

Install stabilizer bar **no. 3**.

Install half bushings **no. 1** using rivets **no. 2**.

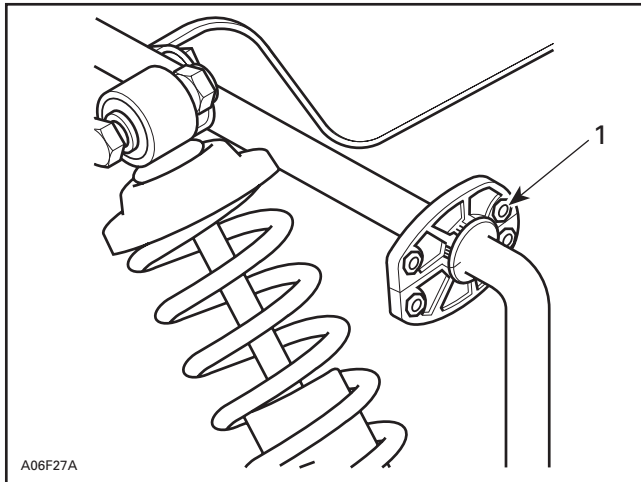

1. Rivets (4)

Unscrew swing arms from their pivots.

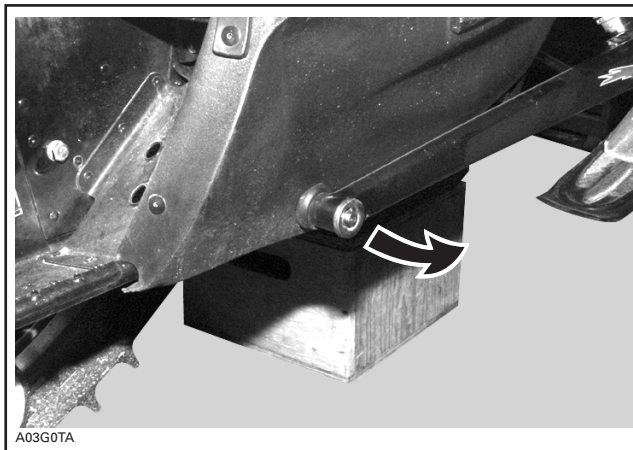

Install ball joints **no. 4** in the sliding blocks **no. 5**.

NOTE: Install sliding blocks both side at the same time.

Install sliding blocks into swing arms and apply low temperature grease (P/N 413 706 100). Refer to the following illustration.

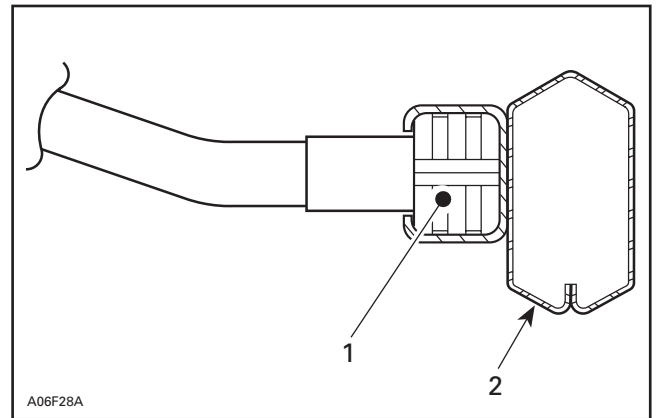

1. Sliding block
2. Swing arm

Coat swing arm pivots with synthetic grease (P/N 413 706 100) and reinstall swing arms on pivots.

Secure upper and lower control arms to swing arms with bolts. Secure with new elastic nuts **no. 7**. Tighten inner and outer bolts.

Install tie-rods **no. 8**. Make sure that clamping notch is outside.

ADJUSTMENTS

After assembly, perform a ski alignment and a ski leg camber adjustment.

Refer to the *Ski-Doo Shop Manual* for proper adjustment procedures.

Reinstall tuned pipe(s).

860 502 000

1.	572 077 600	Half Bushing (4)	Demi-douille (4)
2.	390 402 300	Rivet (8)	Rivet (8)
3.	506 127 200	Stabilizer Bar	Barre stabilisatrice
4.	506 127 300	Ball joint (2)	Joint à rotule (2)
5.	572 069 800	Sliding Block (4)	Bloc coulissant (4)
6.	580 649 600	Suspension Arm Assy (4)	Bras de suspension (complet) (4)
7.	228 521 045	Elastic Flanged Nut M12 (8)	Écrou d'arrêt élastique M12 (8)
8.	506 119 200	Tie Rod (2)	Barre d'accouplement (2)