



## ◆ WARNING

For safety reasons, this kit must be installed by an authorized Bombardier snowmobile dealer. Should removal of a locking device be required when undergoing disassembly/assembly, always replace with a new one. This instruction sheet should be given to the purchaser. This kit is designed for specific applicable models only. It is not recommended for vehicles other than those for which it was sold.

NOTE: Installation time is approximately 2.5 hours.

## PARTS TO BE INSTALLED

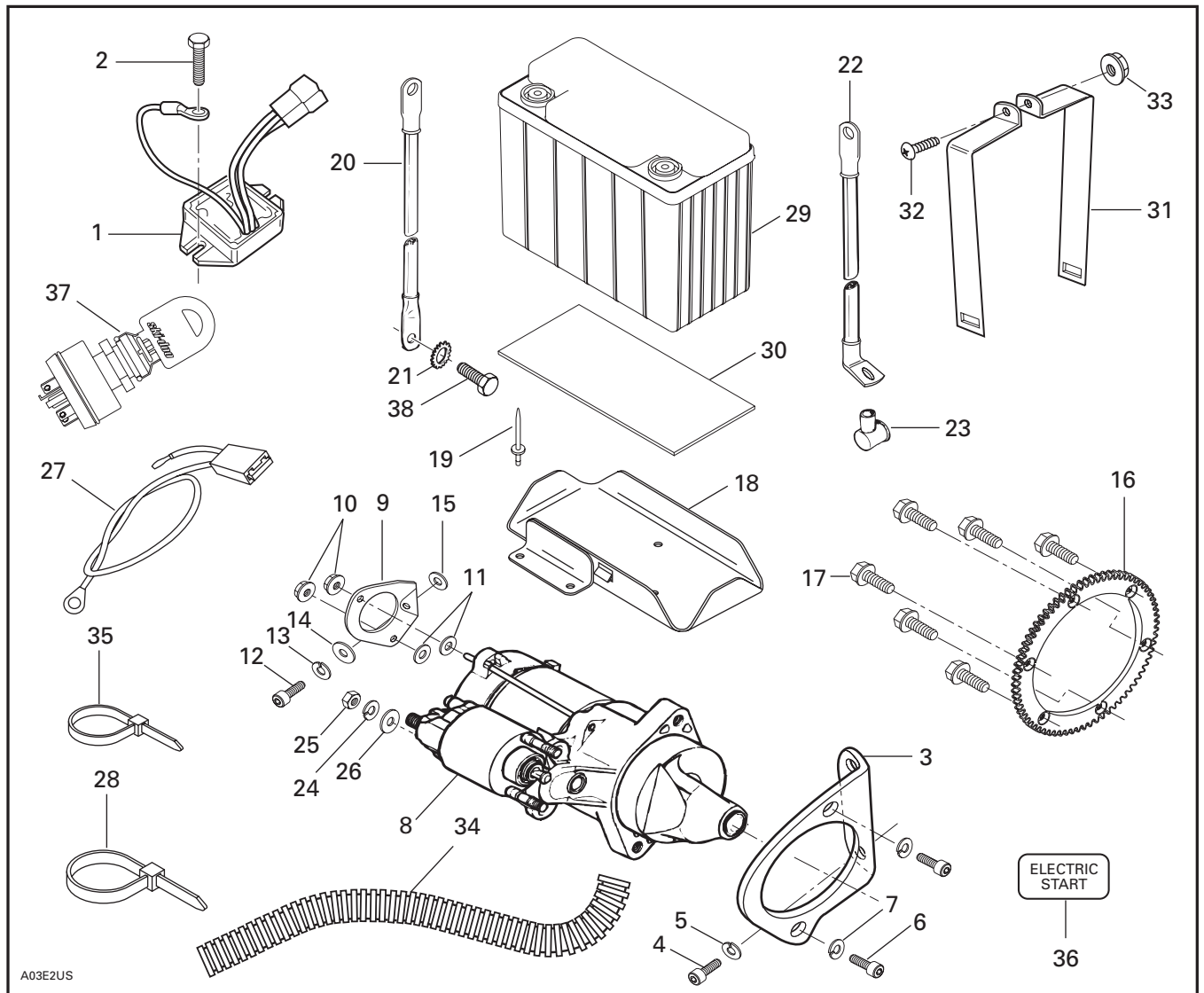

1. Regulator/Rectifier
2. Self-tapping Screw M6 x 16 (2)
3. Starter Support PTO
4. Socket Screw M8 x 20 (2)
5. Lock Washer M8 (2)
6. Socket Screw M8 x 25 (2)
7. Lock Washer M8 (2)
8. Starter
9. Starter Support MAG
10. Flanged Elastic Nut M5 (2)
11. Flat Washer (2)
12. Socket Screw M8 x 20
13. Lock Washer M8
14. Flat Washer M8
15. Hardened Washer (2)
16. Ring Gear
17. Self-tapping Screw M8 x 16 (6)
18. Battery Seat
19. Rivet (5)
20. Battery Ground Cable (BLACK)
21. Star Washer
22. Battery Positive Cable (RED)
23. Protector Cap (2)
24. Lock Washer M8
25. Hex. Nut M8
26. Flat Washer M8
27. Fuse Holder
28. Locking Tie (8)
29. Battery
30. Rubber Insulator
31. Steel Strip (2)
32. Hex. Screw M5 x 16
33. Hex. Flanged Nut M5
34. Protector
35. Locking Tie
36. Decal
37. Ignition Switch
38. Self-tapping Screw
39. Elbow Fitting (Not Illustrated)

## VEHICLE PREPARATION

### Battery

**NOTE:** Refer to the *Ski-Doo Shop Manual* for proper battery removal/installation procedure.

### **WARNING**

Never charge or boost battery while connected or installed in vehicle.

### Vehicle

Remove exhaust system, belt guard and drive belt.

Unfasten spark plug cables from fan housing. Unplug spark plug caps.

Unplug electronic box harness underneath carburetors by inserting a screwdriver in the connector tab and pull tab as illustrated.

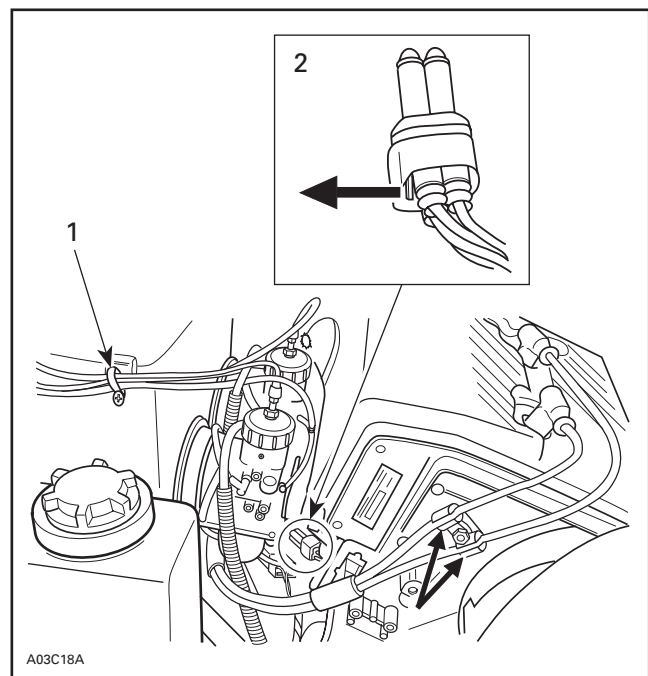

1. Plastic clip
2. CDI box harness connector

Open the plastic clip that is positioned on the air intake silencer. Insert a flat tip screw driver and turn as illustrated.

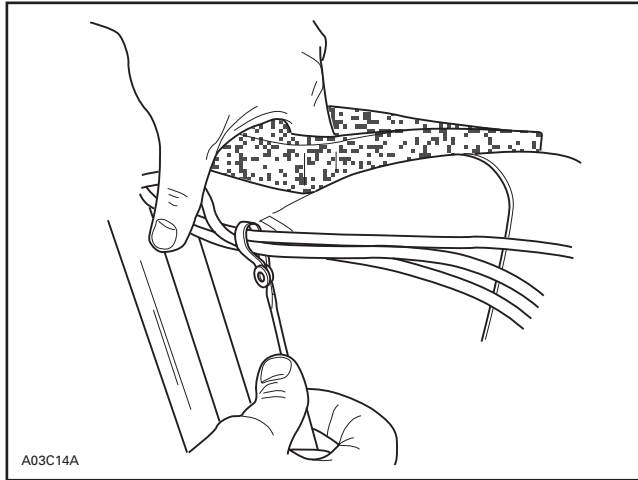

Remove the air intake silencer.

Empty fuel tank, change hose fitting with an elbow type fitting **no. 39** and outlet toward exterior, to clear battery corner.

## INSTALLATION

### Regulator/Rectifier

1. Remove original regulator/rectifier, located along RH side member of frame. Secure new regulator/rectifier **no. 1** using self tapping screws **no. 2**. Use 1 screw to connect the ground wire from regulator/rectifier as shown.

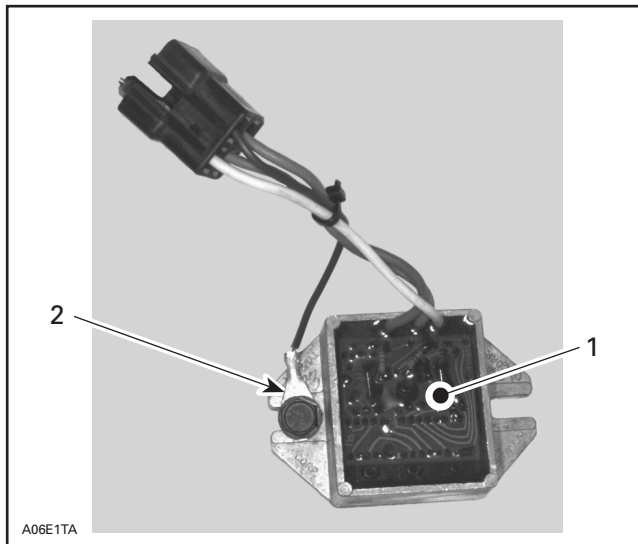

1. Regulator/rectifier
2. Connect ground wire here

2. Apply silicone dielectric grease (P/N 413 701 700) in the regulator/rectifier 4-connector housing as well as the vehicle harness 4-connector housing and plug them together.

### Ring Gear

Remove drive pulley. Refer to *Shop Manual* to perform drive pulley disassembly/assembly procedures and to proceed with pulley alignment.

Secure ring gear **no. 16** on inner half using 6 self tapping screws **no. 17**.

### ▼ CAUTION

Loctite 271 (red) must be applied on bolt threads to properly assemble the ring gear.

Torque screws to 27 N•m (20 lbf•ft) in a criss-cross sequence.

Do not reinstall drive pulley at this time.

### Ignition Switch

Cut locking tie and unplug switch connector housing from ignition switch.

Install new ignition switch **no. 37**.

Insert the shortest wire of the fuse holder **no. 27** inside switch connector housing.

Insert connector in position number 7 on the switch-connector housing.

Reposition connectors respecting the vehicle connector code as illustrated.

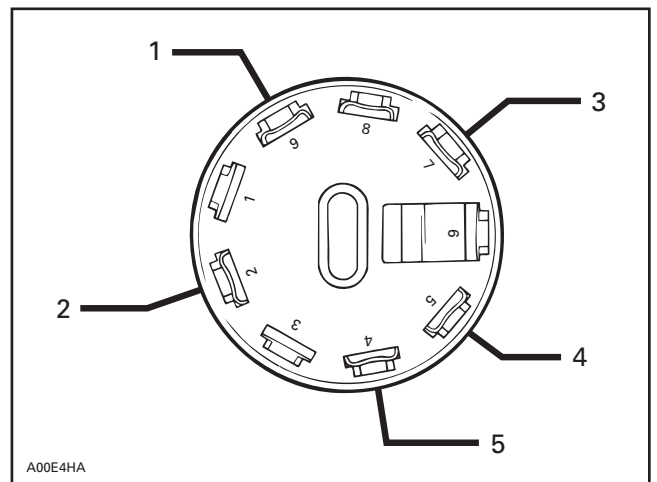

1. RED/GREEN wire to solenoid
2. BLACK/YELLOW
3. RED wire with fuse to battery
4. BLACK
5. RED/BLUE

Replug switch connector housing to ignition switch and secure wires with a locking tie **no. 28** as shown.



1. Locking tie

## Wire/Cable Connections and Routing

Ensure one connector of the RED battery cable no. 22 is straight and other connector is bent at 60°. Bend or straighten as required.

The straight connector will be connected to the solenoid.

Starting from battery location, route battery positive cable along vehicle harness to the starter location. See following illustrations.

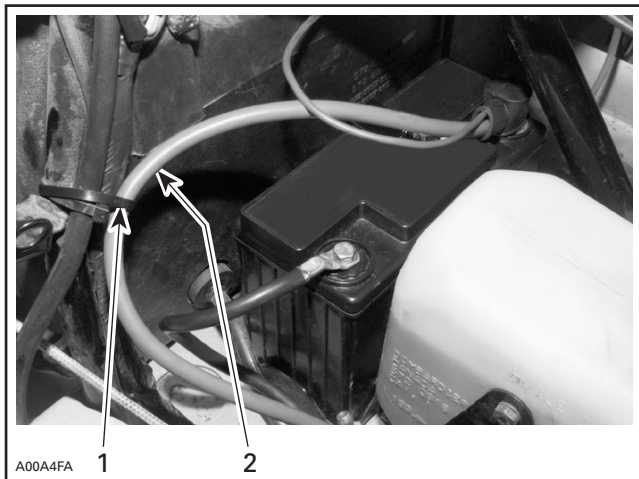

1. Secure with locking tie  
2. RED positive cable routing

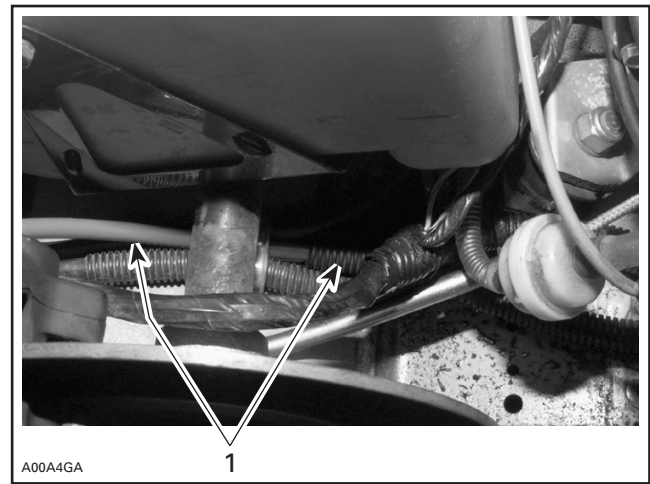

1. RED positive cable routing

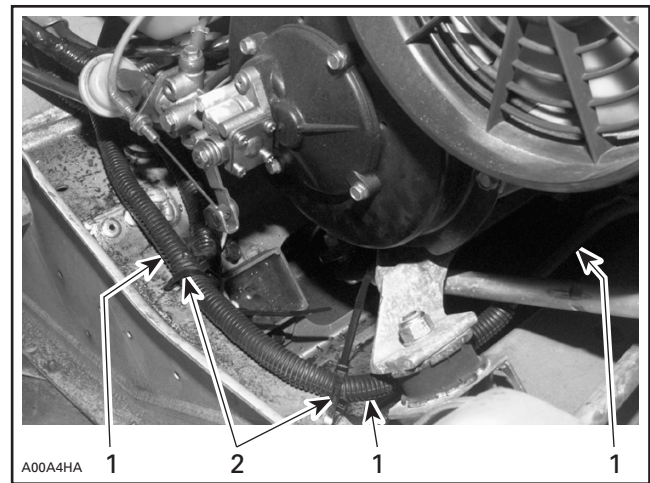

1. RED positive cable routing  
2. Secure with locking ties

**NOTE:** Route battery cables through free bracket underneath countershaft.

Connect battery BLACK ground cable no. 20 to side of fan housing using self-tapping screw no. 38 and star washer no. 21. Refer to next photo.

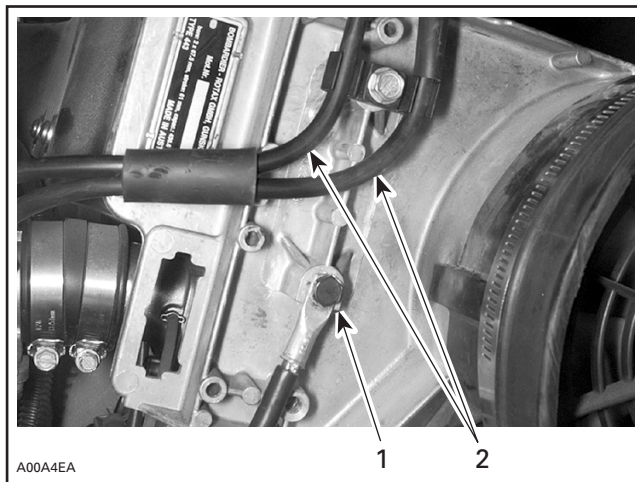

1. Connect battery ground cable here
2. Spark plug wires

## Electric Starter

### ▼ CAUTION

Apply Loctite 271 (red) on all fastener threads of starter supports.

Secure starter support **no. 3** (PTO side) to engine using socket screws **no. 4** and lock washers **no. 5**. Tighten firmly.

Mount electric starter **no. 8** on support. Secure bottom first and then the top using socket screws **no. 6** and lock washers **no. 7**.

Install washers **no. 11** over nuts of starter through bolts (MAG side).

Install starter support **no. 9** (MAG side) to starter and secure with flanged elastic nuts **no. 10**.

If necessary, install hardened washer(s) **no. 15** to fill the gap between the support and the engine. Secure support to the engine with washer **no. 14**, lock washer **no. 13** and screw **no. 12**.

Install cable protector **no. 34** then slide protector cap **no. 23** onto RED battery cable **no. 22**. Install RED cable on starter with washer **no. 26**, lock washer **no. 24** and nut **no. 25**. Bend connectors as required.

Cut the locking tie that is retaining the RED/GREEN wire to the wiring harness beneath engine.

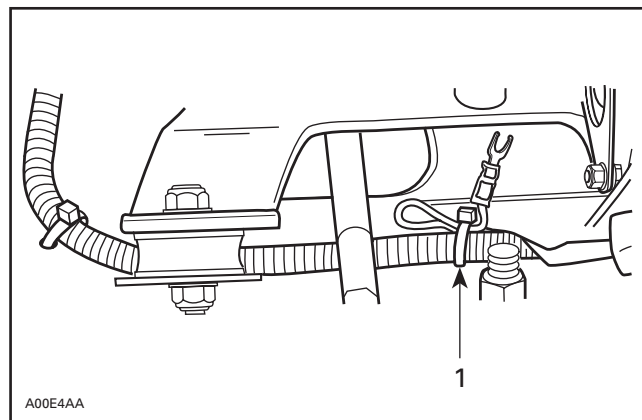

1. Cut locking tie

Connect RED/GREEN wire to the small post on solenoid. Position connector under lock washer.

Secure cables loosely to the rear bracket with a locking tie **no. 28**, as illustrated.

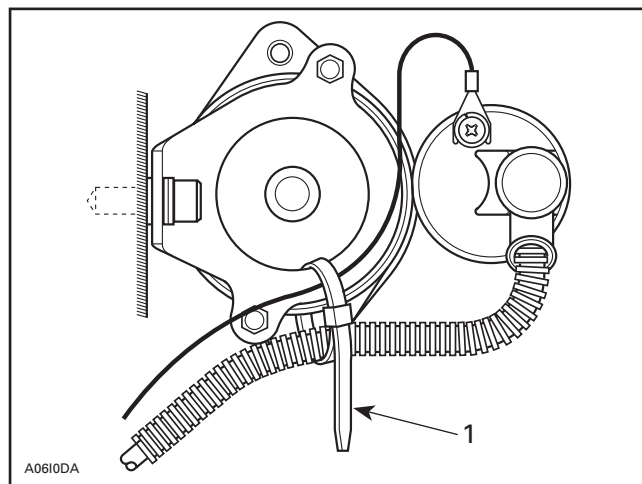

1. Tie loosely

Pull excess amount of cable from underneath engine.

## Battery and Rack

### ▼ CAUTION

Cover carburetor intakes with a clean rag during the following drilling operation.

Remove oil reservoir from its support.

Remove reservoir support (keep the bolts for reinstallation), then the plate underneath it by drilling out retaining rivets.

Install support in a vice to bend to proper angle, refer to following illustration.

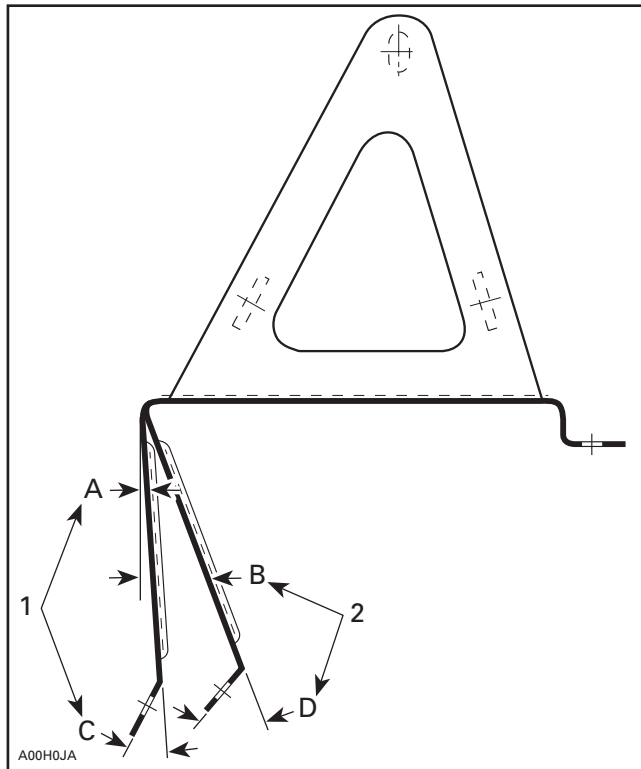

1. Original angles
2. New angles
- A. 4°
- B. 24°
- C. 31.6°
- D. 60°

Join battery seat **no. 18** to oil reservoir support using 2 rivets **no. 19**, making sure that support is mounted on top of battery seat.

Drill out battery vent fitting on body.

Install this assembly in place and secure, in same holes, by using previously removed oil reservoir support bolts.

At battery seat, use existing outer rivet hole as a first hole and drill two 5.2 mm (13/64 in) holes in body then secure with rivets **no. 19**.

Install rubber insulator **no. 30** and battery **no. 29** with positive post inside.

Secure battery in place with steel strips **no. 31**, using screw **no. 32** and flanged nut **no. 33**.

Insert protector cap **no. 23** onto red positive cable.

Connect battery RED positive cable and RED wire with fuse from ignition switch to battery post, upward angle, and tighten. Cover battery post with protector cap, then connect the BLACK ground cable and secure to battery post.

### ◆ WARNING

Always connect the battery cables exactly in the specified order. Connect RED positive cable first, then BLACK negative ground cable.

Fasten battery cables using a locking tie **no. 35**.

### ◆ WARNING

Ensure all terminals are properly crimped on wires/cables and that all connector housings are properly fastened. Keep wires away from any rotating, moving, heating or vibrating parts as well as from sharp edges. Use proper fastening devices as required.

## FINALIZING INSTALLATION

**NOTE:** Refer to the *Ski-Doo Shop Manual* for proper reinstallation procedure.

Reinstall oil reservoir in its support.

Reinstall drive pulley.

Check pulley alignment.

### ◆ WARNING

Drive pulley alignment must always be checked whenever pulleys have been removed, replaced or disassembled.

Reinstall remaining removed parts.

## Decal

Clean decal area with soapy water or isopropyl alcohol using a soft clean cloth and dry thoroughly.

### ▼ CAUTION

Do not apply isopropyl alcohol on decal.

Remove backing from decal.

Apply decal **no. 36** as shown.

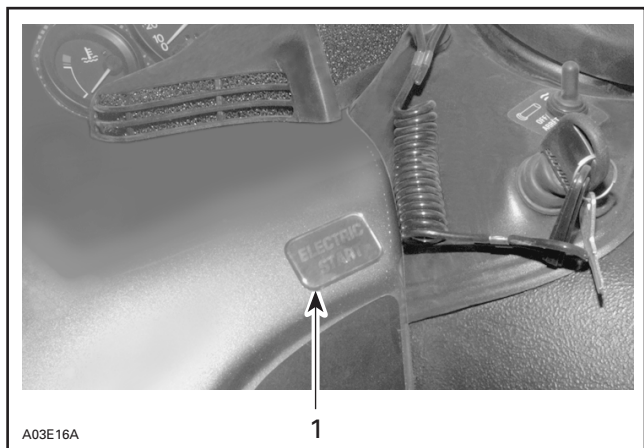

1. Decal

## 861 504 200

1.	515 163 900	Regulator/Rectifier	Régulateur/redresseur
2.	210 261 680	Self-tapping Screw M6 x 16 (2)	Vis autotaraudeuse M6 x 16 (2)
3.	420 951 692	Starter Support PTO Side	Support de démarreur (côté PDM)
4.	205 082 044	Socket Screw M8 X 20 (2)	Vis à tête creuse M8 x 20 (2)
5.	420 945 752	Lock Washer M8 (2)	Rondelle-frein M8 (2)
6.	205 082 544	Socket Screw M8 X 25 (2)	Vis à tête creuse M8 x 25 (2)
7.	234 181 401	Lock Washer M8 (2)	Rondelle-frein M8 (2)
8.	410 212 400	Starter	Démarreur
9.	420 951 702	Starter Support MAG Side	Support de démarreur (côté MAG)
10.	233 251 414	Flanged Elastic Nut M5 (2)	Écrou d'arrêt élastique à épaulement M5 (2)
11.	391 301 700	Flat Washer (2)	Rondelle plate (2)
12.	205 082 044	Socket Screw M8 X 20	Vis à tête creuse M8 x 20
13.	420 945 752	Lock Washer M8	Rondelle-frein M8
14.	234 081 410	Flat Washer M8	Rondelle plate M8
15.	503 007 900	Hardened Washer (2)	Rondelle trempée (2)
16.	415 043 100	Ring Gear	Couronne de lancement
17.	732 601 246	Self-tapping Screw M8 x 16 (6)	Vis autotaraudeuse M8 x 16 (6)
18.	517 301 700	Battery Seat	Support de batterie
19.	390 402 200	Rivet (5)	Rivet (5)
20.	515 175 287	Battery Ground Cable (BLACK)	Câble de masse de la batterie (NOIR)
21.	394 001 900	Star Washer	Rondelle en étoile
22.	515 175 288	Battery Positive Cable (RED)	Câble positif de la batterie (ROUGE)
23.	570 151 000	Protector Cap (2)	Capuchon de protection (2)
24.	420 945 752	Lock Washer M8	Rondelle-frein M8
25.	232 081 414	Hex. Nut M8	Écrou hexagonal M8
26.	234 081 410	Flat Washer M8	Rondelle plate M8
27.	515 157 300	Fuse Holder	Porte-fusible
28.	414 115 200	Locking Tie (8)	Attache (8)
29.	410 301 200	Battery	Batterie
30.	570 070 300	Rubber Insulator	Bande isolante de caoutchouc
31.	517 301 600	Steel Strip (2)	Bande d'acier (2)
32.	207 151 644	Hex. Screw M5 x 16	Vis à tête hexagonale M5 x 16
33.	233 251 414	Hex. Flanged Nut M5	Écrou hexagonal à épaulement M5
34.	414 627 300	Protector	Gaine de protection
35.	748 001 001	Locking Tie	Attache



## 861 504 200

36.	418 001 300	Decal	Autocollant
37.	410 111 300	Ignition Switch	Interrupteur d'allumage
38.	210 361 280	Self-tapping Screw	Vis autotaraudeuse
39.	414 580 600	Elbow Fitting (not illustrated)	Raccord coudé (non illustré)