



◆ **WARNING**

For safety reasons, this kit must be installed by an authorized Bombardier snowmobile dealer. Should removal of a locking device be required when undergoing disassembly/assembly, always replace with a new one. This instruction sheet should be given to the purchaser. This kit is designed for specific applicable models only. It is not recommended for vehicles other than those for which it was sold.

NOTE: Installation time is approximately 2.5 hours.

▼ **CAUTION**

Using this kit for application other than deep snow conditions will cause premature wear and possibly severe damage to the track.

PARTS TO BE INSTALLED

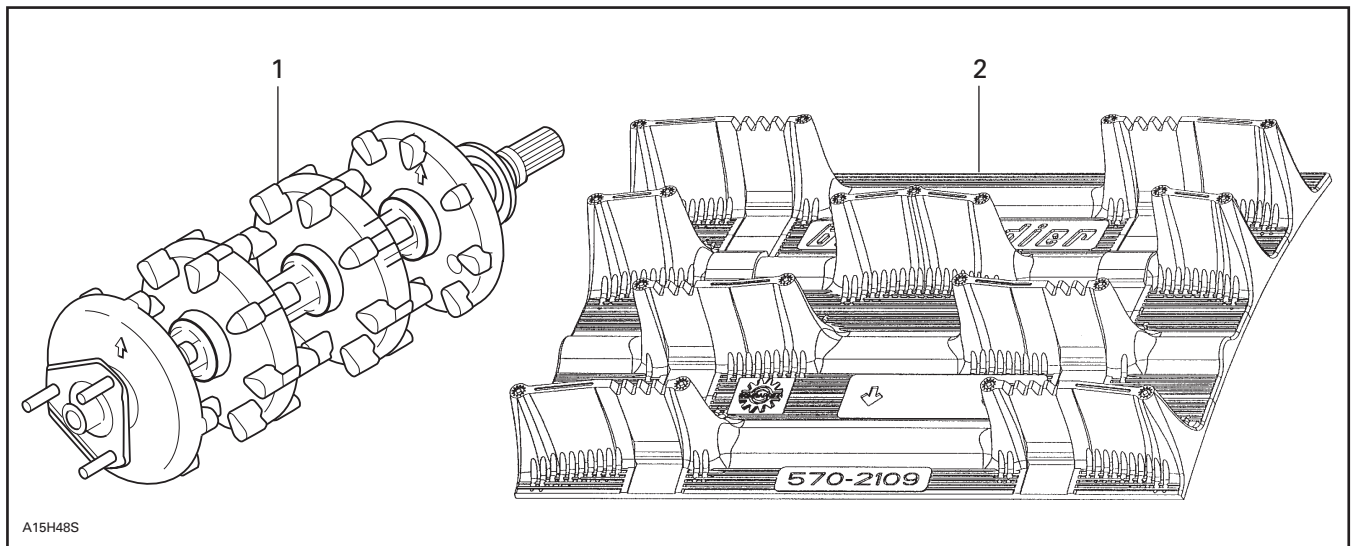

1. Drive Axle
2. Track

VEHICLE PREPARATION

NOTE: If additional information is required, refer to *Ski-Doo Shop Manual*, Section 07 for proper removal/installation procedure.

Raise rear of vehicle and block safely. Remove rear suspension and track.

Remove drive axle.

INSTALLATION PROCEDURE

Install new drive axle **no. 1**.

Install new track **no. 2**, paying close attention to the direction of rotation.

Reinstall rear suspension in tunnel.

Install front arm upper axle in existing holes.

Drill new hole to 8.4 mm (21/64 in) on center bracket.

Refer to illustration for proper location.

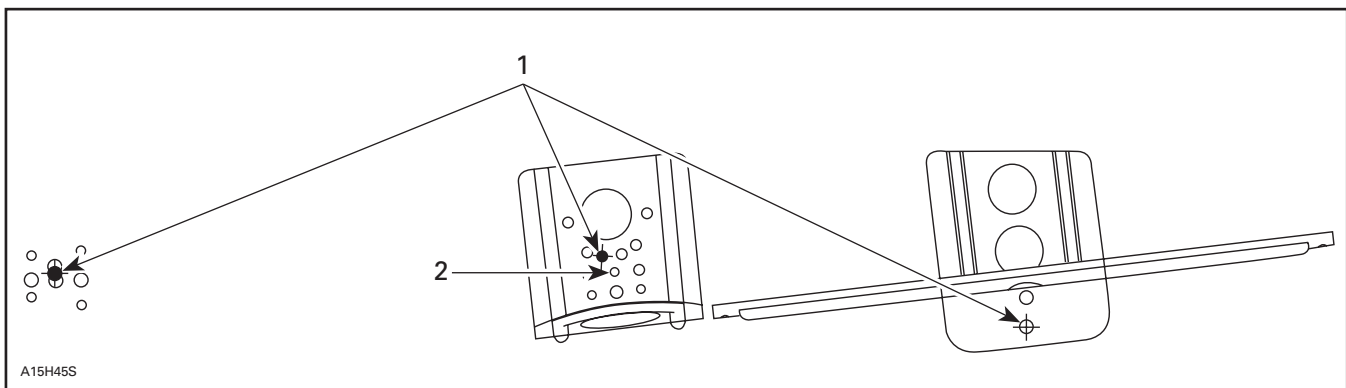

1. Existing holes

2. Drill new hole 8.4 mm (21/64 in)

Install wheel support axle using new holes in center bracket.

Secure rear suspension axle using lower holes on rear bracket.

Adjust drive chain tension and refill chaincase with Bombardier synthetic chaincase oil (P/N 413 8028 00).

Adjust track tension and alignment.

◆ WARNING

Before checking track tension and alignment, ensure that the track is free of all particles which could be thrown out while rotating. Keep hands, tools, feet and clothing clear of track. Ensure no one is standing in close proximity to the vehicle.

With rear of vehicle supported off the ground, start engine and allow the track to rotate **slowly**.

Check for proper operation of new track.



◆ **WARNING**

For safety reasons, this kit must be installed by an authorized Bombardier snowmobile dealer. Should removal of a locking device be required when undergoing disassembly/assembly, always replace with a new one. This instruction sheet should be given to the purchaser. This kit is designed for specific applicable models only. It is not recommended for vehicles other than those for which it was sold.

NOTE: Installation time is approximately 2.5 hours.

▼ **CAUTION**

Using this kit for application other than deep snow conditions will cause premature wear and possibly severe damage to the track.

PARTS TO BE INSTALLED

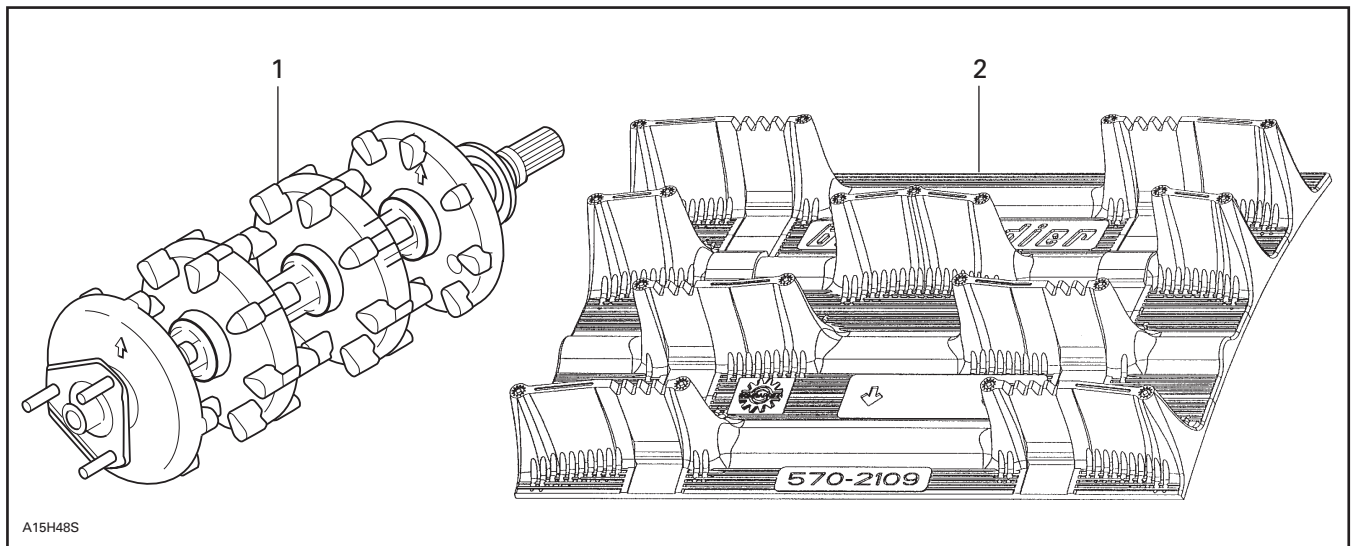

1. Drive Axle
2. Track

VEHICLE PREPARATION

NOTE: If additional information is required, refer to *Ski-Doo Shop Manual*, Section 07 for proper removal/installation procedure.

Raise rear of vehicle and block safely. Remove rear suspension and track.

Remove drive axle.

INSTALLATION PROCEDURE

Install new drive axle **no. 1**.

Install new track **no. 2**, paying close attention to the direction of rotation.

Reinstall rear suspension in tunnel.

Install front arm upper axle in existing holes.

Drill new hole to 8.4 mm (21/64 in) on center bracket.

Refer to illustration for proper location.

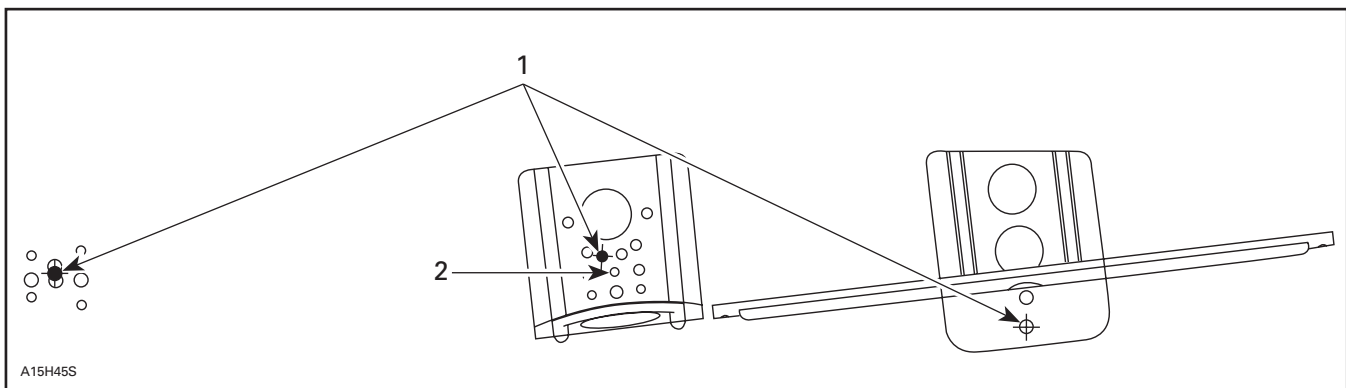

1. Existing holes

2. Drill new hole 8.4 mm (21/64 in)

Install wheel support axle using new holes in center bracket.

Secure rear suspension axle using lower holes on rear bracket.

Adjust drive chain tension and refill chaincase with Bombardier synthetic chaincase oil (P/N 413 8028 00).

Adjust track tension and alignment.

◆ WARNING

Before checking track tension and alignment, ensure that the track is free of all particles which could be thrown out while rotating. Keep hands, tools, feet and clothing clear of track. Ensure no one is standing in close proximity to the vehicle.

With rear of vehicle supported off the ground, start engine and allow the track to rotate **slowly**.

Check for proper operation of new track.

861 7651 00

| | | | |
|----|-------------|------------|---------------|
| 1. | 580 6563 00 | Drive Axle | Essieu moteur |
| 2. | 570 2109 00 | Track | Chenille |