



ski-doo[®]
Snowmobiles

**REVERSE TRANSMISSION KIT
(P/N 860 4235 00)**

◆ **WARNING**

For safety reasons, this kit must be installed by an authorized Bombardier snowmobile dealer. Should removal of a locking device be required when undergoing disassembly/assembly, always replace with a new one. This instruction sheet should be given to the purchaser. This kit is designed for specific applicable models only. It is not recommended for vehicles other than those for which it was sold

NOTE: Installation time is approximately 2.2 hours.

PARTS TO BE INSTALLED

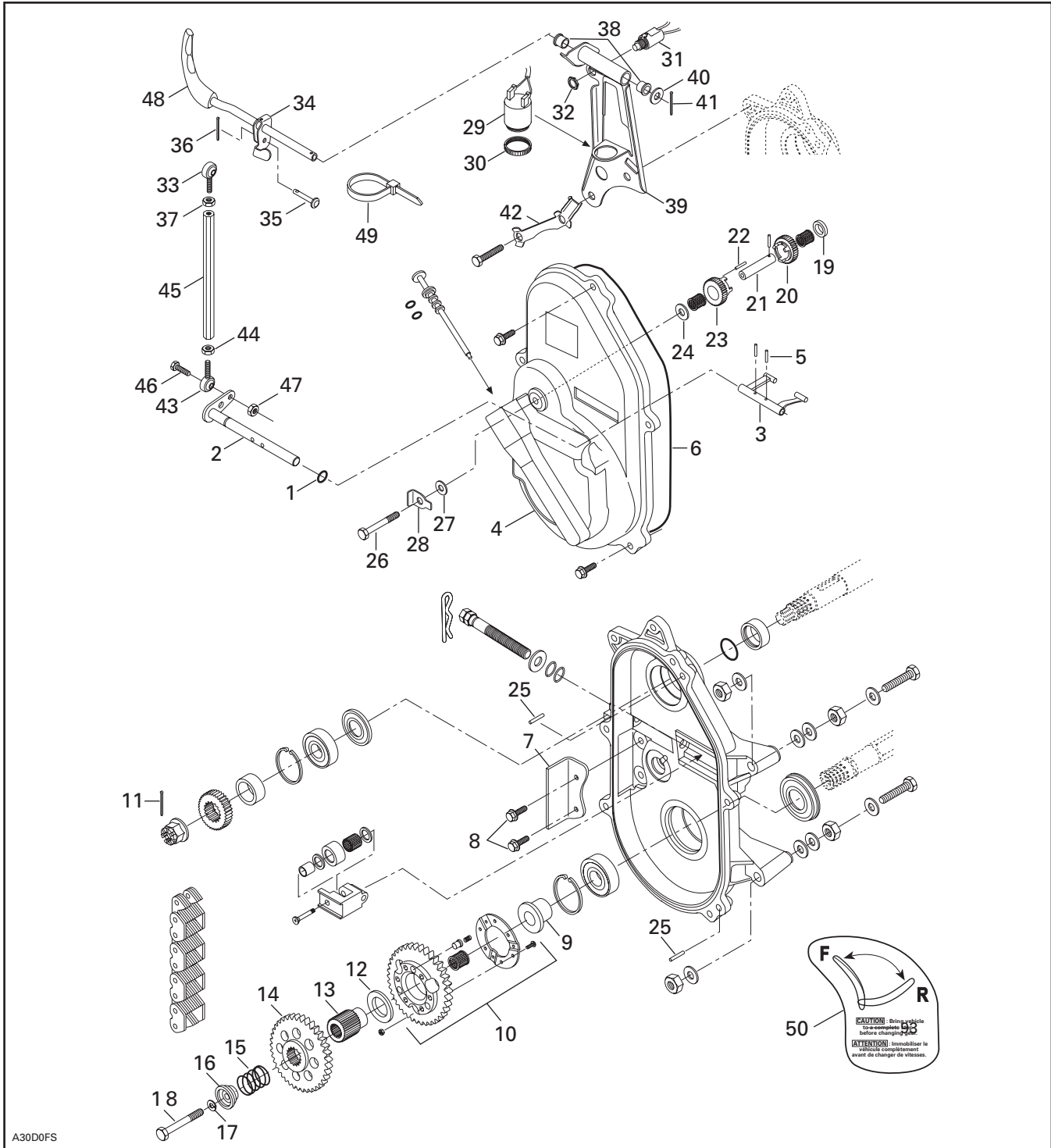

A30D0FS

1. O-ring
2. Fork Shaft
3. Fork
4. Chaincase Cover
5. Spring Pin (2)
6. O-ring
7. Chain Slider
8. Taptite Hex Bolt (2)
9. Retaining Ring
10. Lower Sprocket Assembly, 44 Tooth
11. Cotter Pin
12. Washer
13. Coupling Shaft
14. Sliding Sprocket, 56 Tooth
15. Release Spring
16. Cap
17. Lock Washer M10
18. Hex Bolt M10 x 50
19. Ring
20. Drive Sprocket, 19 Tooth
21. Reverse Shaft Assembly
22. Rubber Alignment Pin
23. Reverse Sprocket, 19 Tooth
24. Thrust Washer
25. Dowel Pin (2)
26. Hex Bolt M8-90
27. Copper Washer M8
28. Locking Tab
29. Backup Alarm
30. Plastic Nut
31. Switch Assembly
32. Nut
33. Ball Joint RH Side Thread
34. Welded Handle
35. Clevis Pin
36. Cotter Pin
37. Tie Rod Jam Nut M6
38. Flanged Bushing (2)
39. Handle Support
40. Washer
41. Cotter Pin
42. Locking Tab
43. Ball Joint LH Side Thread
44. Jam Nut LH Side Thread
45. Rod
46. Hex Bolt M6 x 20
47. Elastic Nut M6
48. Handle Grip
49. Locking Tie (2)
50. Decal
51. Chain

INSTRUCTIONS

CHAINCASE PREPARATION

1. Remove tuned pipes and muffler.
2. Remove chain tension.

Chaincase Cover

1. Install O-ring **no. 1** on fork shaft **no. 2** and spread grease on it.
2. Install fork **no. 3** and shaft in new chaincase cover **no. 4**.
3. Secure with spring pins **no. 5**.
4. Install O-ring **no. 6** in cover.

Finalizing Chaincase Assembly

1. Install chain slider **no. 7** and secure with bolts **no. 8**.
2. Install retaining ring **no. 9** and lower sprocket ass'y **no.10** over drive axle and properly mesh with chain. Change chain **no. 51** if required.

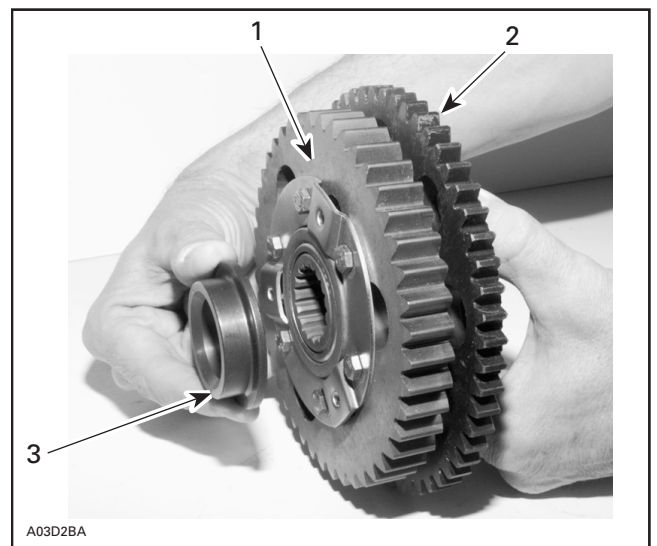

1. 44 tooth gear
2. 56 tooth gear
3. Retaining ring

3. Reinstall spacer and upper sprocket, then torque castellated nut to 75 N•m (55 lbf•ft). Secure nut with a new cotter pin **no. 11**.

4. Install washer **no. 12** onto coupling shaft **no. 13** then insert between sliding sprocket and lower sprocket ass'y.
5. Install sliding sprocket **no. 14**, release spring **no. 15**, cap **no. 16**, lock washer **no. 17** and bolt **no. 18**.
6. Apply Loctite 271 (red) on bolt threads, use sparingly. Torque bolt 42 to 45 N•m (31 to 33 lbf•ft).
7. On reverse shaft **no. 21**, install ring **no. 19** with drive sprocket **no. 20**, making sure to properly position spring pin in housing slot.
8. Install rubber alignment pin **no. 22** and reverse sprocket **no. 23**. Drive sprocket hole and reverse gear hole must be aligned to insert rubber alignment pin.
9. Install thrust washer **no. 24**.

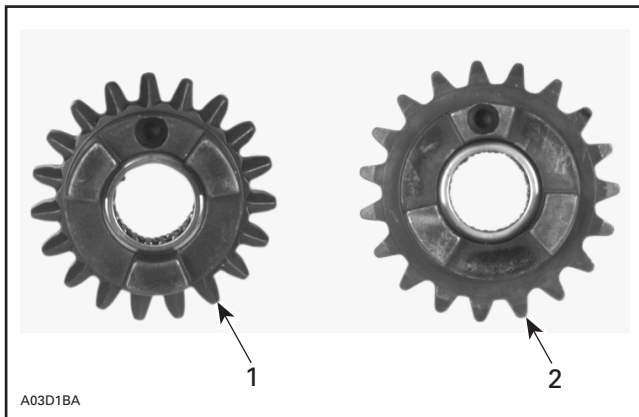

1. Reverse sprocket (hole between dogs)
2. Drive sprocket (hole on dog)

10. Insert dowel pins **no. 25** into chaincase.
11. Fully tighten chain adjusting screw by hand, then back off only far enough for hair pin to engage in locking hole.
12. Join chaincase cover to chaincase by passing fork tabs behind sliding sprocket lip.

▼ CAUTION

Chaincase cover must completely lay against chaincase.

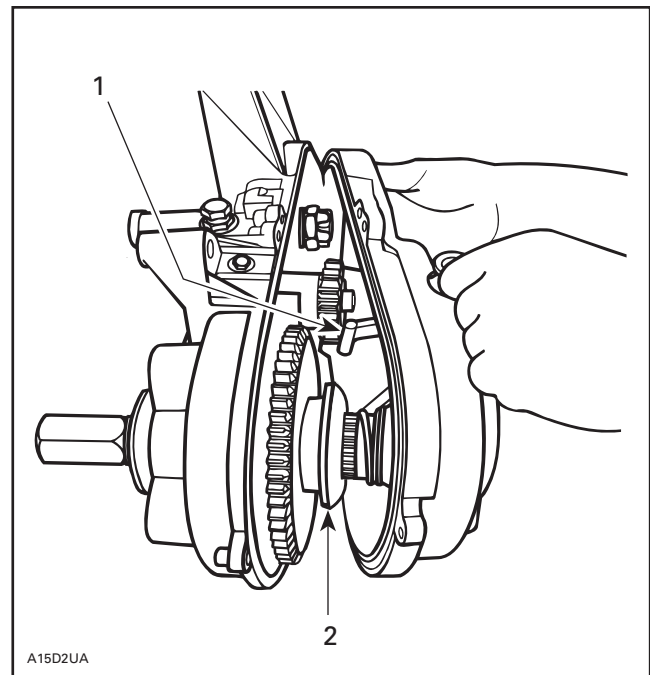

1. Fork tabs
2. Sliding sprocket lip

13. Tighten chaincase bolts in a criss-cross sequence beginning with top center.
14. Install reverse shaft bolt **no. 26** with copper washer **no. 27** against chaincase cover and locking tab **no. 28** against bolt head. Position angle end of tab to rear then torque bolt 13.5 to 17 N•m (123 to 155 lbf•in). Bend locking tab against bolt head.

SHIFTING LINKAGE ASSEMBLY

1. Screw jam nut **no. 37** to ball joint **no. 33** then ball joint to bar **no. 45** upper end.
2. Screw jam nut **no. 44** to ball joint **no. 43** then ball joint to bar lower end.
3. Secure lower ball joint to fork shaft using bolt **no. 46** and nut **no. 47**. Both jam nuts **no. 37** and **no. 44** will serve as shifter rod (bar) adjusters.
4. Install 2 flanged bushings **no. 38** into handle support **no. 39** and insert welded handle **no. 34**. Install washer **no. 40** and secure with cotter pin **no. 41**.

Backup Alarm Installation

1. Install backup alarm **no. 29** into hole provided in handle support, secure using plastic nut **no. 30**.
2. Install switch assembly **no. 31** into hole provided in handle support and secure using nut **no. 32**.

SHIFTING LINKAGE ASSEMBLY INSTALLATION

1. Drill 12.5 mm (1/2 in) hole in console. Refer to alignment embossement behind console for positioning.
2. Release locking tabs then remove bolts that are retaining brake caliper to chaincase.
3. Slide handle portion of shifting linkage ass'y through hole in console. Position handle support so as the 2 lower holes align with existing holes for brake caliper.
4. Install locking tab **no. 42** and secure using existing bolts. Bend locking tabs into place.
5. Insert ball joint **no. 33** in welded handle, secure with clevis pin **no. 35** and Cotter pin **no. 36**.
6. Connect terminals to the alarm, make sure that RED/BLUE wire is connected to alarm negative post. Connect tab connector housing to vehicle harness. Secure wiring harness with locking tie **no. 49**.
7. Install grip **no. 48**.

ADJUSTMENTS

1. Shift into reverse gear.

NOTE: If it is impossible to shift into reverse gear, shorten tie-rod and try again. Turn the brake disk to free the gears. If it is still impossible, check if the fork engages in the sliding gear or disassemble the cover to inspect components.

2. Completely loosen tie rod jam nut **no. 37** on the gear shift linkage.
3. Turn shifter handle in reverse position making sure all play is removed.

NOTE: It is normal to feel a slight friction when shifting into gear.

4. Statically test transmission operation in forward and reverse positions.
5. Hold linkage and tighten tie rod jam nut **no. 37**.

6. Adjust backup alarm so that it sounds when transmission is in reverse gear while engine is running.
7. Install decal **no. 50** on console above handle.

FILLING WITH OIL

1. Fill chaincase with chaincase oil (P/N 413 8019 00). Oil capacity is approximately 250 mL (8 oz).
2. Check oil level with dipstick, oil level must be between the marks.



1. Oil level marks

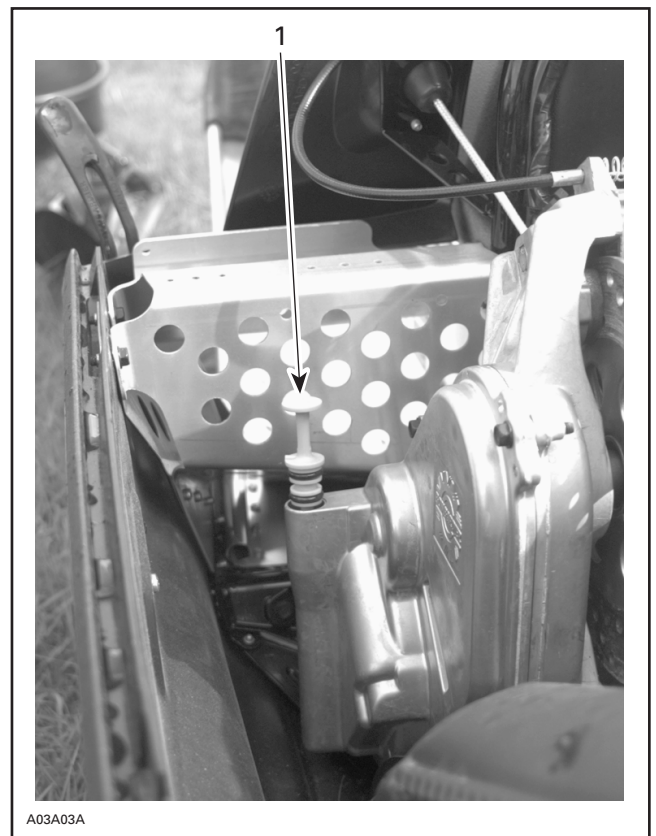

1. Dipstick

3. Reinstall tuned pipes and muffler.
4. Test drive to ensure proper operation of transmission.

860 4235 00

1.	414 7732 00	O-ring	Joint torique
2.	504 1475 00	Fork Shaft	Arbre de fourchette
3.	504 0758 00	Fork	Fourchette
4.	504 1468 00	Chaincase Cover	Couvercle du carter de chaîne
5.	414 7725 00	Spring Pin (2)	Goupille-ressort (2)
6.	414 3623 00	O-ring	Joint torique
7.	504 1469 00	Chain Slider	Coulisseau de chaîne
8.	732 6010 67	Taptite Hex Bolt (2)	Boulon hexagonal autotaraudeur (2)
9.	504 0763 00	Retaining Ring	Bague de retenue
10.	581 0968 00	Lower Sprocket Assembly, 44 Tooth	Pignon inférieur complet, 44 dents
11.	371 0063 00	Cotter Pin	Goupille fendue
12.	504 0943 00	Washer	Rondelle
13.	504 0977 00	Coupling Shaft	Arbre d'accouplement
14.	504 0968 00	Sliding Sprocket, 56 Tooth	Pignon coulissant, 56 dents
15.	504 0966 00	Release Spring	Ressort de rappel
16.	504 0991 00	Cap	Capuchon
17.	224 7011 88	Lock Washer M10	Rondelle-frein M10
18.	222 0050 65	Hex Bolt M10 x 50	Boulon hexagonal M10 x 50
19.	504 0787 00	Ring	Bague
20.	581 0969 00	Drive Sprocket, 19 Tooth	Pignon d'entraînement, 19 dents
21.	580 5906 00	Reverse Shaft Assembly	Arbre de marche arrière (complet)
22.	570 0486 00	Rubber Alignment Pin	Tige d'alignement de caoutchouc
23.	581 1222 00	Reverse Sprocket, 19 Tooth	Pignon de marche arrière, 19 dents
24.	504 0773 00	Thrust Washer	Rondelle de butée
25.	732 6200 01	Dowel Pin (2)	Goupille d'assemblage (2)
26.	222 0890 65	Hex Bolt M8-90	Boulon hexagonal M8-90
27.	504 0829 00	Copper Washer M8	Rondelle de cuivre M8
28.	504 1500 00	Locking Tab	Patte de verrouillage
29.	414 7921 02	Backup Alarm	Avertisseur de marche arrière
30.	414 8051 01	Plastic Nut	Écrou de plastique
31.	515 1751 00	Switch Assembly	Interrupteur (complet)
32.	732 6100 75	Nut	Écrou
33.	414 7734 00	Ball Joint RH Side Thread	Joint à rotule à filetage à DROITE
34.	504 1477 00	Welded Handle	Poignée soudée
35.	415 1038 00	Clevis Pin	Axe de chape
36.	371 8012 00	Cotter Pin	Goupille fendue

860 4235 00

37.	228 0610 45	Tie Rod Jam Nut M6	Contre-écrou de la barre d'accouplement M6
38.	572 1060 00	Flanged Bushing (2)	Douille à épaulement (2)
39.	504 1476 00	Handle Support	Support de poignée
40.	503 0951 00	Washer	Rondelle
41.	371 8008 00	Cotter Pin	Goupille fendue
42.	507 0319 00	Locking Tab	Patte de verrouillage
43.	414 7735 00	Ball Joint LH Side Thread	Joint à rotule à filetage à GAUCHE
44.	732 6100 46	Jam Nut LH Side Thread	Contre-écrou à filetage à GAUCHE
45.	504 1474 00	Rod	Barre d'accouplement
46.	222 0620 65	Hex Bolt M6 x 20	Boulon hexagonal M6 x 20
47.	228 5610 45	Elastic Nut M6	Écrou d'arrêt élastique M6
48.	570 0646 00	Handle Grip	Poignée
49.	414 1152 00	Locking Tie (2)	Attache (2)
50.	418 0016 03	Decal	Autocollant
51.	412 1069 00	Chain	Chaîne