



**◆ WARNING**

For safety reasons, this kit must be installed by an authorized Bombardier snowmobile dealer. Should removal of a locking device be required when undergoing disassembly/assembly, always replace with a new one. This instruction sheet should be given to the purchaser. This kit is designed for specific applicable models only. It is not recommended for vehicles other than those for which it was sold.

NOTE: Installation time is approximately 1.0 hour.

**PARTS TO BE INSTALLED**

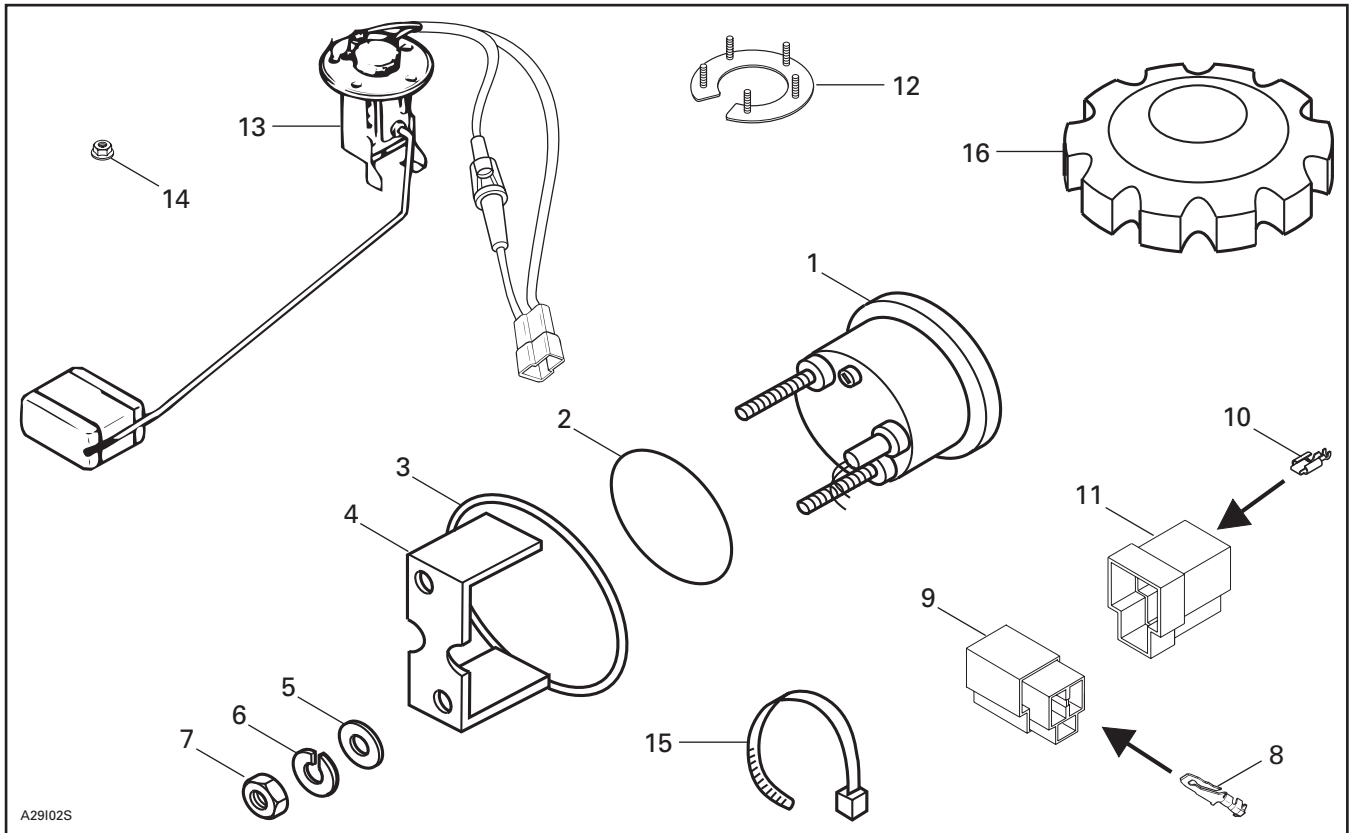

A29102S

- |                         |                                |
|-------------------------|--------------------------------|
| 1. Fuel Gauge           | 9. 3-connector Housing         |
| 2. Gauge O-ring         | 10. Female Connector (3)       |
| 3. Formed Washer        | 11. 3-connector Housing        |
| 4. Gauge Holder         | 12. Float Support              |
| 5. Flat Washer 7/32 (2) | 13. Fuel Sensor                |
| 6. Lock Washer (2)      | 14. Elastic Flanged Nut M4 (5) |
| 7. Nut (2)              | 15. Locking Tie                |
| 8. Male Connector (3)   | 16. Fuel Tank Cap              |

# INSTRUCTIONS

## Fuel Sensor Installation

Disconnect battery (if equipped).

### ◆ WARNING

Always disconnect battery cables exactly in the specified order, **BLACK** negative cable first. Electrolyte or fuel vapors can be present.

Open seat.

Close fuel shut-off valve (if so equipped).

Drain fuel tank completely.

Position tank template (found on the last pages of this document) onto tank recess. Mark all hole centers.

Using a 42 mm (1-21/32 in) hole saw cut tank fuel sensor hole.

**NOTE:** Put a small dab of grease on drill bit to minimize the quantity of particles from falling into fuel tank.

Using a 4.2 mm (11/64 in) drill bit, drill the 5 fuel sensor retaining screw holes using marks as a center guide.

Thoroughly clean fuel tank.

Install float support **no. 12** (gasket included with fuel sensor) and fuel sensor **no. 13**.

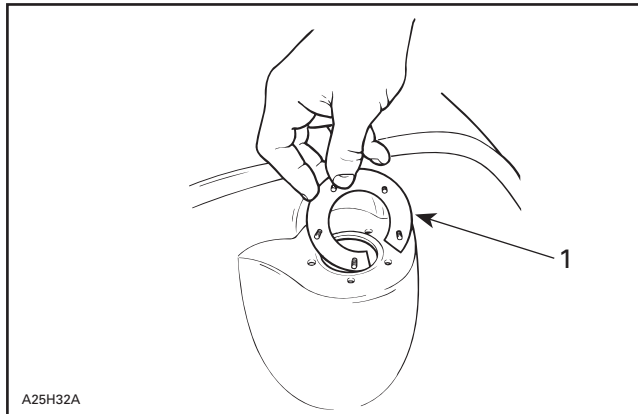

1. Float support

**NOTE:** Fuel sensor and gasket must be installed outside tank; float support inside tank.

Secure with elastic flanged nuts **no. 14** (M4), initially torque to 1 N•m (8 lbf•in) then finalize torque in criss-cross sequence to 2.5 N•m (22 lbf•in).

Replace fuel tank cap with the one supplied **no. 16**.

Connect fuel sensor harness to vehicle harness. Do not close seat yet.

### ◆ WARNING

Verify the fuel system, if any leak is found, do not start the engine and wipe off any fuel leakage. Failure to correct a leak could lead to an explosion.

## Electric Fuel Gauge Installation

Position dashboard template (found on the last pages of this document) on the center of the right side of dashboard, cut a 63.5 mm (2.5 in) hole.

### ▼ CAUTION

Make sure not to damage oil tank cap. Be sure there are no wires behind dashboard that might be damaged.

Install male connectors **no. 8** on gauge wires and position in 3-connector housing **no. 9** as per following illustration.

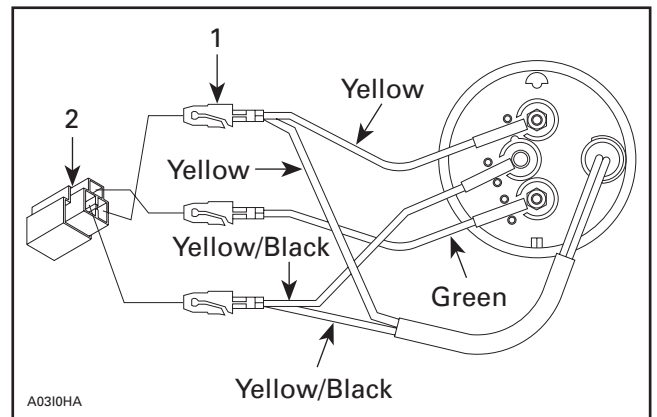

1. Male connector  
2. 3-connector housing

Remove existing vehicle 4-connector housing and connectors.

Replace with 3-connector housing **no. 11** and female connectors **no. 10**.

Install electric fuel gauge **no. 1** with gauge O-ring **no. 2**, formed washer **no. 3** and gauge holder **no. 4** with washers **no. 5**, lock washers **no. 6** and nuts **no. 7**.

Connect housings.

Secure wire harness with a tie rap **no. 15**.

Test gauge operation with fuel tank empty and full. Ensure there is no fuel leak at fuel sensor.

Close seat.

# DASHBOARD TEMPLATE

Use this template to position drill hole for gauge in dashboard.

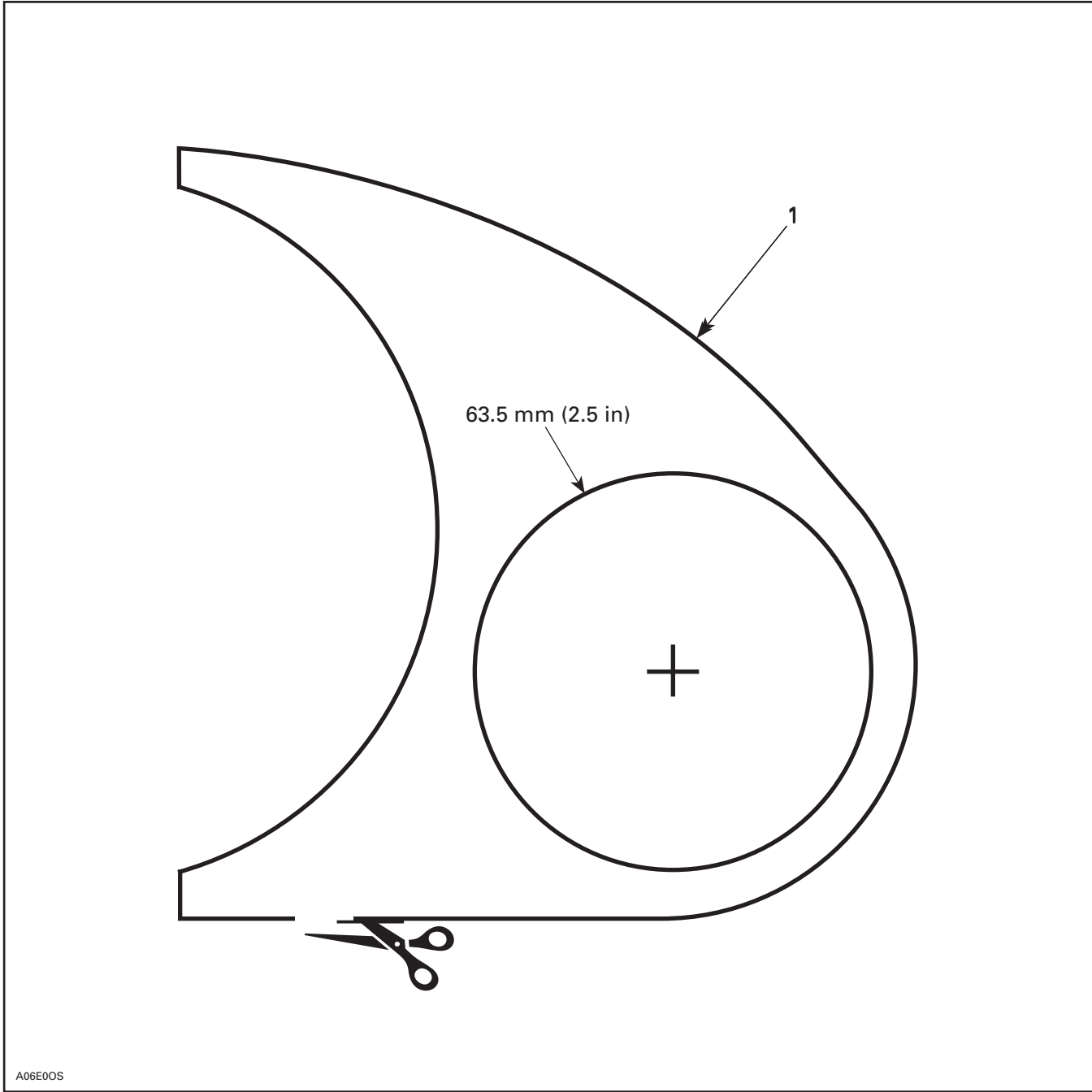

1. Position over dashboard decal

THIS PAGE IS PURPOSELY BLANK

# TANK TEMPLATE

Use this template to position drill hole for fuel sensor on tank.

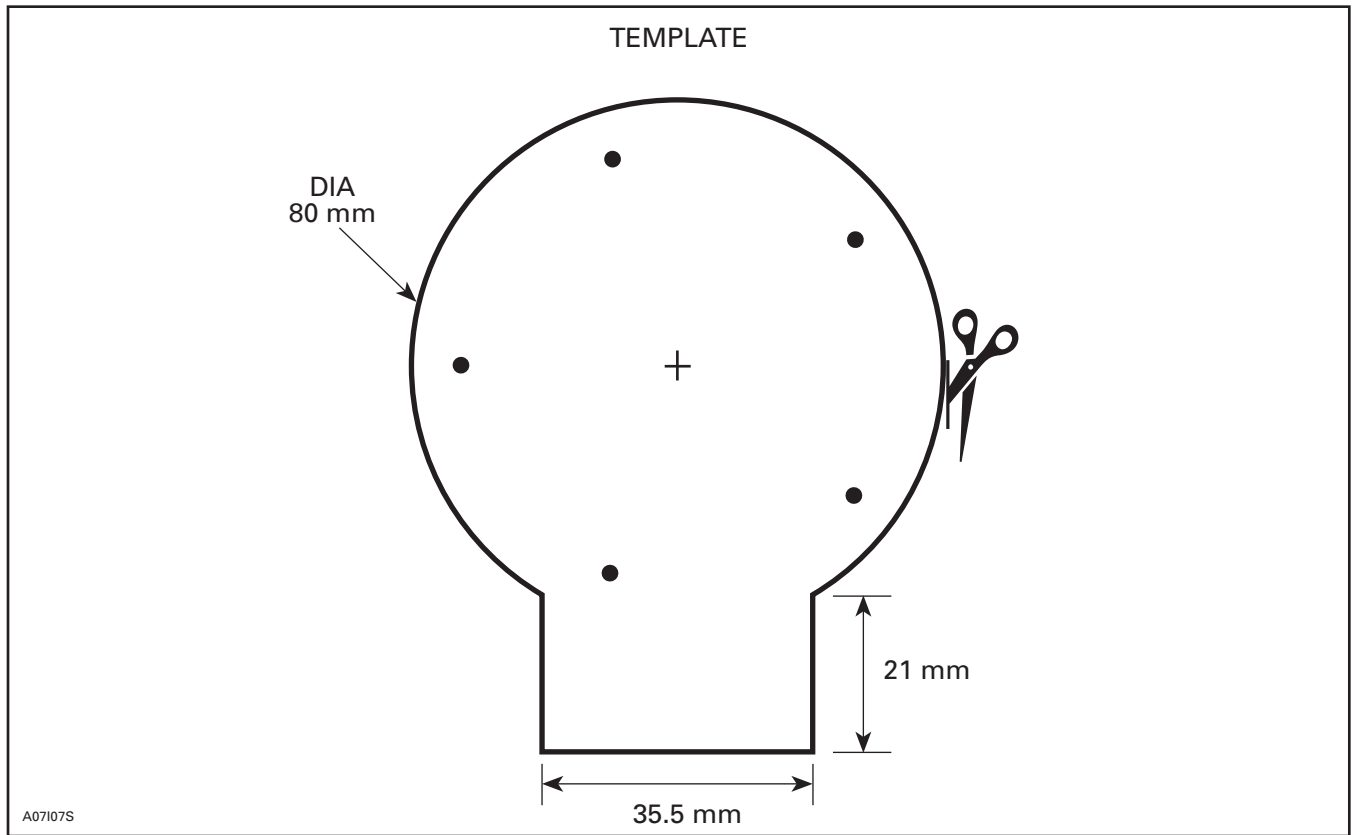

1. Position over tank

## 861 5039 00

1.	415 0981 00	Fuel Gauge	Indicateur de niveau de carburant
2.	414 8072 00	Gauge O-ring	Joint torique de l'indicateur
3.	517 2586 00	Formed Washer	Rondelle formée
4.	414 8066 00	Gauge Holder	Support de l'indicateur
5.	391 3017 00	Flat Washer 7/32 (2)	Rondelle plate 7/32 (2)
6.	414 8337 00	Lock Washer (2)	Rondelle-frein (2)
7.	414 8336 00	Nut (2)	Écrou (2)
8.	561 5034 00	Male Connector (3)	Raccord mâle (3)
9.	409 2042 00	3-connector Housing	Logement de raccords à 3 circuits
10.	561 5032 00	Female Connector (3)	Raccord femelle (3)
11.	409 2043 00	3-connector Housing	Logement de raccords à 3 circuits
12.	513 0325 00	Float Support	Support de flotteur
13.	<u>410 1123 00</u>	Fuel Sensor	Sonde de niveau de carburant
14.	228 7410 45	Elastic Flanged Nut M4 (5)	Écrou à épaulement élastique M4 (5)
15.	414 1152 00	Locking Tie	Attache
16.	572 0396 00	Fuel Tank Cap	Bouchon du réservoir de carburant

