



◆ WARNING

For safety reasons, this kit must be installed by an authorized Bombardier snowmobile dealer. Should removal of a locking device be required when undergoing disassembly/assembly, always replace with a new one. This instruction sheet should be given to the purchaser. This kit is designed for specific applicable models only. It is not recommended for vehicles other than those for which it was sold.

NOTE: Installation time is approximately 0.5 hour.

PARTS TO BE INSTALLED

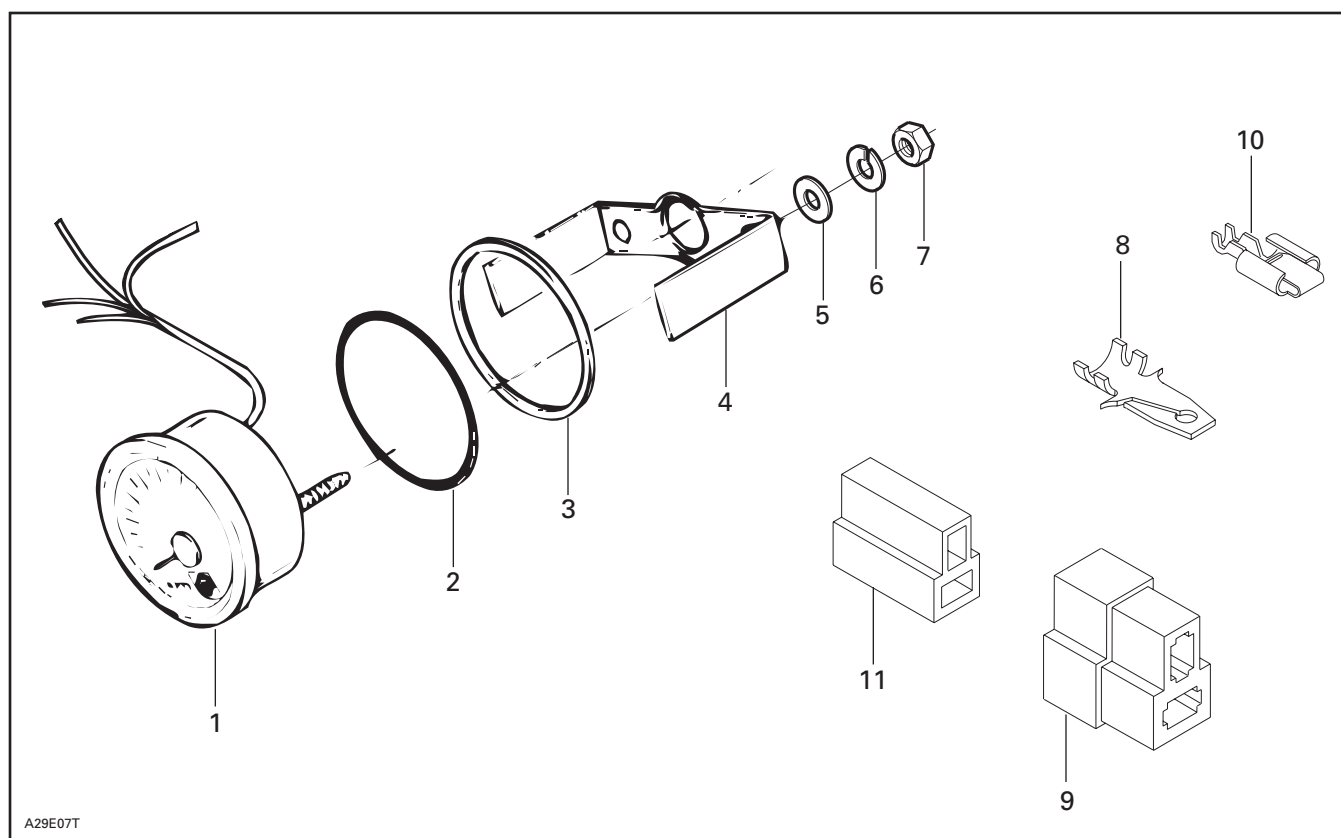

- | | |
|-----------------------|------------------------------------|
| 1. Tachometer | 7. Nut (2) |
| 2. Gauge Packing Ring | 8. Male Terminal (4) |
| 3. Ring | 9. Male 2-connector Housing (2) |
| 4. Housing Support | 10. Female Terminal (4) |
| 5. Flat Washer (2) | 11. Female 2-connector Housing (2) |
| 6. Lock Washer (2) | |

INSTRUCTION

All Models

Disconnect battery (if equipped).

◆ WARNING

Always disconnect battery cables exactly in the specified order. Disconnect BLACK negative ground cable **first**, then RED positive cable.

S Series Models prior to 1998

Remove female 4-connector housing from vehicle wiring harness and remove female terminals.

Join both YELLOW/BLACK wires together and install one female terminal **no. 10**. Repeat with both YELLOW wires, then insert both female terminals into female 2-connector housing **no. 11**.

Install **no. 8** male terminals on tachometer wires and insert into male 2-connector housing **no. 9** as per following illustration.

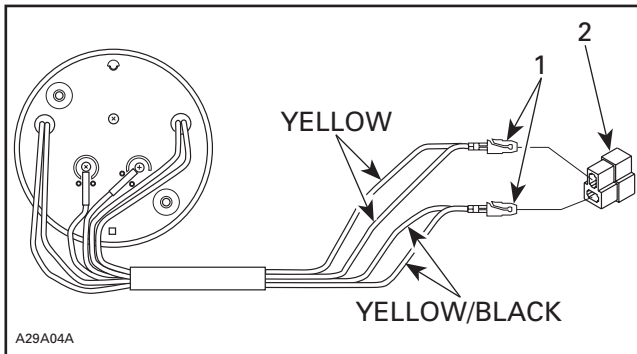

1. Male terminal
2. Male 2-connector housing

Using supplied template, drill a 80 mm (3-1/8 in) hole in the instrument panel.

▼ CAUTION

Ensure there are no wires behind dashboard that might be damaged.

Install gauge packing ring **no. 2** around tachometer **no. 1** then insert it in its hole.

Secure with ring **no. 3**, housing support **no. 4**, flat washers **no. 5**, lock washers **no. 6** and nuts **no. 7**. Tighten firmly.

INSTALLATION

Connect housings.

Reconnect battery (if equipped).

◆ WARNING

Always connect battery cables exactly in the specified order. Connect RED positive cable **first** then BLACK negative ground cable.

Make sure tachometer operates properly.

Skandic SWT/WT/WT LC

Cut one piece of 18 gauge YELLOW/BLACK wire and one piece of 18 gauge YELLOW wire to 660 mm (26 in) long. (*Wires are not supplied with the kit*).

Cut wires to 330 mm (13 in) to have 2 YELLOW/BLACK wires and 2 YELLOW wires.

Install female terminal **no. 10** to one end of each wire.

Insert 2 female terminals **no. 10**, (1 YELLOW/BLACK wire and 1 YELLOW wire) into one female 2-connector housing **no. 11**. Repeat same procedure using other female 2-connector housing **no. 11**.

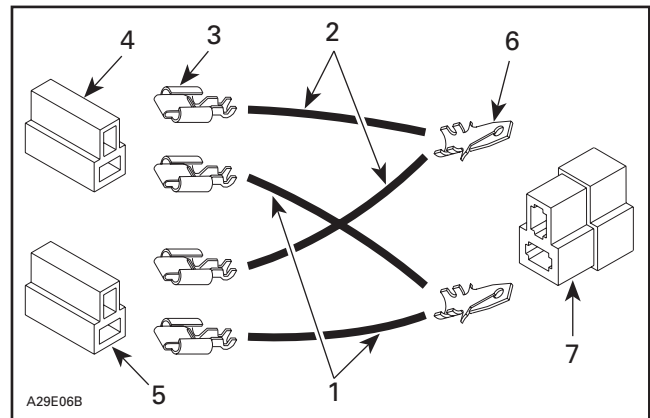

1. YELLOW/BLACK wires
2. YELLOW wires
3. Female terminals
4. Housing A
5. Housing B
6. Male terminals
7. Housing C

Join other ends of YELLOW/BLACK wires together then install male terminal **no. 8**. Repeat same procedure with YELLOW wires.

Insert 2 male terminals **no. 8** into male 2-connector housing **no. 9**.

Install **no. 8** male terminals on tachometer wires and insert into male 2-connector housing **no. 9** as per following illustration.

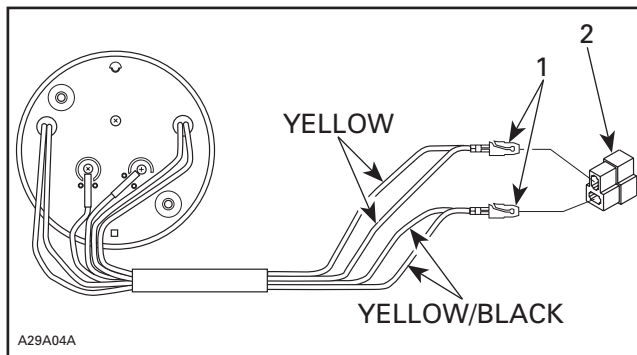

1. Male terminal
2. Male 2-connector housing

Using supplied template, drill a 80 mm (3-1/8 in) hole in the instrument panel.

▼ CAUTION

Ensure there are no wires behind dashboard that might be damaged.

Install gauge packing ring **no. 2** around tachometer **no. 1** then insert it in its hole.

Secure with ring **no. 3**, housing support **no. 4**, flat washers **no. 5**, lock washers **no. 6** and nuts **no. 7**. Tighten firmly.

INSTALLATION

Unplug connector housing from speedometer.

Connect housing A to speedometer.

Connect housing B to tachometer.

Connect housing C to vehicle wiring harness.

Reconnect battery (if equipped).

◆ WARNING

Always connect battery cables exactly in the specified order. Connect RED positive cable **first** then BLACK negative ground cable.

Verify that both speedometer and tachometer operate properly.

THIS PAGE IS PURPOSELY BLANK

DRILLING TEMPLATE

Use this template to properly drill the hole in the dashboard.

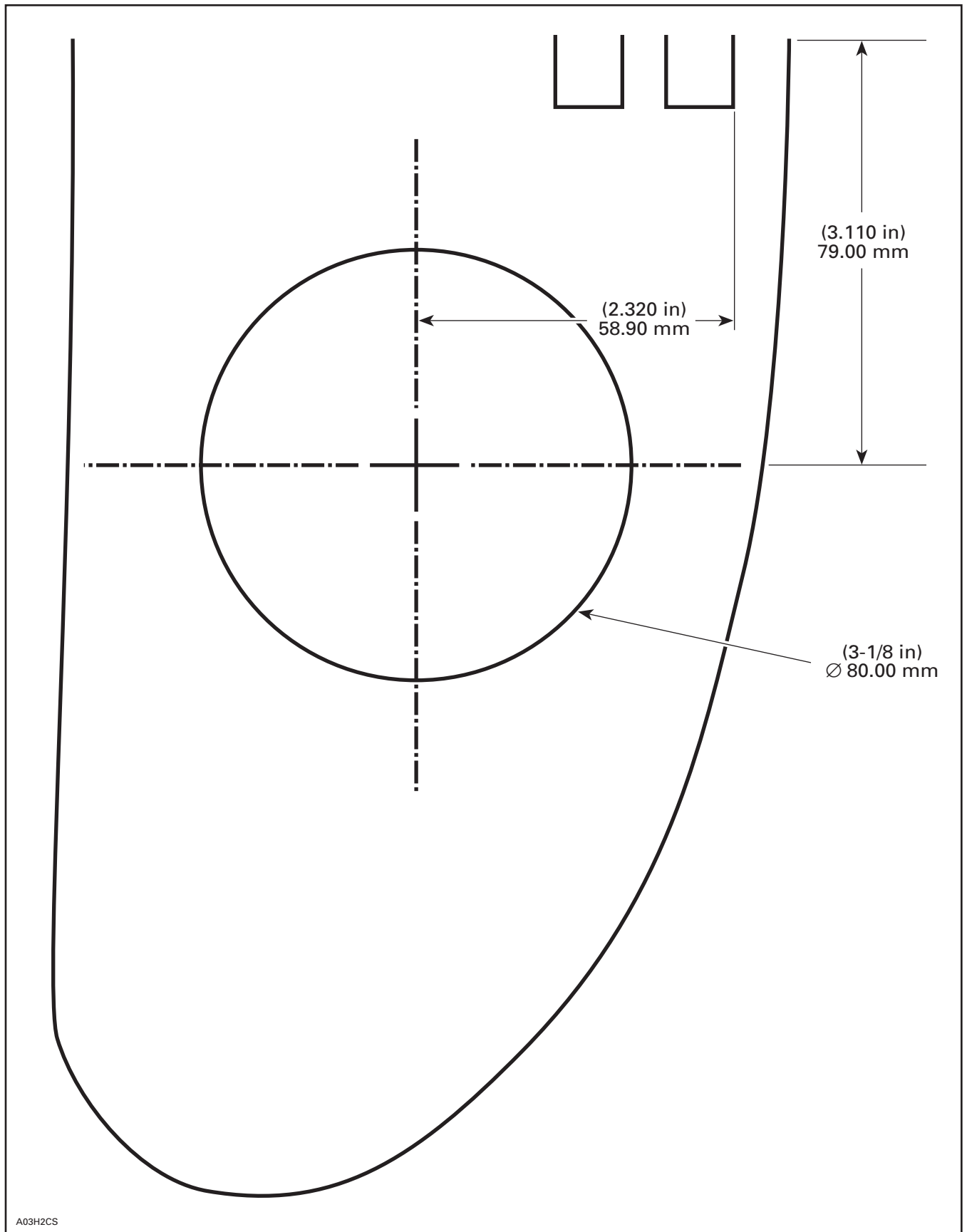

861 7606 00

| | | | |
|-----|-------------|--------------------------------|--|
| 1. | 415 0980 00 | Tachometer | Tachymètre |
| 2. | 414 8071 00 | Gauge Packing Ring | Joint torique |
| 3. | 517 2585 00 | Ring | Anneau |
| 4. | 414 8065 00 | Housing Support | Support d'indicateur |
| 5. | 414 8068 00 | Flat Washer (2) | Rondelle plate (2) |
| 6. | 414 8067 00 | Lock Washer (2) | Rondelle-frein (2) |
| 7. | 414 8069 00 | Nut (2) | Écrou (2) |
| 8. | 561 5034 00 | Male Terminal (4) | Raccord mâle (4) |
| 9. | 409 2045 00 | Male 2-connector Housing (2) | Logement de raccord mâle à 2 circuits (2) |
| 10. | 561 5031 00 | Female Terminal (4) | Raccord femelle (4) |
| 11. | 409 2046 00 | Female 2-connector Housing (2) | Logement de raccord femelle à 2 circuits (2) |