



◆ WARNING

For safety reasons, this kit must be installed by an authorized Bombardier snowmobile dealer. Should removal of a locking device be required when undergoing disassembly/assembly, always replace with a new one. This instruction sheet should be given to the purchaser. This kit is designed for specific applicable models only. It is not recommended for vehicles other than those for which it was sold.

NOTE: Installation time is approximately 2.5 hours.

PARTS TO BE INSTALLED

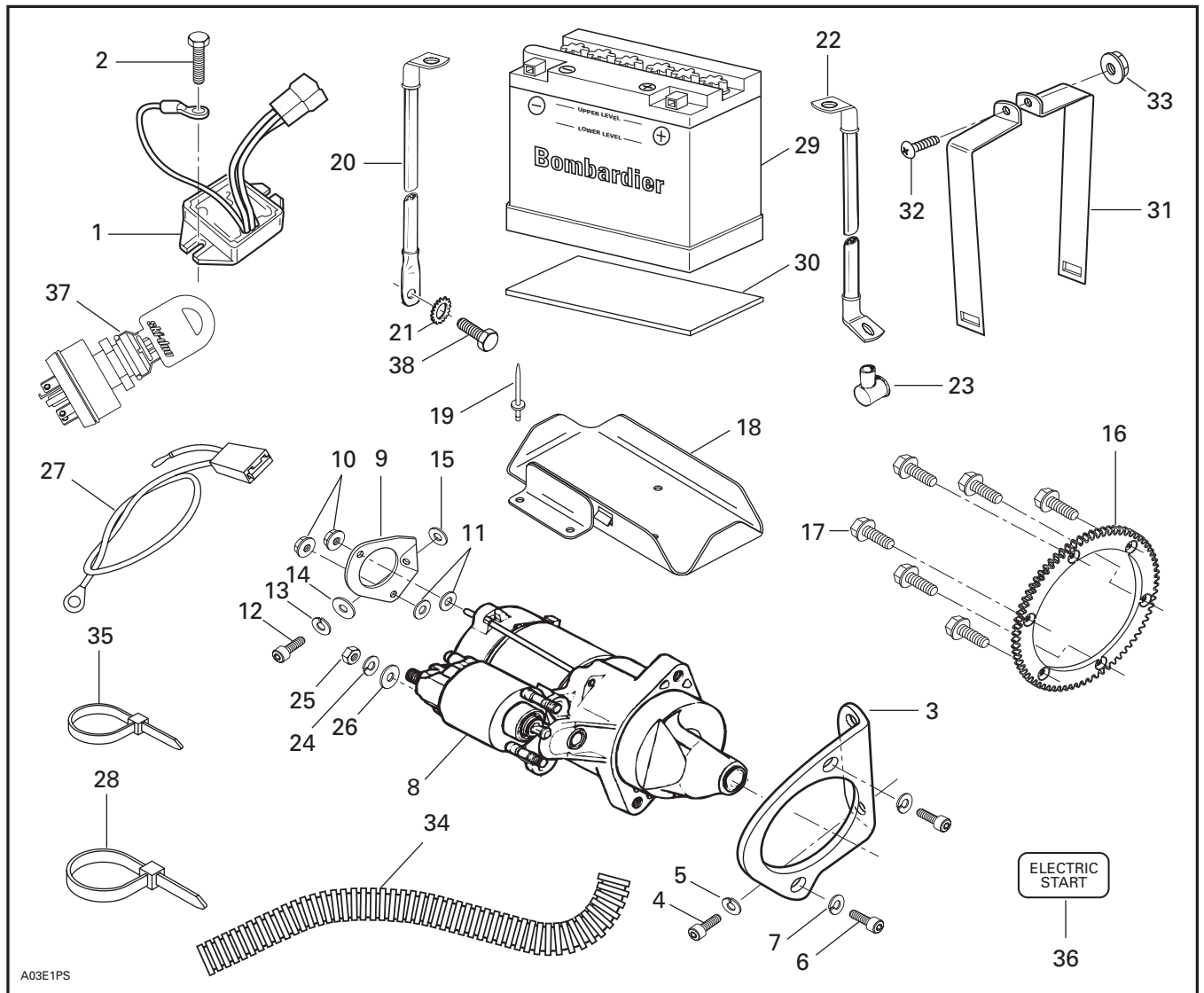

1. Regulator/Rectifier
2. Self-tapping Screw M6 x 16 (2)
3. Starter Support PTO
4. Socket Screw M8 x 20 (2)
5. Lock Washer M8 (2)
6. Socket Screw M8 x 25 (2)
7. Lock Washer M8 (2)
8. Starter
9. Starter Support MAG
10. Flanged Elastic Nut M5 (2)
11. Flat Washer (2)
12. Socket screw M8 x 20
13. Lock Washer M8
14. Flat Washer M8
15. Hardened Washer (2)
16. Ring Gear
17. Self-tapping Screw M8 x 16 (6)
18. Battery Seat
19. Rivet (5)
20. Battery Ground Cable (BLACK)
21. Star Washer
22. Battery Positive Cable (RED)
23. Protector Cap (2)
24. Lock Washer M8
25. Hex. Nut M8
26. Flat Washer M8
27. Fuse Holder
28. Locking Tie (8)
29. Battery
30. Rubber Insulator
31. Steel Strip (2)
32. Hex. Screw M5 x 16
33. Hex. Flanged Nut M5
34. Protector
35. Locking Tie
36. Decal
37. Ignition Switch
38. Self-tapping Screw
39. Elbow Fitting (Not Illustrated)

VEHICLE PREPARATION

Battery

NOTE: Refer to the *Ski-Doo Shop Manual* for proper battery removal/installation procedure.

◆ WARNING

Never charge or boost battery while connected or installed in vehicle.

Vehicle

Remove exhaust system, belt guard and drive belt.

Unfasten spark plug cables from fan housing. Unplug spark plug caps.

Unplug electronic box harness underneath carburetors by inserting a screwdriver in the connector tab and pull tab as illustrated.

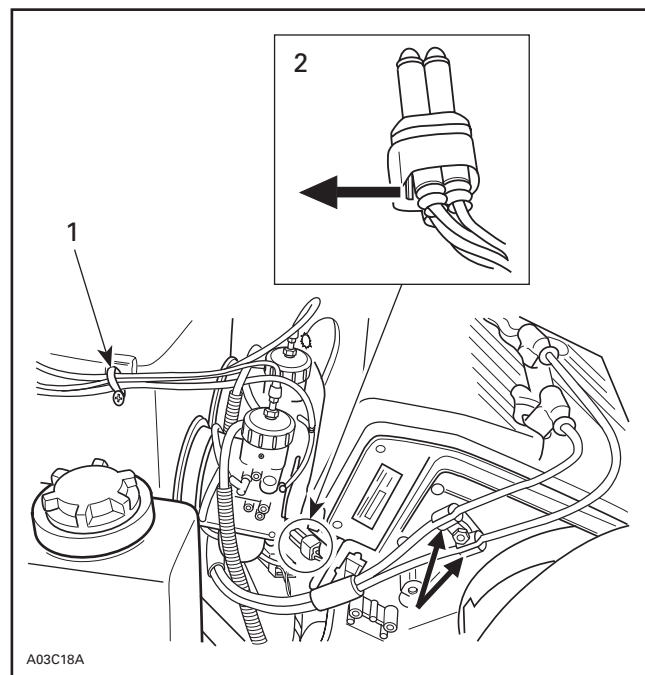

1. Plastic clip
2. CDI box harness connector

Open the plastic clip that is positioned on the air intake silencer. Insert a flat tip screw driver and turn as illustrated.

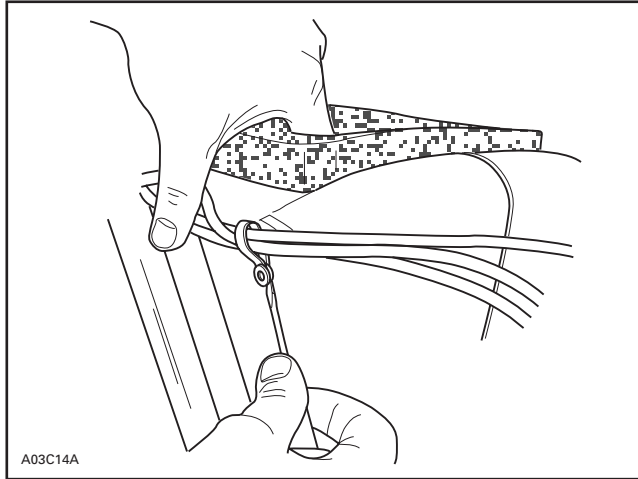

Remove the air intake silencer.

Empty fuel tank, change hose fitting with an elbow type fitting **no. 39** and outlet toward exterior, to clear battery corner.

INSTALLATION

Regulator/Rectifier

1. Remove original regulator/rectifier, located along RH side member of frame. Secure new regulator/rectifier **no. 1** using self tapping screws **no. 2**. Use 1 screw to connect the ground wire from regulator/rectifier as shown.

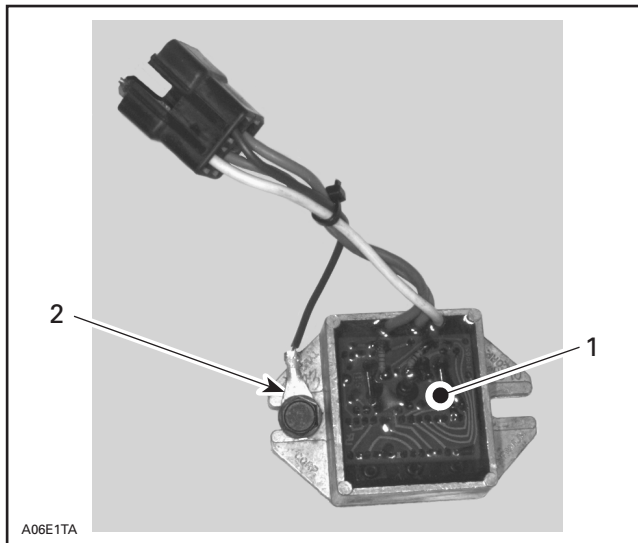

1. Regulator/rectifier
2. Connect ground wire here

2. Apply silicone dielectric grease (P/N 413 7017 00) in the regulator/rectifier 4-connector housing as well as the vehicle harness 4-connector housing and plug them together.

Ring Gear

Remove drive pulley. Refer to *Shop Manual* to perform drive pulley disassembly/assembly procedures and to proceed with pulley alignment.

Secure ring gear **no. 16** on inner half using 6 self tapping screws **no. 17**.

▼ CAUTION

Loctite 271 (red) must be applied on bolt threads to properly assemble the ring gear.

Torque screws to 27 N•m (20 lbf•ft) in a criss-cross sequence.

Do not reinstall drive pulley at this time.

Ignition Switch

Cut locking tie and unplug switch connector housing from ignition switch.

Install new ignition switch **no. 37**.

Insert the shortest wire of the fuse holder **no. 27** inside switch connector housing.

Insert connector in position number 7 on the switch-connector housing.

Reposition connectors respecting the vehicle connector code as illustrated.

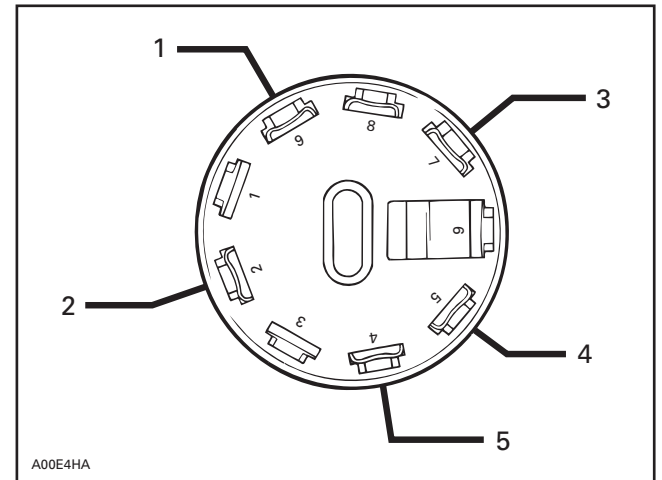

1. RED/GREEN wire to solenoid
2. BLACK/YELLOW
3. RED wire with fuse to battery
4. BLACK
5. RED/BLUE

Replug switch connector housing to ignition switch and secure wires with a locking tie **no. 28** as shown.

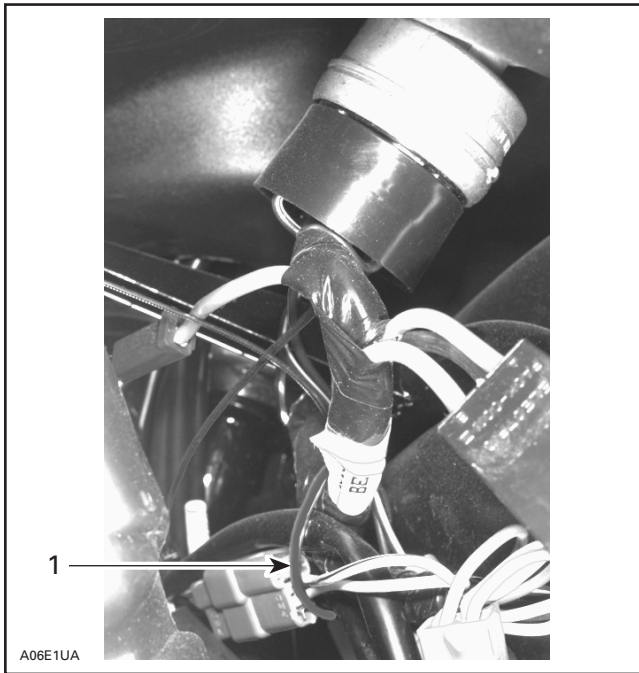

1. Locking tie

Wire/Cable Connections and Routing

Ensure one connector of the RED battery cable no. 22 is straight and other connector is bent at 60°. Bend or straighten as required.

The straight connector will be connected to the solenoid.

Starting from battery location, route battery positive cable along vehicle harness to the starter location. See following illustrations.

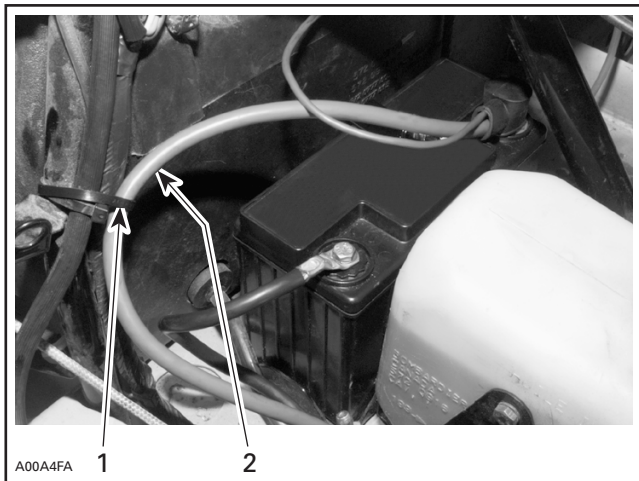

1. Secure with locking tie
2. RED positive cable routing

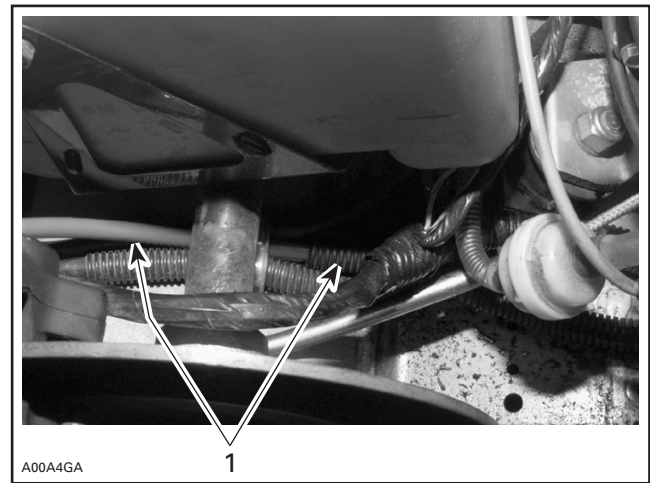

1. RED positive cable routing

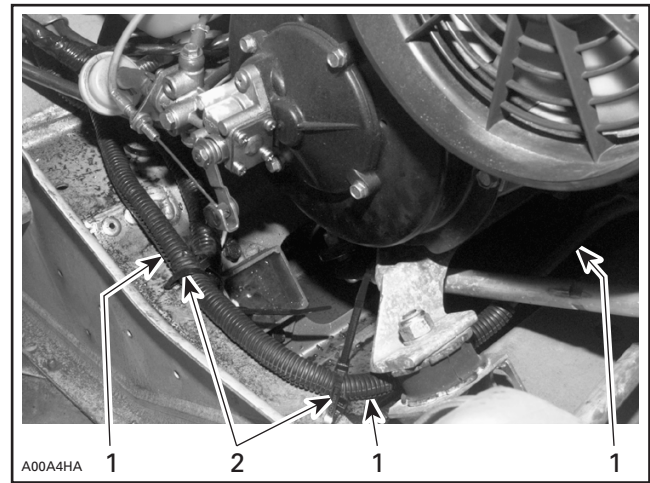

1. RED positive cable routing
2. Secure with locking ties

NOTE: Route battery cables through free bracket underneath countershaft.

Connect battery BLACK ground cable no. 20 to side of fan housing using self-tapping screw no. 38 and star washer no. 21. Refer to next photo.

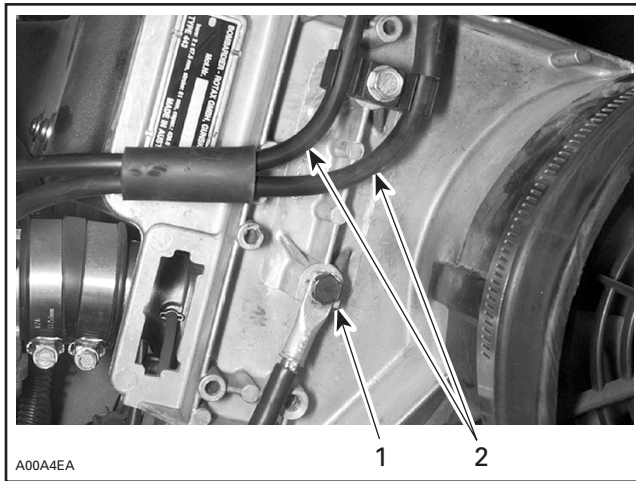

1. Connect battery ground cable here
2. Spark plug wires

Electric Starter

▼ CAUTION

Apply Loctite 271 (red) on all fastener threads of starter supports.

Secure starter support no. 3 (PTO side) to engine using socket screws no. 4 and lock washers no. 5. Tighten firmly.

Mount electric starter no. 8 on support. Secure bottom first and then the top using socket screws no. 6 and lock washers no. 7.

Install washers no. 11 over nuts of starter through bolts (MAG side).

Install starter support no. 9 (MAG side) to starter and secure with flanged elastic nuts no. 10.

If necessary, install hardened washer(s) no. 15 to fill the gap between the support and the engine. Secure support to the engine with washer no. 14, lock washer no. 13 and screw no. 12.

Install cable protector no. 34 then slide protector cap no. 23 onto RED battery cable no. 22. Install RED cable on starter with washer no. 26, lock washer no. 24 and nut no. 25. Bend connectors as required.

Cut the locking tie that is retaining the RED/GREEN wire to the wiring harness beneath engine.

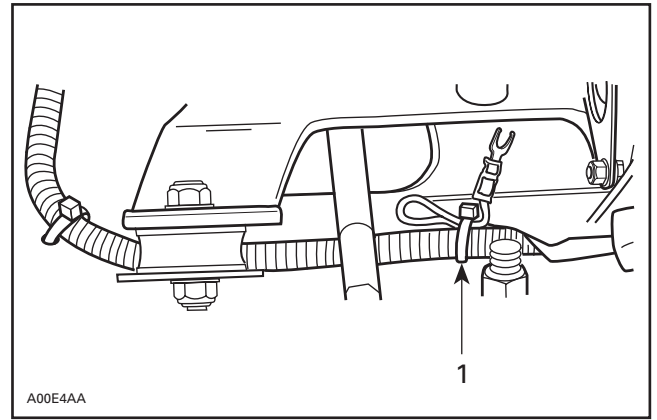

1. Cut locking tie

Connect RED/GREEN wire to the small post on solenoid. Position connector under lock washer.

Secure cables loosely to the rear bracket with a locking tie no. 28, as illustrated.

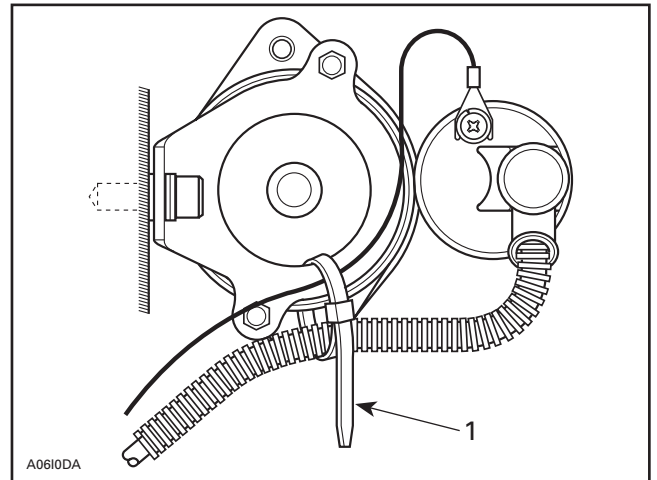

1. Tie loosely

Pull excess amount of cable from underneath engine.

Battery and Rack

▼ CAUTION

Cover carburetor intakes with a clean rag during the following drilling operation.

Remove oil reservoir from its support.

Remove reservoir support (keep the bolts for reinstallation), then the plate underneath it by drilling out retaining rivets.

Install support in a vice to bend to proper angle, refer to following illustration.

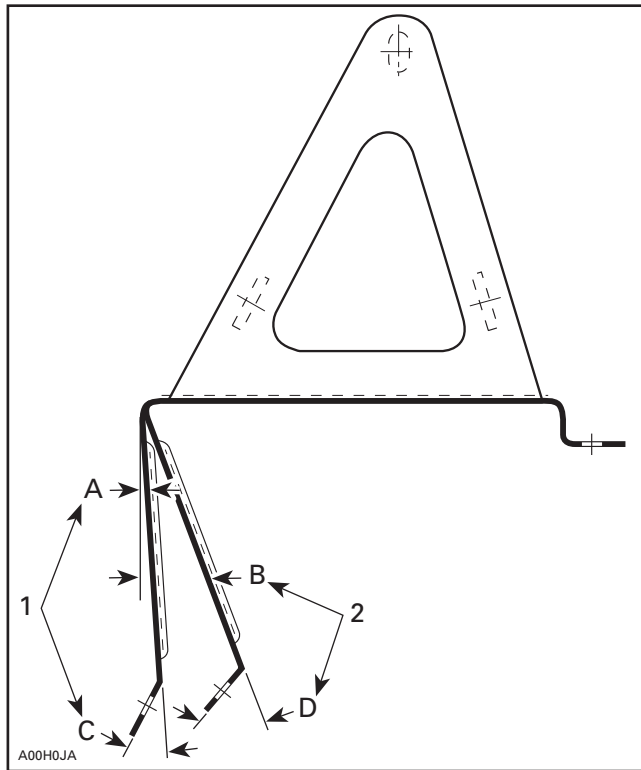

1. Original angles
2. New angles
- A. 4°
- B. 24°
- C. 31.6°
- D. 60°

Join battery seat **no. 18** to oil reservoir support using 2 rivets **no. 19**, making sure that support is mounted on top of battery seat.

Drill out battery vent fitting on body.

Install this assembly in place and secure, in same holes, by using previously removed oil reservoir support bolts.

At battery seat, use existing outer rivet hole as a first hole and drill two 5.2 mm (13/64 in) holes in body then secure with rivets **no. 19**.

Install rubber insulator **no. 30** and battery **no. 29** with positive post inside.

Secure battery in place with steel strips **no. 31**, using screw **no. 32** and flanged nut **no. 33**.

Insert protector cap **no. 23** onto red positive cable.

Connect battery RED positive cable and RED wire with fuse from ignition switch to battery post, upward angle, and tighten. Cover battery post with protector cap, then connect the BLACK ground cable and secure to battery post.

◆ WARNING

Always connect the battery cables exactly in the specified order. Connect RED positive cable first, then BLACK negative ground cable.

Fasten battery cables using a locking tie **no. 35**.

◆ WARNING

Ensure all terminals are properly crimped on wires/cables and that all connector housings are properly fastened. Keep wires away from any rotating, moving, heating or vibrating parts as well as from sharp edges. Use proper fastening devices as required.

FINALIZING INSTALLATION

NOTE: Refer to the *Ski-Doo Shop Manual* for proper reinstallation procedure.

Reinstall oil reservoir in its support.

Reinstall drive pulley.

Check pulley alignment.

◆ WARNING

Drive pulley alignment must always be checked whenever pulleys have been removed, replaced or disassembled.

Reinstall remaining removed parts.

Decal

Clean decal area with soapy water or isopropyl alcohol using a soft clean cloth and dry thoroughly.

▼ **CAUTION**

Do not apply isopropyl alcohol on decal.

Remove backing from decal.

Apply decal **no. 36** as shown.

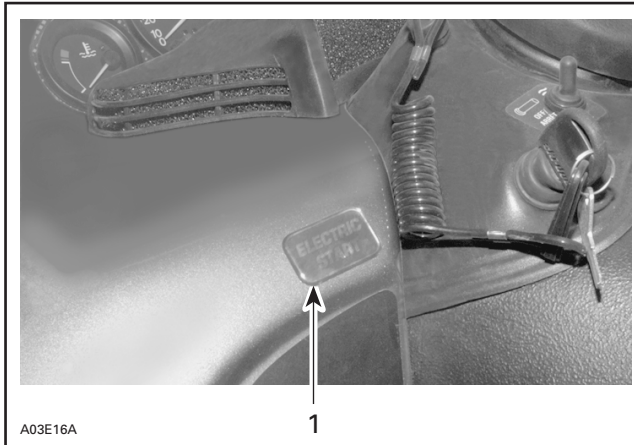

1. Decal

861 5042 00

1.	515 1639 00	Regulator/Rectifier	Régulateur/redresseur
2.	732 6000 02	Self-tapping Screw M6 x 16 (2)	Vis autotaraudeuse M6 x 16 (2)
3.	420 9516 92	Starter Support PTO	Support de démarreur (côté PDM)
4.	222 9820 65	Socket Screw M8 x 20 (2)	Vis à tête creuse M8 x 20 (2)
5.	420 9457 52	Lock Washer M8 (2)	Rondelle-frein M8 (2)
6.	222 9825 65	Socket Screw M8 x 25 (2)	Vis à tête creuse M8 x 25 (2)
7.	224 7811 40	Lock Washer M8 (2)	Rondelle-frein M8 (2)
8.	410 2124 00	Starter	Démarreur
9.	420 9517 02	Starter Support MAG	Support de démarreur (côté MAG)
10.	228 7510 45	Flanged Elastic Nut M5 (2)	Écrou d'arrêt élastique à épaulement M5 (2)
11.	391 3017 00	Flat Washer (2)	Rondelle plate (2)
12.	222 9820 65	Socket Screw M8 x 20	Vis à tête creuse M8 x 20
13.	420 9457 52	Lock Washer M8	Rondelle-frein M8
14.	224 0811 71	Flat Washer M8	Rondelle plate M8
15.	503 0079 00	Hardened Washer (2)	Rondelle trempée (2)
16.	415 0431 00	Ring Gear	Couronne de lancement
17.	732 6012 46	Self-tapping Screw M8 x 16 (6)	Vis autotaraudeuse M8 x 16 (6)
18.	517 3017 00	Battery Seat	Support de batterie
19.	390 4022 00	Rivet (5)	Rivet (5)
20.	515 1570 00	Battery Ground Cable (BLACK)	Câble de masse de la batterie (NOIR)
21.	394 0019 00	Star Washer	Rondelle en étoile
22.	515 1613 00	Battery Positive Cable (RED)	Câble positif de la batterie (ROUGE)
23.	570 1510 00	Protector Cap (2)	Capuchon de protection (2)
24.	420 9457 52	Lock Washer M8	Rondelle-frein M8
25.	228 0810 45	Hex. Nut M8	Écrou hexagonal M8
26.	224 0811 71	Flat Washer M8	Rondelle plate M8
27.	515 1573 00	Fuse Holder	Porte-fusible
28.	414 1152 00	Locking Tie (8)	Attache (8)
29.	410 3013 00	Battery	Batterie
30.	570 0703 00	Rubber Insulator	Bande isolante de caoutchouc
31.	517 3016 00	Steel Strip (2)	Bande d'acier (2)
32.	222 0516 65	Hex. Screw M5 x 16	Vis à tête hexagonale M5 x 16
33.	228 7510 45	Hex. Flanged Nut M5	Écrou hexagonal à épaulement M5
34.	414 6273 00	Protector	Gaine de protection
35.	748 0010 01	Locking Tie	Attache
36.	418 0013 00	Decal	Autocollant
37.	410 1113 00	Ignition Switch	Interrupteur d'allumage
38.	732 6011 20	Self-tapping Screw	Vis autotaraudeuse
39.	414 5806 00	Elbow Fitting (Not Illustrated)	Raccord coudé (non illustré)