



◆ **WARNING**

For safety reasons, this kit must be installed by an authorized Bombardier snowmobile dealer. Should removal of a locking device be required when undergoing disassembly/assembly, always replace with a new one. This instruction sheet should be given to the purchaser. This kit is designed for specific applicable models only. It is not recommended for vehicles other than those for which it was sold.

NOTE: Installation time is approximately 0.5 hour.

PARTS TO BE INSTALLED

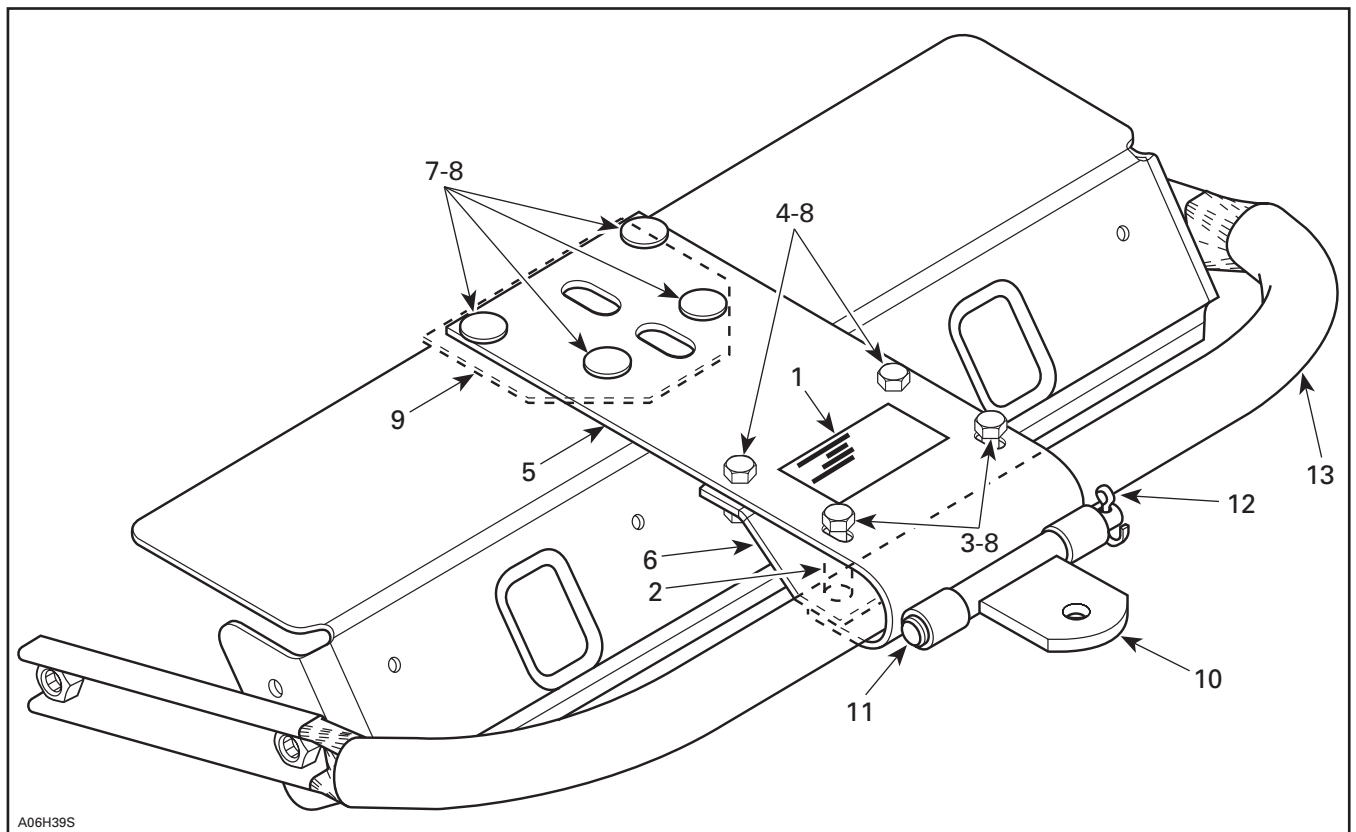

- | | |
|------------------------------|-----------------|
| 1. Label | 8. Nut M6 (8) |
| 2. Spacer (2) | 9. Inner Plate |
| 3. Bolt M6 x 50 (2) | 10. Hitch Plate |
| 4. Bolt M6 x 18 (2) | 11. Clevis Pin |
| 5. Support | 12. Cotter Pin |
| 6. Outer Plate | 13. Bumper |
| 7. Carriage Bolt M6 x 20 (4) | |

PROCEDURE

Remove seat (short tunnel model only).

Remove rear surrounding molding (if so equipped), or both rear side moldings (if so equipped).

Remove rear bumper.

Using the 4 pre-drilled holes in the end caps as guide, drill through the tunnel using a 6.5 mm (1/4 in) drill bit. See illustration.

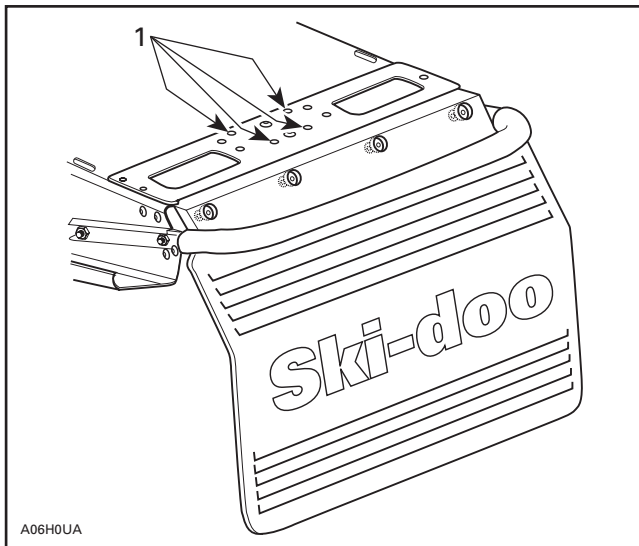

1. Pre-drilled holes

▼ CAUTION

Care must be taken to only drill in designated areas. Damage to the heat exchangers could occur if drilling outside this area.

CK-3 Models

Cut rear snowguard along inside guidelines to provide hitch opening.

For Z Models Only

Cut rear molding along inside guidelines to provide hitch opening.

All Models

Install new rear bumper **no. 13**.

Install outer plate **no. 6** with support **no. 5**, spacers **no. 2**, bolts **no. 3** and bolts **no. 4**. Secure with nuts **no. 8** and tighten.

Insert inner plate **no. 9** and support **no. 5** and secure with carriage bolts **no. 7** and nuts **no. 8**. Tighten all bolts.

Install hitch plate **no. 10** with clevis pin **no. 11** and cotter pin **no. 12**.

Reinstall rear molding(s) and seat.

NOTE: Make sure hitch plate swings freely on hitch bracket.

Affix warning label **no. 1** to hitch.

NOTE: A hook-type hitch kit (P/N 861 7225 00) is available for converting the present kit.

861 7649 00

1.	414 1329 00	Label	Étiquette
2.	517 1917 00	Spacer (2)	Entretoise (2)
3.	222 0650 65	Bolt M6 X 50 (2)	Boulon M6 x 50 (2)
4.	222 0618 65	Bolt M6 X 18 (2)	Boulon M6 x 18 (2)
5.	517 2947 00	Support	Support
6.	517 2948 00	Outer Plate	Plaque extérieure
7.	222 2620 65	Carriage Bolt M6 x 20 (4)	Boulon de carrosserie M6 x 20 (4)
8.	228 7610 45	Nut M6 (8)	Écrou M6 (8)
9.	517 2561 00	Inner Plate	Plaque intérieure
10.	517 0087 00	Hitch Plate	Plaque d'attelage
11.	505 0017 00	Clevis Pin	Axe de chape
12.	371 8002 00	Cotter Pin	Goupille fendue
13.	517 2438 00	Bumper	Pare-chocs