

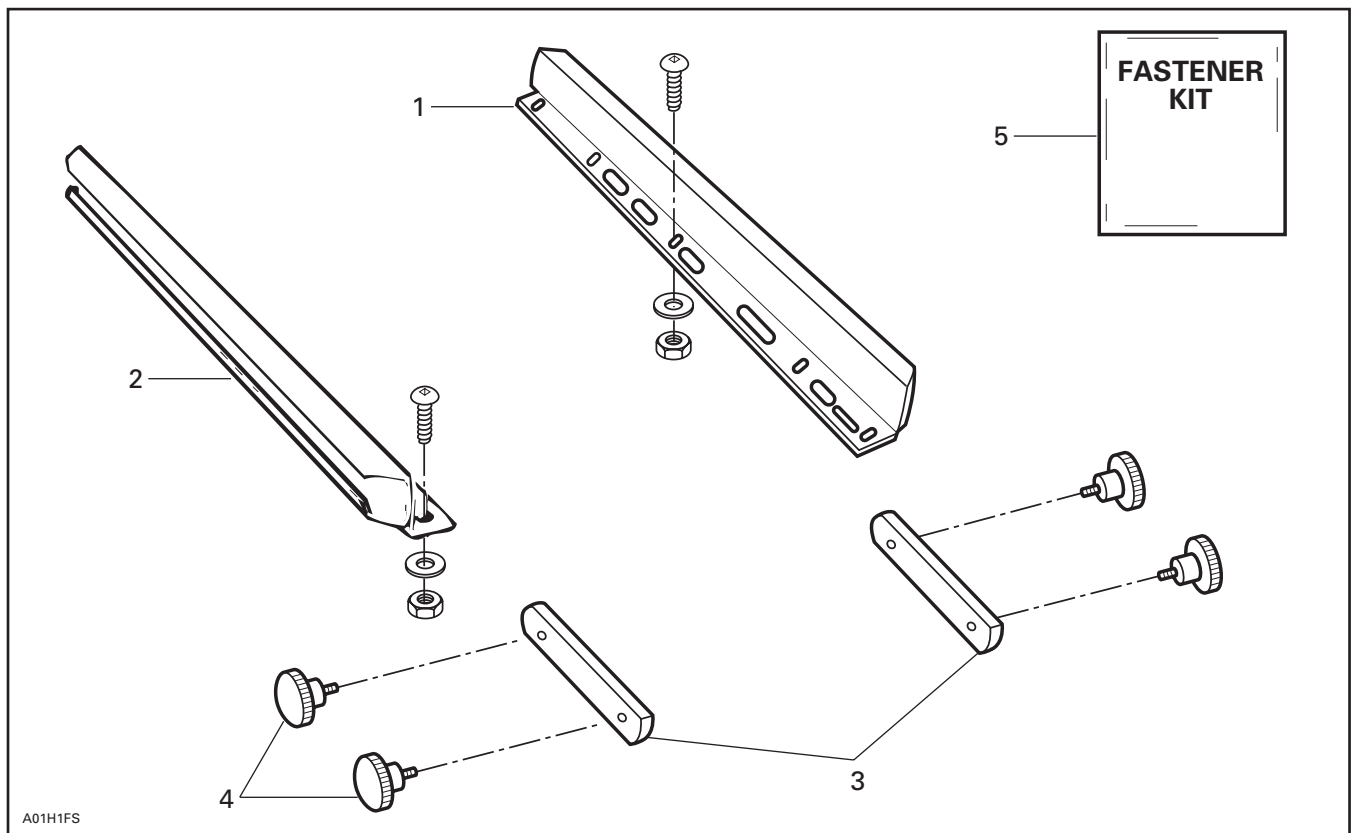

◆ **WARNING :** For safety reasons, this kit must be installed by an authorized Bombardier Ski-Doo snowmobile dealer. Should removal of a locking device be required when undergoing disassembly/assembly, always replace with a new one. This instruction sheet should be given to the purchaser after modification. This kit is designed for specific applicable models only. It is not recommended for snowmobiles other than those for which it was sold.

○ **NOTE :** Installation time is approximately 1.0 hour.

## PARTS TO BE INSTALLED



1. Rail, Right Side
2. Rail, Left Side
3. Sliding Plate (2)

4. Adjustable Knob (4)
5. Mounting Hardware (Bag containing Bolts, Washers and Nuts)

## INSTALLATION

Remove backrest and mounting brackets.

Remove seat from vehicle.

Lean left hand rail **no. 2** on tunnel so that the back of the steel angle is flush with edge of tunnel.

Install rail so that the slot aligns with the identical one on the tunnel.

Position recess at the end of the rail facing front of vehicle.

Hold rail firmly and using a punch, mark the slots on the tunnel for drilling references.

▼ **CAUTION** : When marking, align the punch in the center of the slot and at the outer edge to allow proper adjustment.

Drill holes in frame with a 6.5 mm (1/4 in) drill bit.

◆ **WARNING** : Be careful not to drill heat exchangers underneath frame.

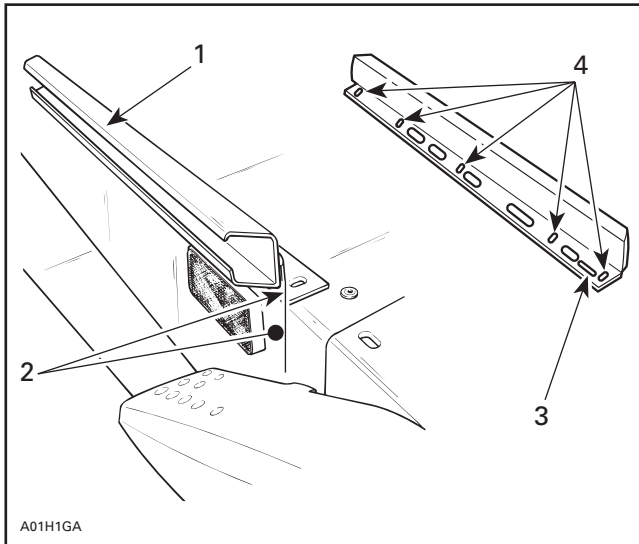

1. Slide of rail higher than tunnel
2. Flush with edge of tunnel
3. Slot to be aligned with identical one on tunnel
4. Slot for drilling references

Install rail with mounting hardware **no. 5**. Insert bolts from top and then washers and nuts from beneath.

Use the ratchet and extension for easy access beneath the tunnel. Tighten the nuts loosely for now.

Repeat procedure for the other side using right hand rail **no. 1**.

Pull out rails to prevent leatherette damage.

Reinstall seat (do not tighten) to adjust the rail distance accordingly.

Insert the sliding plates **no. 3** into the rails, the backrest onto rails and install the adjustable knobs **no. 4**. Tighten knobs loosely.

Slide the backrest forward and back to assure the rails are parallel and that the backrest movement is unobstructed.

Remove seat and tighten the bolts on each rail.

Slide the backrest frame forward and back again to assure easy movement.

Apply a light coat of grease on sliding surface of rails.

Reinstall seat.

Adjust backrest to desired position and tighten adjustable knobs.

◆ **WARNING** : Periodically check the adjustable knobs to assure that they are tight.

## 861 7553 00

➡	1.	415 0578 00	Rail, Right Side	Rail (côté droit)
➡	2.	415 0579 00	Rail, Left Side	Rail (côté gauche)
➡	3.	415 0698 00	Sliding Plate (2)	Plaque coulissante (2)
	4.	414 7183 00	Adjustable Knob (4)	Bouton réglable (4)
	5.	414 7362 00	Mounting Hardware (Bag containing Bolts, Washers and Nuts.)	Dispositifs de fixation (sac contenant les boulons, les rondelles et les écrous.)