



▼ CAUTION

For safety reasons, this kit must be installed by an authorized Bombardier snowmobile dealer. Should removal of a locking device be required when undergoing disassembly/assembly, always replace with a new one. This instruction sheet should be given to the purchaser. This kit is designed for specific applicable models only. It is not recommended for vehicles other than those for which it was sold.

NOTE: Installation time is approximately 0.4 hour.

PARTS TO BE INSTALLED

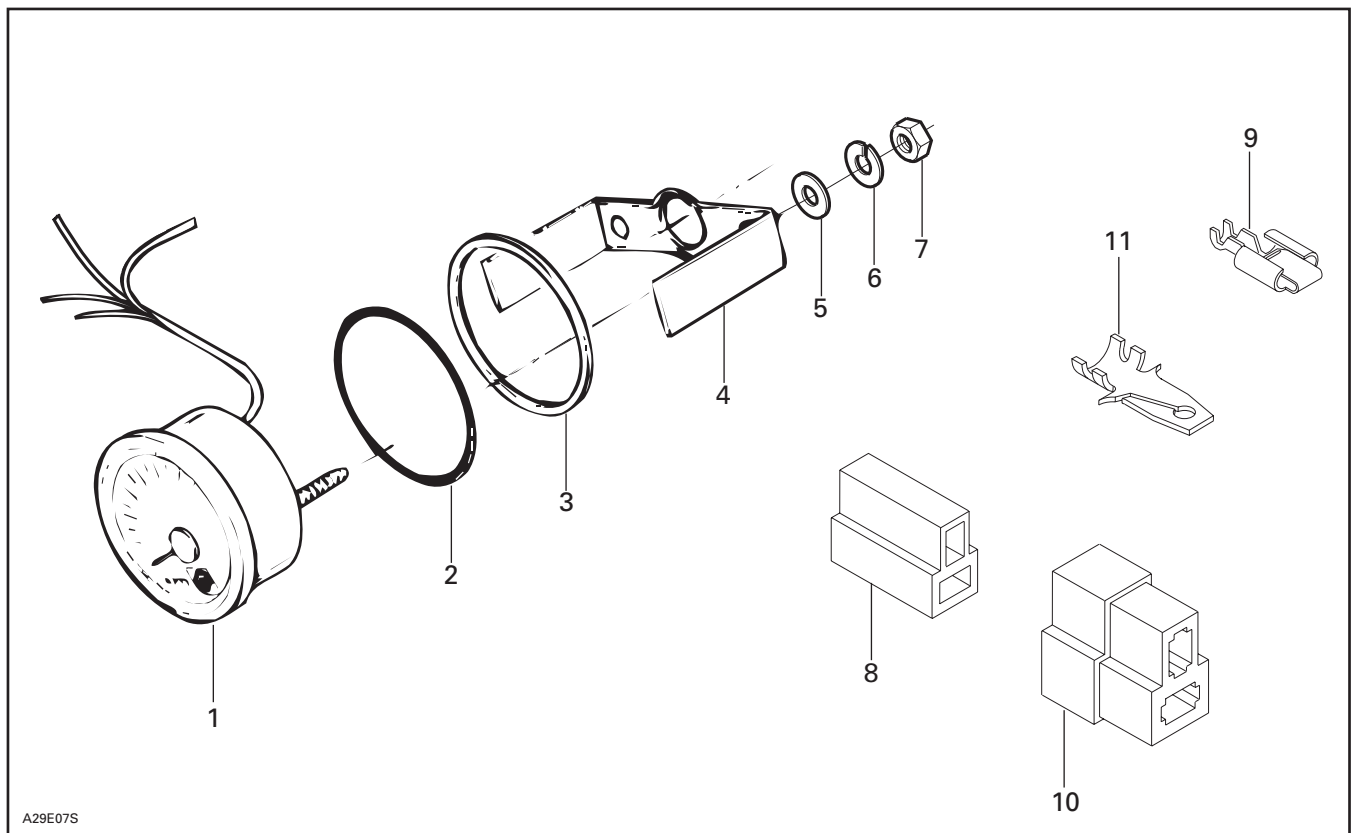

A29E07S

- | | |
|-----------------------|------------------------|
| 1. Tachometer | 7. Nut (2) |
| 2. Gauge Packing Ring | 8. Housing (2) |
| 3. Ring | 9. Female Connector(4) |
| 4. Housing Support | 10. Housing (2) |
| 5. Washers (2) | 11. Male Connector(4) |
| 6. Lock Washers (2) | |

INSTRUCTION

◆ WARNING

Always disconnect battery cables, if equipped, exactly in the specified order. Disconnect **BLACK** negative ground cable **first**, then **RED** positive cable.

Repeat the same procedure with the **YELLOW** wire and the **RED/YELLOW** wire from tachometer. Insert the 2 male connectors **no. 11** from tachometer into housing **no. 10**.

Using the template (page 3), drill a 110 mm (4-3/8 in) hole in the instrument panel.

Install gauge packing ring **no. 2** around the gauge **no. 1** then insert it in its hole.

Secure with the ring **no. 3**, the housing support **no. 4**, the flat washers **no. 5**, the lock washers **no. 6** and the nuts **no. 7**. Tighten firmly.

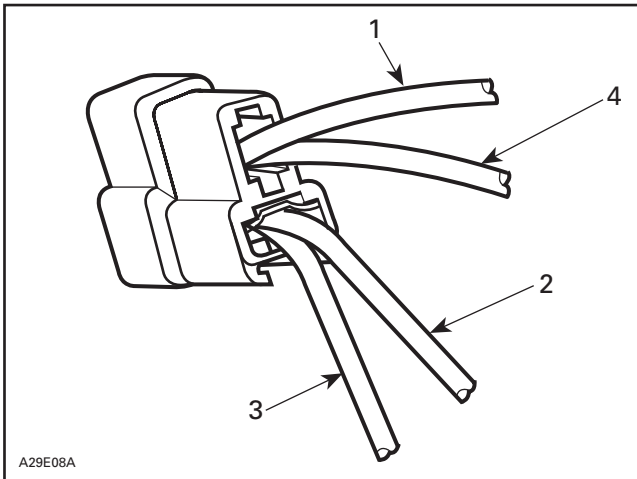

1. **YELLOW/BLACK**
2. **RED/YELLOW**
3. **YELLOW**
4. **GREEN**

Cut one piece of **YELLOW/BLACK** wire and one piece of **RED** wire to 660 mm (26 in) long. Use 18 gauge wires. (*Wires are not supplied with the kit.*)

Cut the wires to 330 mm (13 in.) to have 2 **YELLOW/BLACK** wires and 2 **RED** wires.

Install female connector **no. 9** to one end of each wire.

Insert 2 female connectors **no. 9**, (1 **YELLOW/BLACK** wire and 1 **RED** wire) into one housing **no. 8**. Repeat the same procedure using the other housing **no. 8**.

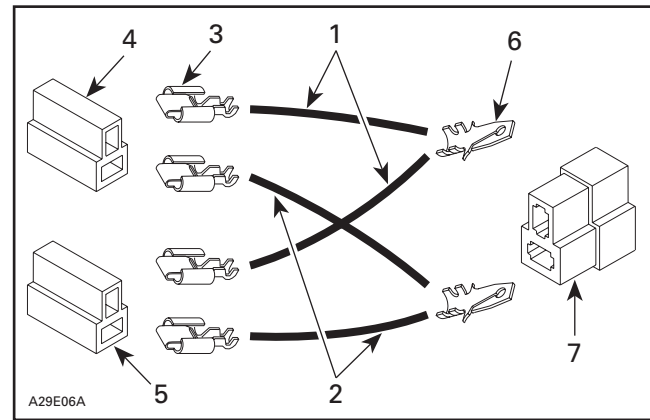

1. **YELLOW/BLACK** wires
2. **RED** wires
3. Female connectors
4. Housing A
5. Housing B
6. Male connectors
7. Housing C

Join other ends of **YELLOW/BLACK** wires together then install male connector **no. 11**. Repeat the same procedure with the **RED** wires.

Insert the 2 male connectors **no. 11** into housing **no. 10**.

INSTALLATION

Unplug connector housing from speedometer.

Connect housing A to speedometer.

Connect housing B to tachometer.

Connect housing C to vehicle wiring harness.

Verify that both gauges operate properly.

◆ WARNING

Always connect the battery cables, if equipped, exactly in the specified order. Connect **RED** positive cable **first** then **BLACK** negative ground cable.

DRILLING TEMPLATE

Use this template to properly drill the hole in the dashboard.

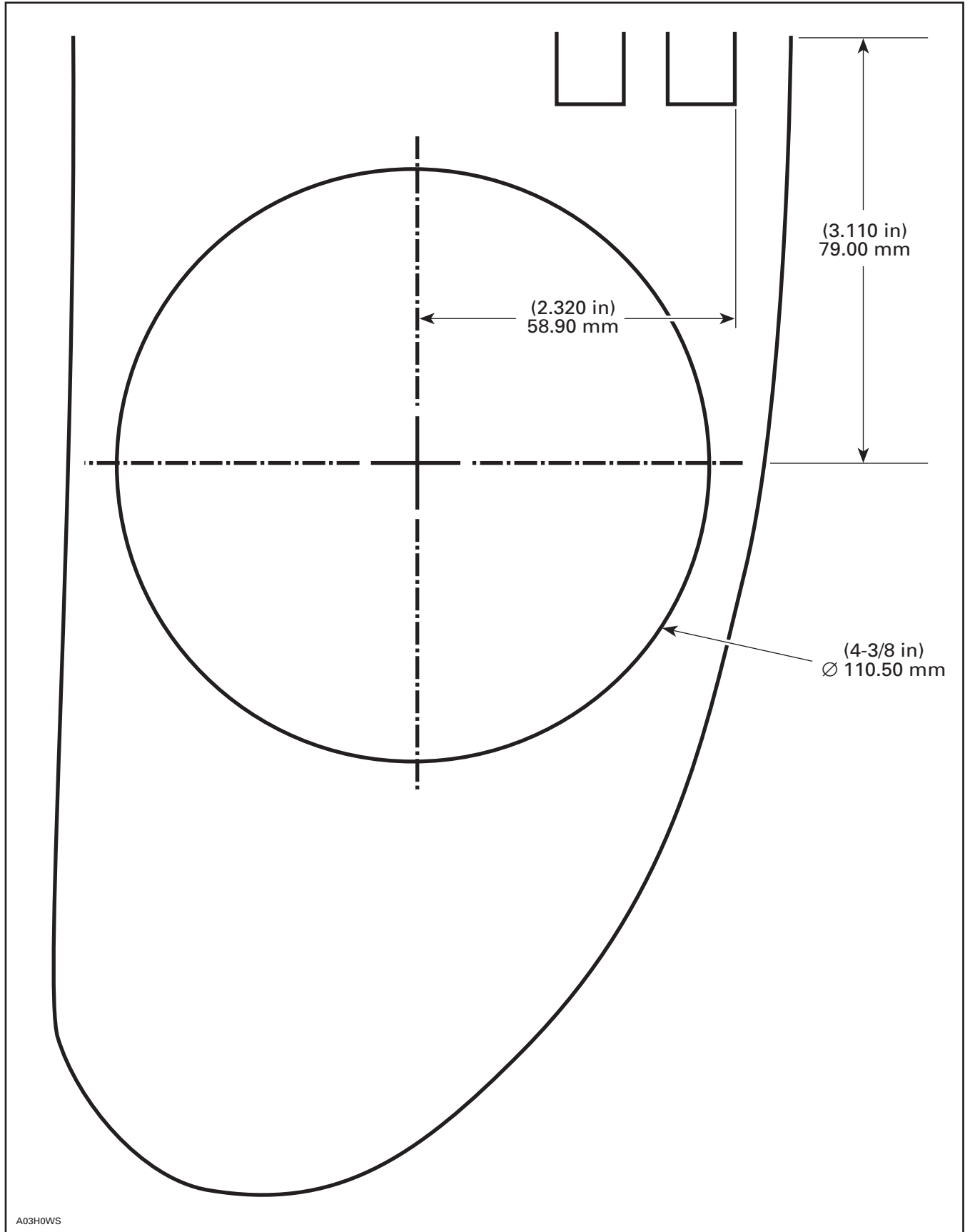

861 7591 00

1.	414 8074 00	Tachometer	Tachymètre
2.	414 8071 00	Gauge Packing Ring	Joint torique
3.	517 2585 00	Ring	Anneau
4.	414 8065 00	Housing Support	Support d'indicateur
5.	414 8068 00	Washer (2)	Rondelle (2)
6.	414 8067 00	Lock Washer (2)	Rondelle-frein (2)
7.	414 8069 00	Nut (2)	Écrou (2)
8.	409 2046 00	Housing (2)	Logement (2)
9.	561 5031 00	Female Connector (4)	Raccord femelle (4)
10.	409 2045 00	Housing (2)	Logement (2)
11.	561 5034 00	Male Connector (4)	Raccord mâle (4)