



◆ **WARNING**

For safety reasons, this kit must be installed by an authorized Bombardier Ski-Doo snowmobile dealer. Should removal of a locking device be required when undergoing disassembly/assembly, always replace with a new one. This instruction sheet should be given to the purchaser after modification. This kit is designed for specific applicable models only. It is not recommended for snowmobiles other than those for which it was sold.

NOTE: Installation time is approximately 1.0 hour.

PARTS TO BE INSTALLED

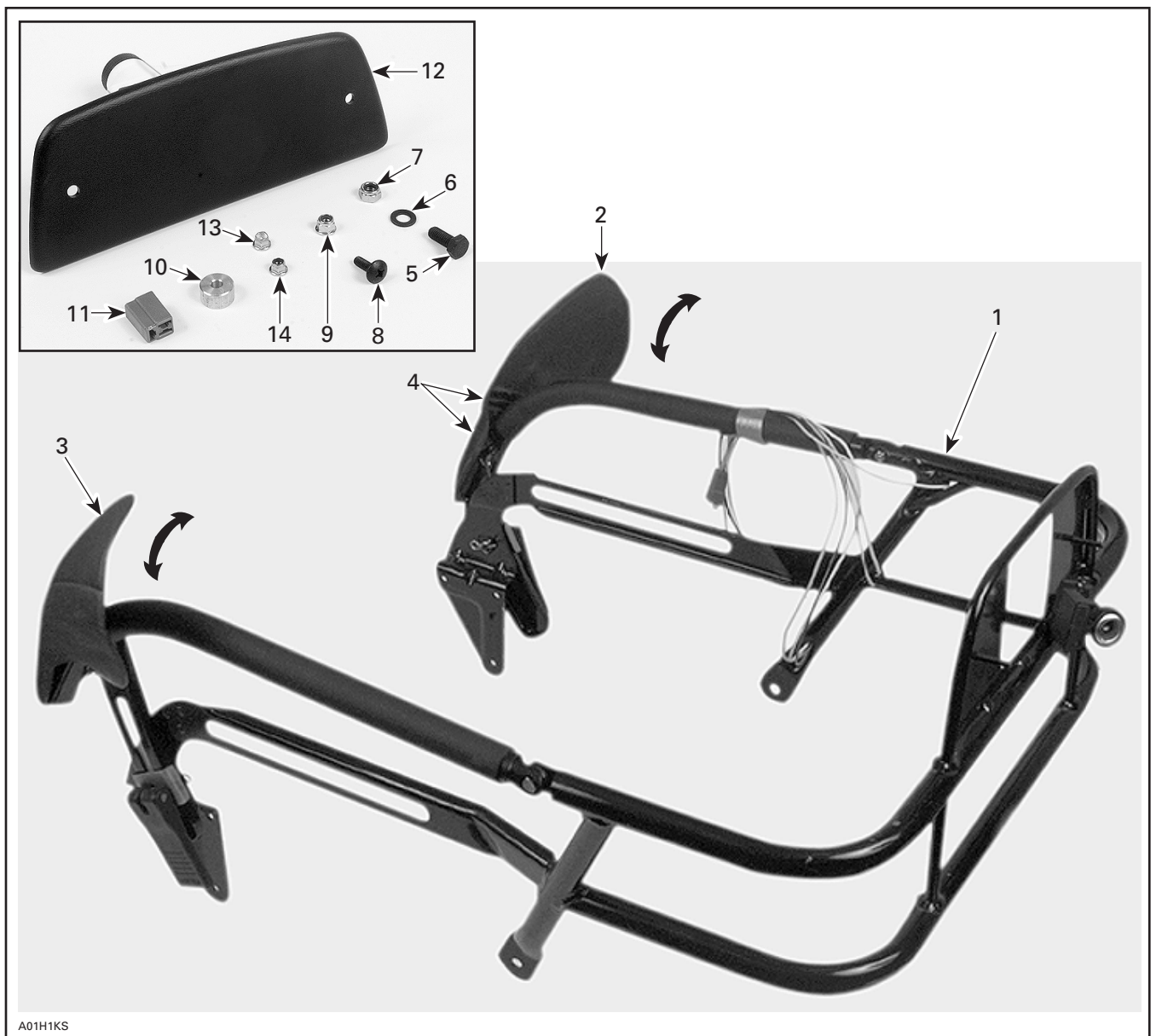

A01H1KS

1. Luggage Rack Assy
2. Protector RH (Not Installed)
3. Protector LH (Not Installed)
4. Rivet (4)
5. Hex Bolt M8 X 20 (2)
6. Flat Washer (2)
7. Elastic Flanged Nut M8 (2)

8. Screw-Taptite M6 X 18 (6)
9. Elastic Flanged Nut M6 (6)
10. Spacer (2)
11. Connector Housing
12. Plastic Cover
13. Dome Nut M5 (2)
14. Elastic Flanged Nut M5 (2)

VEHICLE PREPARATION

Remove the tail light assembly from the seat. Keep the screws, nuts and washers.

Remove seat and moldings.

Remove the tab connectors from the tail light connector block.

Remove staples 300 mm (1 foot) in length from the right rear corner and moving forward along the side of the seat.

Remove staples 140 mm (5-1/2 in) in length from rear of seat.

INSTALLATION

Drill a 25 mm (1 in) hole in bottom of seat.

Refer to the following illustration.

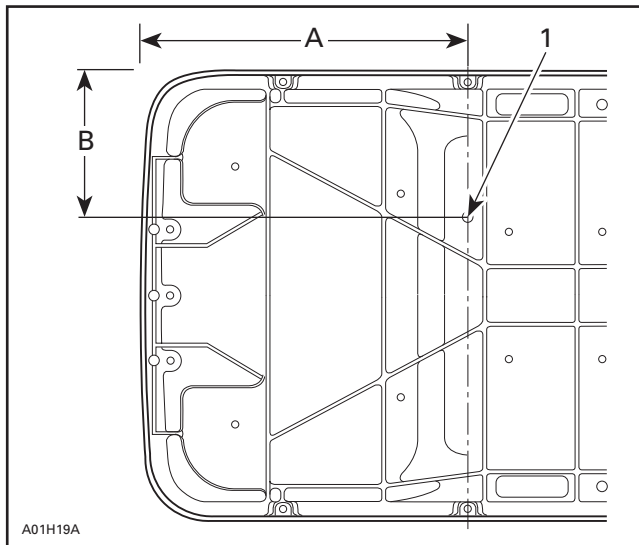

1. Drill hole here
- A. 300 mm (1 foot)
- B. 140 mm (5-1/2 in)

Reroute the tail light harness to the previously drilled hole by passing it through the foam in the seat.

NOTE: Remove more staples if required for easier access.

Pull the harness through the hole then install the connector housing **no. 11**. Be sure to match the proper wire colors by referring to the colors of the connector at the front of the seat.

Restaple the seat cover.

Install the spacers **no. 10**, plastic cover **no. 12** and dome nuts **no. 13** on the seat in the previous tail light location. If necessary, install washers (P/N 517 1243 00), not supplied in this kit.

Tail Light Housing Preparation

Remove bulb light from original light connector on the tail light housing. Keep it.

Pull out reflector from tail light housing, and keep it.

Remove the short wires between the light connector and the tail light housing. Discard short wires.

Remove light connector from tail light housing. Discard light connector.

For models with a plastic clip on the right side of the tail light housing, use a pair of side cutters and cut it. Only cut the plastic clip, as shown in the following illustration.

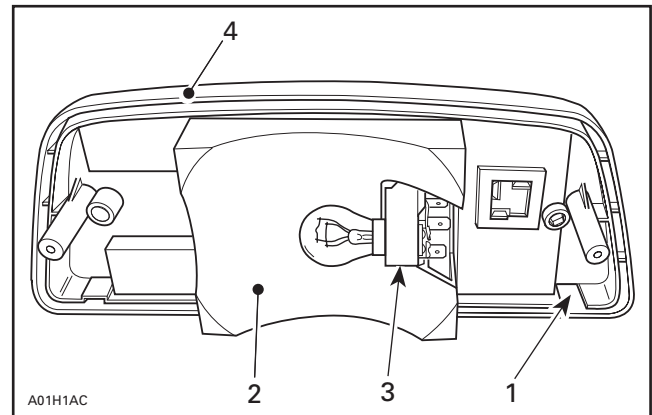

1. Cut here
2. Pull out reflector
3. Remove light connector and discard it
4. Tail light housing

Position new light connector on tail light housing.

Reinstall original reflector over new light connector and clip it on tail light housing.

Route wires through the previously cut tail light housing, as shown on the next photo.

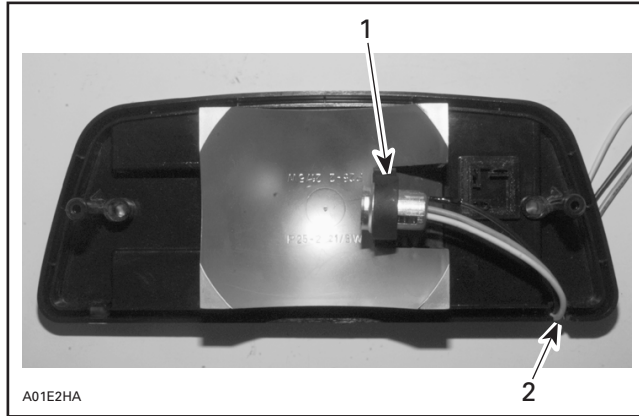

1. New light connector installed
2. Route wires here

Reinstall original tail light bulb.

Reinstall the tail light housing on the rack using the welded screws, elastic flanged nuts **no. 14** and washers that were previously removed.

Reinstall lens on tail light housing with original screws.

Luggage Rack Installation

Locate the rear hole on each side of the tunnel as illustrated and drill 8.5 mm (21/64 in) hole, if necessary.

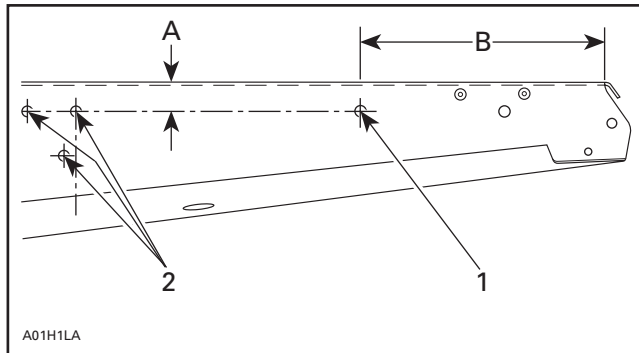

1. Rear hole 8.5 mm (21/64 in)
2. 6.5 mm (1/4 in) holes
- A. 25 mm (1 in)
- B. 170 mm (6-51/64 in)

Install the rear mounts of the luggage rack **no. 1** on the vehicle with bolts **no. 5**, flat washers **no. 6** and elastic flanged nuts **no. 7**. Hand tighten.

Lean the rack forward until the two upper holes are 25 mm (1 in) from the top of the tunnel and drill three 8.5 mm (21/64 in) holes through the tunnel as well as the tunnel reinforcement on each side.

▼ CAUTION

Use extreme caution when drilling, do not pierce heat exchangers. Use a thin block of wood as a backing plate when drilling.

Install screws **no. 8** and elastic flanged nuts **no. 9**. Do not tighten yet.

Position Left Hand protector **no. 3** and Right Hand protector **no. 2** in front of adjustable handle bar.

Install protectors with rivets **no. 4**, in existing holes.

Plug the tab connectors for the tail light.

Reinstall the seat assuring that the connectors are properly tucked into the seat and that there is no gap between the seat and the top of the tunnel.

Firmly tighten the seat and the luggage rack.

Cut the moldings to fit around the rack tubes.

Reinstall the moldings.

Test the tail light and the brake light for proper operation.

861 7582 00

1.	580 6571 00	Luggage Rack Assy	Porte-bagages (complet)
2.	572 0894 00	Protector (LH)	Protecteur (droit)
3.	572 0895 00	Protector (RH)	Protecteur (gauche)
4.	390 9077 00	Rivet (4)	Rivet (4)
5.	732 6011 86	Hex Bolt M8 X 20 (2)	Boulon hexagonal M8 X 20 (2)
6.	732 9000 30	Flat Washer (2)	Rondelle plate (2)
7.	228 5810 45	Elastic Flanged Nut M8 (2)	Écrou à épaulement élastique M8 (2)
8.	732 6000 09	Screw-Taptite M6 X 18 (6)	Vis autotaraudeuse M6 X 18 (6)
9.	228 7610 45	Elastic Flanged Nut M6 (6)	Écrou à épaulement élastique M6 (6)
10.	409 2043 00	Connector Housing	Logement de raccords
11.	517 2236 00	Spacer (2)	Entretoise (2)
12.	414 9765 00	Plastic Cover	Couvercle de plastique
13.	732 6100 62	Dome Nut M5 (2)	Écrou-capuchon M5 (2)
14.	228 7510 45	Elastic Flanged Nut M5 (2)	Écrou à épaulement élastique M5 (2)