



◆ WARNING

For safety reasons, this kit must be installed by an authorized Bombardier Ski-Doo snowmobile dealer. Should removal of a locking device be required when undergoing disassembly/assembly, always replace with a new one. This instruction sheet should be given to the purchaser after modification. This kit is designed for specific applicable models only. It is not recommended for snowmobiles other than those for which it was sold.

NOTE: Installation time is approximately 1.0 hour.

PARTS TO BE INSTALLED

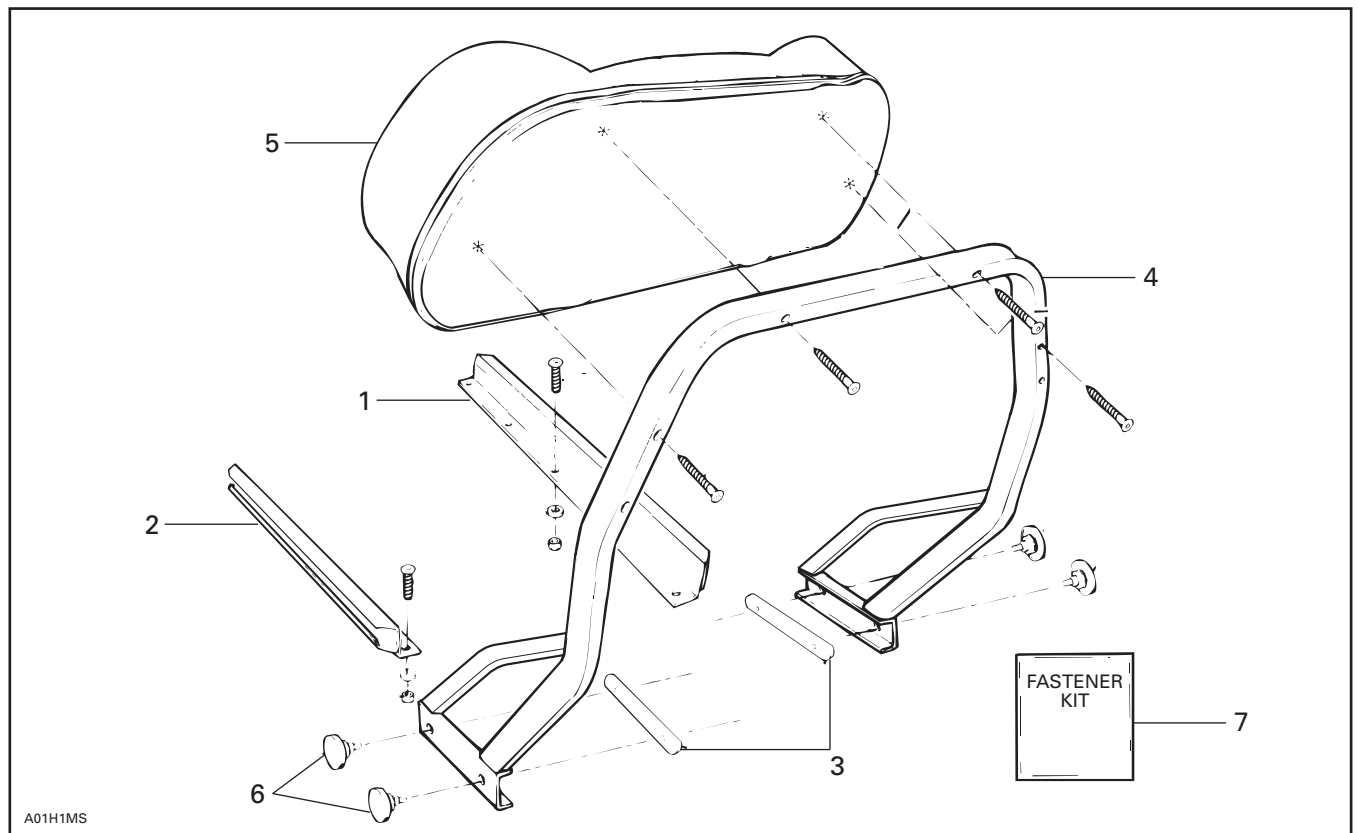

1. Rail, Right Side
2. Rail, Left Side
3. Sliding Plate (2)
4. Backrest Frame

5. Cushion
6. Adjustable Knob (4)
7. Mounting Hardware (Bag containing Screws, Washers, Nuts and Wood Screws)

INSTALLATION

Remove seat from vehicle.

Lean left hand rail **no. 2** on tunnel so that the back of the steel angle is flush with edge of tunnel.

Install rail so that the slot aligns with the identical one on the tunnel.

Position recess at the end of the rail facing front of vehicle.

Hold rail firmly and using a punch, mark the slots on the tunnel for drilling references.

▼ CAUTION

When marking, align the punch in the center of the slot and at the outer edge to allow proper adjustment.

Drill holes in frame with a 6.5 mm (1/4 in) drill bit.

◆ WARNING

Be careful not to drill radiators underneath frame.

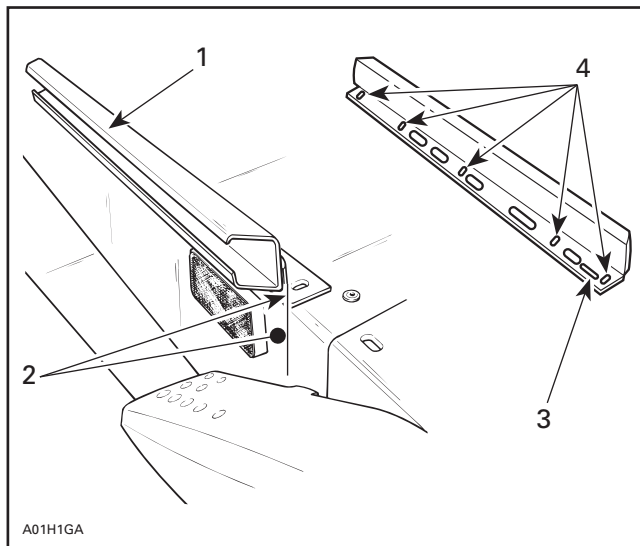

1. Slide of rail higher than tunnel
2. Flush with edge of tunnel
3. Slot to be aligned with identical one on tunnel
4. Slots for drilling references

Install rail with mounting hardware **no. 7**. Insert screws from top and then washers and nuts from beneath.

NOTE: Wood screws from the mounting hardware bag will be used later in the installation.

Use the ratchet and extension for easy access beneath the tunnel. Tighten the nuts loosely for now.

Repeat procedure for the other side using right hand rail **no. 1**.

Reinstall seat (do not tighten) to adjust the rail distance accordingly.

Insert the sliding plates **no. 3** into the rails, the backrest frame **no. 4** onto rails and install the adjustable knobs **no. 6**. Tighten knobs loosely.

Slide the backrest frame forward and back to assure the rails are parallel and that the backrest movement is unobstructed.

Remove seat and tighten the bolts on each rail.

Slide the backrest frame forward and back again to assure easy movement.

IMPORTANT: Adjust backrest width prior to installing cushion.

NOTE: If the luggage rack and the backrest are to be installed at the same time, proceed with rack installation before installing cushion.

Position the cushion **no. 5** on the backrest frame so that it is centered both from side to side and top to bottom.

NOTE: Make sure to keep at least 16 mm (5/8 in) on top so that if a luggage rack is installed, the top of the cushion will be flush with the top of the rack's transverse bar.

Secure cushion with wood screws included in bag **no. 7**.

Apply a light coat of grease on sliding surface of rails.

Adjust backrest to desired position and tighten adjustment knobs.

Reinstall seat.

◆ WARNING

Periodically check the adjustment knobs to assure that they are tight.

861 7587 00

1.	415 0578 00	Rail, Right Side	Rail (côté droit)
2.	415 0579 00	Rail, Left Side	Rail (côté droit)
3.	414 7359 00	Sliding Plate (2)	Plaque coulissante (2)
4.	414 7360 00	Backrest Frame	Châssis de dossier
5.	414 7361 00	Cushion	Coussin
6.	414 7183 00	Adjustable Knob (4)	Bouton réglable (4)
7.	414 7362 00	Mounting Hardware (Bag containing Screws, Washers, Nuts and Wood Screws)	Dispositifs de fixation (sac contenant les vis, les rondelles, les écrous et les vis à bois)