

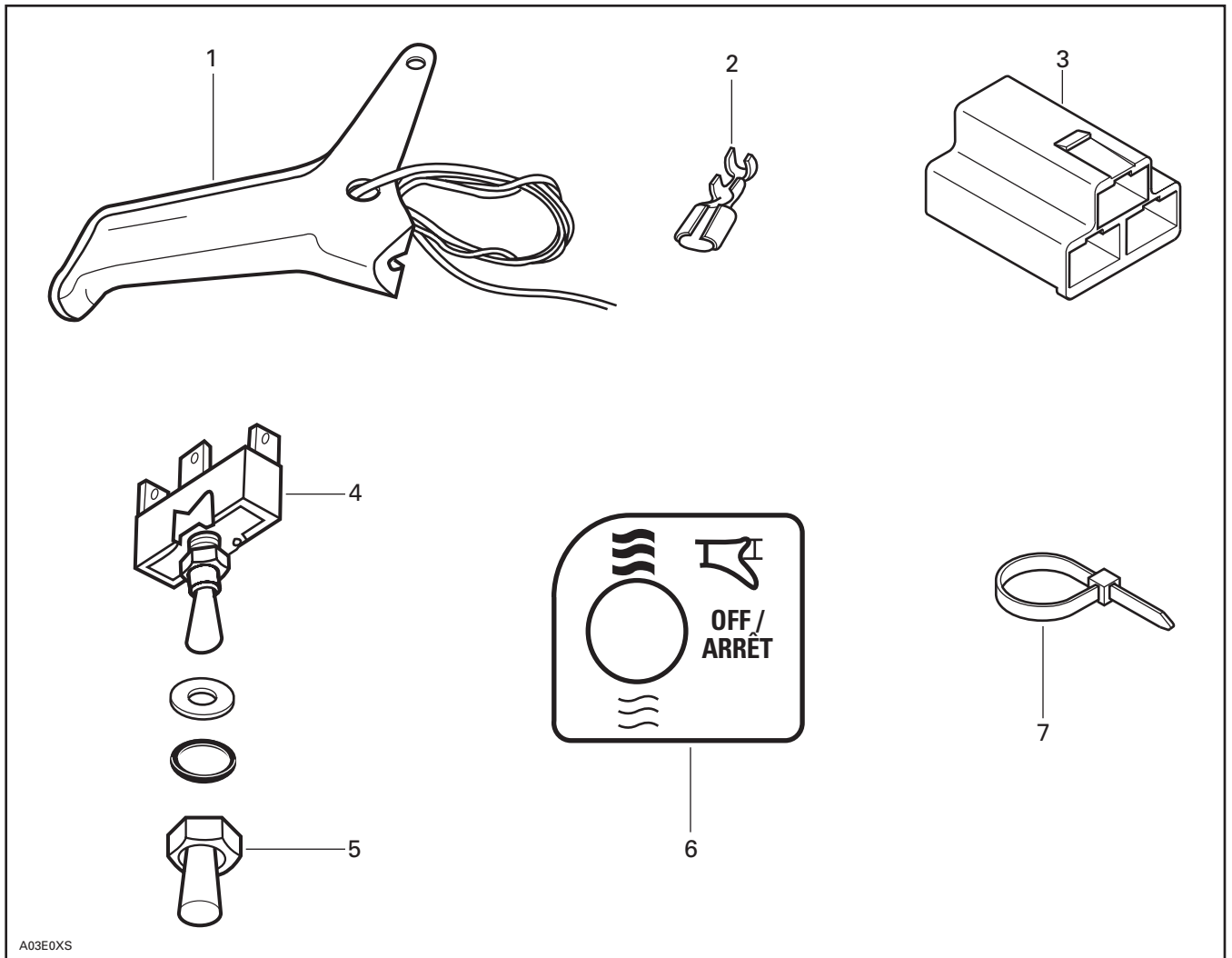

◆ **WARNING :** For safety reasons, this kit must be installed by an authorized Bombardier snowmobile dealer. Should removal of a locking device be required when undergoing disassembly / assembly, always replace with a new one. This instruction sheet should be given to the purchaser. This kit is designed for specific applicable models only. It is not recommended for vehicles other than those for which it was sold.

○ **NOTE :** Installation time is approximately 1.0 hour.

PARTS TO BE INSTALLED



- 1. Heating Throttle Lever
- 2. Female Connector (3)
- 3. 3-Connector Housing
- 4. Heater Switch

- 5. Switch Cover
- 6. Decal
- 7. Locking Tie (3)

INSTRUCTIONS

◆ **WARNING** : Always disconnect battery cables, if equipped, exactly in the specified order. Disconnect **BLACK** negative ground cable **FIRST**, then **RED** positive cable.

Remove the steering cover and the throttle lever then disconnect throttle cable.

Drill a 6.0mm (1/4 in) hole on the bottom side of the throttle housing as shown.

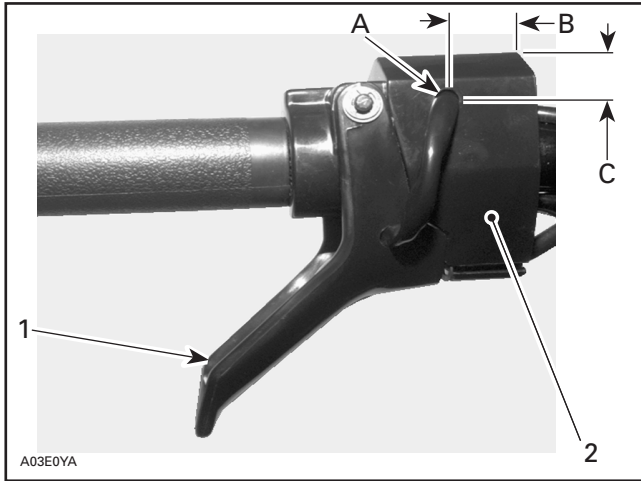

- 1. Heating throttle lever
- 2. Throttle housing
- A. Drill hole 6.0mm (1/4 in)
- B. 14.5 mm (9/16 in)
- C. 14.5 mm (9/16 in)

Insert the heating throttle wires in the throttle housing through the side wire hole.

○ **NOTE** : Throttle housing cover can be loosened to ease drilling and routing of wires.

Install throttle cable on the new heating throttle **no. 1**.

Connect the new heating throttle on the throttle housing.

▼ **CAUTION** : Make sure wires do not interfere with throttle lever operation.

Route the wires through the retaining support in front of the steering column.

Cut existing locking tie and install new locking tie **no. 7** as shown in the next photo.

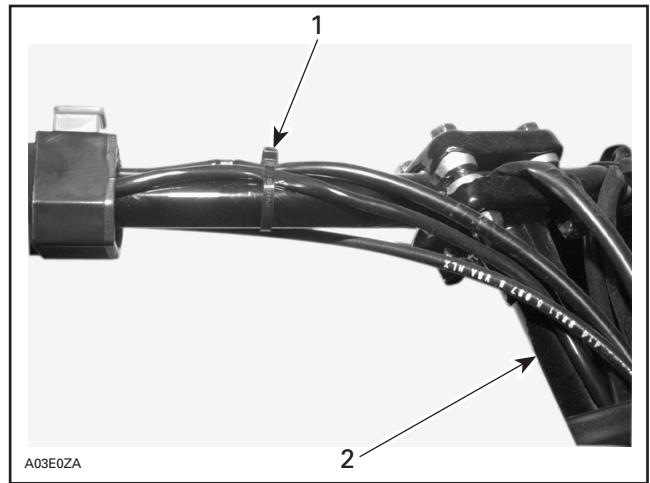

- 1. Locking tie
- 2. Steering column

Remove the console screws and the RH cap from console.

Heat the console in the decal region with a portable propane torch. Continue to apply heat until the plastic surface of the console has a wet look .

◆ **WARNING** : Prior to using the propane torch, remove all flammable items that could ignite. Apply heat using caution.

Apply decal **no. 6** on plastic surface.

Install the switch **no. 4** in the hole and secure with switch cover **no. 5**.

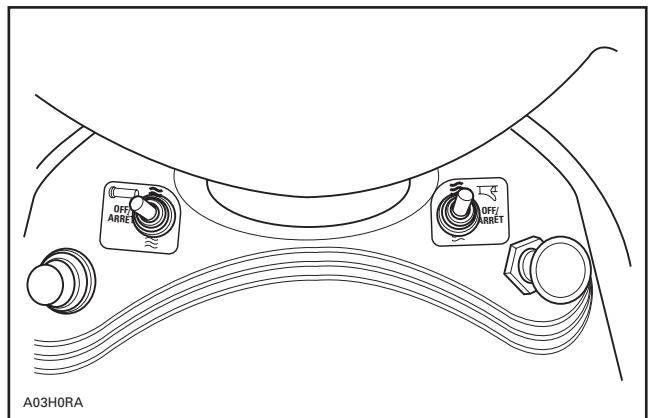

- 1. Heating switch

Install female connectors **no. 2** on the heating throttle wires then insert in the 3-connector housing **no. 3** respecting the vehicle connector colour code.

Throttle Harness	Vehicle Harness
BROWN	BROWN
BROWN / YELLOW	BROWN / YELLOW
YELLOW / BLACK	YELLOW / BLACK

Connect the 3-connector housing of the heating throttle to the corresponding 3-connector housing of the vehicle.

Route the switch wires from behind the steering column to the heater switch.

NOTE: The switch wires (YELLOW, BROWN, YELLOW / BROWN) are already routed to the LH side of steering column.

Connect switch wires as illustrated.

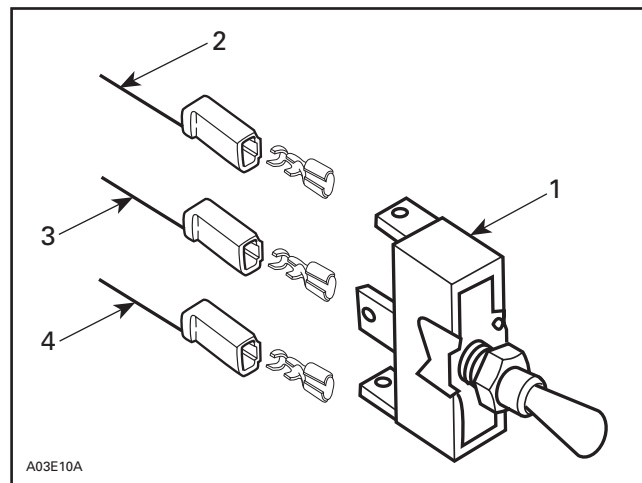

1. Heater switch
2. BROWN / YELLOW wire (low)
3. YELLOW wire
4. BROWN wire (high)

Install locking ties **no. 7** on steering support and main wiring harness as shown in the next photo.

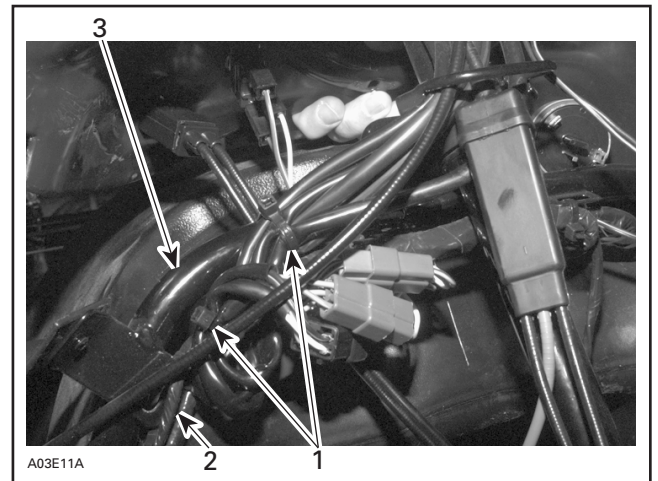

1. Locking ties (2)
2. Main wiring harness
3. Steering support

WARNING: Ensure all connectors are properly crimped on the wires and that all connector housings are properly fastened. Keep wires away from any rotating, moving, heating or vibrating parts. Use proper fastening devices as required.

Reconnect the battery, if equipped.

Reinstall console screws and steering cover.

Adjust throttle housing and tighten screw.

WARNING: Always connect the battery cables, if equipped, exactly in the specified order. Connect RED positive cable FIRST, then BLACK negative ground cable.

Test operation of the throttle heater on both low and high positions.

861 7558 00

1.	572 0845 00	Heating Throttle Lever	Manette d'accélérateur chauffante
2.	561 5032 00	Female Connector (3)	Raccord femelle (3)
3.	409 0085 00	3-Connector Housing	Logement à 3 raccords
4.	410 1073 00	Heater Switch	Interrupteur de manette d'accélérateur chauffante
5.	570 0139 00	Switch Cover	Couvercle d'interrupteur
6.	414 8984 00	Decal	Autocollant
7.	414 1152 00	Locking Tie (3)	Attache (3)