

ski-doo®

1997
VOLUME 3

SHOP MANUAL



**FORMULA III / III LT
MACH 1 / Z / Z LT**

4 8 4 0 6 4 7 0 2



ski-doo®

1997
Shop Manual

VOLUME 3

FORMULA III/III LT

MACH 1/Z/Z LT



Legal deposit:

National Library of Quebec
3rd trimester 1996
National Library of Canada 1996

All rights reserved. No parts of this manual may be reproduced in any form without the prior written permission of Bombardier Inc.

©Bombardier Inc. 1996

Technical Publications
Bombardier Inc.
Valcourt (Quebec) Canada

Printed in Canada

®*Registered trademarks of Bombardier Inc.

This document contains the trademarks of the following companies:

Loctite® is a trademark of Loctite Corporation

Metton® is a trademark of Hercules Inc.

Molykote® is a trademark of Dow Corning Corporation

Silastic® is a trademark of Dow Corning Corporation

Snap-on® is a trademark of Snap-on Tools Corporation

Versilube® is a trademark of General Electric Company

Supertanium™ is a trademark of Premier Industrial Corporation

TABLE OF CONTENTS

SECTION	SUB-SECTION	PAGE
	SAFETY NOTICE	V
	1997 BOMBARDIER SNOWMOBILES SHOP MANUAL VOLUME 3 (INTRODUCTION)	VI
01	LUBRICATION AND MAINTENANCE	
	01 – Lubrication and maintenance chart	01-01-1
02	TROUBLESHOOTING	
	01 – Table of contents.....	02-01-1
	02 – Engine	02-02-1
	03 – Fuel and oil systems.....	02-03-1
	04 – Transmission and brake systems	02-04-1
	05 – Electrical system	02-05-1
	06 – Suspension system and track	02-06-1
03	ENGINE	
	01 – Table of contents.....	03-01-1
	02 – 599, 699 and 809 engine types.....	03-02-1
	03 – Leak test and engine dimension measurement	03-03-1
	04 – CDI system.....	03-04-1
	05 – Oil injection system.....	03-05-1
	06 – Liquid cooling system.....	03-06-1
	07 – Rewind starter.....	03-07-1
	08 – Carburetor and fuel pump	03-08-1
	09 – Fuel tank and throttle cable	03-09-1
04	TRANSMISSION	
	01 – Table of contents.....	04-01-1
	02 – Drive belt	04-02-1
	03 – Drive pulley.....	04-03-1
	04 – Driven pulley.....	04-04-1
	05 – Pulley distance and alignment.....	04-05-1
	06 – Brake	04-06-1
	07 – Chaincase	04-07-1
	08 – Drive chain.....	04-08-1
05	ELECTRICAL	
	01 – Table of contents.....	05-01-1
	02 – Wiring diagrams (see Annexes at the end of this manual).....	05-02-1
	03 – Ignition timing.....	05-03-1
	04 – Spark plugs.....	05-04-1
	05 – Testing procedure	05-05-1
06	REAR SUSPENSION	
	01 – Table of contents.....	06-01-1
	02 – SC-10 Suspension (HP)	06-02-1
	03 – Drive axle.....	06-03-1
	04 – Track.....	06-04-1
07	STEERING/ FRONT SUSPENSION	
	01 – Table of contents.....	07-01-1
	02 – Steering system	07-02-1
	03 – Suspension and ski system.....	07-03-1
08	BODY/FRAME	
	01 – Table of contents.....	08-01-1
	02 – Body	08-02-1
	03 – Frame	08-03-1

TABLE OF CONTENTS

SECTION	SUB-SECTION	PAGE
09	TECHNICAL DATA	
	01 – SI metric information guide.....	09-01-1
	02 – Engines	09-02-1
	03 – Vehicles.....	09-03-1
	04 – Technical data legends.....	09-04-1
<hr/>		
	ANNEXES (wiring diagrams)	

SAFETY NOTICE

This manual has been prepared as a guide to correctly service and repair some 1997 Ski-Doo snowmobiles. See model list on next page.

This edition was primarily published to be used by snowmobile mechanics who are already familiar with all service procedures relating to Bombardier made snowmobiles.

Please note that the instructions will apply only if proper hand tools and special service tools are used.

This *Shop Manual* uses technical terms which may be slightly different from the ones used in *Parts Catalog*.

It is understood that this manual may be translated into another language. In the event of any discrepancy, the English version shall prevail.

The content depicts parts and/or procedures applicable to the particular product at its time of manufacture. It does not include dealer modifications, whether authorized or not by Bombardier, after manufacturing the product.

In addition, the sole purpose of the illustrations throughout the manual, is to assist identification of the general configuration of the parts. They are not to be interpreted as technical drawings or exact replicas of the parts.

The use of Bombardier parts is most strongly recommended when considering replacement of any component. Dealer and/or distributor assistance should be sought in case of doubt.

The engines and the corresponding components identified in this document should not be utilized on product(s) other than those mentioned in this document.

Torque wrench tightening specifications must be strictly adhered to. Locking devices (ex.: locking tab, elastic stop nut, etc.) must be installed or replaced with new ones, when damaged. If the efficiency of a locking device is impaired, it must be renewed.

This manual emphasizes particular information denoted by the wording and symbols;

 WARNING

Identifies an instruction which, if not followed, could cause serious personal injury including possibility of death.

 CAUTION

Denotes an instruction which, if not followed, could severely damage vehicle components.

NOTE: Indicates supplementary information needed to fully complete an instruction.

Although the mere reading of such information does not eliminate the hazard, your understanding of the information will promote its correct use. Always use common shop safety practice.

This information relates to the preparation and use of Bombardier snowmobiles and has been utilized safely and effectively by Bombardier Inc. However, Bombardier Inc. disclaims liability for all damages and/or injuries resulting from the improper use of the contents. We strongly recommend that any services be carried out and/or verified by a highly skilled professional mechanic. It is understood that certain modifications may render use of the vehicle illegal under existing federal, provincial and state regulations.

1997 BOMBARDIER SNOWMOBILES SHOP MANUAL

INTRODUCTION

This *Shop Manual VOLUME 3* covers the following Bombardier made 1997 snowmobiles:

MODELS	MODEL NUMBER
FORMULA* III (CANADA).....	1148
FORMULA* III (U.S.).....	1149
FORMULA* III (EUROPE).....	1150
FORMULA* III LT (CANADA).....	1151
FORMULA* III LT (U.S.).....	1152
FORMULA* III LT (EUROPE).....	1153
MACH* 1 (CANADA).....	1177
MACH* 1 (U.S.).....	1178
MACH* 1 (EUROPE).....	1179
MACH* Z (CANADA).....	1180
MACH* Z (U.S.).....	1181
MACH* Z (EUROPE).....	1182
MACH* Z LT (CANADA).....	1183
MACH* Z LT (U.S.).....	1184
MACH* Z LT (EUROPE).....	1185

*Trademarks of Bombardier Inc.

LIST OF MODELS GROUPED BY COMMON CHASSIS

F-Series consists of:

FORMULA III/III LT
MACH 1/Z/Z LT



TYPICAL — F-SERIES

1997 BOMBARDIER SNOWMOBILES SHOP MANUAL

Each vehicle has its particular vehicle serial number

Serial Number Meaning:

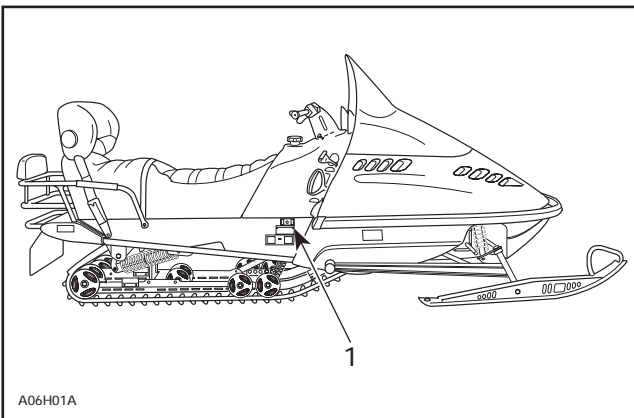
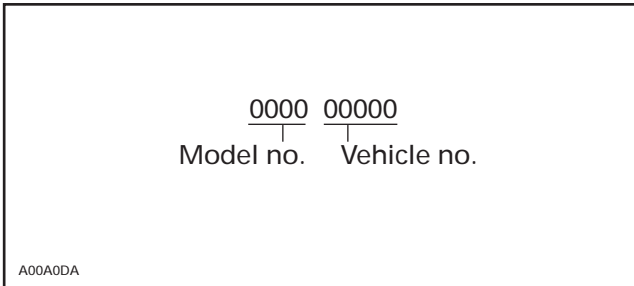

TYPICAL

1. Vehicle serial number

The engine also has a serial number.

Liquid-Cooled Engines

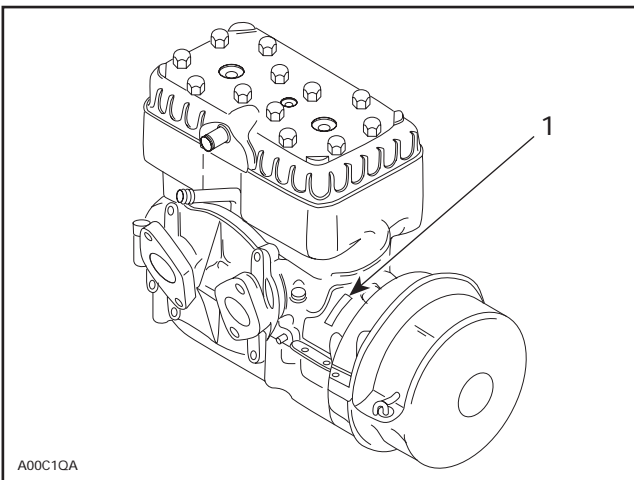

1. Engine serial number

ARRANGEMENT OF THE MANUAL

The manual is divided into 09 major sections:

- 01 LUBRICATION AND MAINTENANCE
- 02 TROUBLESHOOTING
- 03 ENGINE
- 04 TRANSMISSION
- 05 ELECTRICAL
- 06 REAR SUSPENSION
- 07 STEERING/FRONT SUSPENSION
- 08 BODY/FRAME
- 09 TECHNICAL DATA

ANNEXES

Each section is divided in various sub-sections, and again, each sub-section has one or more division.

1997 BOMBARDIER SNOWMOBILES SHOP MANUAL

This *Shop Manual* uses technical terms which may be slightly different from the ones in the parts catalog.

TYPICAL PAGE

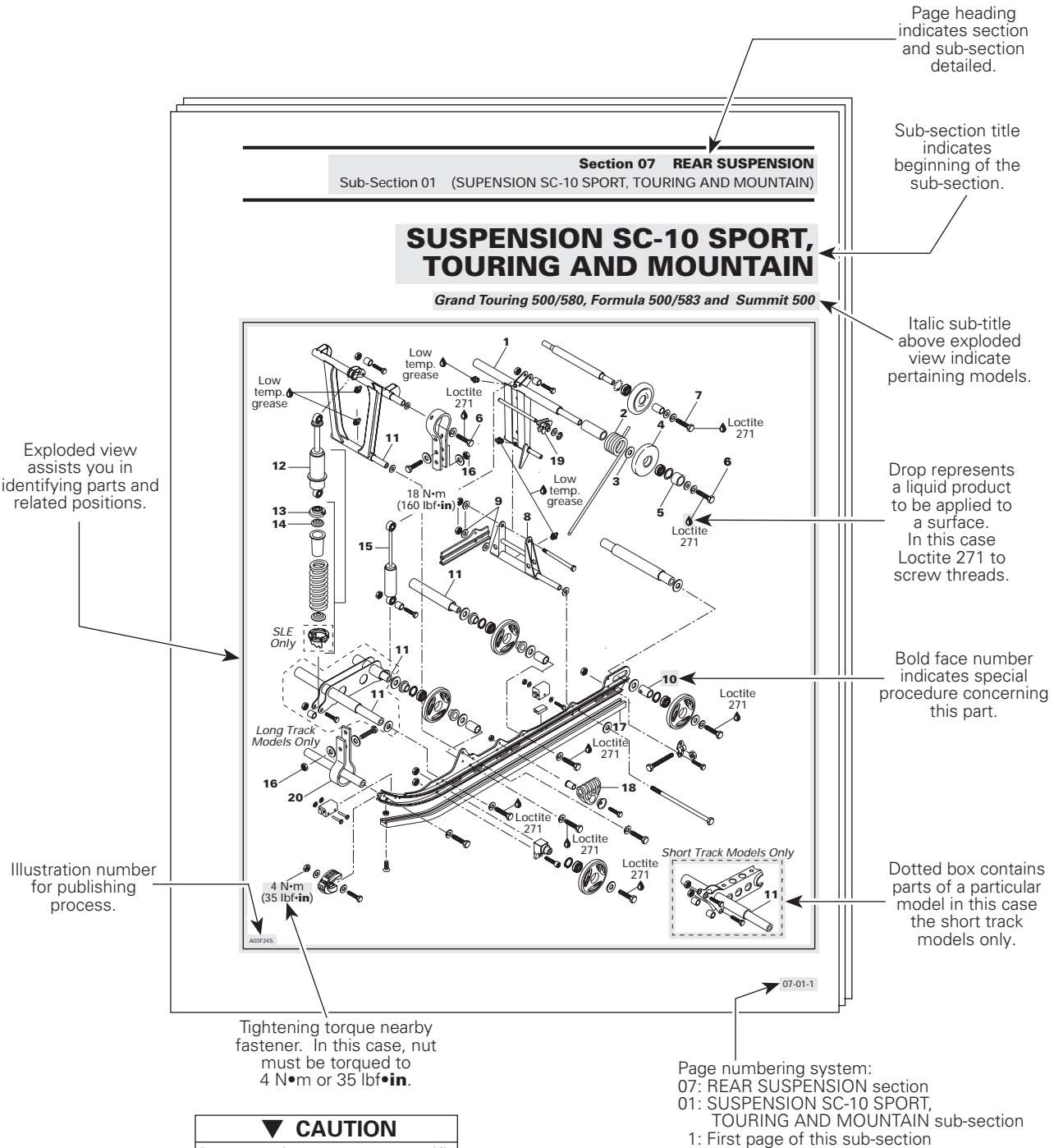

▼ CAUTION
Pay attention to torque specifications. Some of these are in lbf·in instead of lbf·ft. Use appropriate torque wrench.

TYPICAL PAGE

Section 05 TRANSMISSION
Sub-Section 03 (DRIVEN PULLEY)

Turn puller handle and sliding half at once to extract the bushing.

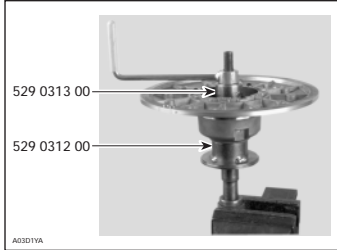

IMPORTANT: Large bushing retaining screws and washers must be removed before small bushing installation.
Coat bushing outside diameter with Loctite 609 (P/N 413 7031 00).
Install bushing as following photo.

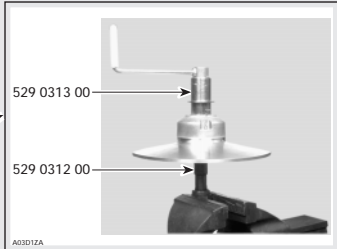

ASSEMBLY
Came Slider Shoe
When replacing slider shoes no. 4, always install a new set (3 shoes) to maintain equal pressure on the cam.
Assemble driven pulley components by reversing the disassembly procedure.

Cam
Coat cam no. 18 interior with anti-seize lubricant.

INSTALLATION
Countershaft

CAUTION
Always apply anti-seize lubricant (P/N 413 7010 00) on the countershaft before final pulley installation.

F-Series and S-Series Only
Should installation procedure be required, refer to BRAKE 05-05 then look for Brake Disc and Countershaft Bearing Adjustment.
Reinstall the pulley on the countershaft by reversing the removal procedure.

All Models
Check end play of driven pulley on countershaft by pushing pulley towards outer housing so that the inner shims (P/N 504 1082 00) contact it. Measure end play at the mounting screw end between shim(s) and pulley. See illustration.

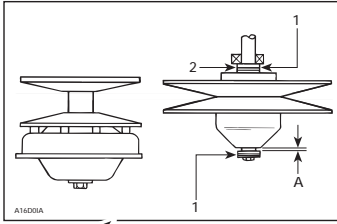

ADJUSTMENT
Refer to PULLEY DISTANCE AND ALIGNMENT 05-04 to adjust pulley distance. Adjust drive belt height between pulley halves to obtain specified belt deflection.

Torque retaining screw no. 13 to 25 N•m (18 lbf•ft).

05-03-5

Number: Following part name refers to exploded view at beginning of sub-section.

Illustration always follows text to which it pertains.

Sub-title indicates a particular procedure for the named part.

Title indicates main procedure to be carried-out.

Italic bold face type setting indicates a particular procedure concerning a model.

Italic bold face setting in this case indicates that particular procedure for F and S-series is finished, so from this point, all models are concerned.

"TYPICAL" caption indicates a general view which does not represent full detail.
"TOP VIEW" caption helps you in understanding illustration.

Call-outs for above illustration.

Reference to look up a certain section and sub-section (PULLEY DISTANCE AND ALIGNMENT 05-04). In this case it concerns pulleys adjustment.

1997 BOMBARDIER SNOWMOBILES SHOP MANUAL

GENERAL INFORMATION

The information and component/system descriptions contained in this manual are correct at time of publication. Bombardier Inc. however, maintains a policy of continuous improvement of its products without imposing upon itself any obligation to install them on products previously manufactured.

Due to late changes, it may have some differences between the manufactured product and the description and/or specifications in this document.

Bombardier Inc. reserves the right at any time to discontinue or change specifications, designs, features, models or equipment without incurring obligation.

USEFUL PUBLICATIONS

Refer to *Parts Catalogs* to order the right parts.

PARTS CATALOG	
MODELS	P/N
FORMULA III/III LT MACH 1/Z/Z LT	480 1432 00

Use *Tools and Accessories Catalog* to order the tools you need.

1994 TOOLS, SERVICE PRODUCTS, OPTION & ACCESSORIES (P/N 480 1343 00).

Use *Specification Booklet* to find rapidly the right specs.

1990-1997 SPECIFICATION BOOKLET (P/N 480 1420 00).

ILLUSTRATIONS AND PROCEDURES

Illustrations and photos show the typical construction of the different assemblies and, in all cases, may not reproduce the full detail or exact shape of the parts shown, however, they represent parts which have the same or a similar function.

▼ CAUTION

Most components of those vehicles are built with parts dimensioned in the metric system. Most fasteners are metric and must not be replaced by customary fasteners or vice versa. Mismatched or incorrect fasteners could cause damage to the vehicle or possible personal injury.

As many of the procedures in this manual are interrelated, we suggest, that before undertaking any task, you read and thoroughly understand the entire section or sub-section in which the procedure is contained.

A number of procedures throughout the book require the use of special tools. Before commencing any procedure, be sure that you have on hand all the tools required, or approved equivalents.

The use of RIGHT and LEFT indications in the text, always refers to driving position (when sitting on vehicle).

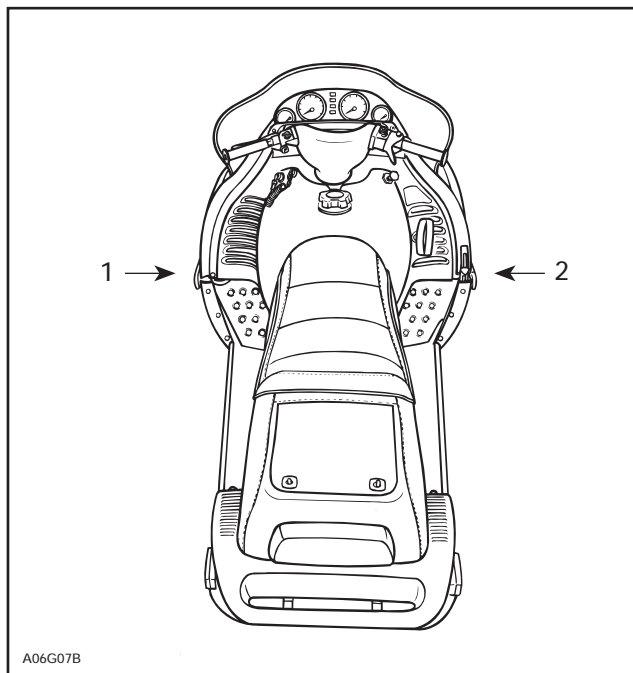

TYPICAL

1. Left
2. Right

1997 BOMBARDIER SNOWMOBILES SHOP MANUAL

TIGHTENING TORQUES

Tighten fasteners to torque mentioned in exploded views and text. When they are not specified refer to following table.

N•m	FASTENER SIZE (8.8)	Lbf•in
1		9
2	M4	18
3	M4	27
4	M5	35
5		44
6		53
7		62
8	M6	71
9	M6	80
10	M6	89
11	M6	97
12	M6	106
13		115
14		124
15		133
16		142
17		150
18		159
19		168

N•m	FASTENER SIZE (8.8)	Lbf•ft
20		15
21	M8	15
22	M8	16
23	M8	17
24	M8	18
25	M8	18
26		19
27		20
28		21
29		21
30		22
31		23
32		24
33		24
34		25
35		26
36		27
37		27
38		28

N•m	FASTENER SIZE (8.8)	Lbf•ft
39		29
40		30
41		30
42		31
43	M10	32
44	M10	32
45	M10	33
46	M10	34
47	M10	35
48	M10	35
49	M10	36
50	M10	37
51	M10	38
52	M10	38
53	M10	39
54		40
55		41
56		41
57		42
58		43
59		44
60		44
61		45
62		46
63		46
64		47
65		48
66		49
67		49
68		50
69		51
70		52
71		52
72		53
73		54
74		55
75		55
76	M12	56
77	M12	57
78	M12	58
79	M12	58
80	M12	59
81	M12	60
82	M12	60
83	M12	61

1997 BOMBARDIER SNOWMOBILES SHOP MANUAL

N•m	FASTENER SIZE (8.8)	Lbf•ft
84	M12	62
85		63
86		63
87		64
88		65
89		66
90		66
91		67
92		68
93		69
94		69
95		70
96		71
97		72
98		72
99		73
100		74
101		74
102		75
103		76
104		77
105		77
106		78
107		79
108		80
109		80
110		81
111		82
112		83
113		83
114		84
115		85
116		86
117		86
118		87
119		88
120		89
121	M14	89
122	M14	90
123	M14	91
124	M14	91
125	M14	92
126	M14	93
127	M14	94
128	M14	94

N•m	FASTENER SIZE (8.8)	Lbf•ft
129	M14	95
130	M14	96
131	M14	97
132	M14	97
133	M14	98
134	M14	99
135	M14	100
136	M14	100
137	M14	101
138	M14	102
139	M14	103
140	M14	103
141	M14	104
142	M14	105
143	M14	105
144	M14	106
145	M14	107
146	M14	108
147	M14	108
148	M14	109
149	M14	110
150	M14	111

TIGHTENING TORQUES FOR 8.8 GRADE BOLTS AND NUTS



Section 01 LUBRICATION AND MAINTENANCE
Sub-Section 01 (LUBRICATION AND MAINTENANCE CHART)

LUBRICATION AND MAINTENANCE CHART

		①	②	③	④	⑤	⑥	REFER TO
	Starting Rope Condition						✓	—
	Engine Head Nuts	✓			✓			Appropriate section: See Top End
	Engine Mount Nuts	✓			✓			Appropriate section: See ENGINE REMOVAL
	Exhaust System	✓		✓				Appropriate section: See ENGINE REMOVAL
	Engine Lubrication						✓	This section no. 1
	Cooling System Condition	✓			✓			Sub-section 03-06
	Coolant Replacement (Except Fan Cooled)						✓	Sub-section 03-06
	Condition of Seals						✓	Sub-section 03-02
	Injection Oil Filter Condition			✓				Sub-section 03-05
	Injection Oil Filter Replacement						✓	Sub-section 03-05
	Oil Injection Pump Adjustment	✓			✓			Sub-section 03-05
	Fuel Stabilizer					✓		This section no. 2
	Fuel Filter Replacement						✓	This section no. 3
	Fuel Lines and Connections	✓					✓	Sub-section 03-09
	Carburetor Adjustment	✓			✓			Sub-section 03-08
	Throttle Cable Inspection	✓			✓		✓	Sub-section 03-09
	Air Filter Cleaning			✓				This section no. 4
	Drive Belt Condition	✓	✓					This section no. 5
	Condition of Drive and Driven Pulleys	✓		✓		✓		Sub-sections 04-03 and 04-04
	Cleaning of Drive and Driven Pulleys						✓	Sub-sections 04-03 and 04-04
	Retorquing of Drive Pulley Screw	✓						Sub-section 04-03
	Driven Pulley Preload	✓			✓			Sub-section 04-04
	Brake Condition	✓	✓					Sub-section 04-06
	Brake Adjustment			✓				Sub-section 04-06
	Lubrication of Ratchet Wheel or Fluid Change						✓	Sub-section 04-06
	Drive Chain Tension	✓		✓				Sub-section 04-07
	Countershaft Lubrication (S and F Series)	✓		✓		✓		Sub-section 04-06
	Chaincase/Gearbox Oil Level	✓		✓		✓		Sub-section 04-07
	Chaincase/Gearbox Oil Change	✓ ¹				✓		Sub-section 04-07
	Lubrication of drive axle bearing	✓		✓		✓		Sub-section 06-04
	Handlebar Bolts. Retorque to 26 N•m (19 lbf•ft)	✓						Sub-section 07-02
	Steering and Front Suspension Mechanism	✓		✓		✓		Sub-sections 07-02 and 07-03
	Wear and Condition of Skis and Runners	✓	✓					Sub-section 07-03
	Steering and Ski Leg Camber Adjustment	✓		✓				Sub-section 07-02

Section 01 LUBRICATION AND MAINTENANCE

Sub-Section 01 (LUBRICATION AND MAINTENANCE CHART)

		①	②	③	④	⑤	⑥	REFER TO
	Suspension Adjustments	AS REQUIRED						Section 06: See appropriate sub-section and <i>Operator's Guide</i>
	Suspension Lubrication			✓2		✓		Section 06: See appropriate sub-section
	Suspension Condition	✓			✓			Section 06: See appropriate sub-section
	Suspension Stopper Strap Condition				✓			Section 06: See appropriate sub-section
	Track Condition	✓		✓				Sub-section 06-04
	Track Tension and Alignment	✓	AS REQUIRED					
	Spark Plugs*	✓						Sub-section 05-04
	Engine Timing	✓					✓	Sub-section 05-03
	Battery Condition	✓		✓		✓		Not applicable
	Headlight Beam Aiming				✓			Sub-section 08-02
	Wiring Harnesses, Cables and Lines	✓		✓				Sub-section 08-02
	Operation of Lighting System (HI/LO Beam, Brake Light, etc.) Test Operation of Emergency Cut-Out Switch and Tether Cut-Out Switch	✓	✓				✓	<i>Operator's Guide</i>
	Rags in Air Intake and Exhaust System					✓	✓	This section no. 6
	Engine Compartment	✓		✓				This section no. 7
	General Inspection	✓		✓		✓		This section no. 8

* Before installing new spark plugs at pre-season preparation, it is suggested to burn excess storage oil by starting the engine with the old spark plugs. Only perform this operation in a well ventilated area.

① 10-HOUR OR 500 km (300 mi) INSPECTION (To be performed by dealer)

② WEEKLY OR EVERY 240 km (150 mi)

③ MONTHLY OR EVERY 800 km (500 mi)

④ ONCE A YEAR OR EVERY 3200 km (2000 mi)

⑤ STORAGE (To be performed by dealer)

⑥ PRE-SEASON PREPARATION (To be performed by dealer)

1. Change oil at 10-hour inspection for Skandic WT/SWT/WT LC

2. Apply anti-seize lubricant (P/N 413 7010 00) on ACM rod every 10 hours or 500 km (300 mi).

Section 01 LUBRICATION AND MAINTENANCE
Sub-Section 01 (LUBRICATION AND MAINTENANCE CHART)

NO. 1 ENGINE LUBRICATION

Engine internal parts must be lubricated to protect them from possible rust formation during the storage period.

To perform the storage procedures, proceed as follows:

Start the engine and allow it to run at idle speed until the engine reaches its operating temperature.

◆ WARNING

Ensure the track is free of all particles which could be thrown out while it is rotating. Keep hands, tools, feet and clothing clear of track. Ensure no one is standing in close proximity to the vehicle.

Stop the engine.

Remove air silencers to spray storage oil into each carburetor bore.

Restart engine and run at idle speed.

Inject storage oil until the engine stalls or until a sufficient quantity of oil has entered the engine (approximately half a can).

With the engine stopped, remove the spark plug and spray storage oil (P/N 496 0141 00) into each cylinder.

Crank slowly 2 or 3 revolutions to lubricate cylinders.

Reinstall the spark plugs and the outlet primer hose or air silencers.

◆ WARNING

This procedure must only be performed in a well ventilated area. Do not run engine during storage period.

NO. 2 FUEL STABILIZER

A fuel stabilizer (P/N 413 4086 00) can be added in fuel tank to prevent fuel deterioration and avoid draining fuel system for storage. Follow manufacturer's instructions for proper use.

If above fuel stabilizer is not used, drain fuel system including fuel tank and carburetor(s).

▼ CAUTION

Fuel stabilizer should be added prior engine lubrication to ensure carburetor(s) protection against varnish deposit.

NO. 3 FUEL FILTER REPLACEMENT

Drain fuel tank.

Remove fuel line grommet from fuel tank and pull out inlet fuel line from tank.

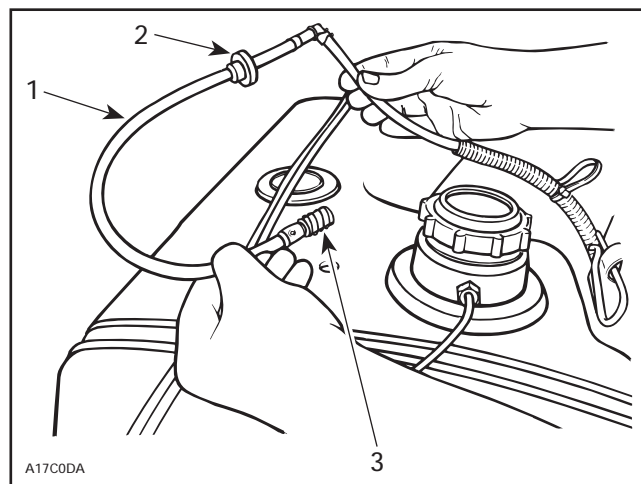

TYPICAL

1. Inlet fuel line
2. Position of grommet when installing
3. Fuel filter

Replace fuel filter. To facilitate the fuel line installation, slide grommet on fuel line about 50 mm (2 in) away from elbow then install grommet on fuel tank and push elbow through grommet.

NO. 4 AIR FILTER CLEANING

Check that the air box is clean and dry then properly reinstall the filter.

▼ CAUTION

These snowmobiles have been calibrated with the filter installed. Operating the snowmobile without it may cause engine damage.

Section 01 LUBRICATION AND MAINTENANCE

Sub-Section 01 (LUBRICATION AND MAINTENANCE CHART)

Lift hood and remove air filters from air intake silencer.

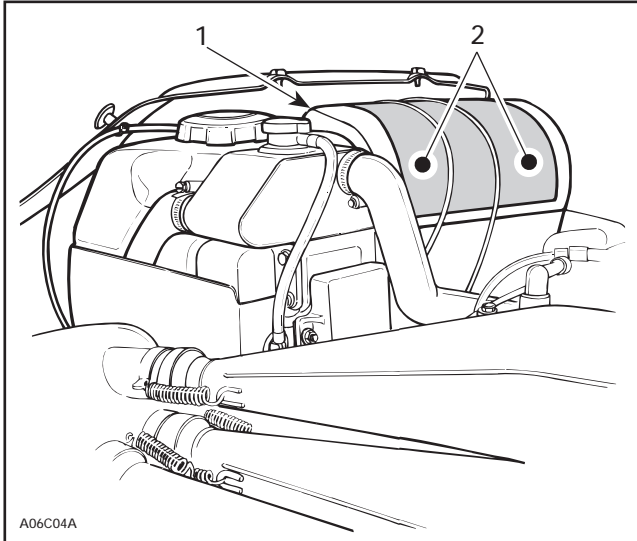

TYPICAL

1. Air intake silencer
2. Air filters

To clean a filter, shake the snow out of it then, dry it out.

NO. 5 DRIVE BELT CONDITION

Inspect belt for cracks, fraying or abnormal wear (uneven wear, wear on one side, missing cogs, cracked fabric). If abnormal wear is noted, probable cause could be pulley misalignment, excessive RPM with frozen track, fast starts without warm-up period, burred or rusty sheave, oil on belt or distorted spare belt.

Check the drive belt width. Replace the drive belt if width is less than the minimum width recommended in DRIVE BELT 04-02.

NO. 6 RAGS IN AIR INTAKE AND EXHAUST SYSTEM

At storage preparation, block air intake hole and exhaust system hole using clean rags.

Remove those rags at pre-season preparation.

NO. 7 ENGINE COMPARTMENT

Keep clean of grass, twigs, cloth, etc. These are combustible under certain conditions.

NO. 8 GENERAL INSPECTION

Remove any dirt or rust.

To clean the entire vehicle, use only flannel clothes or Kimtowels® wipers no. 58-380 from Kimberly-Clark.

▼ CAUTION

It is necessary to use flannel cloths or "Kimtowels" wipers on windshield and hood to avoid damaging further surfaces to clean.

To clean the entire vehicle, including metallic parts with a **thick** coat of grease, use "Endust" imported by Bristol Myers, available at hardware stores or supermarkets.

To clean the entire vehicle, including metallic parts with a **thin** coat of grease, use "Simple Green" from Sunshine Makers Inc., available at hardware stores or at automotive parts retailer.

To remove scratches on windshield or hood: Start with "Slip Streamer Motorcycle Windshield Heavy Duty Scratch, Remover". Finish with "Slip Streamer Motorcycle Cleaner and Polish".

NOTE: The latest product may be use alone if only light scratches are noticeable.

▼ CAUTION

Never clean plastic parts or hood with strong detergent, degreasing agent, paint thinner, acetone, products containing chlorine, etc.

Inspect the hood and repair any damage. Touch up all metal spots where paint has been scratched off. Spray all metal parts including shock chromed rods with Bombardier Lube (P/N 293 6000 06). Wax the hood and the painted portion of the frame for better protection.

NOTE: Apply wax on glossy finish only. Protect the vehicle with a cover to prevent dust accumulation during storage.

▼ CAUTION

The snowmobile has to be stored in a cool and dry place and covered with an opaque tarpaulin This will prevent sun rays and grime from affecting plastic components and vehicle finish.

TABLE OF CONTENTS

ENGINE	02-02-1
<hr/>	
FUEL AND OIL SYSTEMS	02-03-1
<hr/>	
TRANSMISSION AND BRAKE SYSTEMS	02-04-1
TRANSMISSION	02-04-1
BRAKE SYSTEM	02-04-8
MECHANICAL BRAKE	02-04-8
HYDRAULIC BRAKE	02-04-9
MECHANICAL AND HYDRAULIC BRAKES	02-04-9
<hr/>	
ELECTRICAL SYSTEM.....	02-05-1
<hr/>	
SUSPENSION SYSTEM AND TRACK	02-06-1

ENGINE

The following chart is provided to help in diagnosing the probable source of troubles. It should be used as a guideline. Some causes or corrections may not apply to a specific model.

SYMPTOM	ENGINE BACKFIRES
CONDITION	NORMAL USE
Test/Inspection	1. Check spark plug(s). a. Carbon accumulation caused by defective spark plug(s). <i>Clean carbon accumulation and replace spark plug(s).</i>
	2. Check cooling system. a. Loose fan belt. <i>Adjust or replace fan belt (refer to TECHNICAL DATA 09).</i> b. Low antifreeze level. <i>Adjust antifreeze level. Then check clamps or hoses.</i> c. Defective tank cap or thermostat. <i>Replace.</i> d. Air in system. <i>Bleed system.</i>
	3. Check ignition timing. a. Timing is too advanced. <i>Set timing according to specifications (refer to TECHNICAL DATA 09).</i>

Section 02 TROUBLESHOOTING

Sub-Section 02 (ENGINE)

SYMPTOM	ENGINE SUDDENLY TURNS OFF
CONDITION	NORMAL USE
Test/Inspection	1. Perform engine leak test. Refer to engine leak verification flow chart. Check possible piston seizure. a. Damaged gasket and/or seal. <i>Replace defective parts.</i>
	2. "Four-corner" seizure of piston(s). a. Accelerating too fast when engine is cold. Piston expands faster than cylinder. <i>Replace piston(s). Ask driver to refer to warm-up procedure in Operator's Guide.</i>
	3. Piston(s) seizure on exhaust side (color on piston dome is correct). a. Kinked fuel tank vent tube. <i>Relocate fuel tank vent tube.</i> b. Leaks at fuel line connections or damaged fuel lines. <i>Replace defective lines.</i> c. Fuel does not flow through carburetor(s) (plastic particles in needle area and/or varnish formation in carburetor(s)). <i>Clean carburetor(s).</i> d. Spark plug heat range is too warm. <i>Install spark plug(s) with appropriate heat range (refer to TECHNICAL DATA 09).</i> e. Improper ignition timing. <i>Adjust according to specifications (refer to TECHNICAL DATA 09).</i> f. Restriction in exhaust system. <i>Replace.</i> g. Compression ratio is too high. <i>Install genuine parts.</i> h. Carburetor calibration is too lean. <i>Adjust according to specifications (refer to TECHNICAL DATA 09).</i> i. Improper rotary valve timing or improper valve. <i>Adjust according to specifications (refer to TECHNICAL DATA 09) and/or install Bombardier's recommended rotary valve.</i> j. Poor quality oil. <i>Use Bombardier Rotax oil.</i> k. Leaks at air intake silencer. <i>Replace air intake silencer grommets.</i>

	<p>4. Melted and/or perforated piston dome; melted section at ring end gap.</p> <p>a. When piston reaches TDC, mixture is ignited by heated areas in combustion chamber. This situation is due to an incomplete combustion of a poor quality oil. <i>Clean residue accumulation in combustion chamber and replace piston(s). Use Bombardier Rotax oil.</i></p> <p>b. Spark plug heat range is too high. <i>Install recommended spark plug(s) (refer to TECHNICAL DATA 09).</i></p> <p>c. Ignition timing is too advanced. <i>Adjust according to specifications (refer to TECHNICAL DATA 09).</i></p> <p>d. Inadequate fuel quality. <i>Use appropriate fuel.</i></p> <p>e. Carburetion is too lean. <i>Adjust according to specifications (refer to TECHNICAL DATA 09).</i></p> <p>5. Seized piston all around the circumference (dry surface).</p> <p>a. Lack of oil, damaged oil line or defective injection pump. <i>Replace defective part(s).</i></p> <p>6. Grooves on intake side of piston only.</p> <p>a. Oil film eliminated by water (snow infiltration in engine). <i>Replace piston(s) and check if intake system leaks.</i></p> <p>7. Piston color is dark due to seizure on intake and exhaust sides.</p> <p>a. Broken or loose fan belt. <i>Replace fan belt or adjust its tension (refer to TECHNICAL DATA 09).</i></p> <p>b. Cooling system leaks and lowers coolant level. <i>Tighten clamps or replace defective parts. Add antifreeze in cooling system until appropriate level is reached.</i></p> <p>c. Accumulation of foreign particles in needle and/or main jet area. <i>Clean carburetor(s).</i></p> <p>8. Cracked or broken piston(s).</p> <p>a. Cracked or broken piston(s) due to excessive piston/cylinder clearance or engine overrevving. <i>Replace piston(s). Check piston/cylinder clearance (refer to TECHNICAL DATA 09). Adjust drive pulley according to specifications (refer to TECHNICAL DATA 09) and/or clean pulley sheaves if they are contaminated with greasy particles.</i></p>
--	---------------------------------------------------------------------------------------------------------------------------------------------------------------------------------------------------------------------------------------------------------------------------------------------------------------------------------------------------------------------------------------------------------------------------------------------------------------------------------------------------------------------------------------------------------------------------------------------------------------------------------------------------------------------------------------------------------------------------------------------------------------------------------------------------------------------------------------------------------------------------------------------------------------------------------------------------------------------------------------------------------------------------------------------------------------------------------------------------------------------------------------------------------------------------------------------------------------------------------------------------------------------------------------------------------------------------------------------------------------------------------------------------------------------------------------------------------------------------------------------------------------------------------------------------------------------------------------------------------------------------------------------------------------------------------------------------------------------------------------------------------------------------------------------------------------------------------------------------------------------------------------------------------------------------------------------------------------------------------------------------------------------------------------------------------------------------------------------------------------------

Section 02 TROUBLESHOOTING

Sub-Section 02 (ENGINE)

SYMPTOM	PISTON RING AND CYLINDER SURFACES ARE GROOVED
CONDITION	NORMAL USE
Test/Inspection	1. Check oil quality. a. Poor oil quality. <i>Use Bombardier Rotax oil.</i>
	2. Check injection pump and its hoses. a. Inadequate injection pump adjustment and/or defective hoses. <i>Adjust pump according to specifications (refer to ENGINE 03) and/or replace hoses.</i>

SYMPTOM	ENGINE DOES NOT OFFER MAXIMUM POWER AND/OR DOES NOT REACH MAXIMUM OPERATING RPM
CONDITION	NORMAL USE
Test/Inspection	1. Check spark plug condition. a. Fouled spark plug(s). <i>Replace.</i>
	2. Check if there is water in fuel. a. There is water in fuel. <i>Drain fuel system, then fill it with appropriate fuel.</i>
	3. Check items listed in "Engine runs out of fuel" (refer to fuel and oil system sub-section 02).
	4. Check carburetor adjustments and cleanliness. a. Inadequate carburetor adjustments or dirt accumulation. <i>Adjust according to specifications (refer to TECHNICAL DATA 09) or clean.</i>
	5. Check drive belt. a. Worn belt. <i>Replace belt if width is 3 mm (1/8") less than nominal dimension (refer to TECHNICAL DATA 09).</i>
	6. Check track adjustment. a. Too much tension and/or improper alignment. <i>Align track and adjust its tension to specifications (refer to TECHNICAL DATA 09).</i>
	7. Check drive pulley. a. Improper calibration screw adjustments (TRA pulley) and/or worn bushing(s). <i>Adjust according to specifications (refer to TECHNICAL DATA 09) and/or replace bushing(s).</i>

Section 02 TROUBLESHOOTING
Sub-Section 02 (ENGINE)

	<p>8. Check driven pulley. a. Worn bushing and/or spring tension. <i>Replace spring and/or adjust its tension according to specifications (refer to TECHNICAL DATA 09).</i></p>
	<p>9. Check exhaust system. a. Restriction. <i>Replace.</i></p>
	<p>10. Check ignition timing. a. Decrease in power due to retarded ignition. <i>Adjust according to specification (refer to TECHNICAL DATA 09).</i></p>
	<p>11. Check engine compression. a. Worn piston(s) and ring(s). <i>Replace (refer to TECHNICAL DATA 09 for specification).</i></p>
	<p>12. Check engine cooling system. a. Engine overheats. Improper fan belt tension. <i>Adjust fan belt (refer to TECHNICAL DATA 09).</i> b. Antifreeze level is low, cap fails to pressurize system or air circulates through lines. <i>Adjust level, replace cap or bleed cooling system.</i></p>

SYMPTOM	ENGINE DETONATION AT MAXIMUM RPM
CONDITION	NORMAL USE
Test/Inspection	<p>1. Check which type of fuel is used. a. Octane number is too low and/or alcohol level is too high. <i>Use recommended fuel type.</i></p>
	<p>2. Check spark plug type. a. Improper spark plug heat range. <i>Install recommended spark plug(s) (refer to TECHNICAL DATA 09).</i></p>
	<p>3. Check exhaust system. a. Too much restriction. <i>Replace.</i></p>
	<p>4. Check ignition timing. a. Timing is too advanced. <i>Adjust according to specification (refer to TECHNICAL DATA 09).</i></p>
	<p>5. Check carburetion. a. Fouled and/or improper carburetor components. <i>Clean or replace according to specification (refer to TECHNICAL DATA 09).</i></p>
	<p>6. Check compression ratio and squish area. a. Compression ratio is too high. <i>Install genuine parts.</i></p>

Section 02 TROUBLESHOOTING

Sub-Section 02 (ENGINE)

SYMPTOM	ENGINE TURNS OVER BUT FAILS TO START
CONDITION	NORMAL USE
Test/Inspection	1. Check switches. a. Ignition switch, emergency cut-out switch or tether switch is in the OFF position. <i>Place all switches in the RUN or ON position.</i>
	2. Check fuel level. a. Mixture not rich enough to start cold engine. <i>Check fuel tank level and use primer.</i>
	3. Check spark plug. a. Defective spark plug (no spark). <i>Replace spark plug(s).</i>
	4. Check amount of fuel on spark plug. a. Flooded engine (spark plug wet when removed). <i>Do not overprime. Remove wet spark plug(s), turn ignition switch to OFF and crank engine several times. Install clean dry spark plug. Start engine following usual starting procedure.</i>
	5. Check fuel lines. a. No fuel to the engine (spark plug dry when removed). <i>Check fuel tank level; turn fuel valve on if applicable; check fuel filter, replace if clogged; check condition of fuel and impulse lines and their connections.</i>
	6. Check engine compression. a. Insufficient engine compression. <i>Replace defective part(s) (ex.: piston(s), ring(s), etc.).</i>

SYMPTOM	IRREGULAR ENGINE IDLE
CONDITION	NORMAL USE AFTER ENGINE WARM UP
Test/Inspection	1. Check primer. a. Fuel leaks at primer nipple which is mounted to carburetor. <i>Replace.</i>
	2. Check choke. a. Choke plunger may be partially opened. <i>Readjust.</i>
	3. Check carburetor adapter. a. Air enters through a crack. <i>Replace.</i>
	4. Check air screw position. a. Inadequate fuel/air mixture. <i>Adjust according to specifications (refer to TECHNICAL DATA 09).</i>

Section 02 TROUBLESHOOTING
Sub-Section 02 (ENGINE)

	<p>5. Check ignition system trigger coil air gap.</p> <p>a. Air gap is too large. <i>Adjust according to specifications (refer to TECHNICAL DATA 09).</i></p>
	<p>6. Check dimension of pilot jet.</p> <p>a. Inadequate fuel/air mixture. <i>Adjust according to specifications (refer to TECHNICAL DATA 09).</i></p>
	<p>7. Perform engine leak test. (Refer to LEAK TEST AND ENGINE DIMENSION MEASUREMENT 03-03).</p> <p>a. Leaking gaskets allow air to enter in engine. <i>Replace defective parts.</i></p>

SYMPTOM	HIGH ENGINE OPERATING TEMPERATURE
CONDITION	NORMAL USE
Test/Inspection	<p>1. Check temperature gauge sensor.</p> <p>a. False reading. <i>Replace.</i></p>
	<p>2. Check fan belt.</p> <p>a. Belt slides because it is too loose. <i>Adjust according to specifications (refer to TECHNICAL DATA 09).</i></p>
	<p>3. Verify antifreeze level and check if there is air infiltration in the system or if there are leaks in gasket areas.</p> <p>a. Low antifreeze level or air in system.</p> <p>b. <i>Add antifreeze until recommended level is reached, bleed system and/or tighten clamps at fitting.</i></p>
	<p>4. Check if antifreeze flows through system properly.</p> <p>a. Foreign particles and/or broken coolant pump impeller. <i>Clean cooling system and/or replace coolant pump impeller.</i></p>
	<p>5. Check thermostat.</p> <p>a. Thermostat reacts slowly or not at all. <i>Replace.</i></p>
	<p>6. Check antifreeze concentration.</p> <p>a. Antifreeze concentration is too high. <i>Adjust concentration according to Bombardier's recommendations.</i></p>
	<p>7. Check tank cap.</p> <p>a. Cap does not hold pressure. <i>Replace.</i></p>

Section 02 TROUBLESHOOTING

Sub-Section 02 (ENGINE)

	<p>8. Check carburetion.</p> <p>a. Improperly adjusted or inadequate carburetor components. <i>Adjust according to specifications (refer to TECHNICAL DATA 09) or replace inadequate component(s).</i></p>
	<p>9. Check cylinder head gaskets.</p> <p>a. Worn gaskets. <i>Replace.</i></p>
	<p>10. Check ignition timing.</p> <p>a. Ignition timing is too advanced. <i>Adjust according to specifications (refer to TECHNICAL DATA 09).</i></p>
	<p>11. Check if there are leaks at air intake silencer and/or engine crankcase.</p> <p>a. Leak(s). <i>Repair or replace.</i></p>
	<p>12. Check condition and heat range of spark plug(s).</p> <p>a. Melted spark plug tip or inadequate heat range. <i>Replace.</i></p>

SYMPTOM	ENGINE EQUIPPED WITH "RAVE" VALVE DOES NOT REACH ITS FULL OPERATING RPM (500 TO 1000 RPM SLOWER)
CONDITION	NORMAL USE
Test/Inspection	<p>1. Check "RAVE" valve pistons.</p> <p>a. Valve piston(s) is (are) too far out. <i>Screw valve piston(s) to bottom.</i></p>
	<p>2. Check "RAVE" valve stems.</p> <p>a. Bent "RAVE" valve stem(s). <i>Replace.</i></p>
	<p>3. Check "RAVE" valves.</p> <p>a. Jammed valve(s). <i>Clean.</i></p>
	<p>4. Check tension of "RAVE" springs.</p> <p>a. Inadequate spring tension. <i>Replace.</i></p>
	<p>5. Check "RAVE" pressure holes.</p> <p>a. Clogged holes. <i>Clean.</i></p>
	<p>6. Check clamps or sleeves.</p> <p>a. Damaged clamp(s) or sleeve(s). <i>Replace.</i></p>

Section 02 TROUBLESHOOTING
Sub-Section 02 (ENGINE)

SYMPTOM	ENGINE EQUIPPED WITH "RAVE". ENGINE HESITATES AT MID-SPEED AND REACHES MAXIMUM PERFORMANCE ONLY AFTER A WHILE
CONDITION	NORMAL USE
Test/Inspection	1. Check "RAVE" valve spring(s). a.Spring tension is too weak or spring(s) is (are) broken. <i>Replace.</i>
	2. Check "RAVE" valve cover red adjustment screws. a.Adjustment screw(s) is (are) too loose. <i>Fully tighten.</i>
	3. Check "RAVE" valve movement ("RAVE" movement indicator P/N 861 7258 00). a.Valve(s) is (are) stuck in open position. <i>Clean.</i>

SYMPTOM	REWIND STARTER ROPE DOES NOT REWIND
CONDITION	NORMAL USE
Test/Inspection	1. Check rewind spring. a.Broken spring. <i>Replace spring.</i>

SYMPTOM	REWIND STARTER PAWL DOES NOT ENGAGE
CONDITION	NORMAL USE
Test/Inspection	1. Check stopper spring. a.Broken stopper spring. <i>Replace.</i>
	2. Check pawl and pawl lock. a.Pawl and pawl lock have stuck together because of heat. <i>Replace and use recommended greases.</i>
	3. Check pawl and rope sheave. a.Pawl and rope sheave have stuck together because of heat. <i>Replace.</i>

Section 02 TROUBLESHOOTING

Sub-Section 02 (ENGINE)

SYMPTOM	ENGINE PINGING
CONDITION	NORMAL USE
Test/Inspection	1. Check fuel lines. a. Bent fuel lines (preventing fuel from flowing through). <i>Relocate or replace fuel lines.</i>
	2. Check if carburetor(s) is (are) clean. a. Dirt prevents fuel from flowing through. <i>Clean.</i>
	3. Check ignition timing. a. Timing is too advanced. <i>Adjust according to specifications (refer to TECHNICAL DATA 09).</i>
	4. Check compression ratio. a. Compression ratio is too high. <i>Replace inadequate part(s) to obtain manufacturer's recommended compression ratio or use a higher grade fuel.</i>

SYMPTOM	ENGINE GENERATES A LOT OF VIBRATIONS
CONDITION	NORMAL USE
Test/Inspection	1. Check engine supports. a. Loose broken supports or interference between support(s) and chassis. <i>Retighten to specification (refer to TECHNICAL DATA 09) or replace.</i>
	2. Check drive pulley (refer to: vibrations coming from drive pulley).
	3. Check carburetor synchronization. a. Throttle slide heights are adjusted differently and/or throttle slide openings are unsynchronized. <i>Adjust throttle slide heights and throttle cable.</i>

FUEL AND OIL SYSTEMS

The following chart is provided to help in diagnosing the probable source of troubles. It should be used as a guideline. Some causes or corrections may not apply to a specific model.

SYMPTOM	HIGH FUEL CONSUMPTION (OR RICH MIXTURE)
CONDITION	NORMAL USE
Test/Inspection	1. Check fuel tank. a.Perforated fuel tank. <i>Replace fuel tank.</i>
	2. Check fuel pump reservoir and carburetor fittings. a.Leaking fittings. <i>Replace defective part.</i>
	3. Check primer. a.Fuel flows through primer while engine runs. <i>Replace primer.</i>
	4. Check float height in carburetor(s). a.Fuel level is too high in float bowl(s). <i>Adjust according to specifications (refer to TECHNICAL DATA 09).</i>
	5. Check needle valve. a.Foreign particles prevent needle valve(s) from closing and/or worn seating area. <i>Clean or replace needle valve(s), then clean seating area.</i>
	6. Check H.A.C. system. a.Connection to atmosphere is plugged. <i>Clean.</i> b.Leakage in H.A.C. to carburetor tube. <i>Replace.</i> c.Leak in H.A.C. sealed chamber. <i>Replace.</i> d.H.A.C. frozen. <i>Replace.</i>
SYMPTOM	FUEL LEAKS IN ENGINE BASE WHEN ENGINE IS STOPPED
CONDITION	NORMAL USE
Test/Inspection	1. Check items 3, 4 and 5 of "High fuel consumption".
	2. Check fuel pump diaphragm. a.Cracked diaphragm. <i>Replace.</i>

Section 02 TROUBLESHOOTING

Sub-Section 03 (FUEL AND OIL SYSTEMS)

SYMPTOM	ENGINE LACKS POWER OR STALLS AT HIGH RPM
CONDITION	NORMAL USE
Test/Inspection	1. Check fuel tank vent hose. a.Kinked or clogged hose. <i>Relocate or replace.</i>
	2. Check fuel filter. a.Clogged filter. <i>Replace.</i>
	3. Check fuel lines. a.Kinked or clogged lines. <i>Relocate or replace.</i>
	4. Check fuel pump flow. a.Dried diaphragm. <i>Replace.</i>
	5. Check if carburetor(s) is (are) clean. a.Varnish. <i>Clean.</i>

SYMPTOM	HIGH INJECTION OIL CONSUMPTION
CONDITION	NORMAL USE
Test/Inspection	1. Check oil injection pump adjustment. a.Oil injection pump adjusted too rich. <i>Adjust.</i>
	2. Check injection oil lines and their fitting. a.Leaking lines and/or cover. <i>Replace defective part(s).</i>
	3. Check injection pump cover gasket. a.Worn gasket. <i>Replace.</i>
	4. Pressurize crankcase rotary valve gear reservoir. a.Leaking gasket(s). <i>Replace gasket(s).</i>

Section 02 TROUBLESHOOTING
Sub-Section 03 (FUEL AND OIL SYSTEMS)

SYMPTOM	ENGINE RUNS OUT OF FUEL (OR LEAN MIXTURE)
CONDITION	NORMAL USE
Test/Inspection	<p>1. Check fuel filter ball located in fuel tank. Ball must move freely.</p> <p>a. Corrosion due to oxidation at installation. <i>Replace fuel filter.</i></p>
	<p>2. Check if lines are perforated or kinked and make sure they do not leak at fittings.</p> <p>a. Lines are too big for their fittings or are improperly routed. <i>Replace or properly relocate lines.</i></p>
	<p>3. Check fuel pump outlet flow.</p> <p>a. Dirt clogging fuel pump lines or torn membrane. <i>Clean or replace fuel pump.</i></p>
	<p>4. Check carburetor needle valve(s).</p> <p>a. Dirt (varnish, foreign particle) clogging fuel b. Inlet inlets. <i>Clean.</i></p>
	<p>5. Check main jet.</p> <p>a. Dirt (varnish, foreign particle) accumulation at main jet. <i>Clean.</i></p>
	<p>6. Check float height in carburetor bowl(s).</p> <p>a. Running out of fuel at high speed because float height is too low. <i>Adjust float lever height according to specification.</i></p>
	<p>7. Check H.A.C. system.</p> <p>a. Plugged hole in air jet inlet. <i>Clean.</i></p> <p>b. H.A.C. frozen. <i>Replace.</i></p>

TRANSMISSION AND BRAKE SYSTEMS

The following charts are provided to help in diagnosing the probable source of troubles. It should be used as a guideline. Some causes or corrections may not apply to a specific model.

TRANSMISSION

SYMPTOM	THE SNOWMOBILE ACCELERATES SLOWLY, ESPECIALLY WHEN IT IS STOPPED
CONDITION	NORMAL USE
Test/Inspection	1. Check drive belt condition. a. Belt is too narrow (drive belt engagement is higher in drive pulley). <i>Replace belt if width is 3 mm (1/8") less than a new one (refer to TECHNICAL DATA 09).</i>
	2. Check distance between pulleys and/or drive belt deflection. a. Distance is too small between pulleys or deflection is too high (drive belt engagement is higher in drive pulley). <i>Adjust distance between pulleys and/or drive belt deflection according to specifications (refer to TECHNICAL DATA 09).</i>
	3. Check driven pulley sliding half play. a. Jammed sliding half. <i>Replace.</i>
	4. Check spring tension of driven pulley sliding half. a. Sliding half rotation is accelerated when spring tension is too weak. <i>Adjust according to specifications (refer to TECHNICAL DATA 09).</i>
	5. Refer to "Vibrations originating from driven pulley" and check items listed.
	6. Check drive pulley spring tension. a. Spring tension is too weak. <i>Replace.</i>

Section 02 TROUBLESHOOTING

Sub-Section 04 (TRANSMISSION AND BRAKE SYSTEMS)

SYMPTOM	ENGINE MAXIMUM RPM IS TOO HIGH AND TOP SPEED IS NOT REACHED
CONDITION	NORMAL USE
Test/Inspection	1. Check items 1, 2 and 3 of “The snowmobile accelerates slowly, especially when it is stopped”.
	2. Check driven pulley spring tension. a.Spring tension is too stiff. <i>Adjust according to specification (refer to TECHNICAL DATA 09).</i>
	3. Check position of the calibration screws. (TRA drive pulley). a.Selected numbers are too high. <i>Adjust according to specification (refer to TECHNICAL DATA 09).</i>
	4. Refer to “Vibrations originating from driven pulley” and check items listed.

SYMPTOM	LOOSENESS IS FELT IN DRIVE SYSTEM WHEN ACCELERATING/DECELERATING
CONDITION	NORMAL USE
Test/Inspection	1. Check drive chain tension. a.Drive chain is too loose. <i>Adjust.</i>
	2. Check play of driven pulley key (aluminum frame models). a.Worn key or keyway. <i>Replace.</i>

Section 02 TROUBLESHOOTING
Sub-Section 04 (TRANSMISSION AND BRAKE SYSTEMS)

SYMPTOM	VIBRATIONS ORIGINATING FROM DRIVEN PULLEY
CONDITION	NORMAL USE
Test/Inspection	1. Check drive belt. a. Belt width is uneven at many places. <i>Replace (refer to TECHNICAL DATA 09 for the part number).</i>
	2. Check tightening torque of drive pulley screw. a. Moving governor cup. <i>Retighten bolt.</i>
	3. Spring cover bolts. a. Spring cover moves and restrains sliding half movement. <i>Retighten bolts.</i>
	4. Check spring cover (TRA TYPE) and/or outer half bushings. a. Excessive gap between bushings and inner half shaft, thus restraining sliding half movements. <i>Replace bushing(s).</i>
	5. Check sliding half slider shoes. a. Worn slider shoes. <i>Replace.</i>

SYMPTOM	VIBRATIONS ORIGINATING FROM DRIVEN PULLEY
CONDITION	NORMAL USE
Test/Inspection	1. Check sliding half play. a. Sliding half runout. <i>Replace sliding half bushing.</i>
	2. Check sliding half and fixed half straightness. a. Sliding half/fixed half runout. <i>Replace.</i>
	3. Check cam slider shoes. a. One or two slider shoes out of three are broken. <i>Replace.</i>

Section 02 TROUBLESHOOTING

Sub-Section 04 (TRANSMISSION AND BRAKE SYSTEMS)

SYMPTOM	PULLEYS DO NOT DOWN SHIFT PROPERLY
CONDITION	NORMAL USE
Test/Inspection	1. Check driven pulley spring tension. a.Spring tension is too weak. <i>Adjust according to specifications (refer to TECHNICAL DATA 09).</i>
	2. Refer to "Vibrations coming from driven pulley" and check items listed.
	3. Check drive pulley bushings (cleanliness, wear, etc.). a.Bushings stick to fixed half pulley shaft. <i>Clean or replace.</i>
	4. Check driven pulley spring tension. a.Spring tension is too weak. <i>Replace.</i>

SYMPTOM	IT IS DIFFICULT TO ENGAGE TRANSMISSION IN FORWARD OR REVERSE GEAR
CONDITION	NORMAL USE
Test/Inspection	1. Check position of gear shift lever adjustment screw. a.Improper adjustment. <i>Adjust according to specifications (refer to TRANSMISSION 04).</i>

SYMPTOM	UNEVEN BELT WEAR ON ONE SIDE ONLY
CONDITION	NORMAL USE
Test/Inspection  <small>A00D09Y</small>	1. Check tightening torque of engine mount bolts. a.Loose engine mount. <i>Tighten engine mount nuts/bolts equally.</i>
	2. Check pulley alignment. a.Pulley misalignment. <i>Align pulleys.</i>
	3. Check drive belt contact area on pulleys. a.Rough or scratched pulley surfaces. <i>Repair or replace pulley half.</i>
	4. Check driven pulley sliding half play. a.Driven pulley bushing worn. <i>Replace bushing.</i>

Section 02 TROUBLESHOOTING

Sub-Section 04 (TRANSMISSION AND BRAKE SYSTEMS)

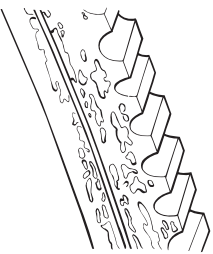
SYMPTOM	BELT GLAZED EXCESSIVELY OR HAVING BAKED APPEARANCE
CONDITION	NORMAL USE
<p>Test/Inspection</p>  <p style="font-size: small;">A00D0AY</p>	<p>1. Check if drive pulley bushings are worn.</p> <p>a. Insufficient pressure on belt sides. <i>Replace bushing.</i></p>
	<p>2. Check condition of drive pulley fixed half shaft.</p> <p>a. Rusted drive or driven pulley shafts. <i>Clean shaft with fine steel wool and lubricate with anti-seize lubricant (if applicable only).</i></p>
	<p>3. Check if pulley halves are clean.</p> <p>a. Oil on pulley surfaces. <i>Clean pulley halves.</i></p>
	<p>4. Check pulley calibration.</p> <p>a. Improper pulley calibration. <i>Calibrate according to specification.</i></p>

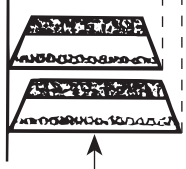
SYMPTOM	BELT WORN EXCESSIVELY IN TOP WIDTH
CONDITION	NORMAL USE
<p>Test/Inspection</p> <p>Considerable use</p>  <p style="font-size: small;">A00D0BY</p>	<p>1. Check drive pulley.</p> <p>a. Excessive slippage due to irregular outward actuation movement of drive pulley. <i>Carry out drive pulley inspection.</i></p>
	<p>2. Check drive belt identification number.</p> <p>a. Improper belt angle. (wrong type of belt). <i>Replace belt with an appropriate drive belt.</i></p>
	<p>3. Check drive belt width.</p> <p>a. Considerable use. <i>Replace belt if 3 mm (1/8") less than recommended width (refer to TECHNICAL DATA 09).</i></p>

Section 02 TROUBLESHOOTING

Sub-Section 04 (TRANSMISSION AND BRAKE SYSTEMS)

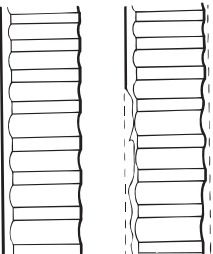
SYMPTOM	BELT WORN NARROW IN ONE SECTION
CONDITION	NORMAL USE
Test/Inspection 	1. Check if parking brake is released. a. Parking brake is engaged. <i>Release parking brake.</i>
	2. Check track tension/alignment. a. Frozen or too tight track. <i>Liberate track from ice or check track tension and alignment.</i>
	3. Check drive pulley. a. Drive pulley not functioning properly. <i>Repair or replace drive pulley.</i>
	4. Check idle speed. a. Engine idle speed too high. <i>Adjust according to specification.</i>
	5. Check drive belt length. a. Incorrect belt length. <i>Replace belt with an appropriate drive belt (refer to TECHNICAL DATA 09).</i>
	6. Check distance between pulleys. a. Incorrect pulley distance. <i>Readjust according to specification.</i>
	7. Check belt deflection. a. Deflection is too small. <i>Adjust according to specification.</i>

A00D0CY

SYMPTOM	BELT SIDES WORN CONCAVE
CONDITION	NORMAL USE
Test/Inspection 	1. Check pulley half surfaces. a. Rough or scratched pulley half surfaces. <i>Repair or replace.</i>
	2. Check drive belt identification number. a. Unspecified type of belt. <i>Replace belt with an appropriate drive belt (refer to TECHNICAL DATA 09).</i>

A00D0DY

Section 02 TROUBLESHOOTING

Sub-Section 04 (TRANSMISSION AND BRAKE SYSTEMS)

SYMPTOM	BELT DISINTEGRATION
CONDITION	NORMAL USE
Test/Inspection	<p>1. Check drive belt identification number.</p> <p>a. Excessive belt speed. <i>Using unspecified type of belt. Replace belt with proper type of belt (refer to TECHNICAL DATA 09).</i></p>
 <p style="font-size: small;">A00D0EY</p>	<p>2. Check if pulley halves are clean.</p> <p>a. Oil on pulley surfaces. <i>Clean pulley surfaces with fine emery cloth and wipe clean using Loctite Safety Solvent (P/N 413 7082 00) and a cloth.</i></p>

SYMPTOM	BELT EDGE CORD BREAKAGE
CONDITION	NORMAL USE
Test/Inspection	<p>1. Check pulley alignment.</p> <p>a. Pulley misalignment. <i>Align pulley according to specifications (refer to TECHNICAL DATA 09).</i></p>
 <p style="font-size: small;">A00D0FY</p>	

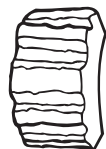
SYMPTOM	FLEX CRACKS BETWEEN COGS
CONDITION	NORMAL USE
Test/Inspection	<p>1. Check drive belt condition.</p> <p>a. Considerable use, belt wearing out. <i>Replace.</i></p>
 <p style="font-size: small;">A00D0GY</p>	

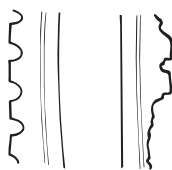
SYMPTOM	SHEARED COGS, COMPRESSION SECTION FRACTURED OR TORN
CONDITION	NORMAL USE
Test/Inspection	<p>1. Check drive belt rotational direction.</p> <p>a. Improper belt installation. <i>Replace.</i></p>
 <p style="font-size: small;">A00D0HY</p>	<p>2. Check if drive belt rubs against components.</p> <p>a. Belt rubbing on stationary object. <i>Relocate components.</i></p>
	<p>3. Check drive pulley.</p> <p>a. Violent engagement of drive pulley. <i>Check drive pulley engagement speed, drive pulley bushings and components.</i></p>

Section 02 TROUBLESHOOTING

Sub-Section 04 (TRANSMISSION AND BRAKE SYSTEMS)

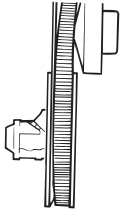
SYMPTOM	BELT "FLIP-OVER" AT HIGH SPEED
CONDITION	NORMAL USE
Test/Inspection 	1. Check pulley alignment. a. Pulley misalignment. <i>Align pulley according to specifications (refer to TECHNICAL DATA 09).</i>
	2. Check drive belt identification number. a. Using unspecified type of belt. <i>Replace belt with an appropriate drive belt.</i>

BRAKE SYSTEM

MECHANICAL BRAKE

SYMPTOM	BRAKE DOES NOT ADJUST AUTOMATICALLY
CONDITION	NORMAL USE
Test/Inspection	1. Check ratchet wheel spring. a. Broken ratchet wheel tag. <i>Replace.</i>
	2. Check mobile pad stud. a. Stud rotates in pad. <i>Replace.</i>

SYMPTOM	BRAKE HANDLE DOES NOT RETURN COMPLETELY
CONDITION	NORMAL USE
Test/Inspection	1. Check brake return spring. a. Broken return spring. <i>Replace.</i>
	2. Check if brake cable moves freely in its housing. a. Brake cable movement is limited due to oxidation or dirt accumulation. <i>Replace.</i>
	3. Check distance between brake lever and caliper. a. Distance is too wide. <i>Adjust according to specifications (refer to TRANSMISSION 04).</i>

HYDRAULIC BRAKE

SYMPTOM	SPONGY BRAKE CONDITION
CONDITION	NORMAL USE
Test/Inspection	<i>Replace brake fluid and bleed system. If problem still occurs, replace master cylinder.</i>

SYMPTOM	BRAKE FLUID LEAKING
CONDITION	NORMAL USE
Test/Inspection	1. Check for loosen hose connectors. <i>Retighten.</i>
	2. Check for damaged hose, master cylinder and caliper. <i>Replace part(s) and check for proper mounting.</i>

MECHANICAL AND HYDRAULIC BRAKES

SYMPTOM	BRAKE SYSTEM IS NOISY
CONDITION	NORMAL USE
Test/Inspection	1. Check brake pad thickness. a.Pads are worn up to wear warner. <i>Replace.</i>

ELECTRICAL SYSTEM

The following chart is provided to help in diagnosing the probable source of troubles. It should be used as a guideline. Some causes or corrections may not apply to a specific model.

SYMPTOM	STARTER DOES NOT TURN
CONDITION	NORMAL USE
Test/Inspection	1. Check fuse. a. Burnt fuse. <i>Check wiring condition and replace fuse.</i>
	2. Check continuity of starter switch contact points. a. Poor contact of starter switch contact points. <i>Repair or replace switch.</i>
	3. Check continuity between starter switch and solenoid. a. Open circuit between starter switch and solenoid switch. <i>Repair.</i>

SYMPTOM	STARTER TURNS; BUT DOES NOT CRANK THE ENGINE
CONDITION	NORMAL USE
Test/Inspection	1. Check battery capacity. a. Shorted battery cell(s). <i>Replace.</i>
	2. Check battery charge. a. Weak battery. <i>Recharge.</i>
	3. Check wire connection. a. Inadequate connection (too much resistance). <i>Clean and reconnect.</i>
	4. Check solenoid switch contact disc. a. Burnt or poor contact of solenoid switch contact disc. <i>Replace solenoid switch.</i>
	5. Check continuity of solenoid switch pull-in winding. a. Open circuit of solenoid switch pull-in winding. <i>Replace solenoid switch.</i>
	6. Check continuity of solenoid switch hold-in winding. a. Open circuit of solenoid switch hold-in winding. <i>Replace solenoid switch.</i>

Section 02 TROUBLESHOOTING

Sub-Section 05 (ELECTRICAL SYSTEM)

	<p>7. Check brushes. a.Poor contact of brushes. <i>Replace brushes.</i></p>
	<p>8. Check commutator. a.Burnt commutator. <i>Turn commutator on lathe.</i></p>
	<p>9. Check height of commutator mica. a.Commutator mica too high. <i>Undercut mica.</i></p>
	<p>10. Check field coil resistance. a.Shorted field coil. <i>Repair or replace yoke.</i></p>
	<p>11. Check armature resistance. a.Shorted armature. <i>Repair or replace armature.</i></p>
	<p>12. Check tension of brush springs. a.Weak brush spring tension. <i>Replace springs.</i></p>
	<p>13. Check yoke assembly magnets. a.Weak magnets. <i>Replace yoke assembly.</i></p>
	<p>14. Check if bushings are worn. a.Worn bushings. <i>Replace bushings.</i></p>

SYMPTOM	STARTER TURNS, BUT OVERRUNNING CLUTCH PINION DOES NOT MESH WITH RING GEAR
CONDITION	NORMAL USE
Test/Inspection	<p>1. Check clutch pinion gear. a.Worn clutch pinion gear. <i>Replace clutch.</i></p>
	<p>2. Check clutch. a.Defective clutch. <i>Replace clutch.</i></p>
	<p>3. Check movement of clutch on splines. a.Poor movement of clutch on splines. <i>Clean and correct.</i></p>

Section 02 TROUBLESHOOTING
Sub-Section 05 (ELECTRICAL SYSTEM)

	<p>4. Check clutch bushing. a. Worn clutch bushing. <i>Replace clutch.</i></p>
	<p>5. Check starter bushing. a. Worn starter bushing(s). <i>Replace bushing(s).</i></p>
	<p>6. Check ring gear. a. Worn ring gear. <i>Replace ring gear.</i></p>

SYMPTOM	ELECTRIC STARTER KEEPS TURNING WHEN ENGINE IS STARTED
CONDITION	NORMAL USE
Test/Inspection	<p>1. Check clutch. a. Jammed clutch pinion gear. <i>Replace or clean.</i></p>
	<p>2. Check movement of clutch on splines. a. Clutch is stuck on splines. <i>Clean.</i></p>
	<p>3. Check ignition switch. a. Ignition switch does not return to its ON position or is short-circuited. <i>Adjust retaining screw or replace switch.</i></p>
	<p>4. Check solenoid. a. Shorted solenoid switch winding(s). <i>Replace solenoid switch.</i></p>
	<p>5. Check solenoid switch contacts. a. Melted solenoid switch contacts. <i>Replace solenoid switch.</i></p>
	<p>6. Check starter switch. a. Starter switch returns poorly. <i>Replace ignition switch.</i></p>

SYMPTOM	NOISE OCCURENCE WHEN STARTING ENGINE
CONDITION	NORMAL USE
Test/Inspection	<p>1. Check if ring gear is well mounted to drive pulley inner half. a. Loose and/or broken bolts. <i>Retighten bolts using threadlocker or replace ring gear and drive pulley inner half.</i></p>

Section 02 TROUBLESHOOTING

Sub-Section 05 (ELECTRICAL SYSTEM)

SYMPTOM	ELECTRIC STARTER SOMETIMES DOES NOT WORK WHEN TURNING IGNITION SWITCH
CONDITION	NORMAL USE
Test/Inspection	1. Check battery cables and starter wires. a. Corroded and/or loose connection(s). <i>Clean and/or retighten.</i>
	2. Check fuse. a. Oxidized fuse. <i>Clean.</i>
	3. Check wiring harness connections. a. Oxidized connections. <i>Clean or replace defective terminals.</i>
	4. Check ignition switch. a. Defective contacts in ignition switch. <i>Replace.</i>
	5. Check solenoid of electric starter. a. Shorted solenoid wiring harness or eroded contact washer. <i>Replace.</i>

SYMPTOM	HEADLAMP NOT LIGHTING
CONDITION	WHITE BULB
Test/Inspection	1. Check bulb. a. Gas leak. <i>Replace bulb.</i>
CONDITION	BROKEN ELEMENT
Test/Inspection	1. Check for loose headlamp housing and bulb socket. a. Vibration problem. <i>Tighten headlamp mounting screws. Lock bulb in socket. Replace bulb.</i>
CONDITION	MELTED FILAMENT (ENDS OF ELEMENT HOLDER) AND BLACK BULB
Test/Inspection	1. Check voltage at headlamp at different speeds. It must not be above 15 VAC. NOTE: If quartz halogen bulb is involved, ensure that proper voltage regulator is installed. a. Excessive voltage in lighting circuit. <i>Replace voltage regulator and ensure proper grounding. Retest.</i>

Section 02 TROUBLESHOOTING
Sub-Section 05 (ELECTRICAL SYSTEM)

SYMPTOM	HEADLAMP DIMING
CONDITION	NORMAL USE
Test/Inspection	<p>1. Check voltage at headlamp at different speeds. It must not be below 11 VAC.</p> <p>a. Insufficient voltage in lighting circuit. <i>Replace voltage regulator and retest.</i></p>
	<p>2. Visually inspect wiring harness for damaged and/or melted wires and/or bad wire terminal crimping and/or connections.</p> <p>a. Heating, rotating or sharp part in contact with harness. Improper harness routing. <i>Repair/replace damaged wires and/or terminals. Reroute harness where necessary.</i></p>
	<p>3. On manual start models: Verify regulator ground.</p> <p>a. Rusted or loose retaining screws. <i>Clean, apply lithium grease (LMZ1) and firmly tighten screws.</i></p>
	<p>4. Verify if there is an interconnection between AC and DC current.</p> <p>a. Faulty installation of optional equipment. <i>Find optional equipment connected directly to DC ground (BK wire or chassis) or to any DC hot wire (RD, RD/BL). Disconnect and reconnect to AC current (YL and YL/BK wires).</i></p>
	<p>5. Verify if optional electric accessories are overloading the magneto/generator.</p> <p>a. Excessive electrical load to magneto/generator. <i>Reduce the electrical load by removing excess accessories. Reconnect as recommended by manufacturer.</i></p>
	<p>6. Hot Grips brand: Verify if they were connected in parallel by mistake.</p> <p>a. Excessive electrical load to magneto/generator. <i>Reconnect as recommended by manufacturer.</i></p>
	<p>7. Bombardier heating grips: Verify if the return wires of the elements were grounded to the chassis by mistake.</p> <p>a. Faulty installation of optional equipment. <i>Reconnect as recommended by manufacturer.</i></p>
	<p>8. Verify if heating grips installation overloads the magneto/generator capacity.</p> <p>a. Excessive electrical load to magneto/generator. <i>Reduce the electrical load by removing accessories.</i></p>

Section 02 TROUBLESHOOTING

Sub-Section 05 (ELECTRICAL SYSTEM)

SYMPTOM	FALSE FUEL AND/OR TEMPERATURE GAUGE READINGS
CONDITION	NORMAL USE
Test/Inspection	1. Verify if gauge was connected on DC current by mistake (in case of optional installation). a. Faulty installation of optional equipment. <i>Find optional wires connected directly to DC ground (BK wire to chassis) or to any DC hot wire (RD, RD/BL). Disconnect and reconnect to AC current (YL and YL/BK wires).</i>
	2. Verify sender unit for free movement and/or correct arm position. a. Defective or damaged part. <i>Correct or replace sender unit.</i>
	3. Verify sender unit/gauge wiring harness condition. a. Heating, rotating or sharp part in contact with harness. Improper harness routing. <i>Replace or repair damaged wires. Reroute where necessary.</i>

SYMPTOM	ENGINES DOES NOT START — NO SPARK AT SPARK PLUG
CONDITION	AT ENGINE CRANKING
Test/Inspection	1. Verify spark plug condition. a. Defective, improperly set, worn-out, fouled. <i>Identify source of problem and correct. Replace spark plug.</i>
	2. Verify spark plug cap resistance with an ohmmeter. a. Defective part. <i>Replace cap.</i>
	3. Verify if problem originated from electrical system wiring harness and/or accessories and/or ignition cut-out switches by unplugging the 4-wire connectors between the magneto/generator and the vehicle wiring harness. Check condition of connectors. a. Heating, rotating or sharp part in contact with harness. Improper harness routing. Defective switch(es). Corroded connector terminals. <i>Replace or repair damaged wires. Reroute where necessary. Replace defective switch(es). Clean terminals and apply silicone dielectric grease.</i>
	4. Verify trigger coil resistance with an ohmmeter and connector condition. a. Defective coil. Corroded connector terminals. <i>Replace defective coil. Clean terminals and apply silicone dielectric grease.</i>
	5. Verify condition of ignition coil. a. Mechanically damaged part. Vibration problem. Electrically damaged part. <i>Tighten mounting screws. Replace ignition coil.</i>

Section 02 TROUBLESHOOTING
Sub-Section 05 (ELECTRICAL SYSTEM)

	<p>6. Verify condition of ignition generator coils. a. Mechanically damaged part. Vibration problem. Electrically damaged part. <i>Tighten mounting screws. Replace coils.</i></p>
	<p>7. Verify CDI (Capacitor discharge ignition) module. a. Mechanically damaged part. Vibration problem. Electrically damaged part. <i>Tighten mounting screws. Replace CDI module, retest and verify ignition timing.</i></p>

SYMPTOM	ENGINE STALLS
CONDITION	AT LOW SPEED
Test/Inspection	1. Verify items 4, 5 and 6 above.

SYMPTOM	IRREGULAR ENGINE SPEED
CONDITION	AT HIGH SPEED
Test/Inspection	1. Verify items 4, 5 and 6 above.
CONDITION	AT LOW SPEED
Test/Inspection	<p>1. Verify items 4 and 5 above and trigger coil/flywheel protrusion air-gap. a. Air-gap too large. <i>Readjust air-gap.</i></p>

SYMPTOM	ENGINE IS MISFIRING — ERRATIC SPARK AT SPARK PLUG
CONDITION	RIDING ON WET SNOW
Test/Inspection	<p>1. Verify if spark plug wires and/or spark plug cap seals are sealing-out moisture. a. Defective wires and/or seals. <i>Replace defective part.</i></p> <p>2. Verify if ignition system wiring harness connectors are in good condition and/or are sealing-out moisture. a. Loose connectors, corroded terminals or defective parts. <i>Clean terminals and apply silicone dielectric grease. Replace defective parts.</i></p>
CONDITION	NORMAL USE
Test/Inspection	<p>1. Verify misfiring by observing flash of stroboscopic timing light; unplug connectors between magneto/generator and vehicle wiring harness to isolate problem. Check condition of connectors. a. Defective spark plug and/or cables/caps. Defective electrical system wiring harness and/or accessories and/ignition cut-out switches. Condition of connector terminals. <i>Replace defective parts and/or repair damaged wires. Replace defective switch(es). Clean terminals and apply silicone dielectric grease.</i></p>

Section 02 TROUBLESHOOTING

Sub-Section 05 (ELECTRICAL SYSTEM)

CONDITION	RIDING IN DEEP AND THICK SNOW
Test/Inspection	1. Perform all verifications outlined under “Engine does not start — no spark at spark plug”.
	2. Verify spark plug(s). Proceed with spark plug analysis in order to identify source of problem. a. Defective and/or worn spark plug(s) and/or cable(s) and/or cap(s). <i>Replace defective part(s). Proceed with ignition system testing procedures. Perform engine analysis.</i>

SYMPTOM	FOULED (BLACK) SPARK PLUG TIP
CONDITION	NORMAL USE
Test/Inspection	1. Check carburetor(s). a. Carburetion is too rich. <i>Adjust according to specifications (refer to TECHNICAL DATA 09).</i>
	2. Check injection oil consumption. a. Injection pump flow is too high. <i>Adjust according to specification or replace.</i>
	3. Check oil quality. a. Poor oil quality that creates deposits. <i>Use Bombardier oil.</i>
	4. Check engine compression. a. Leaking piston ring(s). <i>Replace.</i>

SYMPTOM	SPARK PLUG TIP(S) IS (ARE) LIGHT GREY
CONDITION	NORMAL USE
Test/Inspection	1. Refer to “Engine slows down or stops at high RPM” and check items listed.
	2. Check spark plug heat range. a. Spark plug heat range is too high. <i>Replace by Bombardier’s recommended spark plug (refer to TECHNICAL DATA 09).</i>
	3. Check if air intake silencer leaks. a. Air surplus coming from opening(s) located between halves. <i>Seal.</i>
	4. Check carburetor adapter collars. a. Loose collar(s). <i>Tighten.</i>
	5. Check carburetor adapter(s). a. Cracked or deformed adapter(s). <i>Replace.</i>

Section 02 TROUBLESHOOTING
Sub-Section 05 (ELECTRICAL SYSTEM)

SYMPTOM	BRAKE LIGHT REMAINS ON
CONDITION	NORMAL USE
Test/Inspection	<p>1. Check if bulb is properly installed. a. Bulb is not installed correctly (contact elements are reversed). <i>Install bulb correctly.</i></p> <p>2. Check brake switch. a. Switch contact remains closed. <i>Adjust brake cable or brake switch.</i></p>

SYMPTOM	REAR LIGHT BULB FLASHES
CONDITION	NORMAL USE
Test/Inspection	<p>1. Check bulb tightness in housing. a. Looseness at bulb contact elements. <i>Install bulb correctly.</i></p> <p>2. Check if rear light is properly connected. a. Connector housing is partially connected. <i>Install connector housing properly.</i></p> <p>3. Check continuity of wires. a. Corroded terminals and/or broken wires. <i>Replace terminal(s) or crimp defective wires.</i></p>

SYMPTOM	TACHOMETER DOES NOT WORK
CONDITION	NORMAL USE
Test/Inspection	<p>1. Check continuity of wires. a. Corroded terminals and/or broken wires. <i>Replace terminal(s) or crimp defective wires.</i></p>

SUSPENSION SYSTEM AND TRACK

The following chart is provided to help in diagnosing the probable source of troubles. It should be used as a guideline. Some causes or corrections may not apply to a specific model.

SYMPTOM	REAR SUSPENSION BOTTOMS OUT
CONDITION	NORMAL USE
Test/Inspection	<p>1. Check rear spring preload or rear arm spring preload.</p> <p>a.Spring tension is too low. <i>Increase rear arm spring preload.</i></p>

SYMPTOM	SLIDER SHOES WEAR OUT PREMATURELY
CONDITION	NORMAL USE
Test/Inspection	<p>1. Check track tension.</p> <p>a.Pressure is too great on slider shoes. <i>Adjust according to specifications (refer to TECHNICAL DATA 09). Replace defective parts.</i></p>

SYMPTOM	TRACK CLEATS BECOME BLUE
CONDITION	NORMAL USE
Test/Inspection	<p>1. Check track tension.</p> <p>a.Pressure is too great on cleats. <i>Adjust according to specifications (refer to TECHNICAL DATA 09).</i></p> <p>2. Check slider shoes and/or suspension retaining screws.</p> <p>a.Worn slider shoes or lost retaining screws. <i>Replace defective parts and/or tighten loose screws.</i></p>

SYMPTOM	NOISE OR VIBRATIONS ORIGINATING FROM THE TRACK
CONDITION	NORMAL USE
Test/Inspection	<p>1. Check slide suspension retaining bolts.</p> <p>a.Missing bolt(s) allowing movement of certain components which in turn interfere with track rotation. <i>Replace missing bolt(s).</i></p> <p>2. Check condition of idler wheel(s).</p> <p>a.Idle wheel rubber is damaged. <i>Replace.</i></p> <p>3. Check guide cleats.</p> <p>a.Top portion of guide cleat(s) is bent. <i>Replace.</i></p> <p>4. Check sprockets.</p> <p>a.One or various teeth of drive shaft sprockets are broken. <i>Replace sprocket(s).</i></p>

Section 02 TROUBLESHOOTING

Sub-Section 06 (SUSPENSION SYSTEM AND TRACK)

	<p>5. Check track rods and/or internal traction teeth. a. One or various track rods and/or teeth are broken. <i>Replace track.</i></p>
--	-------------------------------------------------------------------------------------------------------------------------------------------------------

SYMPTOM	DERAILING TRACK
CONDITION	NORMAL USE
Test/Inspection	<p>1. Check track tension. a. Track is too loose. <i>Adjust.</i></p>
	<p>2. Check if track and slider shoes are properly aligned. a. Improper alignment. <i>Adjust.</i></p>

SYMPTOM	REAR SUSPENSION IS LOW OR TOO STIFF
CONDITION	NORMAL USE
Test/Inspection	<p>1. Check track tension. a. Track is too tight. <i>Adjust.</i></p>
	<p>2. Check if axles are properly lubricated. a. Improper lubrication and/or contaminated grease (sticky oil sludge). <i>Clean and/or lubricate.</i></p>
	<p>3. Check rear spring preload. a. Insufficient preload. <i>Increase preload using shock adjustment cams.</i></p>

SYMPTOM	WHEN HANDLEBAR IS TURNED, SNOWMOBILE UNDERSTEERS
CONDITION	NORMAL USE
Test/Inspection	<p>1. Check ski runner condition. a. Worn ski runners. <i>Replace.</i></p>
	<p>2. Check tension of front spring adjustment cams. a. Insufficient ski pressure on the ground. <i>Increase spring preload.</i></p>
	<p>3. Check if front arm stopper strap is too long. a. Insufficient ski pressure on the ground. <i>Shorten stopper strap.</i></p>
	<p>4. Check front arm spring tension. a. Insufficient ski pressure on the ground. <i>Slacken spring tension.</i></p>

Section 02 TROUBLESHOOTING

Sub-Section 06 (SUSPENSION SYSTEM AND TRACK)

SYMPTOM	HANDLE BAR IS DIFFICULT TO TURN
CONDITION	NORMAL USE
Test/Inspection	<p>1. Check position of front spring adjustment cams.</p> <p>a. More pressure on the ground when cam increases spring preload. <i>Reduce front spring preload.</i></p>
	<p>2. Check position of stopper strap.</p> <p>a. More weight when stopper strap is short. <i>Lengthen front arm stopper strap.</i></p>
	<p>3. Check position of front arm shock adjustment cam(s).</p> <p>a. When spring tension is weak, more weight is transferred to the skis. <i>Increase spring preload.</i></p>
	<p>4. Check condition of ball joints.</p> <p>a. Corrosion restrains movement. <i>Lubricate or replace.</i></p>
	<p>5. Check swing arm camber (liquid cooled models).</p> <p>a. Too much ski leg inclination. <i>Adjust camber to $0^{\circ} \pm .5^{\circ}$.</i></p>

SYMPTOM	THE SNOWMOBILE IS UNSTABLE (IT MOVES FROM LEFT TO RIGHT AND VICE VERSA)
CONDITION	NORMAL USE
Test/Inspection	<p>1. Check ski runner condition.</p> <p>a. Worn or bent ski runners. <i>Replace ski runners.</i></p>
	<p>2. Check ski alignment.</p> <p>a. Improper ski alignment. <i>Align skis in order to obtain proper toe-out (opening) (to adjust, refer to STEERING SYSTEM 07).</i></p>
	<p>3. Check if bushings are too loose in steering system.</p> <p>a. Bushings are too loose. <i>Replace.</i></p>

TABLE OF CONTENTS

599, 699 AND 809 ENGINE TYPES	03-02-1
ENGINE REMOVAL AND INSTALLATION	03-02-1
REMOVAL FROM VEHICLE	03-02-2
INSTALLATION ON VEHICLE	03-02-2
TOP END	03-02-3
COMPONENT REMOVAL	03-02-4
CLEANING	03-02-4
DISASSEMBLY	03-02-4
INSPECTION	03-02-5
ASSEMBLY	03-02-5
BOTTOM END	03-02-9
CLEANING	03-02-10
DISASSEMBLY	03-02-10
INSPECTION	03-02-10
ASSEMBLY	03-02-11
LEAK TEST AND ENGINE DIMENSION MEASUREMENT	03-03-1
LEAK TEST	03-03-1
PREPARATION	03-03-1
PROCEDURE	03-03-1
FINALIZING REASSEMBLY	03-03-4
COOLING SYSTEM LEAK TEST	03-03-4
ENGINE LEAK VERIFICATION FLOW CHART	03-03-5
ENGINE DIMENSION MEASUREMENT	03-03-6
CYLINDER TAPER	03-03-6
CYLINDER OUT OF ROUND	03-03-6
CYLINDER/PISTON CLEARANCE	03-03-6
RING/PISTON GROOVE CLEARANCE	03-03-7
RING END GAP	03-03-7
CRANKSHAFT DEFLECTION	03-03-7
CONNECTING ROD BIG END AXIAL PLAY	03-03-8
CONNECTING ROD/PISTON PIN CLEARANCE	03-03-8
CONNECTING ROD/CRANKPIN CLEARANCE	03-03-9
CRANKSHAFT END-PLAY	03-03-9
CHECKING SURFACE FLATNESS	03-03-9
RECTIFYING SURFACES	03-03-9
CHECKING CRANKSHAFT ALIGNMENT	03-03-9
CDI SYSTEM	03-04-1
NIPPONDENSO TRIGGER COIL IGNITION SYSTEM	03-04-1
CLEANING	03-04-2
DISASSEMBLY	03-04-2
ASSEMBLY	03-04-4

Section 03 ENGINE

Sub-Section 01 (TABLE OF CONTENTS)

OIL INJECTION SYSTEM	03-05-1
OIL INJECTION PUMP	03-05-1
OIL PUMP IDENTIFICATION	03-05-2
CLEANING	03-05-2
DISASSEMBLY	03-05-2
ASSEMBLY	03-05-2
ADJUSTMENT.....	03-05-2
CHECKING OPERATION	03-05-4
LIQUID COOLING SYSTEM	03-06-1
INSPECTION	03-06-2
DRAINING THE SYSTEM.....	03-06-2
DISASSEMBLY AND ASSEMBLY	03-06-2
COOLING SYSTEM REFILLING PROCEDURE	03-06-3
REWIND STARTER	03-07-1
REMOVAL	03-07-2
DISASSEMBLY	03-07-2
ASSEMBLY	03-07-2
INSTALLATION	03-07-4
CARBURETOR AND FUEL PUMP	03-08-1
REMOVAL	03-08-3
CLEANING AND INSPECTION	03-08-3
IDENTIFICATION	03-08-3
DISASSEMBLY AND ASSEMBLY.....	03-08-4
CARBURETOR FLOAT LEVEL ADJUSTMENT.....	03-08-5
INSTALLATION	03-08-6
CARBURETOR ADJUSTMENTS.....	03-08-7
PRELIMINARY IDLE SPEED ADJUSTMENT	03-08-10
IDLE SPEED FINAL ADJUSTMENT.....	03-08-10
CHOKE	03-08-10
FUEL PUMP	03-08-14
REMOVAL	03-08-15
PUMP VERIFICATION.....	03-08-15
CLEANING AND INSPECTION	03-08-15
INSTALLATION	03-08-15
FUEL TANK AND THROTTLE CABLE	03-09-1

599, 699 AND 809 ENGINE TYPES

ENGINE REMOVAL AND INSTALLATION

All Models

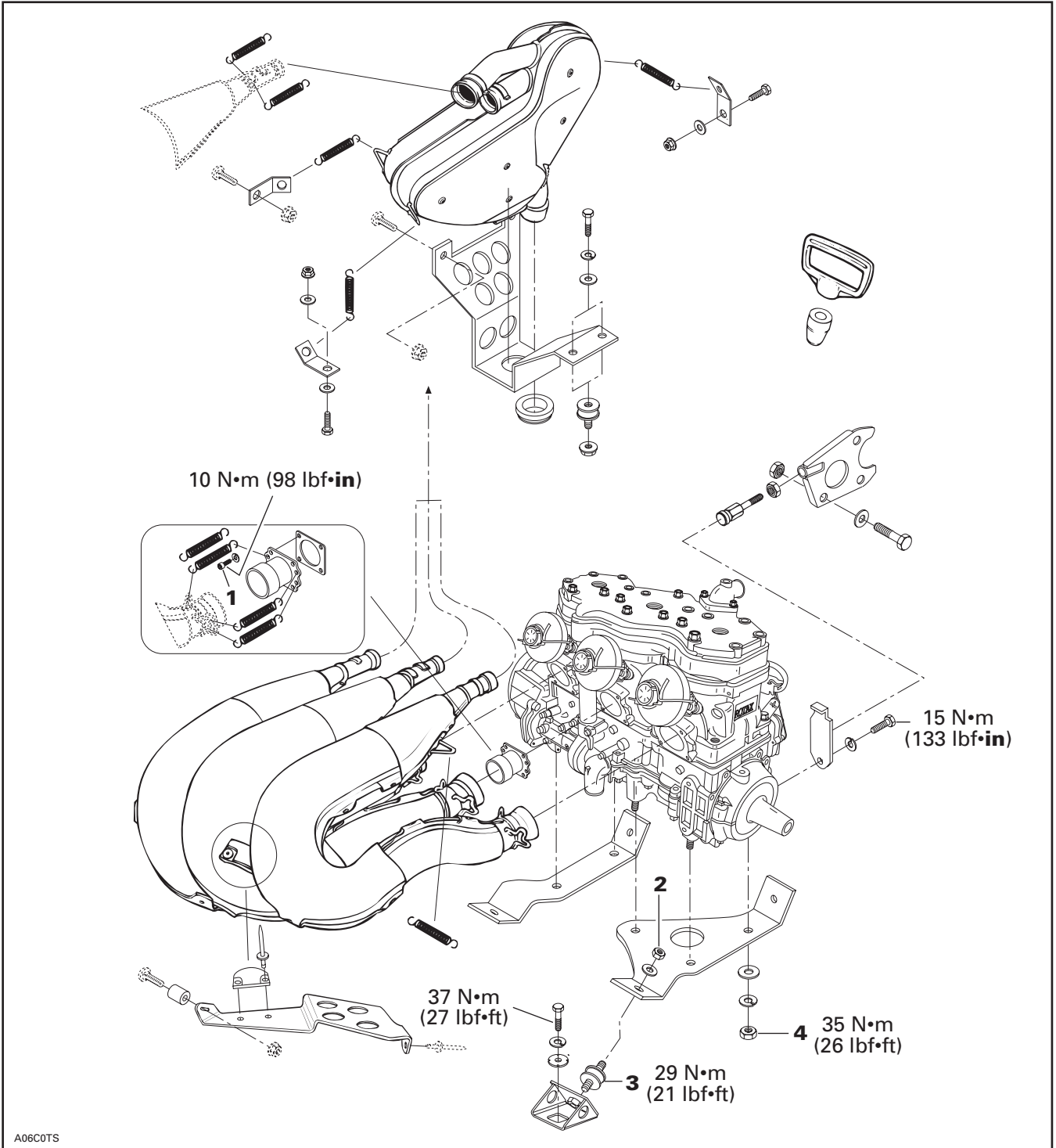

Section 03 ENGINE

Sub-Section 02 (599, 699 AND 809 ENGINE TYPES)

REMOVAL FROM VEHICLE

Remove or unplug the following then lift off engine from engine compartment.

NOTE: 3-cylinder engine is more heavy than a 2 cylinder engine. It weights about 45 kg (100 lb). Use of a hoist is recommended.

- belt guard
- drive belt
- drive pulley
- air intake silencers
- carburetors
- exhaust pipes
- after muffler
- wiring connections
- coolant
- rewind starter
- CDI box from accessory support
- oil injection inlet line at oil injection pump
- coolant hoses
- engine support screws
- engine stopper (left rear of engine)
- impulse lines from engine

1,2,3,4, Engine Support Nut and Manifold Screw

Torque the engine/support nuts to 35 N•m (26 lbf•ft).

Torque rubber mount/support bracket to 29 N•m (21 lbf•ft).

Torque rubber mount/support nuts to 37 N•m (27 lbf•ft).

Torque manifold screws to 10 N•m (89 lbf•in).

INSTALLATION ON VEHICLE

To install engine on vehicle, reverse removal procedure. However, pay attention, to all appropriate component/system reinstallation procedures described throughout this *Shop Manual* and to the following:

- After throttle cable installation, check carburetor maximum throttle opening and oil injection pump adjustment.
- Check pulley alignment and drive belt tension.
- Should as light exhaust leak be experienced at muffler ball joint, Dow Corning sealer no. 736 RTV (P/N 413 7092 00) can be used.

TOP END

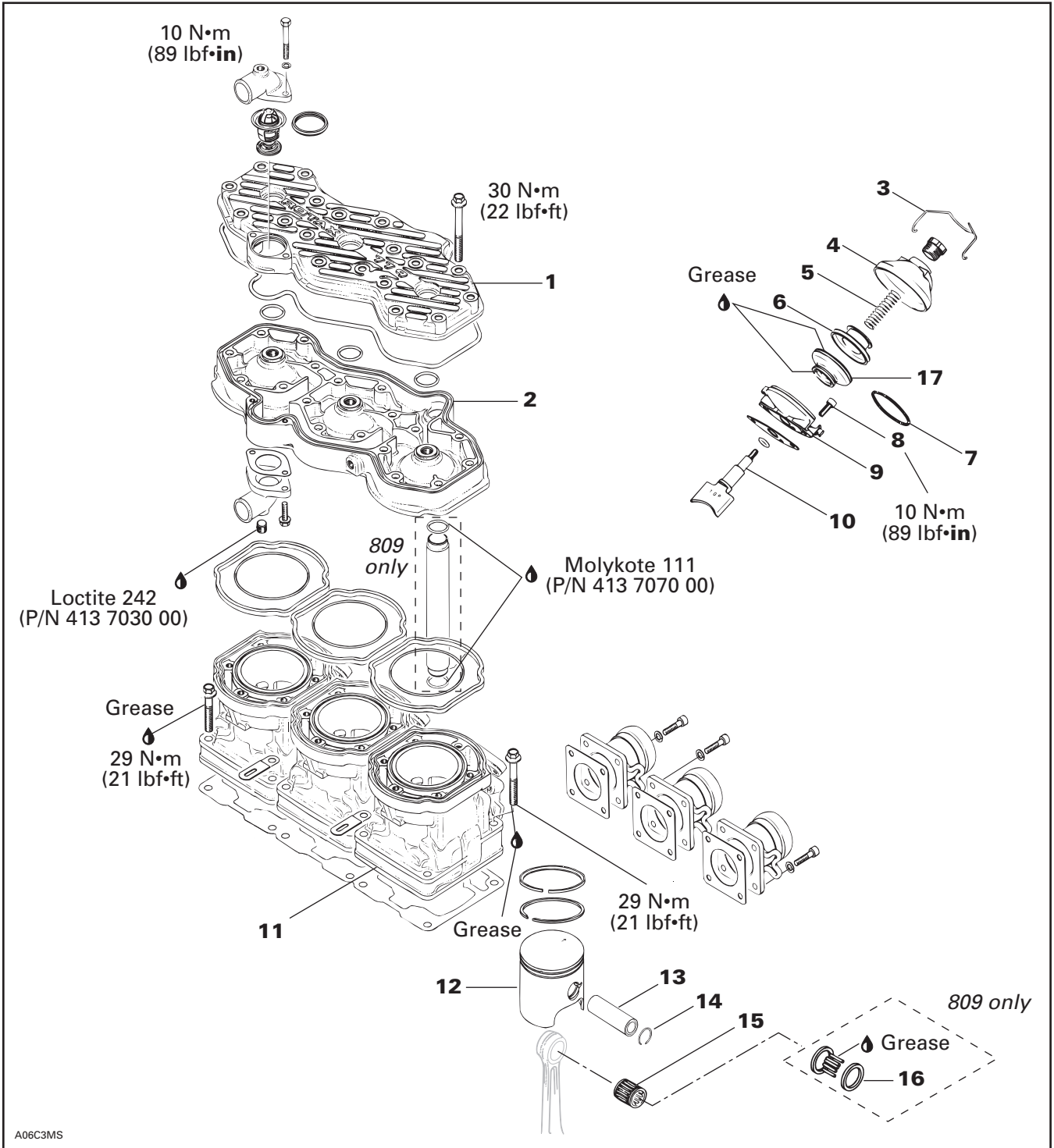

Section 03 ENGINE

Sub-Section 02 (599, 699 AND 809 ENGINE TYPES)

COMPONENT REMOVAL

Most engine components can be removed with engine on vehicle such as:

- cylinder head
- piston(s)
- cylinder(s)
- rewind starter
- oil pump
- water pump
- magneto flywheel
- rave valve(s)

CLEANING

Discard all gaskets and O-rings.

Clean all metal components in a non-ferrous metal cleaner.

Scrape off carbon formation from cylinder exhaust port cylinder head and piston dome using a wooden spatula.

NOTE: The letters "AUS" (over an arrow on the piston dome) must be visible after cleaning.

Clean the piston ring groove with a groove cleaner tool or with a piece of broken ring.

DISASSEMBLY

12, Piston

599 and 699 Engines

Place a clean cloth over crankcase then with a pointed tool inserted in piston notch, remove circlip no. 14 from piston no. 12.

Use piston pin puller (P/N 529 0210 00).

Unscrew puller in order to remove piston pin no. 14 and cage bearing no. 15 from piston.

Remove piston from connecting rod.

809 Engine

On this engine, piston pin needle bearing no. 16 is mounted without a cage.

Use piston pin puller (P/N 529 0210 00) along with expansion sleeve and locating sleeve.

Place a clean cloth or rubber pad (P/N 529 0234 00) over crankcase to prevent circlips no. 14 from falling into crankcase. Then with a pointed tool inserted in piston notch, remove circlips from piston no. 12.

Insert piston pin puller (P/N 529 0210 00) then install expansion sleeve over puller rod.

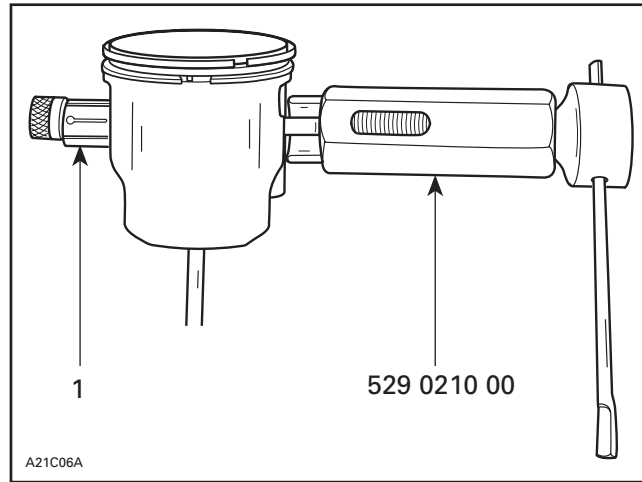

1. Expansion sleeve

Pull out piston pin no. 13 by unscrewing puller until first thread of puller rod aligns with the mark.

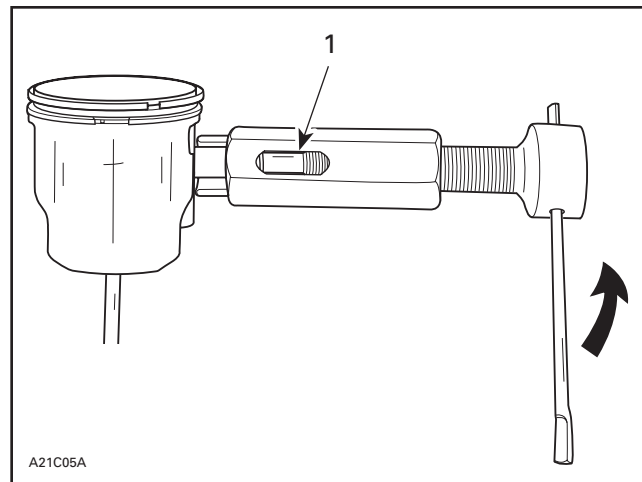

1. Mark on puller

Screw in puller in order to remove it from piston.

Remove piston from connecting rod.

Install locating sleeve. Then push needle bearings along with thrust washers using a 21 mm (.826 in) diameter pusher.

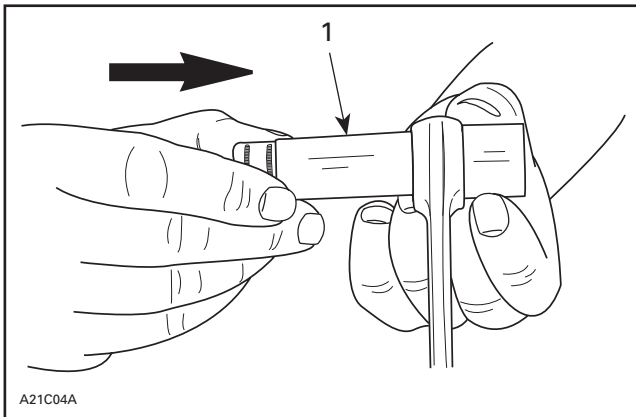

1. Pusher 21mm (.826 in)

RAVE System

NOTE: RAVE stands for Rotax Adjustable Variable Exhaust.

Remove spring clip no. 3, cover no. 4 and spring no. 5.

Remove spring no. 7 then unscrew valve piston no. 6.

Remove cylindrical screws no. 8 then valve rod housing no. 9.

Pull out exhaust valve no. 10.

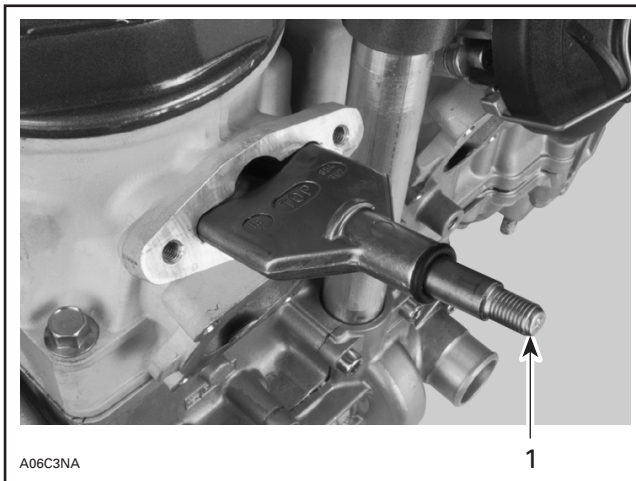

1. Exhaust valve

INSPECTION

NOTE: Refer to LEAK TEST AND ENGINE DIMENSIONS MEASUREMENT 03-03.

RAVE System

Check valve rod housing and cylinder for clogged passages.

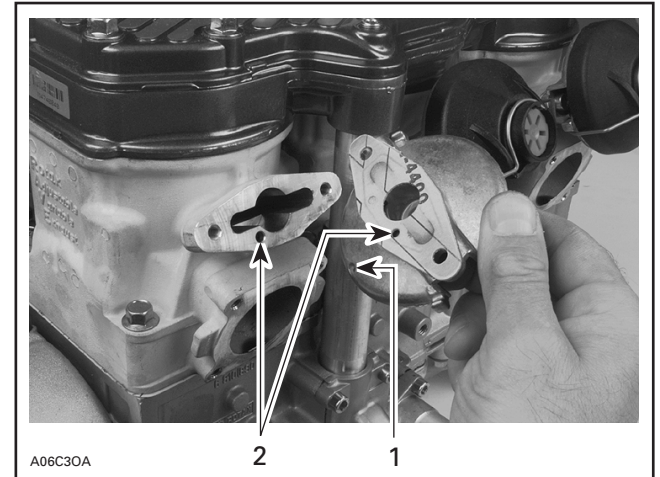

1. Draining hole
2. Passages

NOTE: Oil dripping from draining hole indicates a loosen clamp or damaged bellows.

17, Bellows

Check for cracked, dried or perforated bellows.

5, Spring

ENGINE TYPE	SPRING P/N	WIRE DIA.	FREE LENGTH	PRELOAD IN N (LBF) AT COMPRESSED LENGTH OF 14.7 mm (.579 in)
		mm (in)	mm (in)	
599	420	0.8	48.5	0.0100 (.00224)
	2399 40	(.031)	(1.91)	
699 and 809	420	0.9	48.5	0.0169 (.0038)
	2399 44	(.031)	(1.91)	

ASSEMBLY

RAVE System

Install rave valve with its mention top as illustrated in the removal photo. Tighten red cap screw to bottom.

11,12, Cylinder and Piston

NOTE: Be sure to restore the chamfer around all cylinder sleeve port openings.

Before inserting piston in cylinder, lubricate the cylinder with new injection oil or equivalent.

Section 03 ENGINE

Sub-Section 02 (599, 699 AND 809 ENGINE TYPES)

1,2,11, Cylinder Head Cover, Cylinder Head and Cylinder

Check flatness of part sealing surfaces.

Refer to LEAK TEST AND ENGINE DIMENSION MEASUREMENT 03-03 and look for **Checking Surface Flatness**.

- Mount piston over connecting rod with the letters "AUS" (over an arrow on the piston dome) facing in the direction of exhaust port (see illustration below).

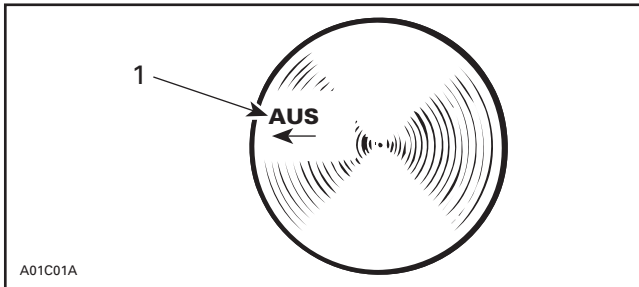

1. Exhaust

599 and 699 Engines

- Install piston pin puller (P/N 529 0210 00) and turn handle until piston pin is correctly positioned in piston.

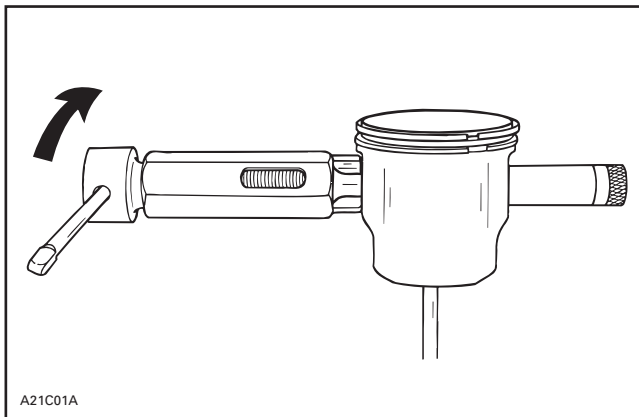

- Remove piston pin puller.

809 Engine

When reinstalling original needle bearings, make sure that 31 needles are inserted between expansion sleeve and locating sleeve.

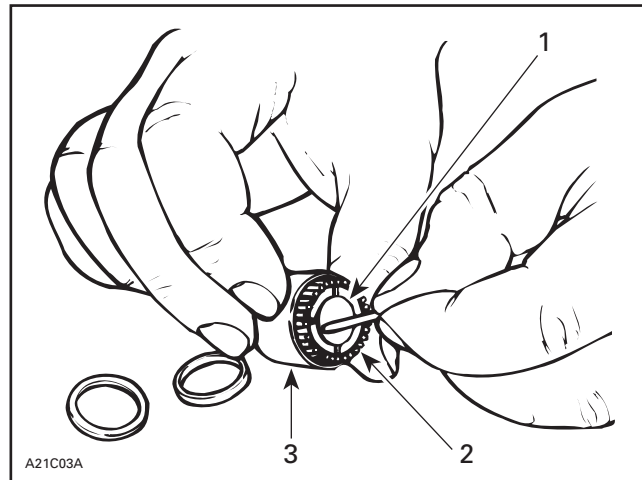

1. Expansion sleeve
2. 31 needles
3. Locating sleeves

- Grease thrust washers and install them on each end of needles.
- Using a 21 mm (.826 in) diameter pusher, insert needles into connecting rod.

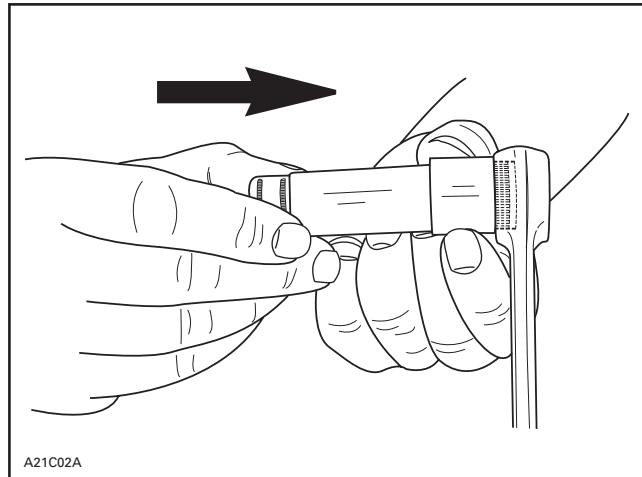

Mount piston over connecting rod with the letters "AUS" (over an arrow on the piston dome) facing in the direction of exhaust port.

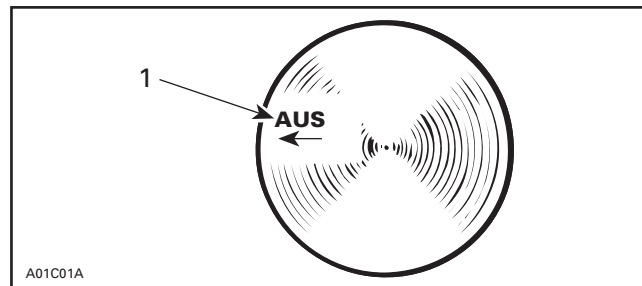

1. Exhaust

Install piston pin puller (P/N 529 0210 00) and turn handle until piston pin is correctly positioned in piston.

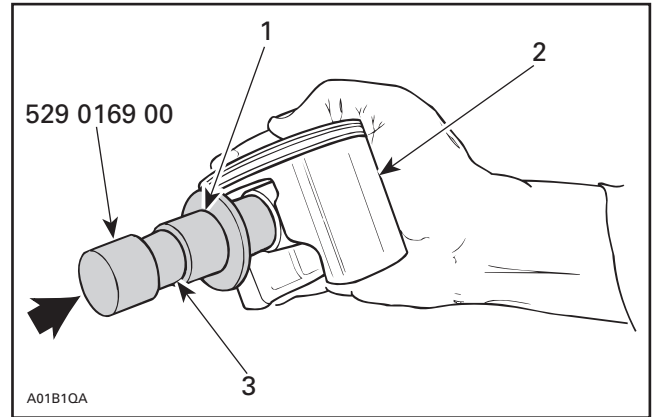
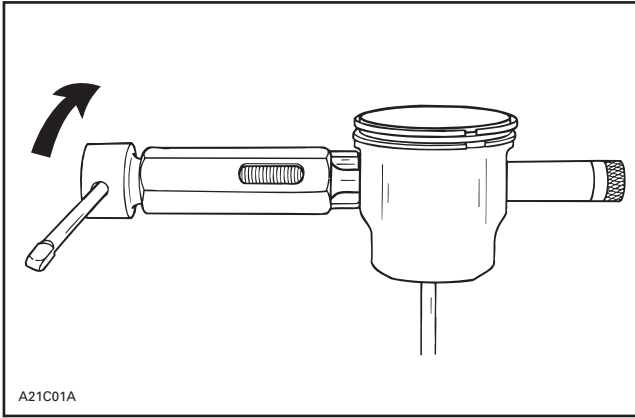

TYPICAL
 1. Place circlip in
 2. Restrain
 3. Oil

Remove piston pin puller and expansion sleeve.

When installing new needle bearing, insert needles with thrust washers. Instead of expansion sleeve, needles are held in place by 2 inner plastic cage halves.

Use piston pin puller (P/N 529 0210 00) to insert piston pin. Plastic halves should come off piston. If not, pull them using long nose pliers.

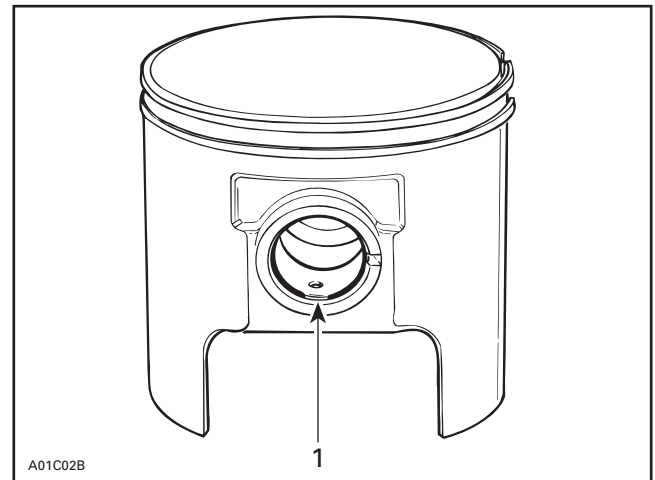
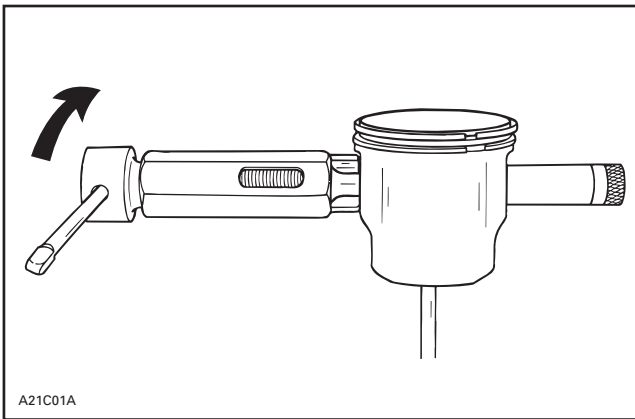

TYPICAL
 1. Circlip break

▼ CAUTION

Circlips must not move freely after installation if so, replace them.

All Engines

To minimize the effect of acceleration forces on circlip, install each circlip so the circlip break is at 6 o'clock as illustrated. Use piston circlip installer (P/N 529 0169 00).

Install cylinders and check for same height.

Section 03 ENGINE

Sub-Section 02 (599, 699 AND 809 ENGINE TYPES)

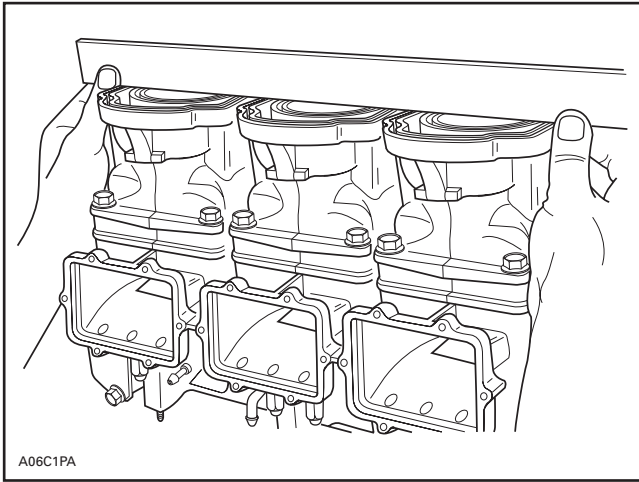

Also check for proper cylinder alignment.

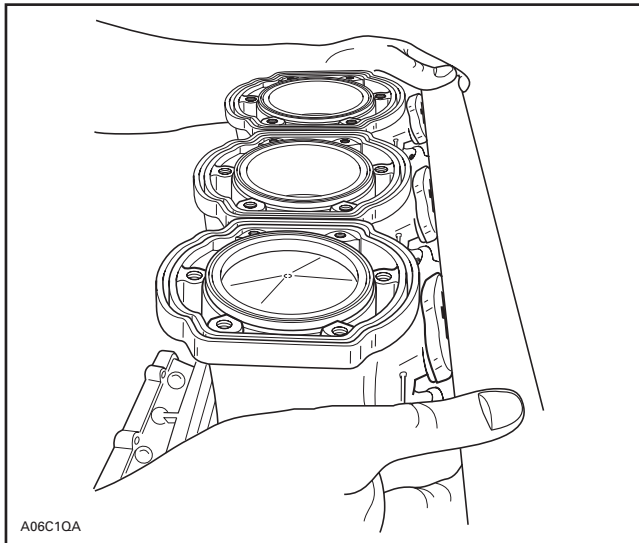

At assembly, torque cylinder head screws in the following illustrated sequence. Tightening torques are:

M6 screws: 12 N•m (106 lbf•in)

M8 screws: 30 N•m (22 lbf•ft)

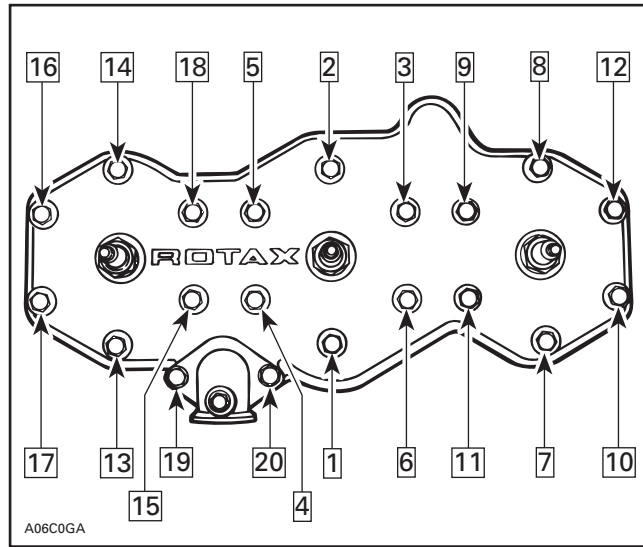

TYPICAL

BOTTOM END

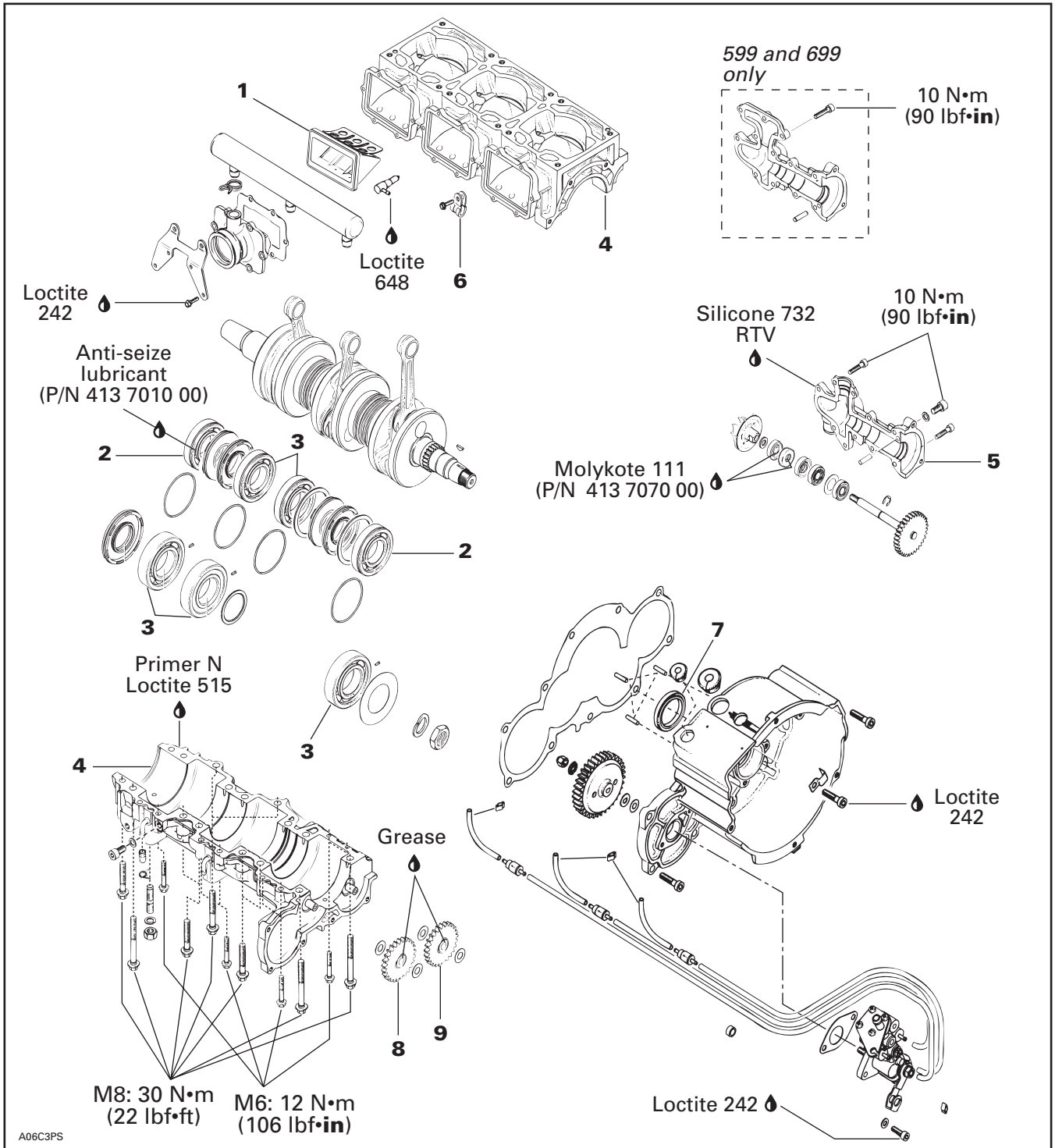

Section 03 ENGINE

Sub-Section 02 (599, 699 AND 809 ENGINE TYPES)

NOTE: Engine must be removed from chassis to perform the following procedures.

CLEANING

Discard all oil seals, gaskets, O-rings and sealing rings.

Clean all metal components in a non-ferrous metal cleaner. Use gasket remover (P/N 413 7085 00) accordingly.

Remove old paste gasket from crankcase mating surfaces with Bombardier gasket remover (P/N 413 7085 00).

▼ CAUTION

Never use a sharp object to scrape away old sealant as score marks incurred are detrimental to crankcase sealing.

DISASSEMBLY

General

To remove drive pulley, refer to DRIVE PULLEY 04-03.

To remove magneto, refer to CDI MAGNETO 03-04.

2,3, Crankshaft Bearing

To remove bearings from crankshaft, use a protective cap and special puller, as illustrated.

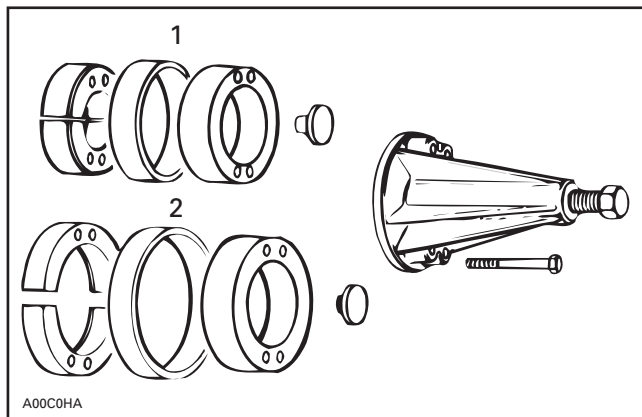

1. PTO side
2. MAG side

INSPECTION

NOTE: Refer to LEAK TEST AND ENGINE DIMENSIONS MEASUREMENT 03-03.

1, Reed Valve

With blade stopper removed, check reed valve for proper tightness. There must be no play between blade and valve body when exerting a finger pressure on blade at blade stopper location.

In case of a play, turn blade up side down and re-check. If there is still a play, replace blade and/or valve body.

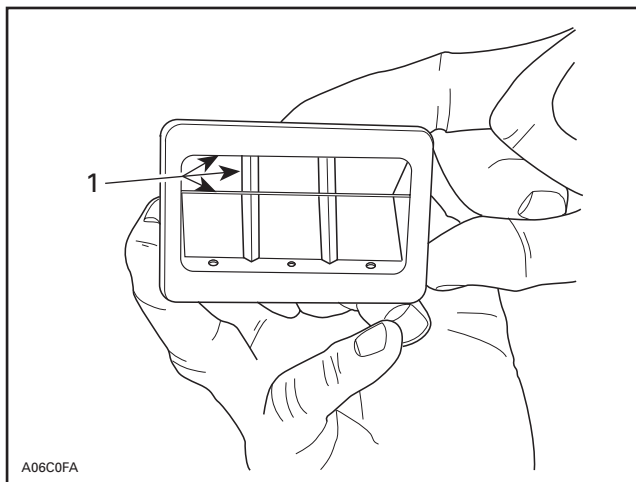

1. No play

Check blade stopper distance from center of reed valve block.



TYPICAL

- A. 599 Engine: 14 ± 0.25 mm (.551 \pm .010 in)
699 Engine: 12 ± 0.25 mm (.472 \pm .010 in)
809 Engine: 12 ± 0.25 mm (.472 \pm .010 in)

Bent blade stopper as required to obtain the proper distance.

ASSEMBLY

2,3, Crankshaft Bearing, Anti-seize Lubricant and Labyrinth Sleeve

Smear anti-seize lubricant (P/N 413 7010 00) on part of crankshaft where bearing fits.

Prior to installation, place bearings into an oil container filled with oil previously heated to 75°C (167°F). This will expand bearing and ease installation.

809 Engine Only

Last PTO bearing is 8 mm (5/16 in) from inner bearing.

4, Crankcase

At crankshaft installation, position drive pins as illustrated.

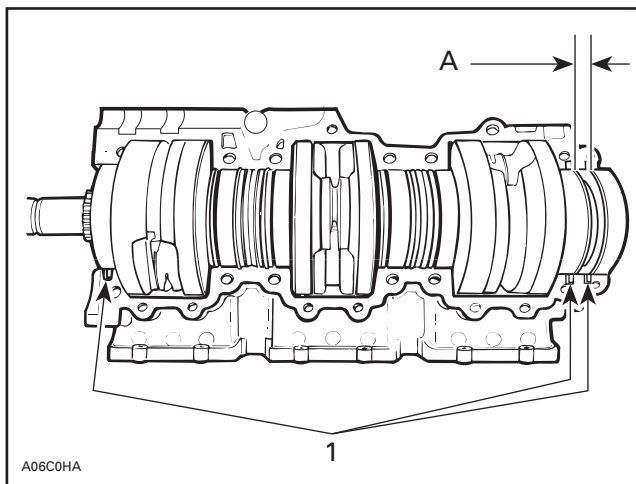

809 ENGINE

- 1. Drive pins
- A. 8 mm (5/16 in)

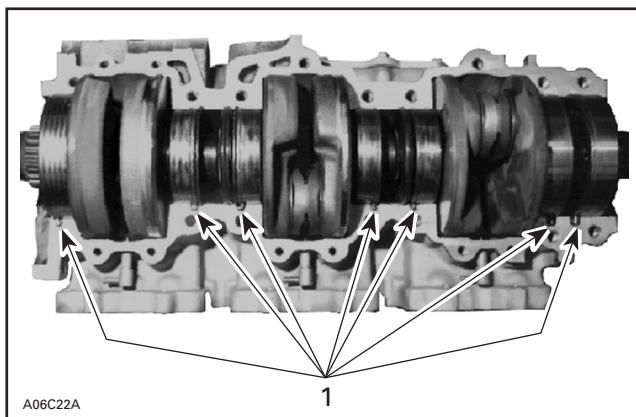

599 AND 699 ENGINES

- 1. Drive pins

Crankcase halves **no. 4** and water pump housing are factory matched and therefore, are not interchangeable as single halves.

Prior to joining of crankcase halves, spray some new injection oil (or equivalent) on all moving parts of the crankshaft. Spray Primer N (P/N 413 7081 00) on one of mating surfaces. Let it dry for 10 to 20 minutes.

Apply paste gasket (P/N 413 7027 00) on the other mating surface.

NOTE: Primer N allows Loctite 515 to fully cure on aluminum surfaces. It increases filling capacity and reduce curing time.

Torque crankcase screws in the following illustrated sequence. Tightening torques are:

M6 screws: 12 N•m (106 lbf•in)

M8 screws: 30 N•m (22 lbf•ft)

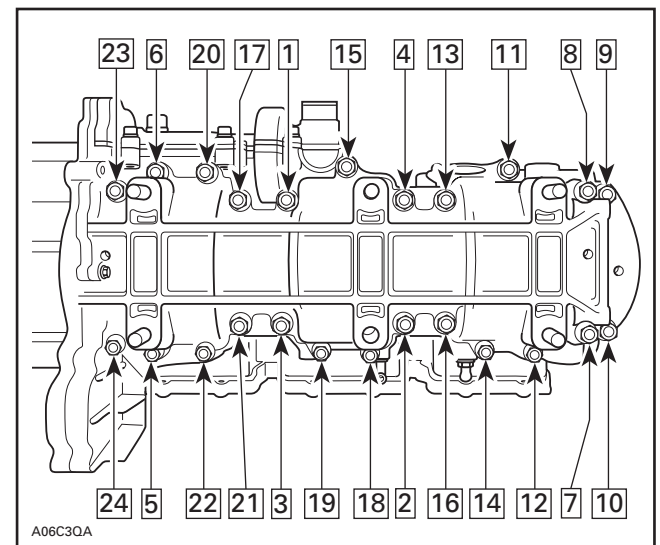

TYPICAL

5, Water Pump Housing

Apply silicone 732 RTV on sealing surface.

Tighten water pump housing screws to 10 N•m (90 lbf•in) following sequence as illustrated.

Section 03 ENGINE

Sub-Section 02 (599, 699 AND 809 ENGINE TYPES)

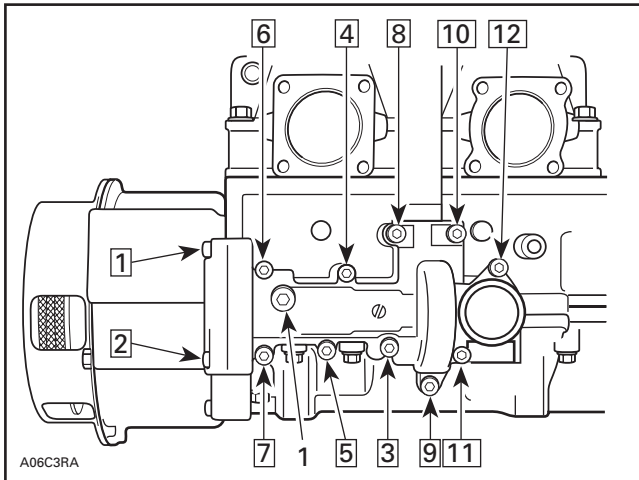

809 ENGINE

1. Oil level plug

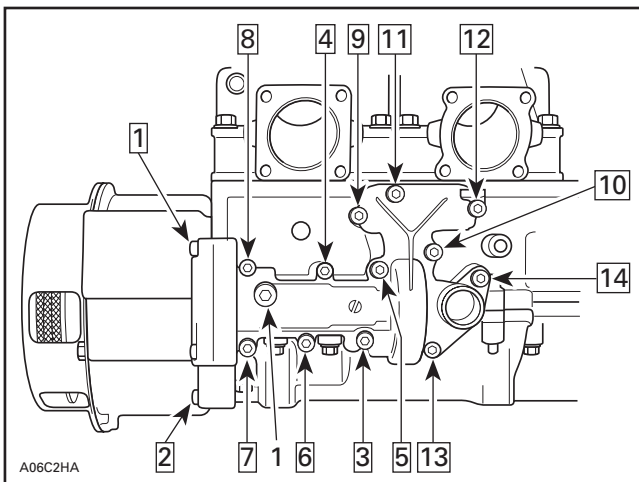

599 AND 699 ENGINES

1. Oil level plug

Add chaincase synthetic oil (P/N 413 8028 00) into water pump housing until oil level reach bottom of plug hole. See above illustration. Total capacity is about 14 cc (.47 US oz).

This oil addition is needed only when servicing water pump. During normal engine operation, this oil can flow through engine. After that fuel/oil mixture will lubricate water pump bearings by scavenging.

6, Screw

Apply Loctite 242 on screw threads. Install the screw retaining oil line clip first. If experiencing leaks at carburetor adaptor, use primer N and Loctite 515 on sealing surfaces of crankcase and adaptor.

7, Seal

Install seal using pusher (P/N 420 8765 16).

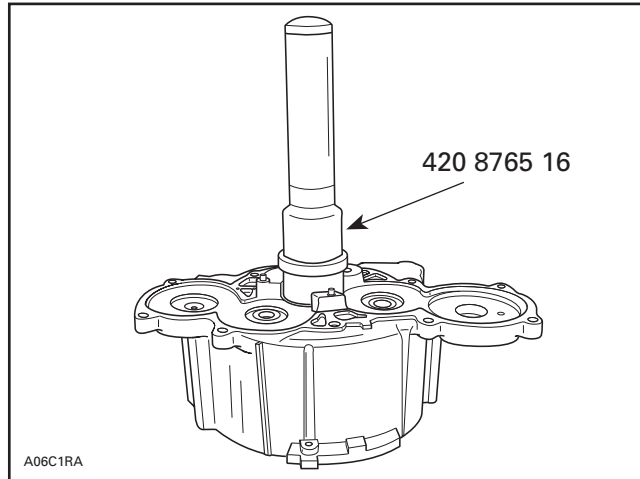

8,9, Plastic Gear and Steel Gear

Apply grease to needle bearing of each gear.

Install plastic gear on oil pump side. Steel gear goes on water side, its shoulder first.

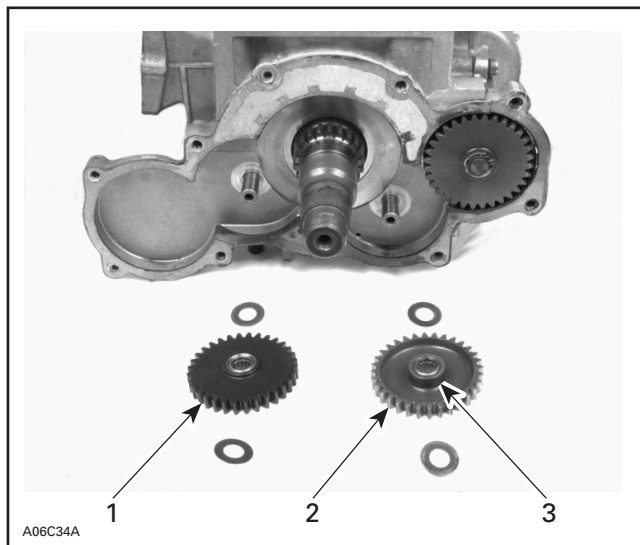

1. Plastic gear
2. Steel gear
3. Shoulder facing crankcase

LEAK TEST AND ENGINE DIMENSION MEASUREMENT

LEAK TEST

The following gives verification procedures for liquid cooled engines though it also applies to fan cooled engines. For FC engines, do not consider information pertaining to coolant system and crankcase rotary valve gear reservoir/components.

On twin-cylinder engines, each cylinder can not be verified individually due to leakage from one cylinder to the other through rotary valve (except on engines with separate intake manifolds). Besides, on FC engines, leak will occur through labyrinth sleeve in center of crankshaft.

On three-cylinder engines, each cylinder can be verified individually.

PREPARATION

1. Remove tuned pipe/muffler and exhaust manifold.
2. Install plug(s) over exhaust flange(s). Tighten with previously removed screws.
3. On engines with RAVE system, remove RAVE valves and install plugs over flanges. Tighten with previously removed screws.
4. Remove carburetor(s).
5. Insert plug(s) in intake rubber boot(s). Tighten with clamps already there.
6. Using a hose pincher(s) (P/N 529 0099 00), block impulse hose(s).

NOTE: Do not block large hoses of rotary valve gear lubrication system.

7. Install air pump on any valve of exhaust plug.

NOTE: If necessary, lubricate air pump piston with mild soap.

8. Rotate crankshaft so that piston goes to B.D.C. (Bottom Dead Center) on side where the pump is installed. This will open exhaust port.
9. Activate pump and pressurize engine to 34 kPa (5 PSI). Do not exceed this pressure.
10. Engine must stand this pressure during 3 minutes. If pressure drops before 3 minutes, check tester kit by spraying a soapy solution on pump piston, all plugs and fittings.
 - If tester kit is leaking, bubbles will indicate where leak comes from.
 - If tester kit is not leaking, check engine as per following procedure.

PROCEDURE

NOTE: A flow chart has been prepared as a visual reference. See last page of this chapter.

Using flow chart and following text, pressurize area to be tested and spray soapy solution at the indicated location.

**TEST PRESSURE: 34kPa (5 PSI)
for 3 minutes**

- If there is a leak at the tested location, it is recommended to continue testing next items before overhauling engine. There is a possibility of more than one leak.
- If there is no leak at the tested location, continue pumping to maintain pressure and continue with next items until leak is found.

▼ CAUTION

Using hydrocarbon lubricant (such as engine oil) will damage rubber seal of pump piston.

Section 03 ENGINE

Sub-Section 03 (LEAK TEST AND ENGINE DIMENSION MEASUREMENT)

Engine

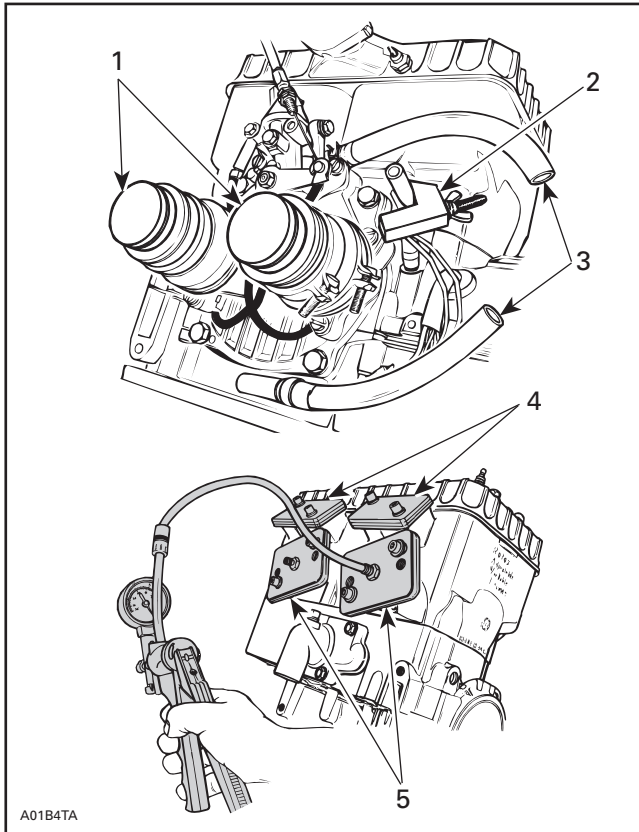

TYPICAL

1. Blocked intake flanges
2. Blocked impulse fitting
3. Open ends (if applicable)
4. Blocked RAVE valve flanges (if applicable)
5. Blocked exhaust flanges

When exhaust manifold is installed, use rubber plug. (In this case it is not necessary to move piston to B.D.C.).

Check the following:

1. All jointed surfaces and screw/stud threads of engine:
 - spark plug base, insulator
 - cylinder head
 - cylinder base
 - crankcase halves (joint)
 - rotary valve cover
 - oil injection pump mounting flange (O-ring, seal)
 - coolant pump housing
 - bleed screws/plugs
2. Small injection oil lines coming from pump.

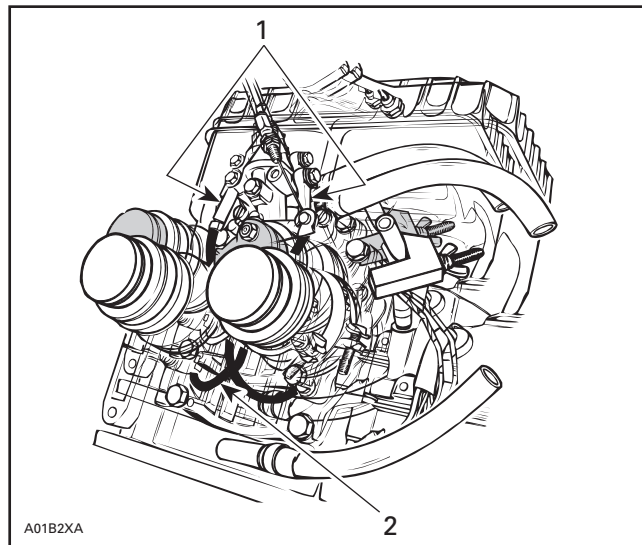

1. Banjo fittings
2. Small injection oil lines

Check for air bubbles or oil column going toward pump. It indicates defective check valve in banjo fitting (or lines).

3. Remove cooling system cap.

Check for air bubbles in antifreeze. It indicates defective cylinder head O-ring or cylinder base gasket.



1. Rubber Plug

- Block both hoses of rotary valve gear lubrication system with hose pinchers.

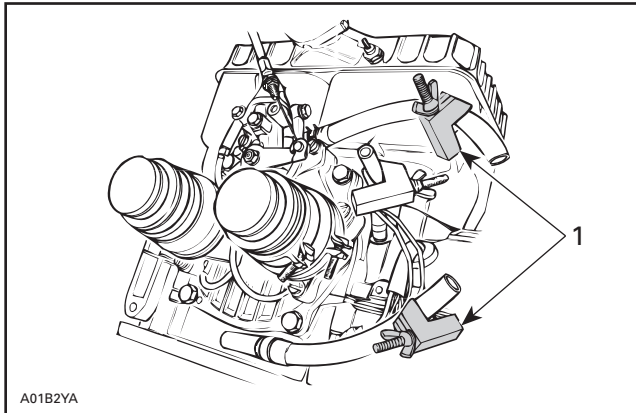

1. *Block both hoses*

If leakage stops, ignore remaining items and check crankcase rotary valve gear reservoir as per **Crankcase Rotary Valve Gear Reservoir** of this section.

- Remove clutch then check crankshaft outer seal.
- Remove rewind starter and magneto system then check crankshaft outer seal.
- Check crankcase rotary valve gear reservoir.

Crankcase Rotary Valve Gear Reservoir

Block one hose of rotary valve gear lubrication system with a hose pincher and install an adapter in remaining hose.

Install air pump on adapter and pressurize as before.

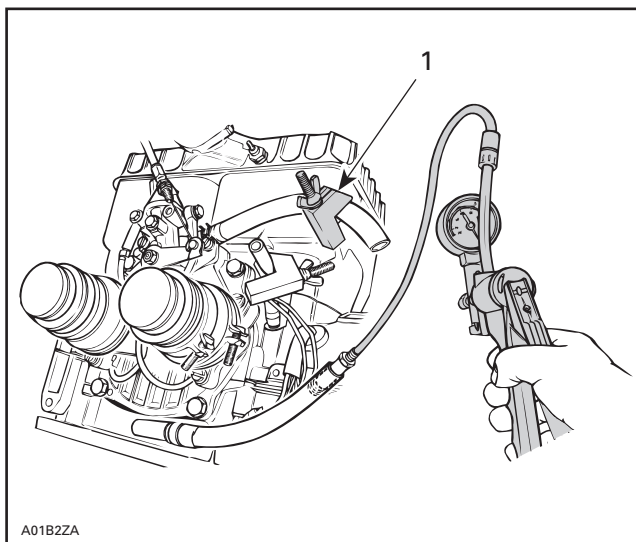

1. *Blocked hose*

- Remove a spark plug or any plug of leak tester kit on PTO side.

If pressure drops, it indicates defective crankshaft inner seal on PTO side.

- Remove a spark plug or any plug of leak tester kit on MAG side.

If pressure drops, it indicates defective crankshaft inner seal on MAG side.

- Check drain hole below coolant pump housing with soapy water.

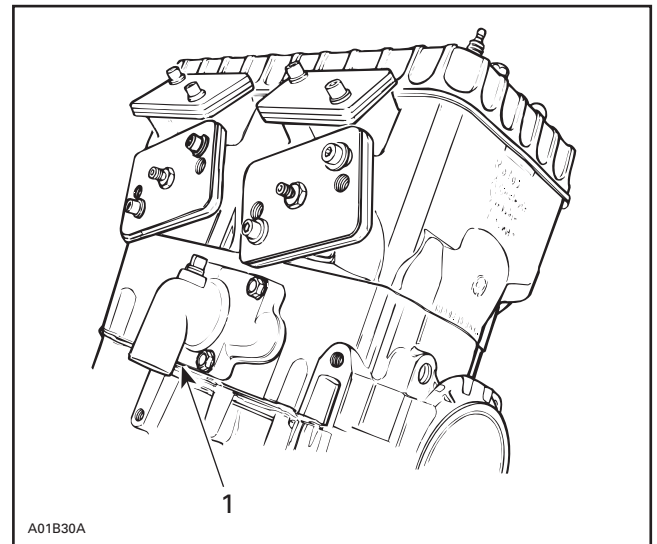

1. *Drain hole*

If there is a leak, it indicates defective seal of rotary valve shaft (oil seal beside coolant seal).

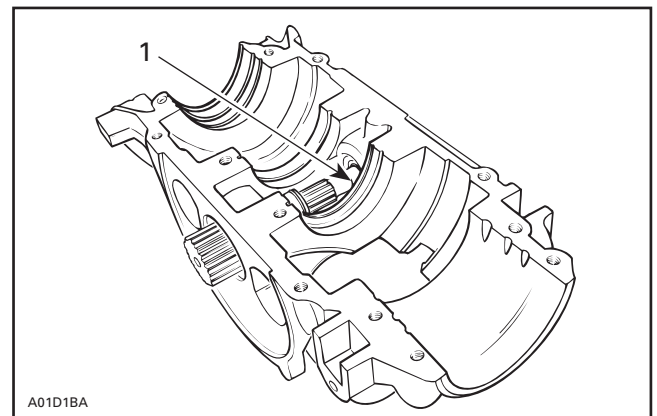

1. *Oil seal*

Section 03 ENGINE

Sub-Section 03 (LEAK TEST AND ENGINE DIMENSION MEASUREMENT)

4. Remove rotary valve cover and check for leak of rotary valve seal with soapy water.

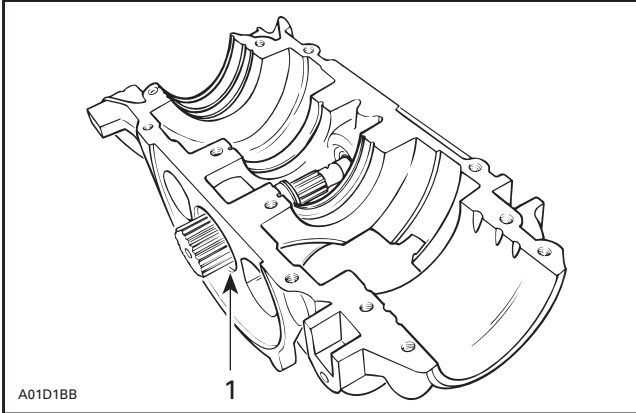

1. Seal

5. If leak still persists, it indicates a defective casting somewhere in engine.

Disassemble engine and carefully check for defects in castings. Pay attention to tapped holes which may go through engine sealed area and thus leading to leakage.

FINALIZING REASSEMBLY

After reassembling engine, always recheck for leakage.

COOLING SYSTEM LEAK TEST

Install special plug (radiator cap) (P/N 529 0214 00) and hose pincher (P/N 529 0099 00) on overflow hose. Pressurize all system through coolant reservoir to 15 PSI.

Check all hoses and cylinder/base for coolant leaks. Spray a soap/water solution and look for presence of air bubbles.

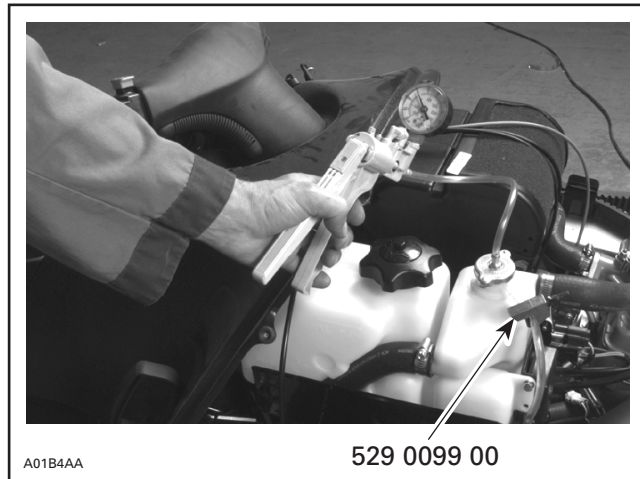

TYPICAL

ENGINE LEAK VERIFICATION FLOW CHART

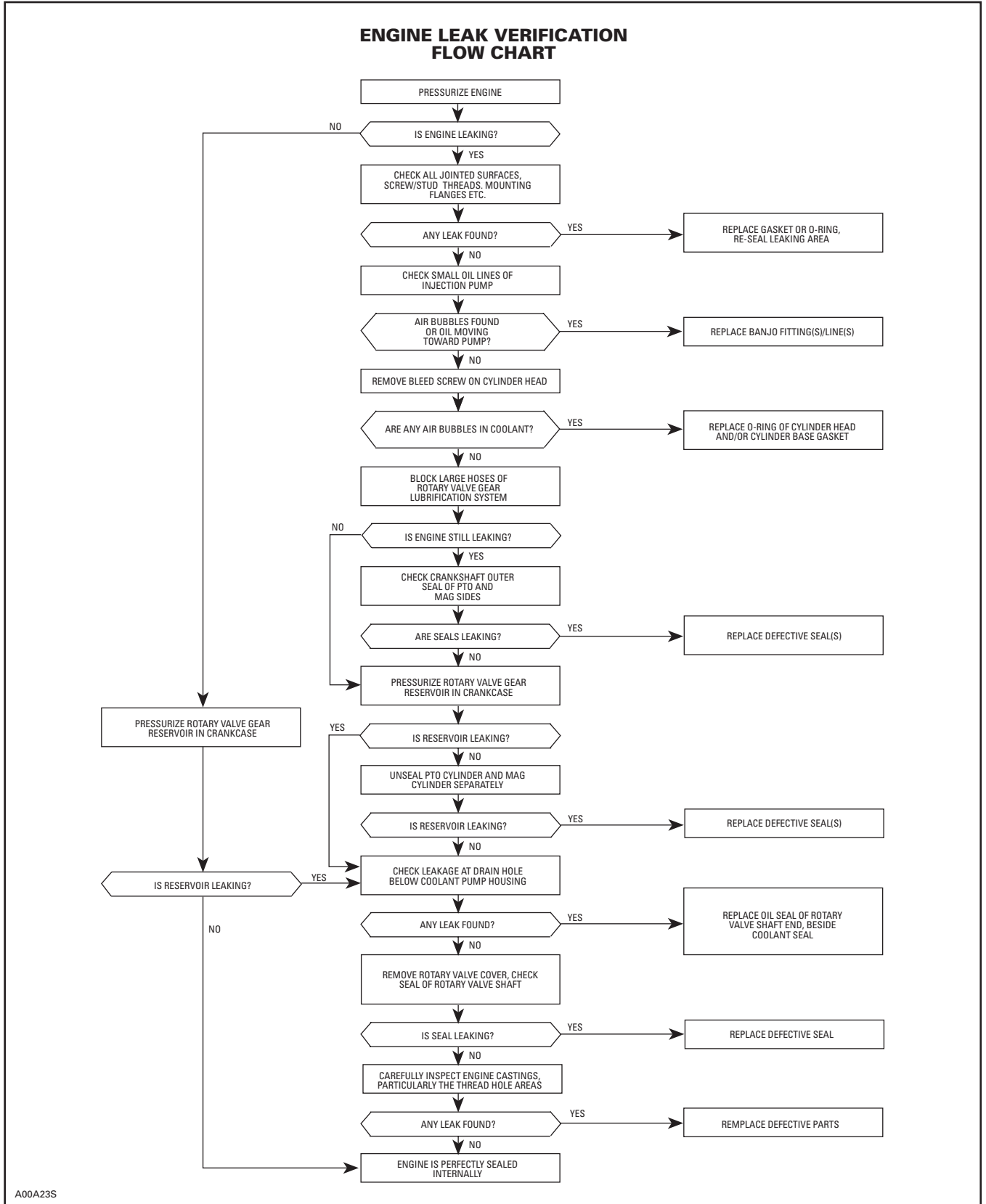

Section 03 ENGINE

Sub-Section 03 (LEAK TEST AND ENGINE DIMENSION MEASUREMENT)

ENGINE DIMENSION MEASUREMENT

This section covers all engine types.

CYLINDER TAPER

ENGINE TYPE	MAXIMUM
All	0.08 mm (.003 in)

Compare cylinder diameter 16 mm (5/8 in) from top of cylinder to just below its intake port area.

On rotary valve engines, measure just below auxiliary transfer port, facing exhaust port. If the difference exceeds the specified dimension the cylinder should be rebored and honed or should be replaced.

NOTE: Be sure to restore the chamfer around all cylinder sleeve port openings.

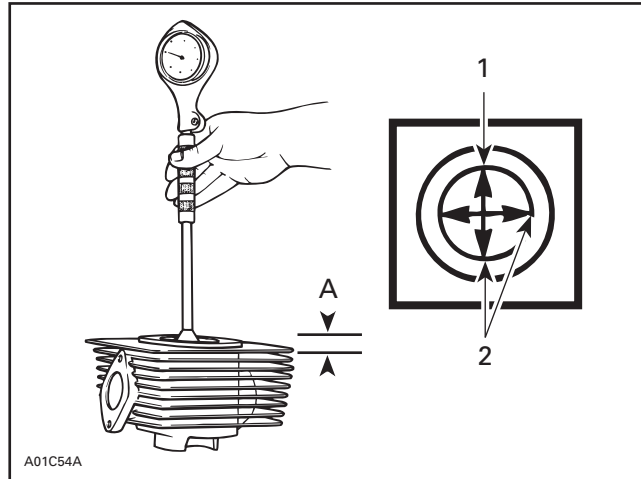

1. Piston pin position
2. Measures to be compared
- A. 16 mm (5/8 in)

CYLINDER/PISTON CLEARANCE

Measurement (used parts)

Check cylinder taper and out-of-round as described above before proceeding with piston/cylinder clearance.

To accurately determine piston to cylinder clearance, the piston should be measured under the axis hole and 90° to piston pin axis. Find the biggest diameter.

The cylinder should be measured 16 mm (5/8 in) below its top edge. Find the smallest diameter.

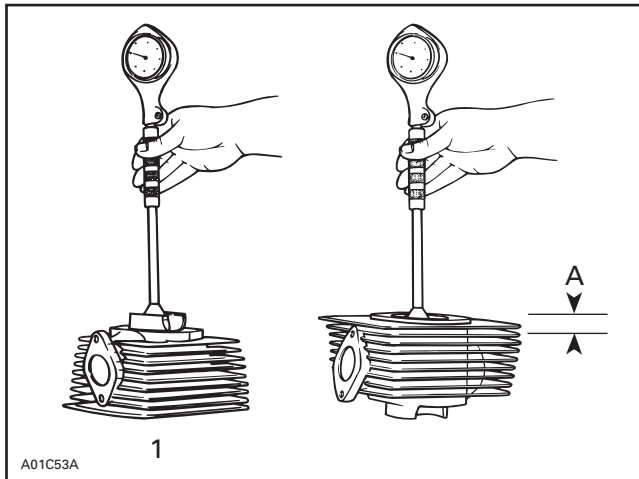

1. Below the intake port
- A. 16 mm (5/8 in) from top

CYLINDER OUT OF ROUND

ENGINE TYPE	MAXIMUM
All	0.05 mm (.002 in)

Measuring 16 mm (5/8 in) from top of cylinder with a cylinder gauge, check if the cylinder out of round is more than the specified dimension. If larger, cylinder should be rebored and honed or should be replaced.

NOTE: Be sure to restore the chamfer around all cylinder sleeve port openings.

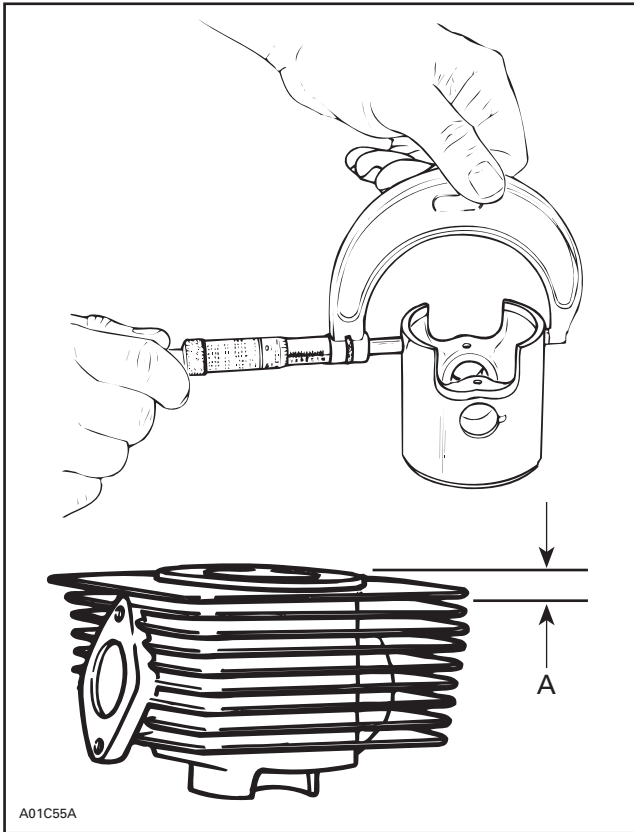

A. 16 mm (5/8 in)

The difference between these 2 measurements should be within specified tolerance. Refer to TECHNICAL DATA 09-02.

Measurement (fitting new parts)

With an inside micrometer, measure cylinder diameter above the exhaust port.

With a micrometer, measure the piston diameter perpendicularly (90°) to piston axis and 3 mm (1/8 in) above bottom edge.

The difference of both measurements is the clearance.

RING/PISTON GROOVE CLEARANCE

Using a feeler gauge check clearance between rectangular ring and groove. Replace piston. If clearance exceeds specified tolerance. Refer to TECHNICAL DATA 09-02.

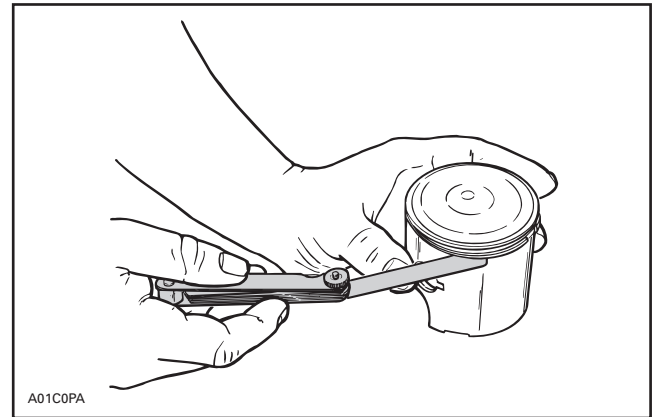

RING END GAP

Position ring half way between transfer ports and intake port. On rotary valve engines, position ring just below transfer ports.

NOTE: In order to correctly position the ring in the cylinder, use piston as a pusher.

Using a feeler gauge, check ring end gap. Replace ring. If gap exceeds specified tolerance, refer to TECHNICAL DATA 09-02.

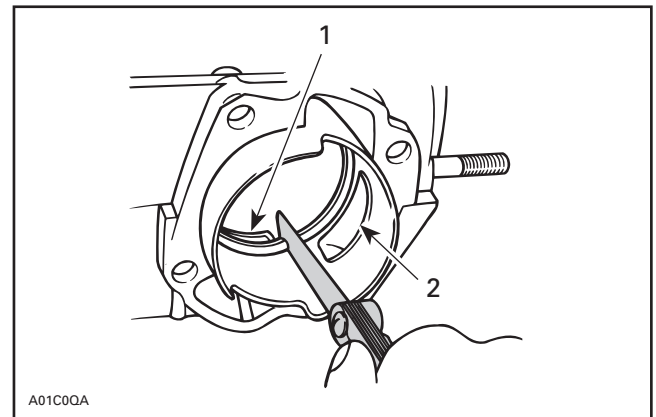

1. Transfer port
2. Intake port

CRANKSHAFT DEFLECTION

Crankshaft deflection is measured with a dial indicator.

Measuring (in engine)

First, check deflection with crankshaft in engine. If deflection exceeds the specified tolerance, re-check deflection using V-shaped blocks to determine the defective part(s). See below.

Section 03 ENGINE

Sub-Section 03 (LEAK TEST AND ENGINE DIMENSION MEASUREMENT)

Measuring (on bench)

Once engine is disassembled, check crankshaft deflection on V-shaped blocks. If deflection exceeds the specified tolerance, it can be worn bearings or a bent crankshaft. Remove crankshaft bearings and check deflection again on V-shaped blocks to determine the defective part(s). See measurement A in following illustration.

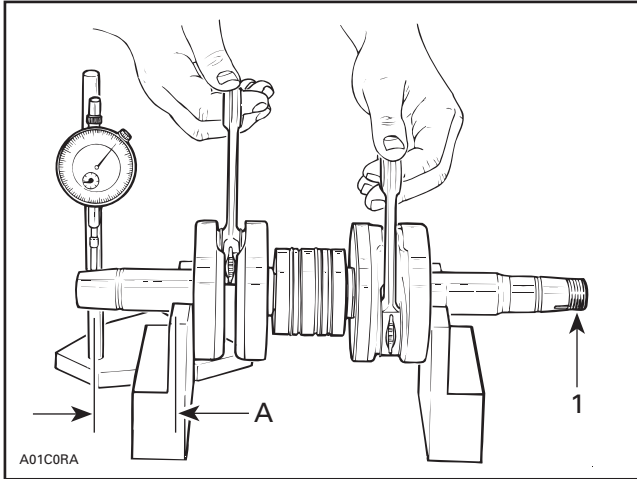

TYPICAL

1. Measure at mid point between the key and the first thread
- A. See table below

Crankshaft Deflection on PTO Side

ENGINE TYPE	DISTANCE A mm (in)	MAXIMUM ON PTO SIDE mm (in)
All	94.5 (3.720)	0.03 (.0012)

Crankshaft Deflection on MAG Side

ENGINE TYPE	MAXIMUM ON MAG SIDE mm (in)
All	0.05 (.002)

Crankshaft Deflection in Center of Crankshaft

ENGINE TYPE	MAXIMUM IN CENTER OF CRANKSHAFT
All	0.08 mm (.0031 in)

NOTE: Crankshaft deflection can not be correctly measured between centers of a lathe.

If the deflection exceeds the specified tolerance, crankshaft should be repaired or replaced.

CONNECTING ROD BIG END AXIAL PLAY

ENGINE TYPE	NEW PARTS MIN. – MAX.	WEAR LIMIT
All	0.40 – 0.75 mm (.016 – .029 in)	1.20 mm (.047 in)

Using a feeler gauge, measure distance between thrust washer and crankshaft counterweight. If the distance exceeds specified tolerance, repair or replace the crankshaft.

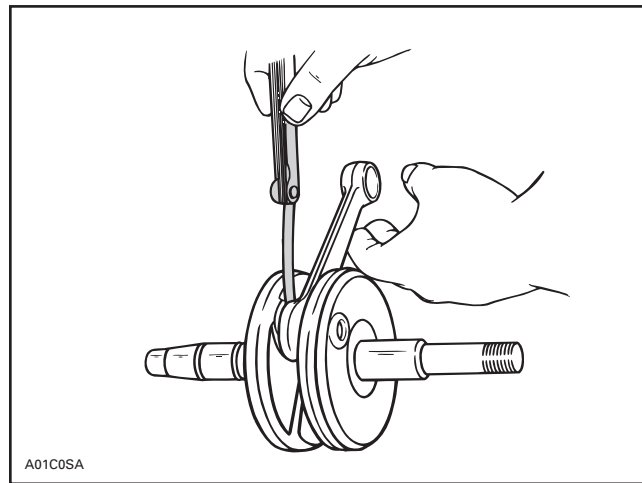

TYPICAL

CONNECTING ROD/PISTON PIN CLEARANCE

Measure piston pin with its needle bearing. Compare to inside diameter of connecting rod.

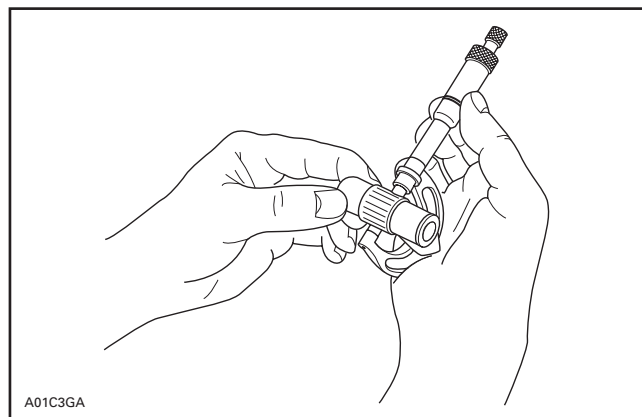

A01C3GA

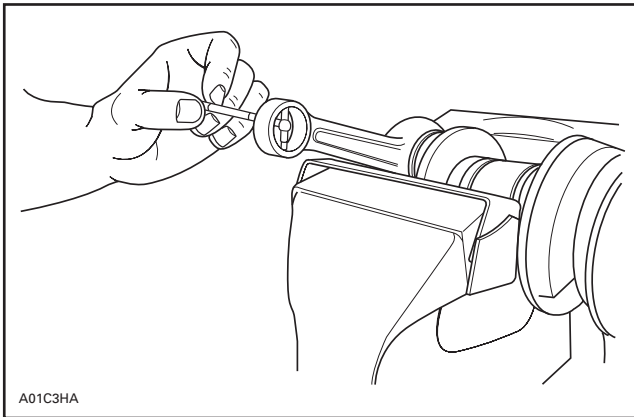

ENGINE TYPE	NEW PARTS MIN. – MAX.	WEAR LIMIT
All	0.03 – 0.012 mm (.0001 – .0005 in)	0.015 mm (.0006 in)

CONNECTING ROD/CRANKPIN CLEARANCE

ENGINE TYPE	NEW PARTS MIN. – MAX.	WEAR LIMIT
599 and 699	0.024 – 0.038 mm (.0009 – .0015 in)	0.06 mm (.0024 in)
809	0.020 – 0.033 mm (.0008 – .0013 in)	

CRANKSHAFT END-PLAY

All Engine Types

End-play is not adjustable but it should be between 0.10 – 0.30 mm (.004 – .012 in).

CHECKING SURFACE FLATNESS

Intake manifold, intake manifold cover, rotary valve cover can be checked for perfectly mating surfaces.

Lay part on a surface plate (marble, mirror or thick glass plate).

Holding down one end of part, try pushing down the other end.

If any play is felt, part must be rectified.

RECTIFYING SURFACES

Stick a fine sand paper sheet on the surface plate then lightly oil the sand paper.

Rub manifold mating surface on sand paper using 8-figure movements.

Sand until mating surface is perfectly straight.

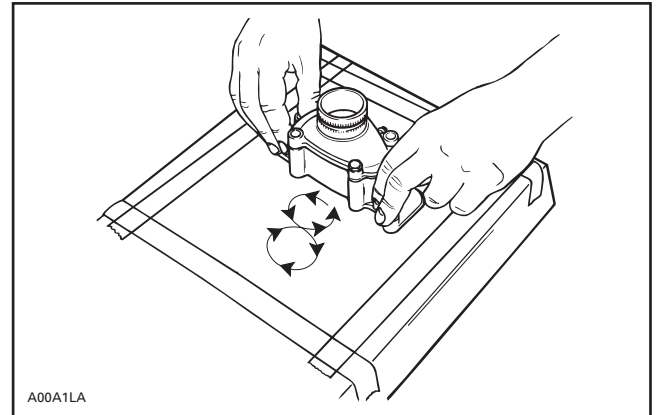

CHECKING CRANKSHAFT ALIGNMENT

Install a degree wheel (P/N 414 3529 00) on crankshaft end.

Remove all spark plugs.

Install a TDC gauge (P/N 414 1047 00) in spark plug hole on MAG side.

Bring MAG piston at top dead center.

Rotate degree wheel (not crankshaft) so that 360° mark aligns with center of crankcase. Scribe a mark on crankcase.

Remove TDC gauge and install it on center cylinder.

Bring center piston to top dead center. Degree will rotate with crankshaft.

Section 03 ENGINE

Sub-Section 03 (LEAK TEST AND ENGINE DIMENSION MEASUREMENT)

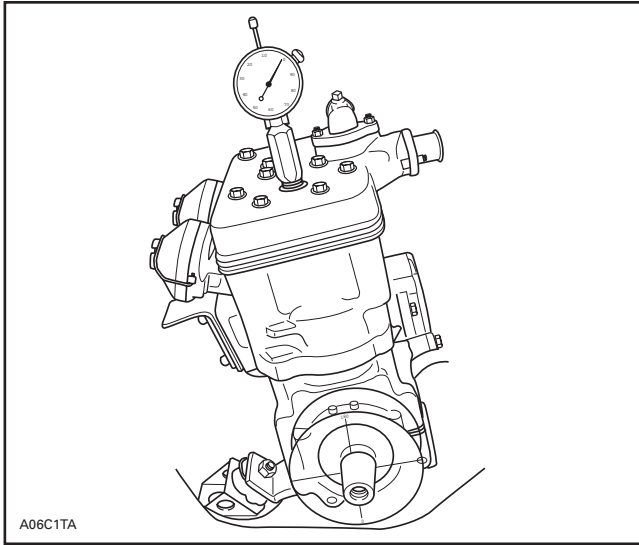

Interval between cylinders must be exactly 120° .
Proceed the same for MAG side piston.
Any other reading indicates a misaligned (twisted) crankshaft.

CDI SYSTEM

NIPPONDENSO TRIGGER COIL IGNITION SYSTEM

599, 699 and 809 Engines

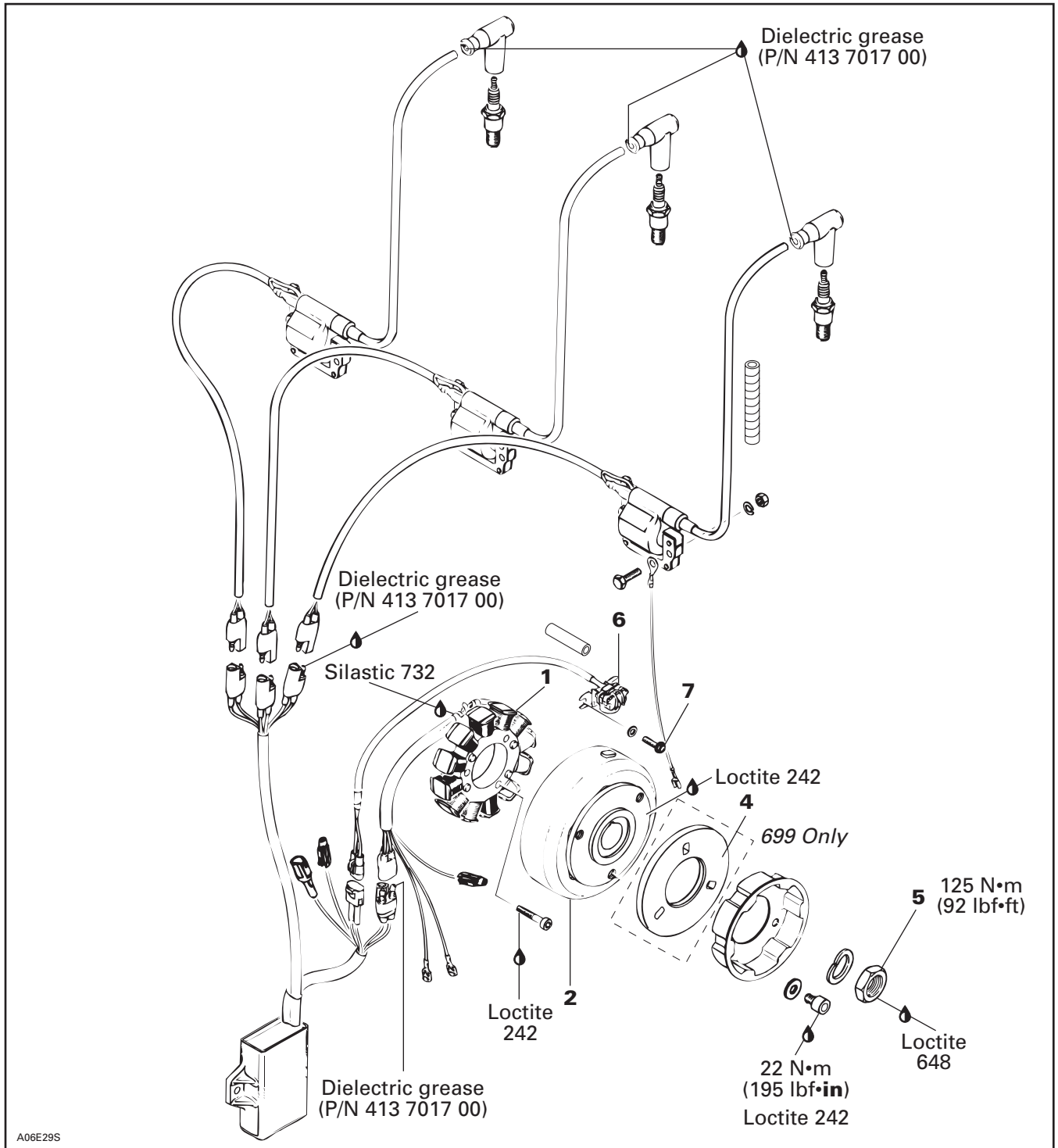

Section 03 ENGINE

Sub-Section 04 (CDI SYSTEM)

NOTE: The following procedures can be done without removing the engine from chassis. To facilitate magneto removal, hold drive pulley with tool (P/N 529 0276 00).

CDI means Capacitor Discharge System.

CLEANING

Clean all metal components in a non-ferrous metal cleaner.



CAUTION

Clean stator and magneto using only a clean cloth.

DISASSEMBLY

2,5, Magneto and Magneto Flywheel Nut

To gain access to magneto assembly, remove the following parts as needed on different engines:

- tuned pipes and muffler
- rewind starter
- starting pulley
- flywheel no. 4 on 699 engine (mark position before removal)

To remove magneto flywheel retaining nut:

Use magneto puller ring (P/N 420 8760 80) modified as shown.

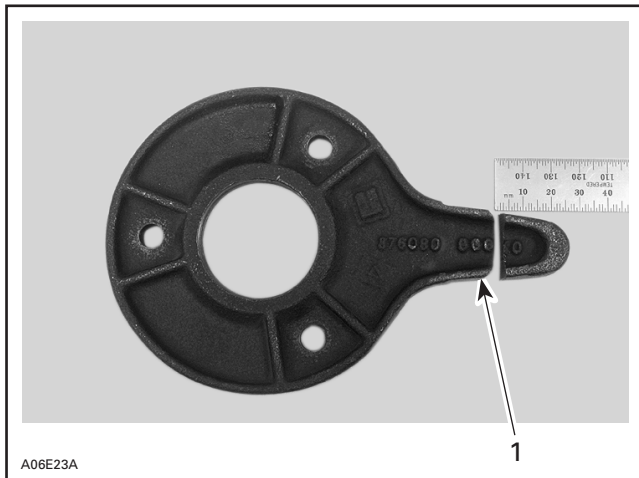

1. Cut by 25 mm (1 in)

Install puller with its tab in magneto housing opening.

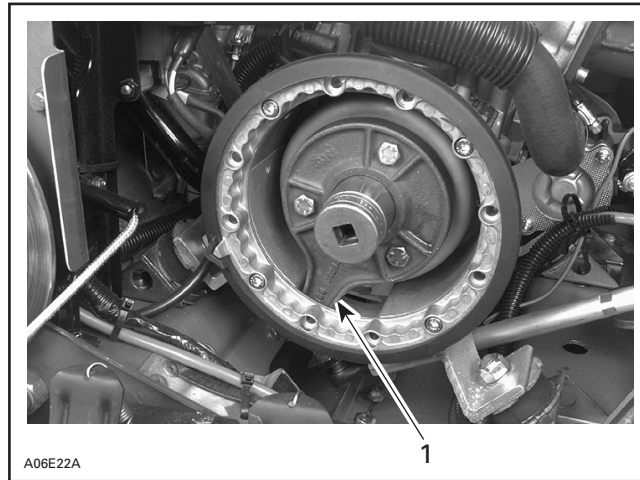

TYPICAL

1. Tab in magneto housing opening

- Remove magneto flywheel nut, using a 30 mm socket machined to 40 mm (1.580 in) outside diameter by 16 mm (5/8 in) long.

NOTE: To correctly remove a threadlocked fastener it is first necessary to tap on the fastener to break threadlocker bond. This will eliminate the possibility of thread breakage.

To remove magneto flywheel, install the puller (P/N 529 0225 00).

- Tighten puller bolt and at the same time, tap on bolt head using a hammer to release magneto flywheel from its taper.

6,7, Trigger Coil and Screw

Magneto and stator plate must be removed before trigger coil removal.

To replace trigger coil:

- Disconnect trigger coil connector housing.
- Remove grommet from crankcase where trigger coil wire exits magneto housing.
- Remove retaining screws.
- Remove trigger coil and carefully pull wires.
- Thread magneto harness through crankcase hole before trigger coil harness.

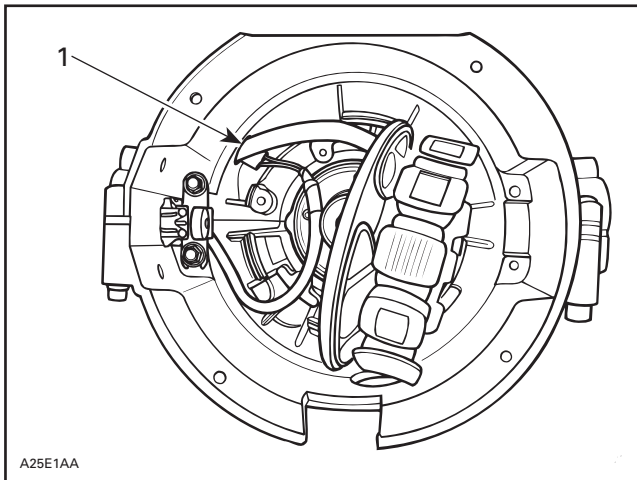

1. Magneto harness through crankcase hole

- Install new trigger coil and other parts removed.

Adjustment

Whenever the trigger coil or the magneto flywheel is removed or replaced, the air-gap between the trigger coil and the flywheel protrusion must be checked and adjusted. The purpose of this adjustment is to obtain the minimum clearance between these parts — without touching at any RPM — so that the trigger coil produces its proper electrical output. Ignition timing must also be checked. Refer to IGNITION TIMING 05-03 then look for **Checking Ignition Timing**.

 CAUTION
Each time trigger coil air-gap is adjusted, ignition timing must be checked.

Proceed as follows:

1. Rotate flywheel so that the protrusion aligns with trigger coil.
2. Using a feeler gauge of 0.75 mm (.030 in) min. 0.55 mm (.022 in) and max. 1.45 mm (.057 in) thick, check air-gap between center pole of trigger coil and flywheel protrusion.
3. If necessary, adjust by slackening retaining screws and moving trigger coil toward or away of protrusion.
4. Retighten screws and recheck air-gap.

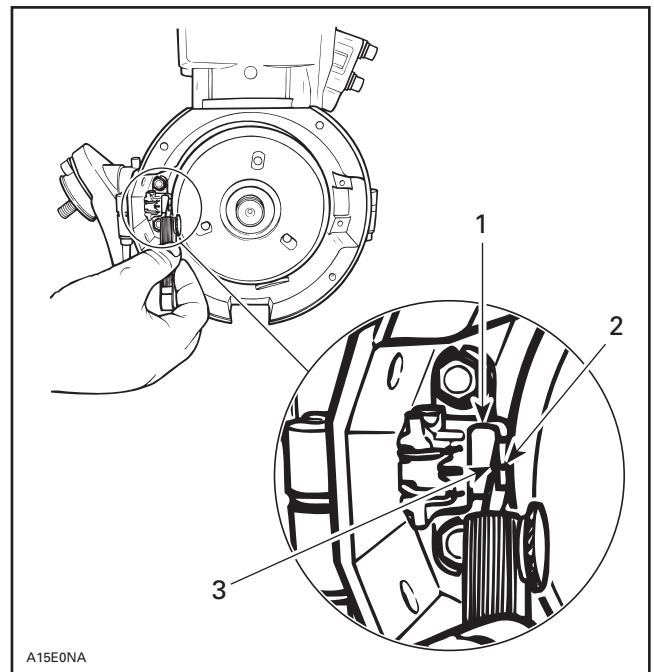

ADJUSTING TRIGGER COIL AIR-GAP

1. Trigger coil
2. Flywheel protrusion
3. Measure at center pole of trigger coil 0.75 mm (.030 in)

1, Stator

To replace stator:

- Disconnect the 3-wire connector (BLACK, RED and BLACK/RED wires).
- Disconnect both YELLOW wires.
- Remove grommet from crankcase where magneto harness exits magneto housing.
- Remove stator plate retaining screws.
- Remove stator plate with stator and carefully pull wires.
- Install new parts and other parts removed taking care not to squeeze trigger coil harness.

Section 03 ENGINE

Sub-Section 04 (CDI SYSTEM)

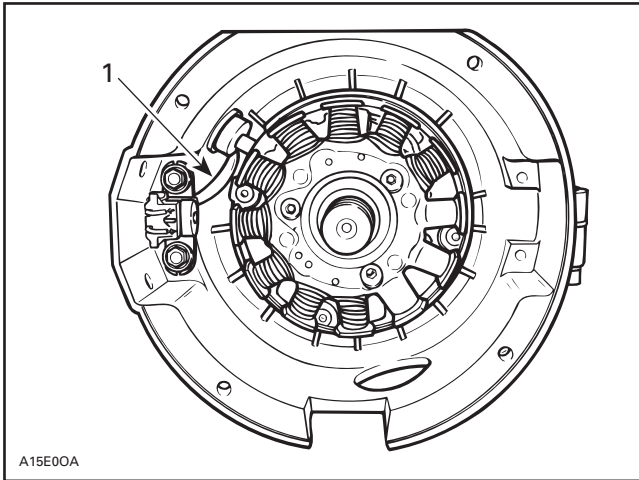

1. Trigger coil harness

ASSEMBLY

3, Oil Seal

Use pusher (P/N 420 8765 14) to install oil seal into stator.

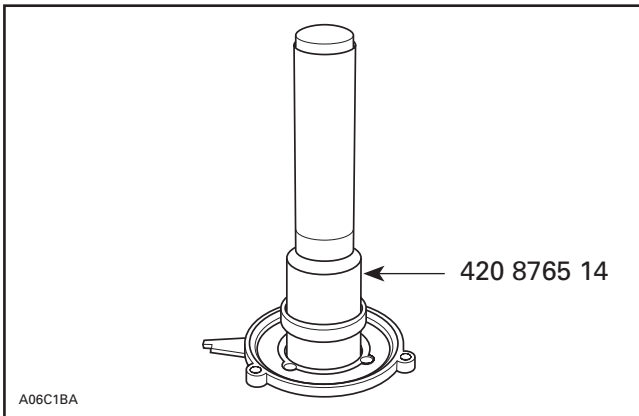

2,5, Magneto Flywheel and Nut

Clean crankshaft extension (taper) and apply Loctite 242 (blue) on taper, then position Woodruff key, flywheel and lock washer on crankshaft.

Clean nut threads and apply Loctite 242 (blue) then tighten nut 125 N•m (92 lbf•ft).

At reassembly coat all electric connections with silicone dielectric grease (P/N 413 7017 00) to prevent corrosion or moisture penetration.



CAUTION

Do not use silicone "sealant", this product will corrode contacts.

Ignition Timing

Check as described in IGNITION TIMING 05-03.

OIL INJECTION SYSTEM

OIL INJECTION PUMP

599, 699 and 809 Engines

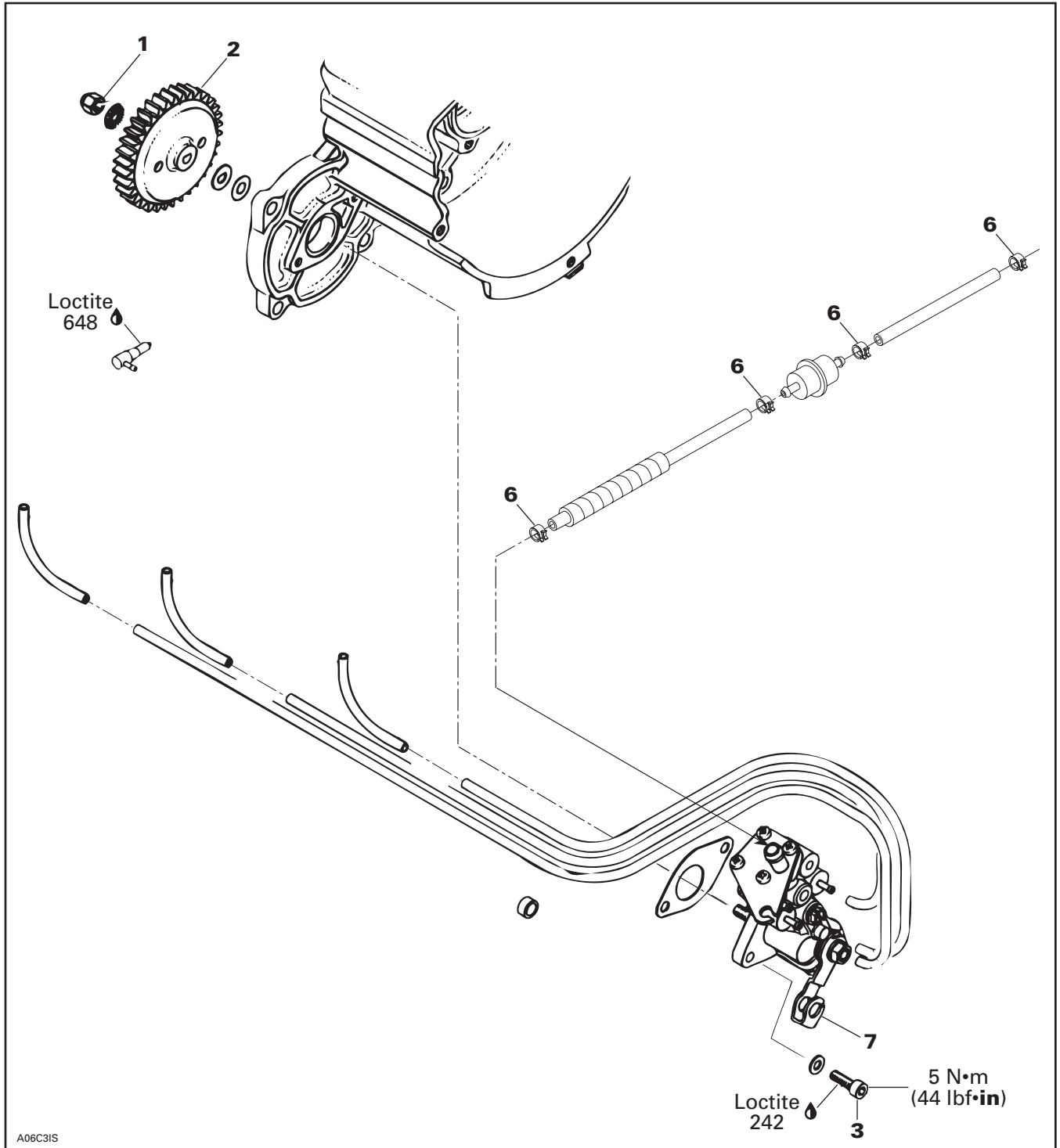

A06C31S

Section 03 ENGINE

Sub-Section 05 (OIL INJECTION SYSTEM)

OIL PUMP IDENTIFICATION

7, Pump Lever

Different engines need different pumps. Oil pumps are identified by their levers.



CAUTION

Always mount proper pump on engine.

ENGINE TYPE	OIL PUMP IDENTIFICATION
599	04
699	07
809	03

NOTE: The following procedures can be done without removing the engine from chassis.

CLEANING

Clean all metal components in a non-ferrous metal cleaner.

DISASSEMBLY

NOTE: Some oil pump components are not available as single parts.

1,2, Gear Retaining Nut and Oil Pump Gear

To remove gear retaining nut, first extract the needle roller with pliers then lock gear in place using one of the following gear holder.

ENGINE TYPE	TOOL P/N
599/699/809	420 2779 05

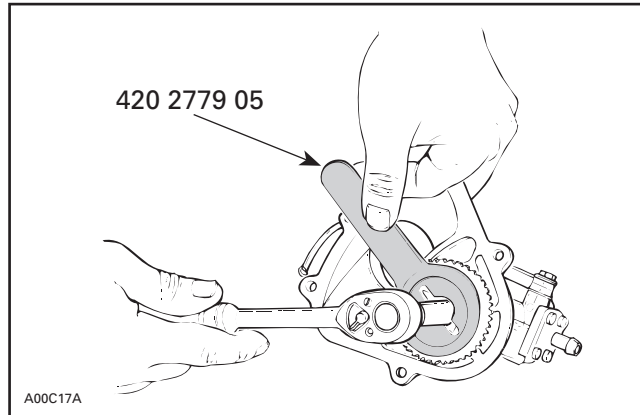

TYPICAL

ASSEMBLY

2, Oil Pump Gear

At gear assembly, apply a light coat of low temperature grease (P/N 413 7061 00) on gear teeth.

5,6, Spring Clip and Clamp

Always check for spring clips tightness.

3, Screw

Torque to 5 N•m (44 lbf•in).

Make sure cable barrel is well seated in oil pump lever.

Secure barrel with plastic washer and circlip.

Verify cable and oil pump lever operation.

ADJUSTMENT

Prior to adjusting the pump, make sure all carburetor adjustments are completed.

Synchronizing Pump with Carburetor:

Eliminate the throttle cable free-play by pressing the throttle lever until a light resistance is felt, then hold in place. The aligning marks on the pump casting and on the lever must align. If not, loosen the adjuster nut and adjust accordingly.

Retighten the adjuster nut.

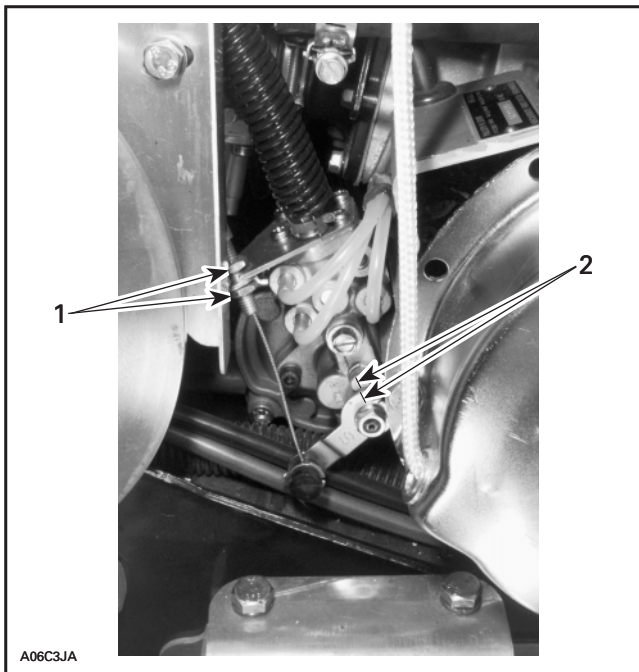

- 1. Adjuster nut
- 2. Marks in line

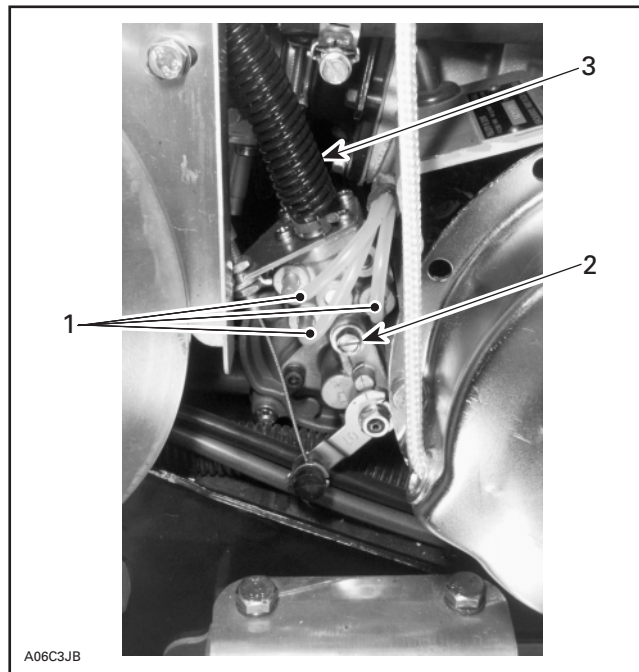

- 1. Small oil lines
- 2. Bleeder screw
- 3. Main oil line

▼ CAUTION

Proper oil injection pump adjustment is very important. Any delay in the opening of the pump can result in serious engine damage.

To Bleed Oil Lines

Bleed main oil line (between tank and pump) by loosening the bleeder screw until air has escaped from the line. Add injection oil as required.

Reinstall all parts.

Bleed the small oil line between pump and intake manifold by running engine at idle while holding the pump lever in fully open position.

NOTE: Make a J hook out of mechanical wire to lift the lever.

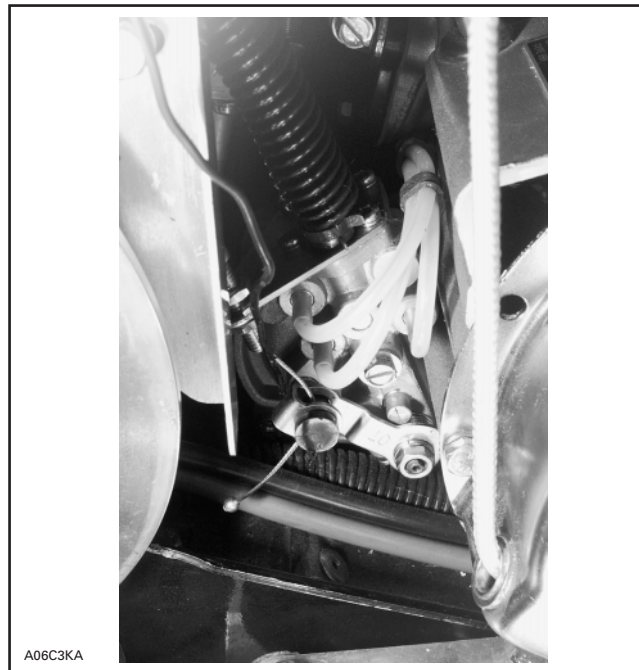

TYPICAL — ENGINE AT IDLE

Section 03 ENGINE

Sub-Section 05 (OIL INJECTION SYSTEM)

◆ WARNING

Ensure not to operate carburetor throttle mechanism. Secure the rear of the vehicle on a stand.

CHECKING OPERATION

On Vehicle

NOTE: Main oil line must be full of oil. See bleeding procedure above.

Lift rear of vehicle and support with a mechanical stand. Unplug oil lines from pump. Start engine and stop it as soon as it fires.

Check that oil in small oil lines has been sucked up (this will be indicated by a clear section of small oil lines). Repeat the procedure until this condition is attained.

Reconnect small oil lines, start engine and run at idle while holding the pump lever in fully open position. Oil columns must advance into small oil lines.

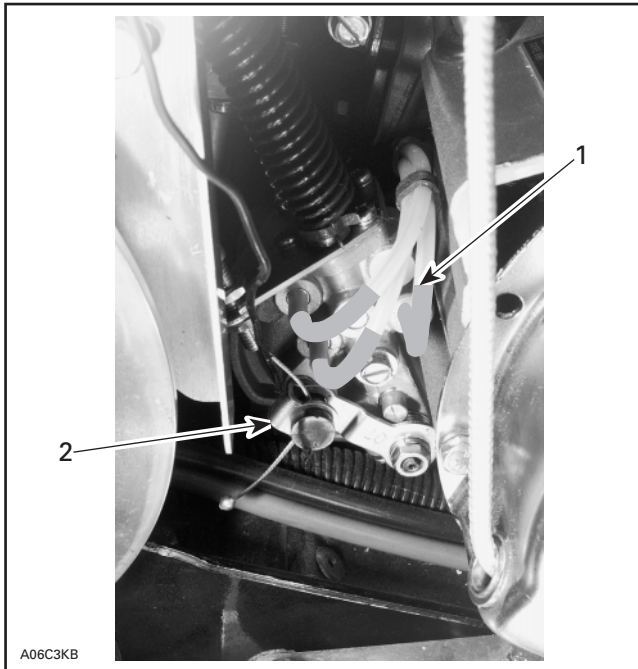

TYPICAL — ENGINE AT IDLE

1. Oil columns advancing
2. Fully open position

If not, remove pump assembly and check the pump gear and drive shaft (if applicable) for defects, replace as necessary. Test pump as describes below.

NOTE: Through normal use, oil level must not drop in small tubes. If oil drops, verify check valve operation in injection nozzle. Replace as necessary.

Oil Pump Test Bench

Connect a hose filled with injection oil to main line fitting. Insert other hose end in an injection oil container. Using a clockwise rotating drill rotate pump shaft. Oil must drip from outer fittings while holding lever in a fully open position. If not replace pump.

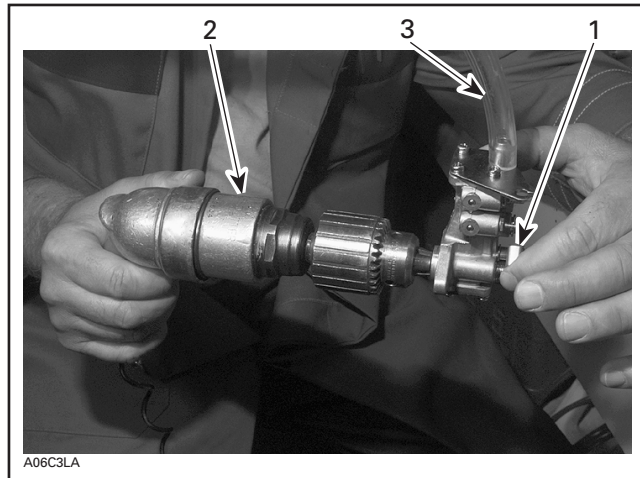

TYPICAL

1. Fully open position
2. Clockwise rotating drill
3. Main line

LIQUID COOLING SYSTEM

599, 699 and 809 Engines

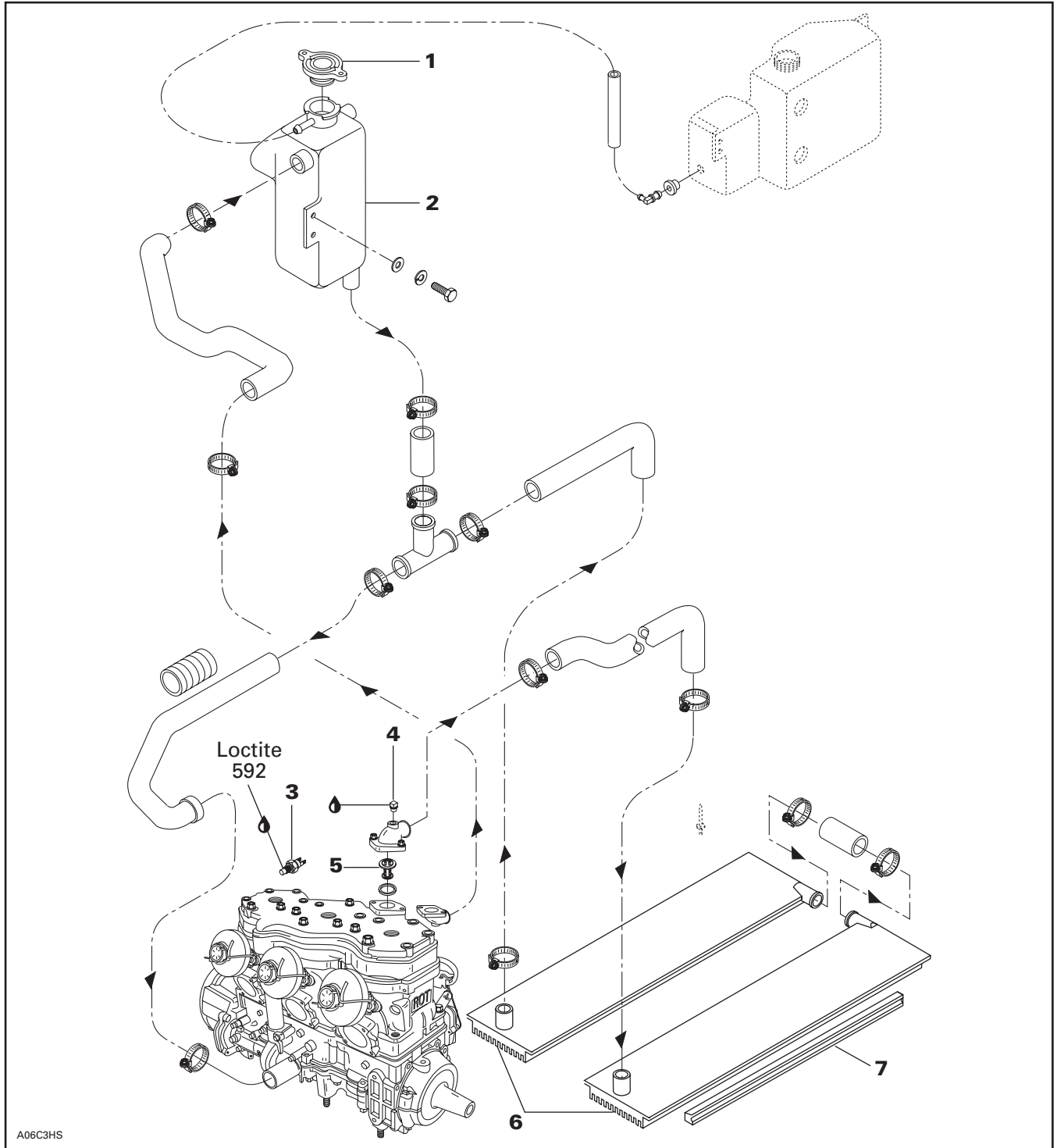

Section 03 ENGINE

Sub-Section 06 (LIQUID COOLING SYSTEM)

INSPECTION

Check general condition of hoses and clamp tightness.

DRAINING THE SYSTEM

◆ WARNING

Never drain or refill the cooling system when engine is hot.

To drain the cooling system, siphon the coolant mixture from the coolant tank. Use a primer pump with a plastic hose inserted as deep as possible into the lower hose.

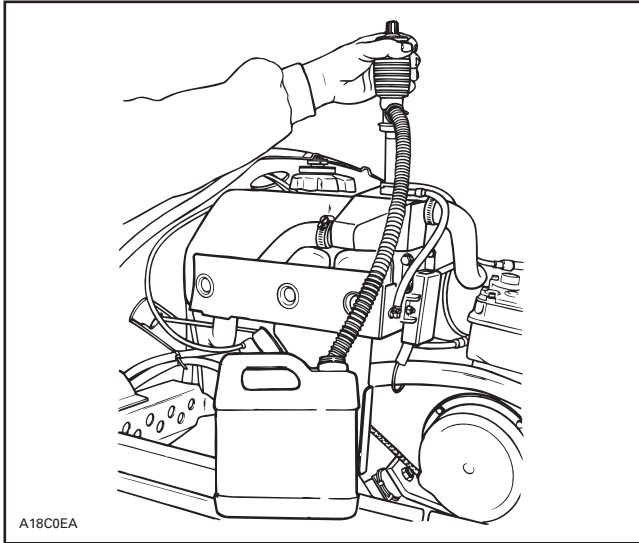

When the coolant level is low enough, lift the rear of vehicle to drain the radiators.

DISASSEMBLY AND ASSEMBLY

3,4, Sender and Plug

Apply thread sealant on sender and plug to avoid leaks.

1, Pressure Cap

Check if the cap pressurizes the system. If not, install a new 90 kPa (13 PSI) cap, (do not exceed this pressure).

6,7, Radiator and Radiator Protector

Insert radiator protector into radiator C-rail and crimp C-rail at both ends. Refer to FRAME 08-02 for radiator removal.

5, Thermostat

To check thermostat, put in water and heat water. Thermostat should open when water temperature reaches the following degree.

ENGINE	TEMPERATURE
All	42°C (108°F)

The thermostat is a double action type.

- Its function is to give faster warm up of the engine by controlling a circuit; water pump — engine — coolant tank. This is done by bypassing the radiator circuit.

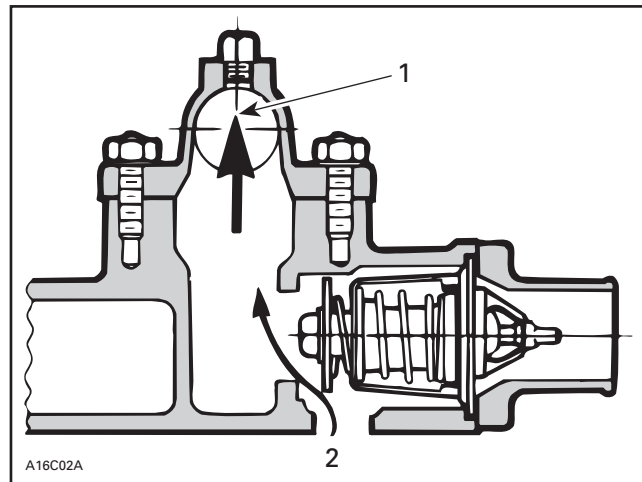

CLOSED THERMOSTAT AND COLD ENGINE

- To reservoir
- From cylinders

- When the liquid is warmed enough, the thermostat opens the circuit, water pump — engine — radiators coolant tank to keep the liquid at the desired temperature. (See the diagram of the exploded view).

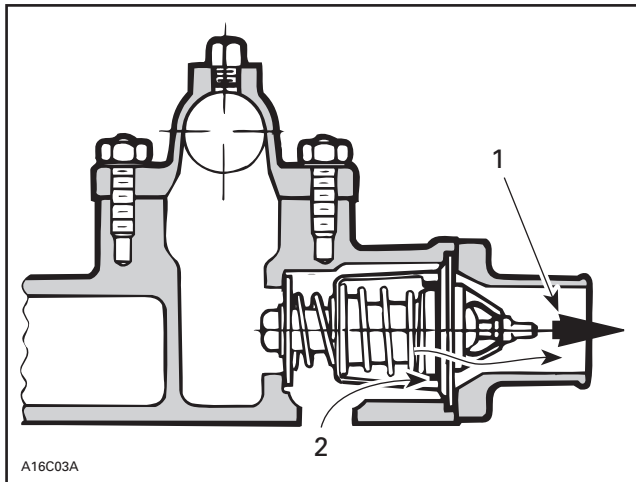

OPEN THERMOSTAT AND WARM ENGINE

1. To radiators
2. From cylinders

These 2 functions have the advantage of preventing a massive entry of cold water into the engine.

2, Coolant Tank

The coolant expands as the temperature (up to 90–100°C (195–212°F)) and pressure rise in the system. When the limiting system working pressure (cap) is reached (90 kPa (13 PSI)), the pressure relief valve in the pressure cap is lifted from its seat and allows coolant to flow through the overflow hose into the overflow coolant tank.

When the system temperature drops, the coolant contracts in volume and the pressure in the coolant tank is reduced. The coolant in the overflow coolant tank will then flow back into the coolant tank through the vacuum relief valve in the pressure cap.

COOLING SYSTEM REFILLING PROCEDURE

Recommended Coolant

Use a blend of 60% antifreeze with 40% water. Do not reinstall pressure cap.

▼ CAUTION

To prevent rust formation or freezing condition, always replenish the system with 60% antifreeze and 40% water. Pure antifreeze without water freezes. Always use ethyl-glycol antifreeze containing corrosion inhibitors specifically recommended for aluminum engines.

System Capacity

Refer to TECHNICAL DATA 09.

Refilling Procedure

With vehicle on a flat surface, engine cold, refill coolant tank up to cold level mark. Wait a few minutes then refill to mark. Install pressure cap. Run engine until thermostat opens then stop engine. Refill up to mark.

To make sure coolant flows through radiators, touch them by hand. They must feel warm.

Reinstall pressure cap.

When engine has completely cooled down, recheck coolant level in coolant tank and top up if necessary.

Check coolant concentration (freezing point) with proper tester.

REWIND STARTER

All Models

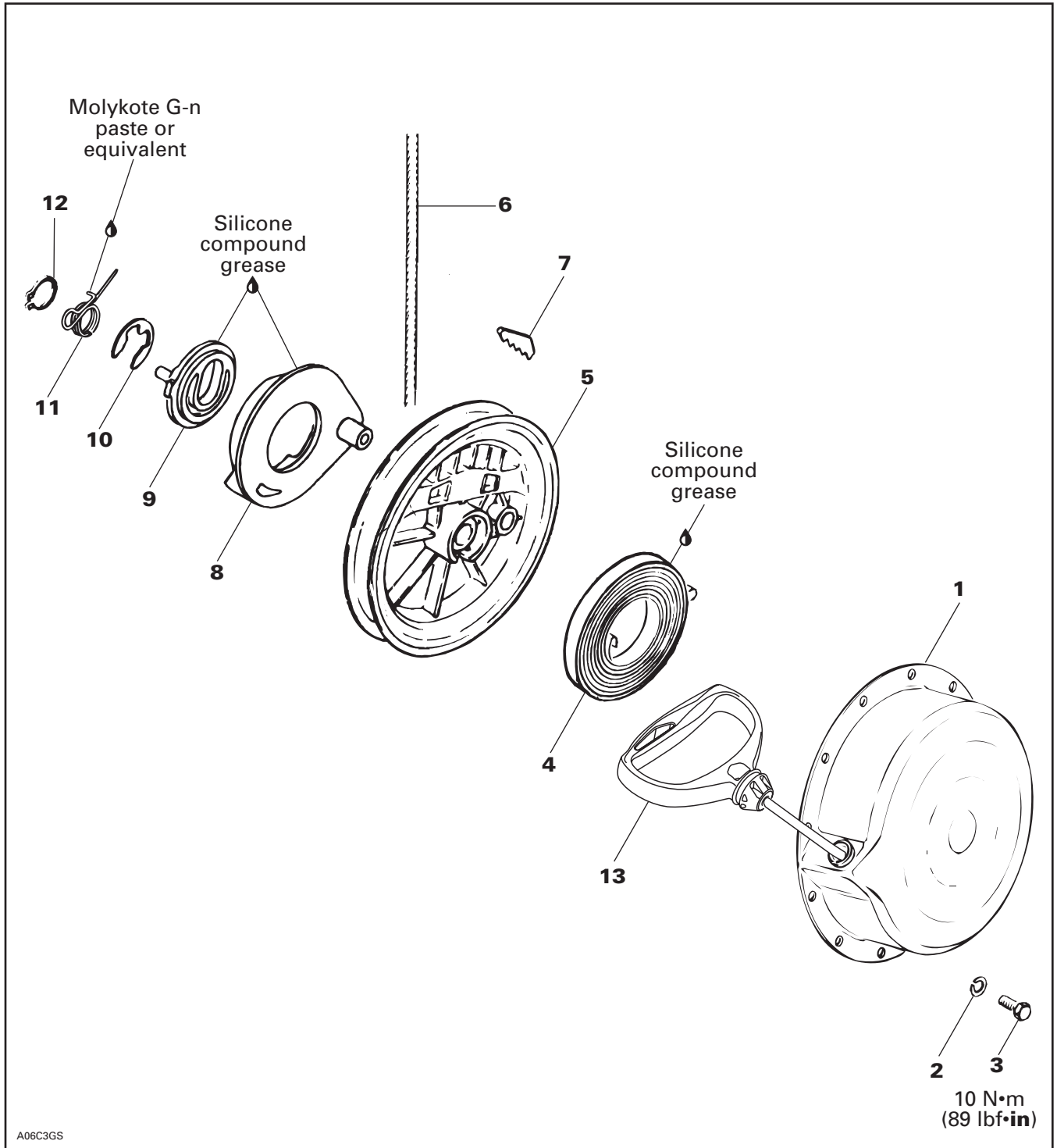

Section 03 ENGINE

Sub-Section 07 (REWIND STARTER)

REMOVAL

Using a small screwdriver, extract rope knot from starter grip **no. 13**. Cut rope close to knot. Tie a knot near starter.

Remove screws **no. 3** and washers **no. 2** securing rewind starter **no. 1** to engine then remove rewind starter.

DISASSEMBLY

To remove rope from rewind starter mechanism:

- First remove locking ring **no. 12**, locking spring **no. 11**, circlip **no. 10**, pawl lock **no. 9** and pawl **no. 8**.
- Remove sheave **no. 5** from starter housing **no. 1**.
- Disengage key **no. 7** and pull out rope **no. 6**.

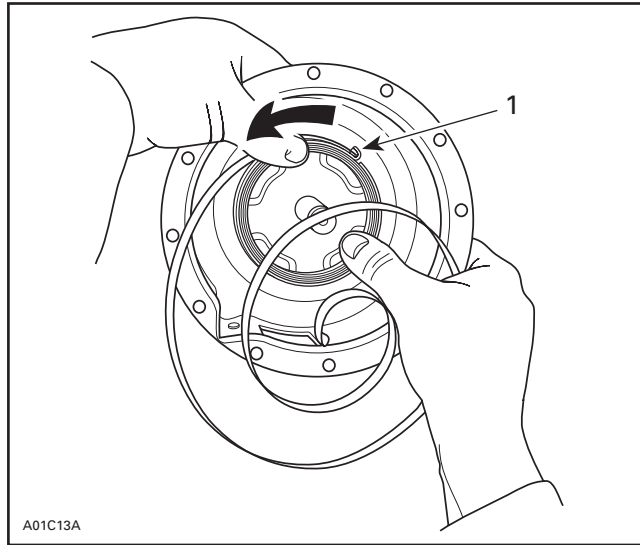

1. Outer end into guide notch

NOTE: Due to dust accumulation, rewind starter must be periodically cleaned, inspected and relubricated.

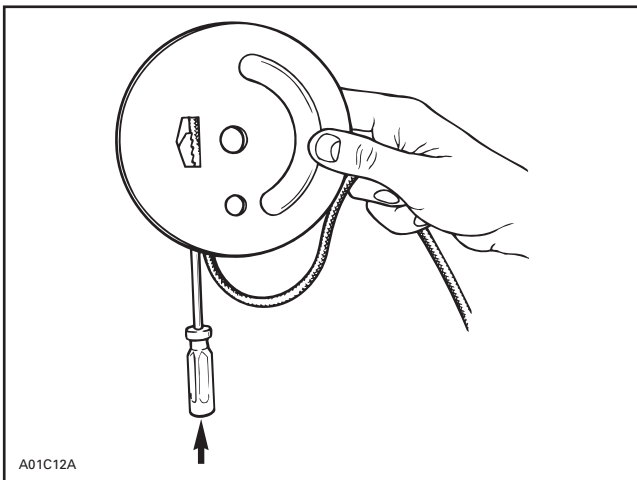

GENTLY TAP ON KEY

ASSEMBLY

At assembly, position spring **no. 4** outer end into spring guide notch then wind the spring counter-clockwise into guide.

◆ WARNING

Since the spring is tightly wound inside the guide it may fly out when rewind is handled. Always handle with care.

▼ CAUTION

It is of the utmost importance that the rewind starter spring(s) be lubricated periodically using specific lubricants. Otherwise, rewind starter component life will be shortened and/or rewind starter will not operate properly under very cold temperatures.

Lubricate spring assembly with silicone compound grease (P/N 420 8970 61) and position into starter housing as illustrated.

▼ CAUTION

This lubricant must NOT be used on rewind starter locking spring as it does not stay on under vibration.

Section 03 ENGINE
Sub-Section 07 (REWIND STARTER)

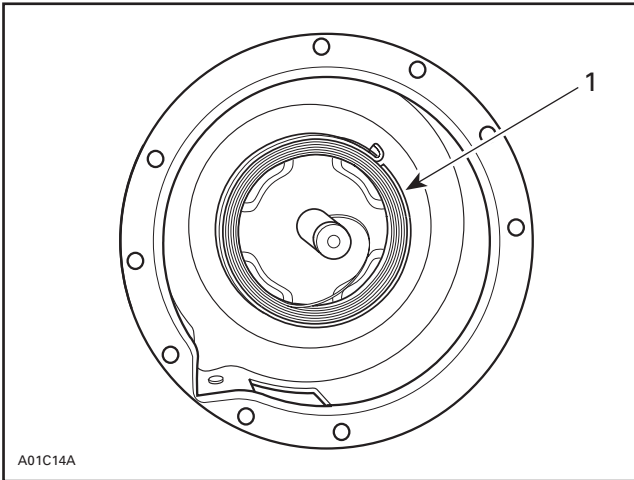

1. Grease inside spring guide

▼ CAUTION

The use of standard multi-purpose grease could result in rewind starter malfunction.

To install a new rope no. 6: insert rope into sheave no. 5 orifice and lock it with the key no. 7 as illustrated.

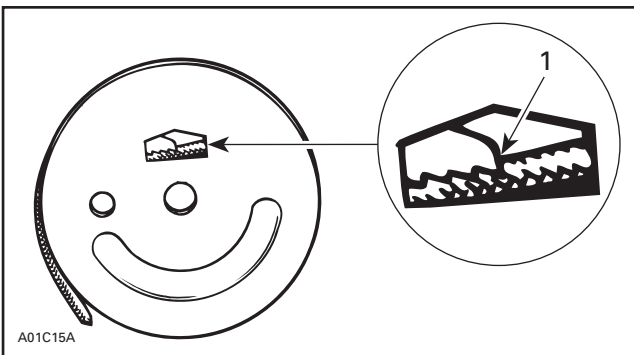

1. Push to lock

To adjust rope tension:

Wind rope on sheave and place rope sheave into starter housing making sure that the sheave hub notch engages in the rewind spring hook.

Rotate the sheave counterclockwise until rope end is accessible through starter housing orifice.

Pull the rope out of the starter housing and temporarily make a knot to hold it. One turn preload will give 7 turns of tension when fully extended.

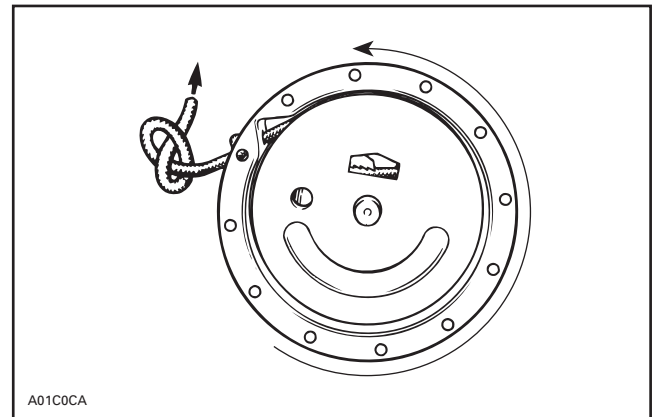

Position pawl no. 8, pawl lock no. 9 and circlip no. 10.

Install locking spring no. 11 and lubricate with MOLYKOTE G-n paste from Dow Corning® or equivalent.

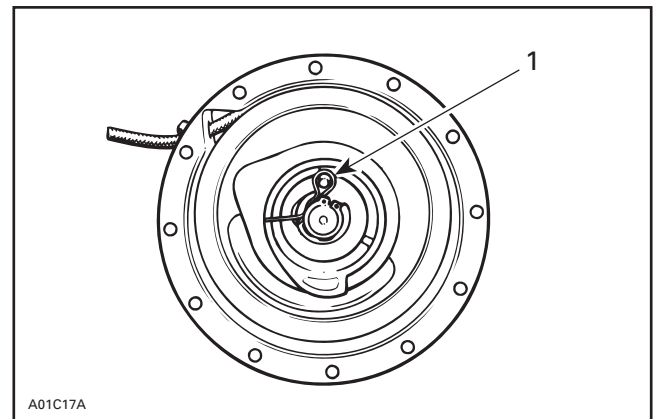

1. Spring coated with MOLYKOTE G-n paste

Install locking ring.

▼ CAUTION

This lubricant must NOT be used on rewind springs as it does not stay on when dry.

Section 03 ENGINE

Sub-Section 07 (REWIND STARTER)

INSTALLATION

On fan cooled models with oil injection pump, re-install oil pump on rewind starter assembly.

Thread starter rope **no. 6** through rope guide when applicable.

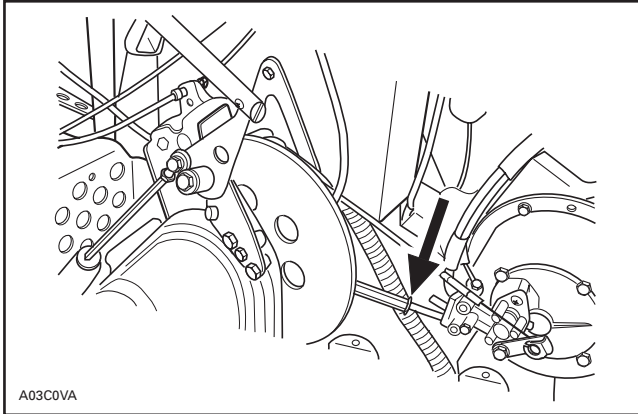

Reinstall rewind starter assembly on engine.

Prior to installing starter grip **no. 13** on new rope, it is first necessary to fuse the rope end with a lit match. Pass rope through starter grip and tie a knot in the rope end. Fuse the knot with a lit match then insert rope end down and pull the starter grip over the knot.

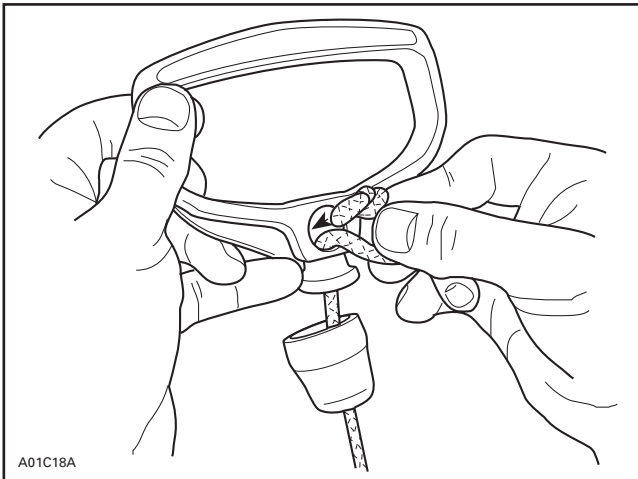

TYPICAL

CARBURETOR AND FUEL PUMP

Formula III/III LT and Mach 1

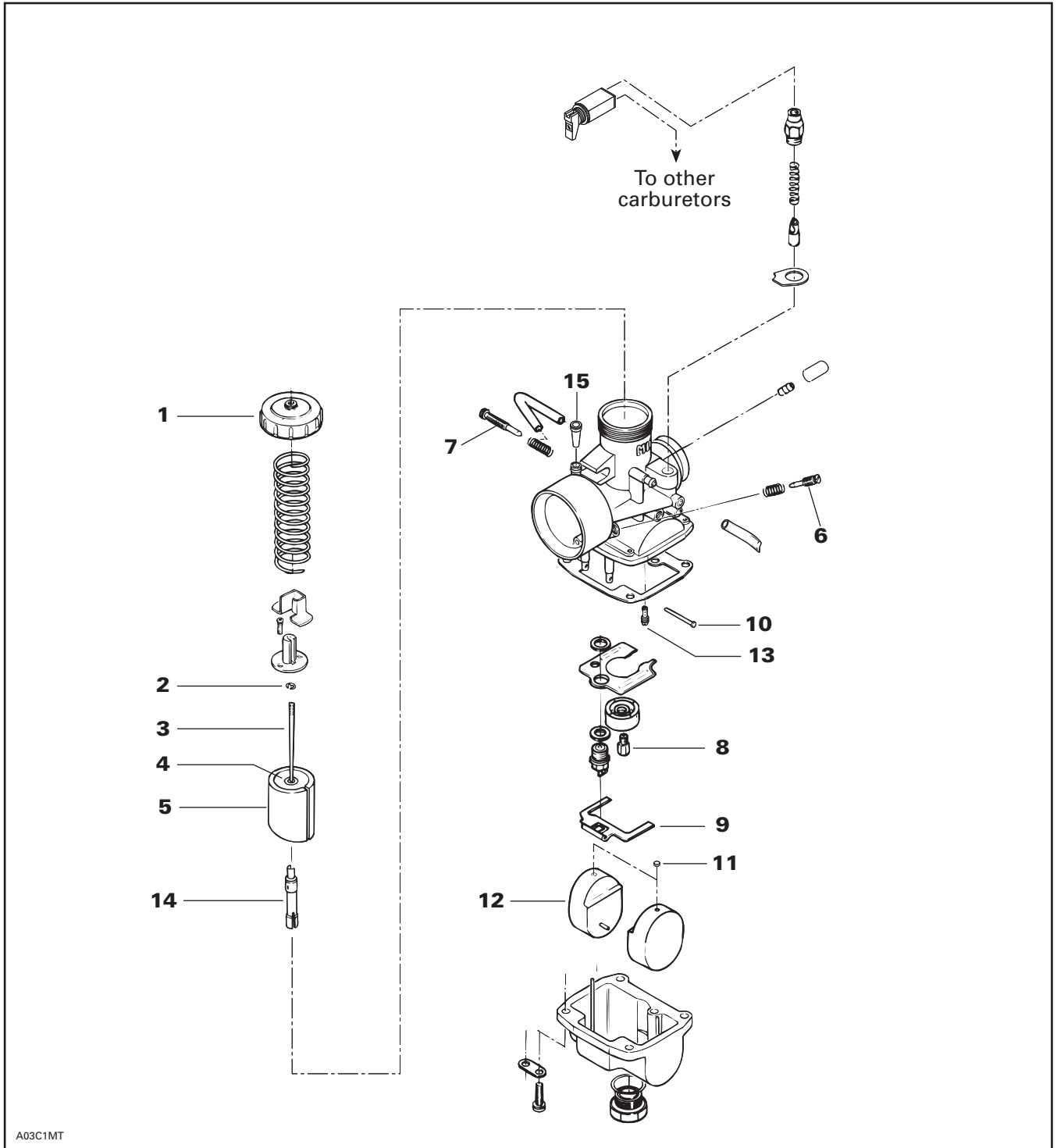

A03C1MT

Section 03 ENGINE

Sub-Section 08 (CARBURETOR AND FUEL PUMP)

Carburetor TM 38 C159

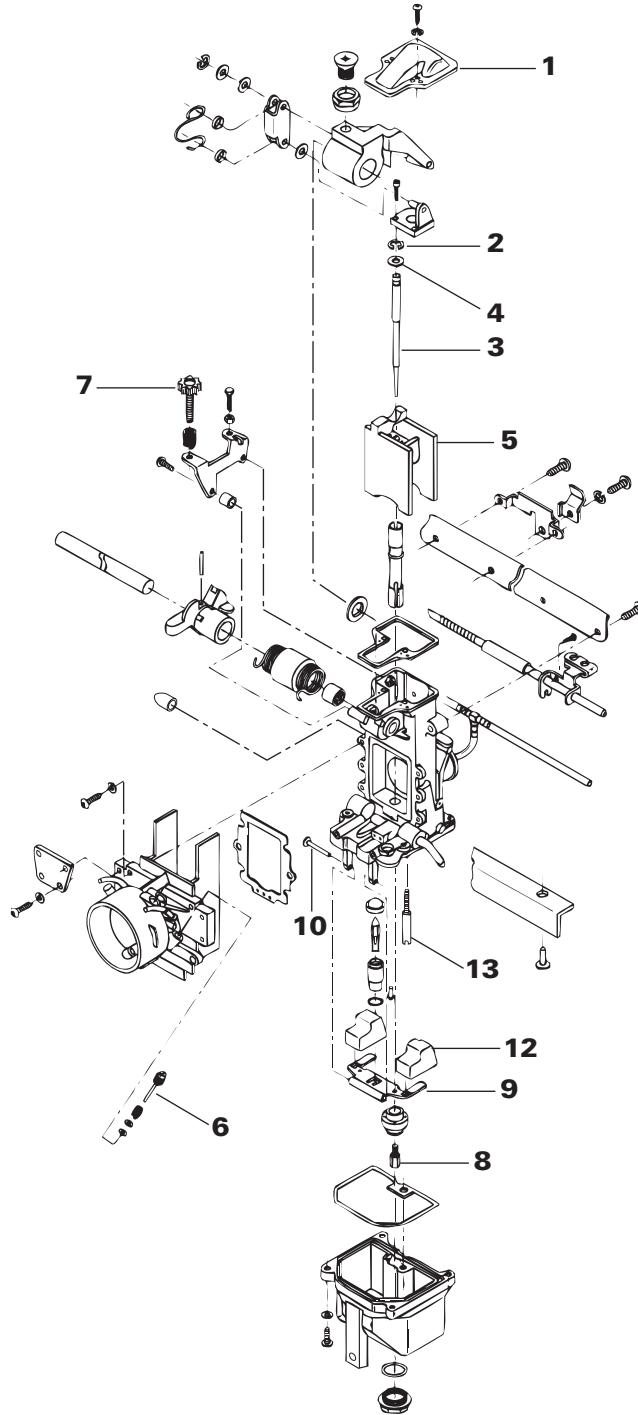

A06C38T

REMOVAL

Remove air silencers. Disconnect fuel inlet lines. Disconnect choke cable(s).

All Models Except Mach Z/Z LT

Unscrew carburetor cover no. 1 then pull out throttle slide no. 5 from carburetor.

 WARNING

<p>Exercise care when handling throttle slide. Scratches incurred may cause throttle slide to stick open in operation.</p>

Disconnect throttle cable from throttle slide.

Mach Z/Z LT

Disconnect throttle cable from throttle shaft.

All Models

Untighten rubber flange clamps then remove carburetor from engine.

CLEANING AND INSPECTION

The entire carburetor should be cleaned with a general solvent and dried with compressed air before disassembly.

 CAUTION

<p>Heavy duty carburetor cleaner may be harmful to the float material and to the rubber parts, O-rings, etc. Therefore, it is recommended to remove those parts prior to cleaning.</p>

Carburetor body and jets should be cleaned in a carburetor cleaner following manufacturer's instructions.

 WARNING

<p>Solvent with a low flash point such as gasoline, naphtha, benzol, etc., should not be used as they are flammable and explosive.</p>

15, Filter

Check for clogged filter. Clean or replace as required.

Check inlet needle tip condition. If worn, the inlet needle and seat must be replaced as a matched set.

NOTE: Install needle valve for snowmobile carburetor only. It is designed to operate with a fuel pump system.

Check throttle slide for wear. Replace as necessary.

Check idle speed screw straightness. Replace as necessary.

Check for fuel soaked into float no. 12; replace as necessary.

Check float for cracks or other damages affecting free movement; replace as necessary.

IDENTIFICATION

All carburetors are identified on their body.

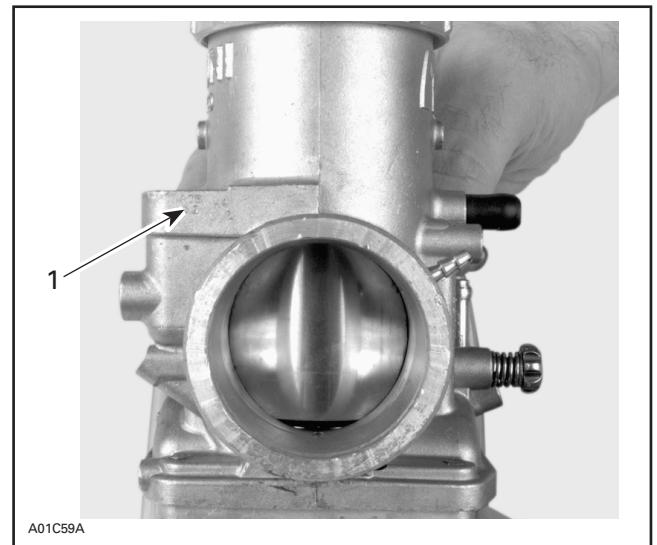

1. Identification: 34-482

Section 03 ENGINE

Sub-Section 08 (CARBURETOR AND FUEL PUMP)

DISASSEMBLY AND ASSEMBLY

NOTE: To ease the carburetor disassembly and assembly procedures it is recommended to use carburetor tool kit (P/N 404 1120 00).

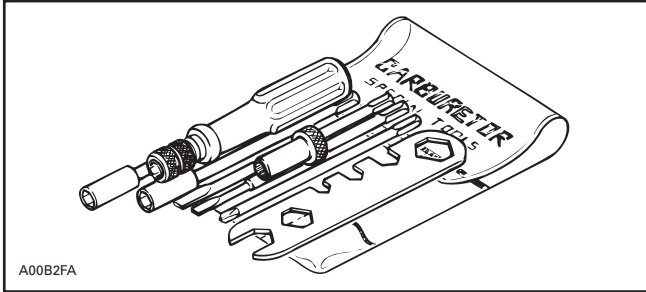

2,3, E-clip and Needle

All Models Except Mach Z/Z LT

Remove screws from needle retaining plate to withdraw the needle.

Mach Z/Z LT

To remove needle or to change its position or to remove throttle slide, remove carburetor cover.

Except for MAG side carburetor, unscrew locking screw and adjusting nut from throttle shaft.

Move arm aside just enough for unscrewing Allen screw retaining throttle slide.

For MAG side carburetor, raise throttle slide half way then unscrew Allen screws.

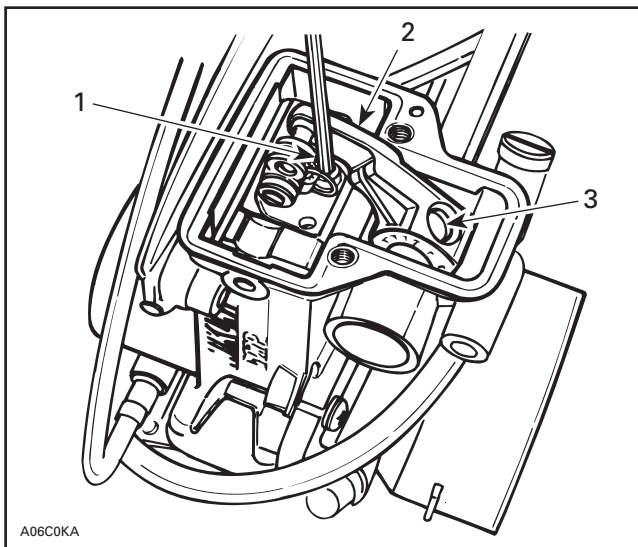

1. Allen screw
2. Arm moved aside
3. Locking screw and adjusting nut removed

All Models

The position of the needle in the throttle slide is adjustable by means of an E-clip inserted into 1 of 5 grooves located on the upper part of the needle. Position 1 (at top) is the leanest, 5 (at bottom) the richest.

NOTE: The last digit of the needle identification number gives the recommended position of the E-clip from the top of the needle.

Example: 6DH4-3
Needle identification ↑ ↑ Recommended position of the E-clip from top

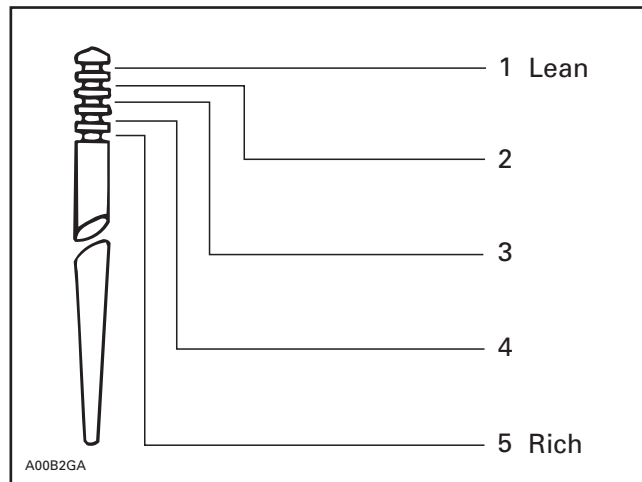

CLIP POSITIONS

The size of the throttle slide cut-away affects the fuel mixture between 1/8 to 1/2 throttle opening.

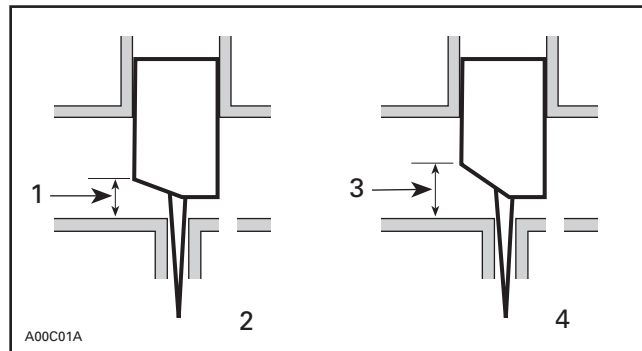

1. Low cut-away low
2. Rich mixture
3. High cut-away high
4. Lean mixture

8, Main Jet

The main jet installed in the carburetor has been selected for a temperature of -20°C (0°F) at sea level. Different jetting can be installed to suit temperature and/or altitude changes. Always check spark plug tip and/or piston dome color to find out correct jetting.

CARBURETOR FLOAT LEVEL ADJUSTMENT

9,10, Float Arm and Float Arm Pin

Correct fuel level in float chamber is vital toward maximum engine efficiency. To check for correct float level proceed as follows:

- Make sure that float arm is symmetric — not distorted.
- Remove float bowl and gasket from carburetor.

All Models Except Mach Z/Z LT

- With carburetor chamber upside-down on a level surface, measure height H between bowl seat and top edge of float arm. Keep ruler perfectly vertical and in line with main jet hole.

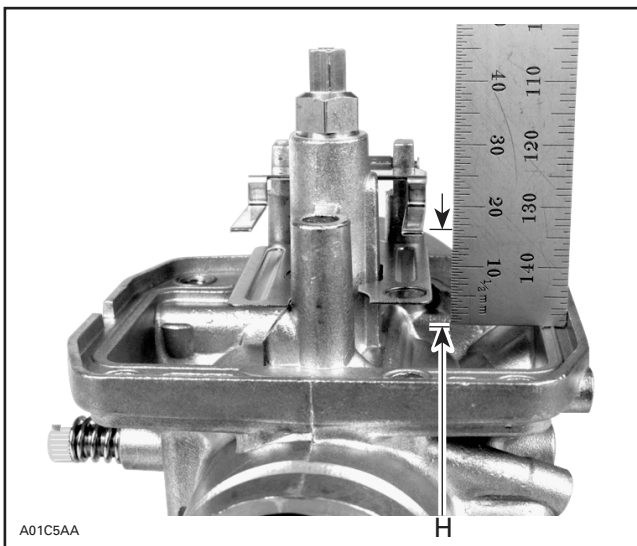

TYPICAL

H: Float height (including float arm thickness)

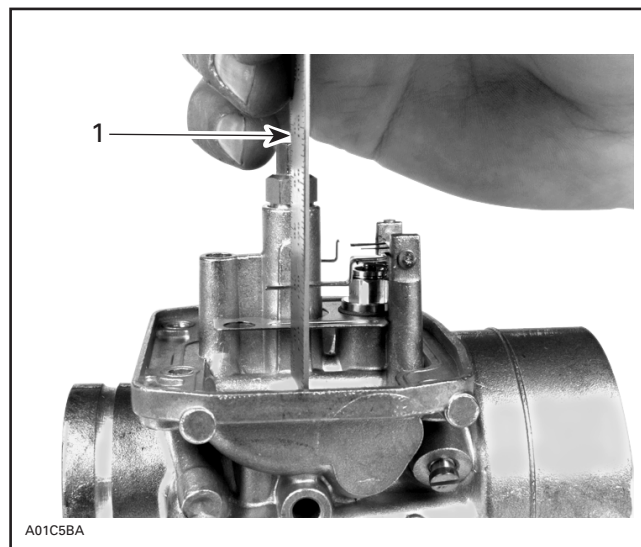

1. Ruler vertical and in line with main jet

Mach Z/Z LT

Do not turn carburetor up side down. Measure float arm height when it just touches needle valve without moving it.

CARBURETOR MODEL	FLOAT HEIGHT H	
	± 1 mm	(± .040 in)
Formula III/III LT	18.1	(.713)
Mach 1	18.1	(.713)
Mach Z/Z LT	20.0	(.787)

To Adjust Height H:

- Bend the contact tab of float arm until the specified height is reached.

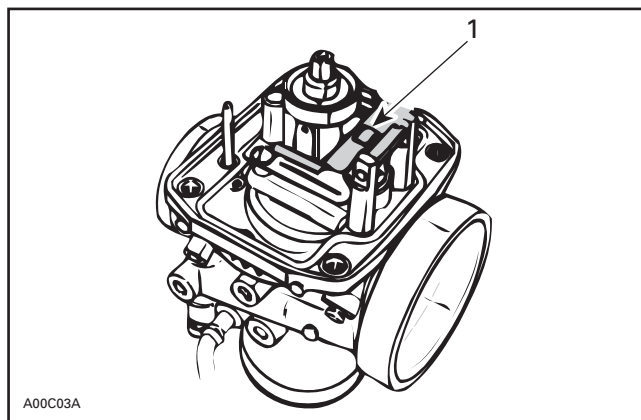

1. Contact tab

Section 03 ENGINE

Sub-Section 08 (CARBURETOR AND FUEL PUMP)

The following illustration shows the part of the carburetor which begins and stops to function at different throttle slide openings.

Note that the wider part of symbol corresponds to the opening mostly affected. For instance, throttle slide cut-away begins to function at closed position but it is most effective at 1/4 opening and decreases up to 1/2 opening.

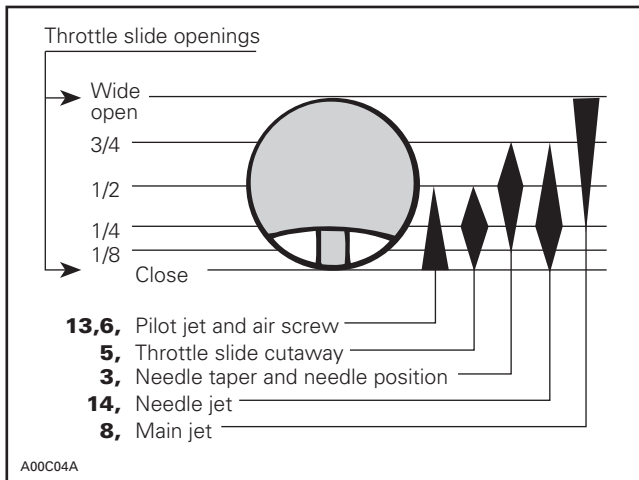

VIEW FROM AIR INTAKE OPENING

NOTE: For fine tuning refer to TECHNICAL DATA 09-02 and to SPARK PLUG 05-03.

NOTE: For high altitude regions, the *High Altitude Technical Data Booklet* (P/N 484 0648 00 and 484 0545 00 for binder) gives information about calibration according to altitude and temperature.

INSTALLATION

CAUTION

Never allow throttle slide(s) to snap shut.

To install carburetor on engine, inverse removal procedure.

However, pay attention to the following:

- Inspect throttle cable and housing prior to installation.

On applicable models, make sure to align tab of carburetor and air intake silencer (if applicable) with notch of adaptor(s). On applicable models, install adaptor with up mark facing up.

CAUTION

The rubber flange must be checked for cracks and/or damage. At assembly, the flange must be perfectly matched with the air intake manifold or severe engine damage will occur. Beside do not interchange carburetors, the jetting may be different on each side. A red dot is printed on MAG carburetor (blue on PTO side) and on the high tension coil support. Match the carburetor and the support dots.

Install clamps in a way that their tightening bolts are staggered — not aligned.

Hook throttle cable into the needle retainer plate.

NOTE: Do not obstruct hole in throttle slide when installing needle retaining plate. This is important to allow air escaping through and thus allowing a quick response.

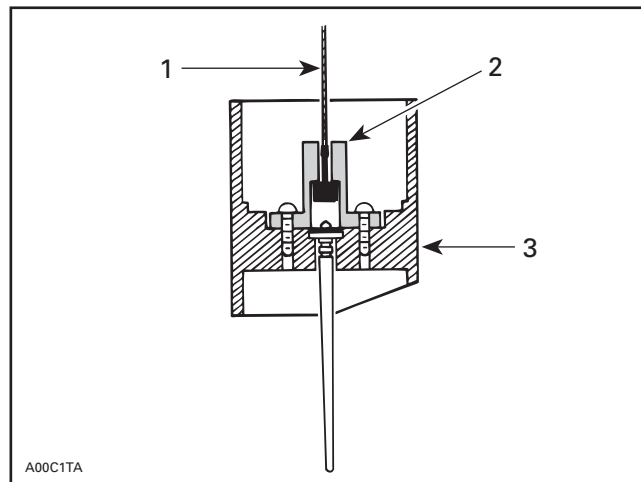

CENTER POST TYPE

1. Throttle cable
2. Needle retaining plate
3. Throttle slide

Make sure the nylon packing no. 4 is installed on all applicable throttle slides.

▼ CAUTION

Serious engine damage can occur if this notice is disregarded.

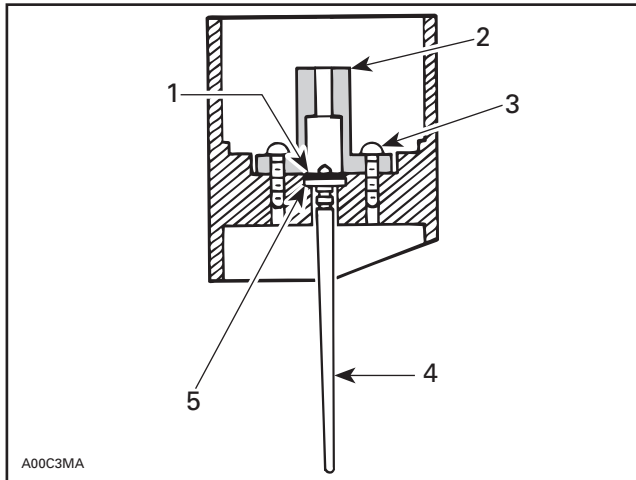

CENTER POST TYPE

1. E-clip
2. Needle retaining plate
3. Screw
4. Needle
5. Nylon packing

CARBURETOR ADJUSTMENTS

All Models Except Mach Z/Z LT

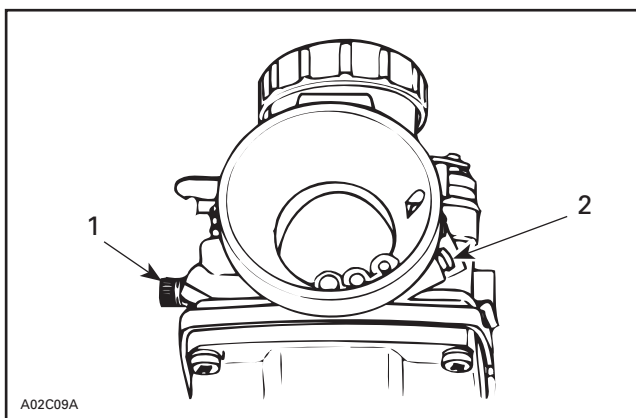

1. Idle speed screw
2. Air screw

Mach Z/Z LT

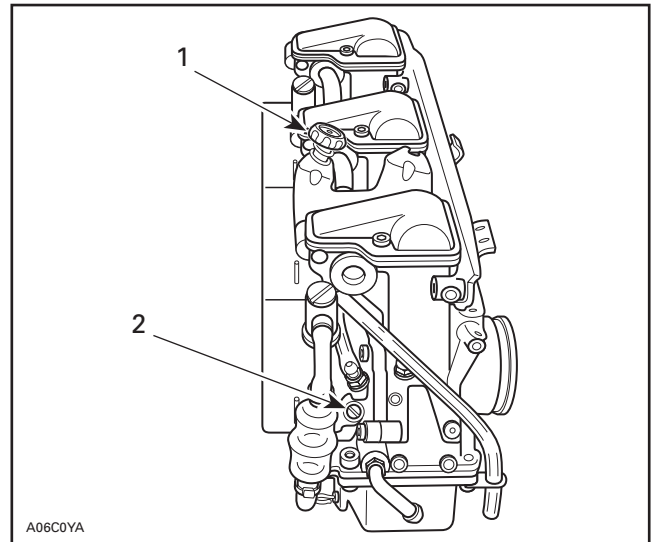

TYPICAL

1. Idle speed screw
2. Air screw (on each carburetor)

6, Air Screw Adjustment

All Models

Completely close the **air screw** (until a slight seating resistance is felt) then back off as specified.

Turning screw in clockwise enrichers mixture and conversely, turning it out counterclockwise leans mixture.

Refer to TECHNICAL DATA 09-02 for the specifications.

Carburetor Synchronization

All Models Except Mach Z/Z LT

All carburetor slides must start to open at the same time.

Completely unscrew idle speed screw on all carburetors.

Unlock cable adjustment lock nut then screw in adjuster until throttle slide bottoms out. Proceed the same for all carburetors.

Unscrew cable adjuster to eliminate all cable play but without raising throttle slide. Proceed with care on all carburetors then tighten jam nuts. All carburetor slide must start to open at the same time, depress throttle lever to check it and turn cable adjuster as required.

Section 03 ENGINE

Sub-Section 08 (CARBURETOR AND FUEL PUMP)

Check throttle slide position at wide open throttle. Throttle slide must be flush or 1 mm (.040 in) lower than carburetor **outlet** bore. At that same position, check that throttle slide does not contact carburetor cover. Turn cable adjuster and recheck synchronization.

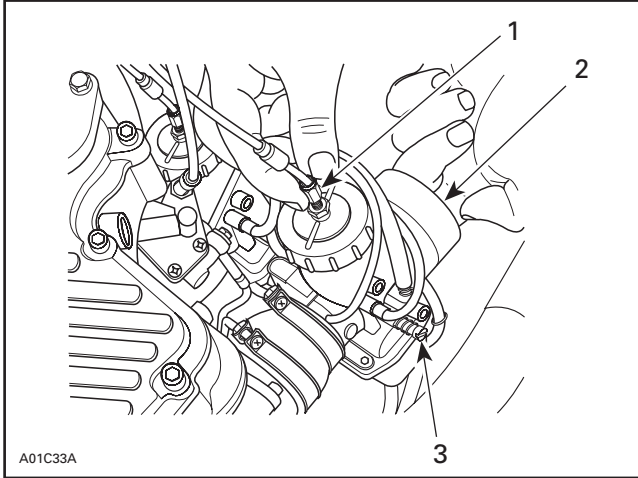

TYPICAL

1. Screw in and out until no cable free play exists
2. Check that throttle side does not move
3. Idle speed screw completely unscrewed



CAUTION

If the throttle slide rests against the carburetor cover at full throttle opening, this will create too much strain and may damage the throttle cable or other components in throttle mechanism.

Mach Z/Z LT

All 3 carburetor slides must start to open at the same time.

Visually check for simultaneous opening.

To adjust, remove carburetor covers, loosen locking screws (except for MAG carb.) and turn adjusting nuts accordingly.

Tighten locking screws and recheck synchronization.

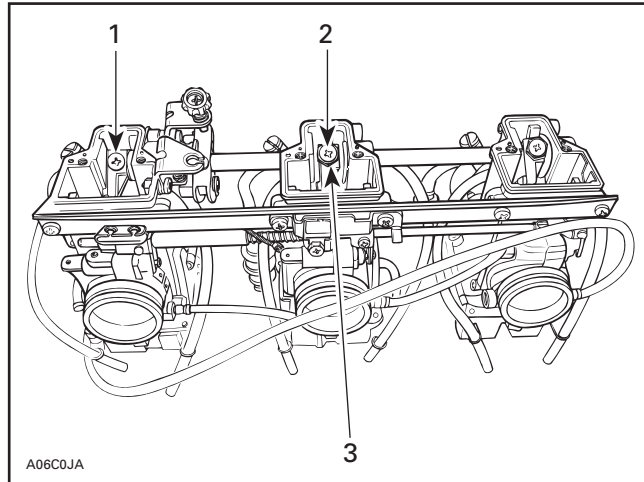

1. No adjustment on MAG side carburetor
2. Locking screws
3. Adjusting nut

NOTE: When using a vacuum gauge or a cylinder balancer or a Unisyn tool for checking carburetor synchronization, always remove 3 carburetor covers.

Full Throttle Adjustment

To avoid stress on throttle cable when throttle lever is against handlebar grip, stop screw must not contact stopper. There must be slight free play between stop screw and its stopper.

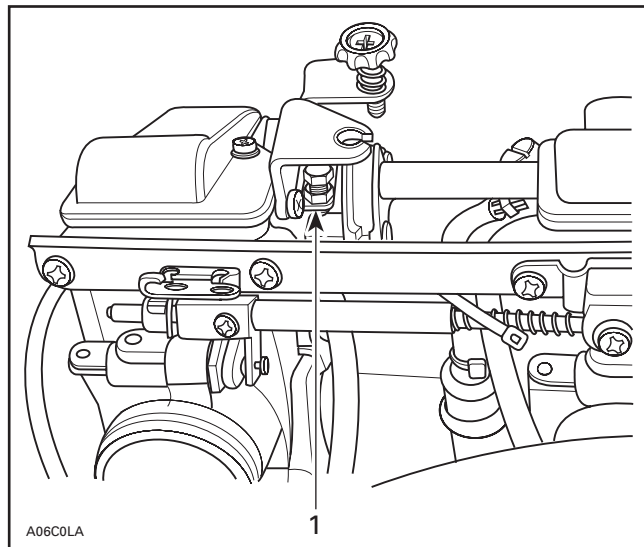

TYPICAL — FULL THROTTLE POSITION

1. Free play between stop screw and its stopper

Throttle Slide Adjustment

All Models Except Mach Z/Z LT

<p>◆ WARNING</p>
<p>Ensure the engine is turned OFF, prior to performing the throttle slide adjustment.</p>

For maximum performance, correct carburetor throttle slide adjustment is critical.

The following method should be used with engine turned off:

- **Idle speed** screw must be completely unscrewed. It must not contact throttle slide.

Turn the **idle speed** screw clockwise until it contacts the throttle slide then continue turning 2 additional turns.

Repeat on the other carburetors. This will ensure identical throttle slide preliminary idle setting. Re-check carburetor synchronization. Adjust idle by turning all idle speed screws of the same amount.

<p>▼ CAUTION</p>
<p>Make sure all carburetors start to operate simultaneously.</p>

<p>▼ CAUTION</p>
<p>The oil injection pump adjustment must be checked each time carburetor is adjusted. Refer to OIL INJECTION SYSTEM 03-05.</p>

All Models Except Mach Z/Z LT

Throttle slide must be flush or 1.0 mm (.040 in) lower than the top of carburetor **oulet** bore (engine side).

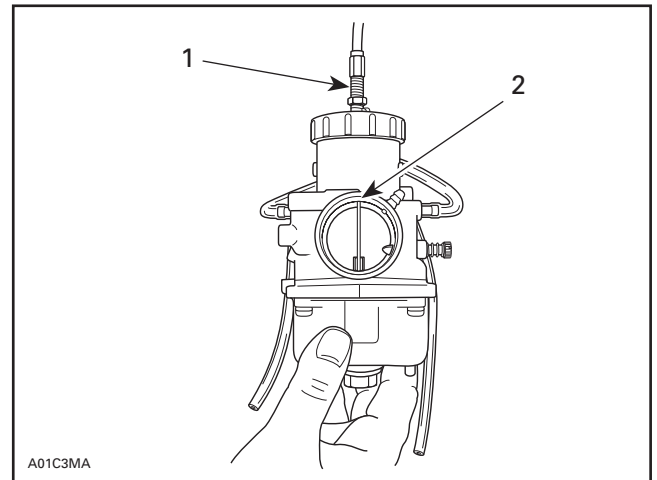

THROTTLE LEVER AGAINST HANDLE GRIP

1. Throttle cable adjuster
2. Throttle slide flush or 1.0 mm (.040 in) lower than carburetor outlet bore (engine side)

Once carburetor adjustment is performed, check that **with the throttle lever fully depressed**, there is a free play between the carburetor cover and top of throttle slide.

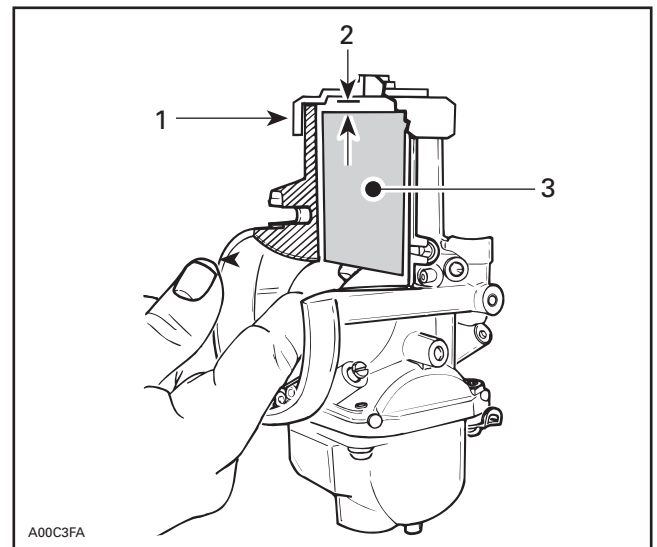

THROTTLE LEVER AGAINST HANDLE GRIP

1. Cover
2. Free play
3. Throttle slide

Section 03 ENGINE

Sub-Section 08 (CARBURETOR AND FUEL PUMP)

◆ WARNING

This gap is very important. If the throttle slide rests against the carburetor cover at full throttle opening, this will create too much strain and may damage the throttle cable or other components in throttle mechanism.

Recheck carburetor synchronization.

▼ CAUTION

The oil injection pump adjustment must be checked each time carburetor is adjusted. Refer to OIL INJECTION SYSTEM 03-05.

PRELIMINARY IDLE SPEED ADJUSTMENT

Adjust throttle slide height (see table) by turning idle speed screw no. 7.

Final adjustment (engine running at idle speed) should be within 1/2 turn of idle speed screw from preliminary adjustment.

Models	Throttle Slide Height mm (in)
Formula III/III LT	1.2 (.047)
Mach 1	1.4 (.055)
Mach Z/Z LT	1.3 (.051)

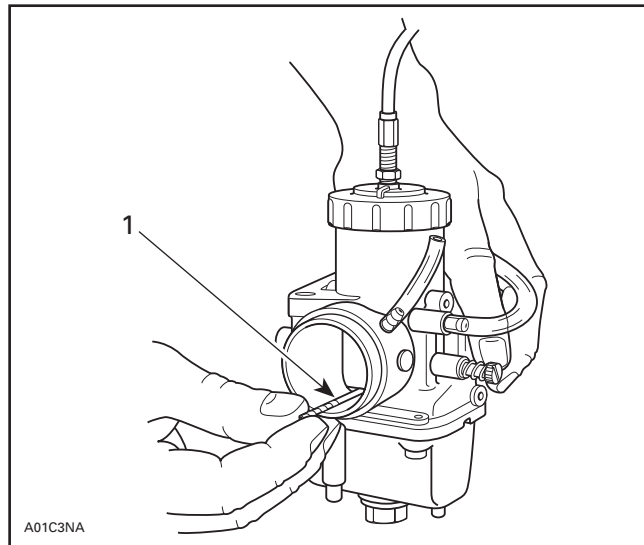

TYPICAL

1. Drill bit used as gauge for throttle slide height

IDLE SPEED FINAL ADJUSTMENT

7, Idle Speed Screw

Start engine and allow it to warm then adjust idle speed to specifications by turning **idle speed** screw clockwise to increase engine speed or counterclockwise to decrease it.

NOTE: Turn adjustment screw the same amount on all carburetors to keep carburetors synchronized.

Refer to TECHNICAL DATA 09-02 for the specifications.

▼ CAUTION

Do not attempt to set the idle speed by using the air screw. Severe engine damage can occur.

CHOKER

All Models Except Mach Z/Z LT

Choke Plunger Adjustment

Set choke lever to fully open position.



CHOKER LEVER — FULLY OPEN POSITION

Insert choke plunger tool into choke air inlet of each carburetor.

▼ CAUTION

Make sure that tool stopper is properly lean on venturi recess. This will ensure that tool tip is properly seated under choke plunger, as shown on the next photos.

NOTE: Choke plunger tool can be used both sides depending on carburetor type. Use larger diameter for Mikuni 38 mm and smaller diameter for Mikuni 34 mm.

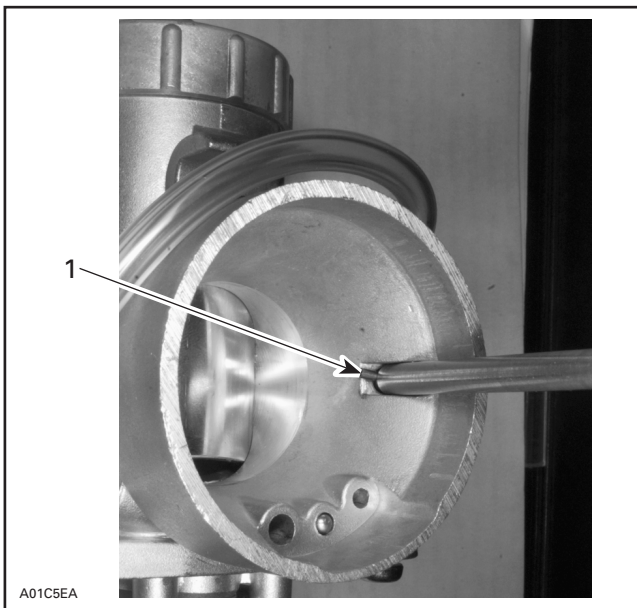

AIR SILENCER SIDE SHOWN

1. Tool stopper properly leaned on venturi recess

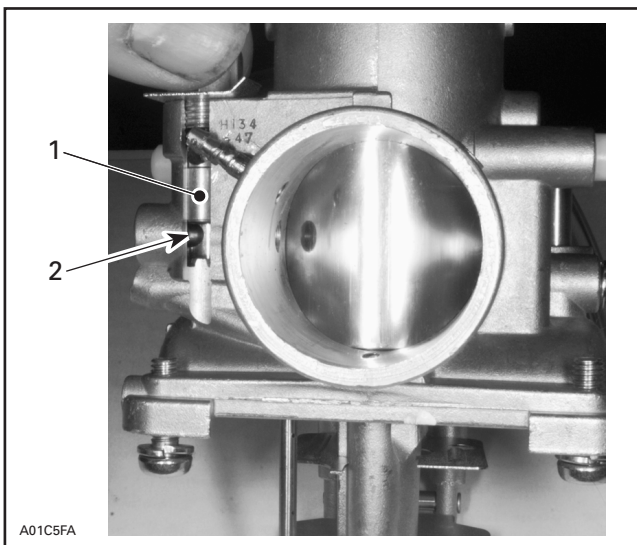

ENGINE SIDE SHOWN (CUTAWAY)

1. Choke plunger
2. Tool properly seated under choke plunger

If tool tip does not seat under choke plunger, adjust as follows:

Lift up protector cap and loosen choke cable lock nut, as shown in the next photo.

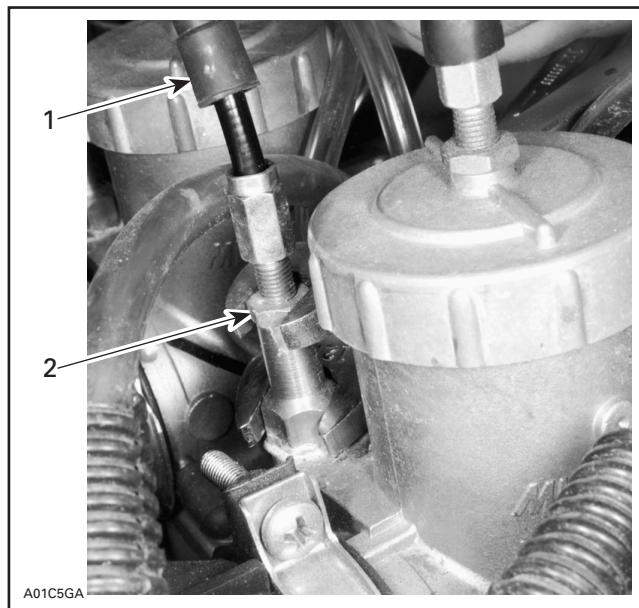

1. Lift up protector cap
2. Loosen lock nut

Set choke lever to fully open position.

Turn choke cable adjustment nut by hand until tool properly seats under choke plunger.

NOTE: A light pressure should be needed to position tool under plunger.

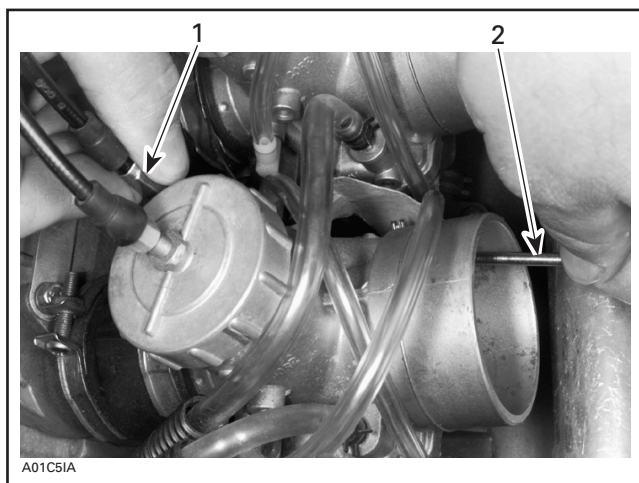

1. Choke cable adjustment nut
2. Choke plunger tool

Tighten choke cable lock nut and reinstall protector cap.

Section 03 ENGINE

Sub-Section 08 (CARBURETOR AND FUEL PUMP)

Set choke lever to close and open positions and ensure that tool properly seats under plunger **only** when lever is set to fully open position.

Set choke lever to close position and, by pulling and pushing choke lever, make sure there is no tension on cable (free play).



CHOKE LEVER — CLOSED POSITION

Mach Z/Z LT

Choke Rod

Check for free movement of choke rod. If hard to slide, remove 3 plunger ferrules then choke rod.

Thoroughly clean choke rod and its mounting hole on each carburetor.

Remove plunger grommet from each carburetor. Fill the grommet interior with dielectric grease (P/N 413 7017 00). Reinstall the grommets.

Apply dielectric grease (P/N 413 7017 00) on choke rod and reinstall it with its retrun spring and spacer on PTO side. Make sure that ferrule screws align with each rod hole. Tighten screws to 2 N•m (18 lbf•in).

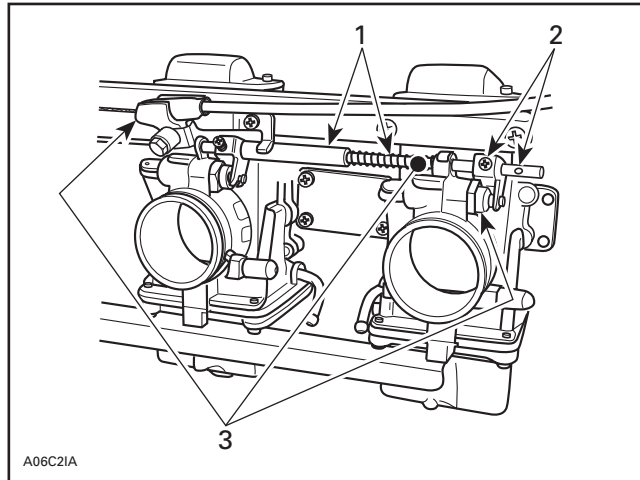

1. Spacer and spring on PTO side
2. Ferrule screw aligned with rod hole
3. Dielectric grease

Apply dielectric grease (P/N 413 7017 00) on cable housing end.

All 3 plungers must start to open at the same time. Bend ferrule end as required. Do not change position of ferrule on rod. Its screw must remain in line with choke rod hole.

Choke Cable Adjustment

Choke cable barrel must be in left hole of sliding rod lever.

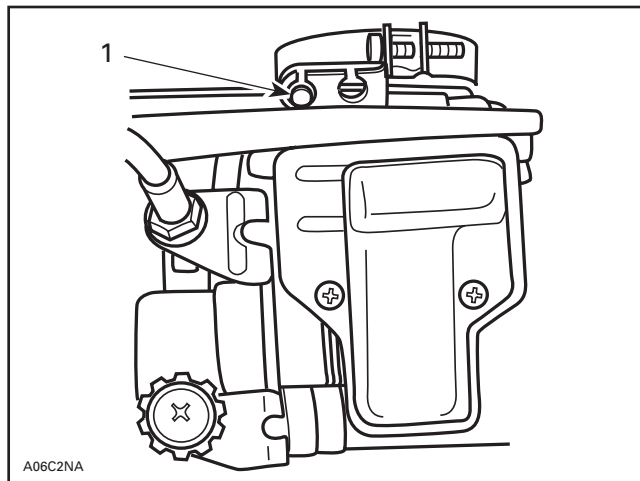

1. Cable barrel in left hole

Air intake silencer must be reinstalled and choke cable properly routed before finalizing adjustment.

Adjust choke cable to obtain a maximum gap of approximately 0.3 mm (.012 in) between tab and plunger when choke lever is not activated.

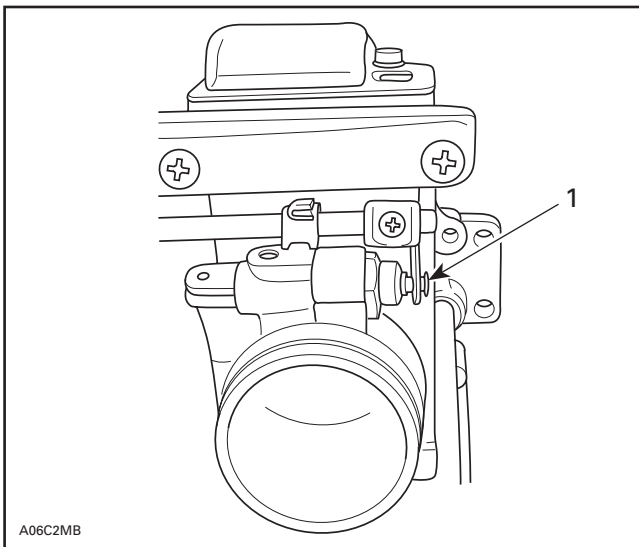

1. 0.3 mm (.012 in) gap maximum

NOTE: If there is no gap between tab and plunger, a rich condition will occur and throttle response will be affected; if the gap is too great, the plunger stroke will be reduced causing poor cold engine starting.

If adjustment is required, loosen cable support on middle carburetor to change choke cable position.

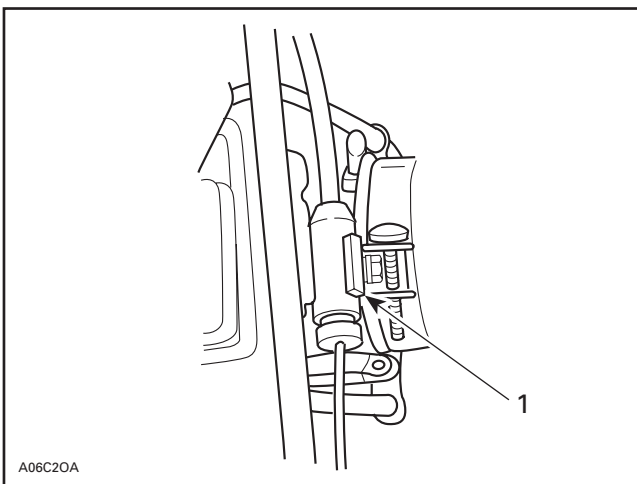

1. Choke cable support

After adjustment, retighten screw.

Section 03 ENGINE

Sub-Section 08 (CARBURETOR AND FUEL PUMP)

FUEL PUMP

All Models

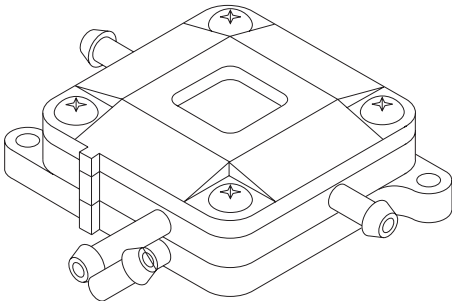

A06C3SS

REMOVAL

Install a hose pincer (P/N 529 0099 00) on fuel supply line close to pump inlet.

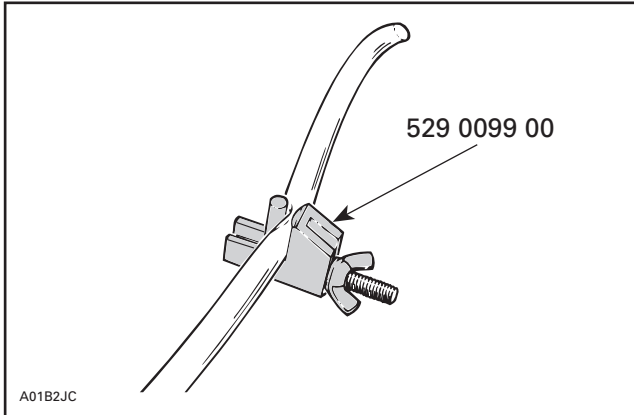

Disconnect fuel outlet line(s).
 Disconnect impulse line.
 Remove screws securing fuel pump.

PUMP VERIFICATION

Check fuel pump valves operation as follows:

Connect a clean plastic tubing to the inlet nipple and alternately apply pressure and vacuum with pump or leak test kit. The inlet valve should release with pressure and hold under vacuum.

Repeat the same procedure at the outlet nipple. This time the outlet valve should hold with pressure and release under vacuum.

NOTE: On model fitted with 2 outlets, plug 1 outlet with finger while checking outlet valve.

Check impulse diaphragm and gasket on high-supply fuel pump with twin outlets as follows:

Connect a clean plastic tubing to the impulse nipple and plug vent hole on top cover. Either apply pressure or vacuum. The diaphragm/gasket must not leak.

CLEANING AND INSPECTION

The entire pump should be cleaned with general purpose solvent before disassembly.

Fuel pump components should be cleaned in general purpose solvent and dried with compressed air.

◆ WARNING

Solvent with a low flash point such as gasoline, naphtha, benzol, etc., should not be used as each is flammable and explosive.

Inspect diaphragm. The pumping area should be free of holes, tears or imperfections. Replace as needed.

High-supply pump with twin outlets: Thoroughly clean filter on top cover. Replace pump if too dirty.

INSTALLATION

To install, inverse removal procedure.

◆ WARNING

Pressure test to ensure there is no leak in fuel system.

FUEL TANK AND THROTTLE CABLE

Fuel Tank Lines

◆ WARNING

When draining a fuel tank or whenever a fuel line is disconnected, obstruct line with a hose pincher (P/N 529 0099 00) or equivalent device. Fuel is flammable and explosive under certain conditions. Ensure work area is well ventilated. Do not smoke or allow open flames or sparks in the vicinity.

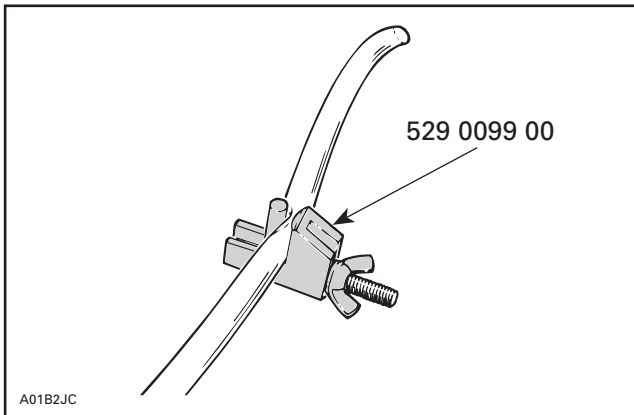

Impulse/Fuel Lines Spring Clips (all models)

Always reposition spring clips after any repair to prevent possible leaks.

Throttle Cable Circlip at Handlebar (all models)

Put silicone grease (P/N 413 7017 00) around cable barrel. Locate circlip as per illustration.

◆ WARNING

If this procedure is disregarded, throttle might be half-open at normally closed position and the engine will speed up when starting.

Models with Easy Action Throttle Lever

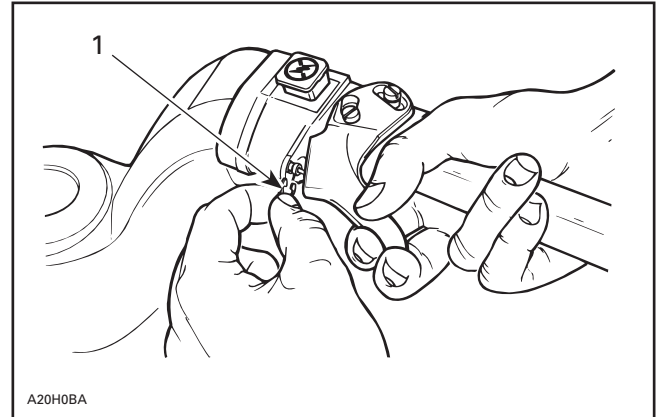

TYPICAL

1. Circlip

Other Models

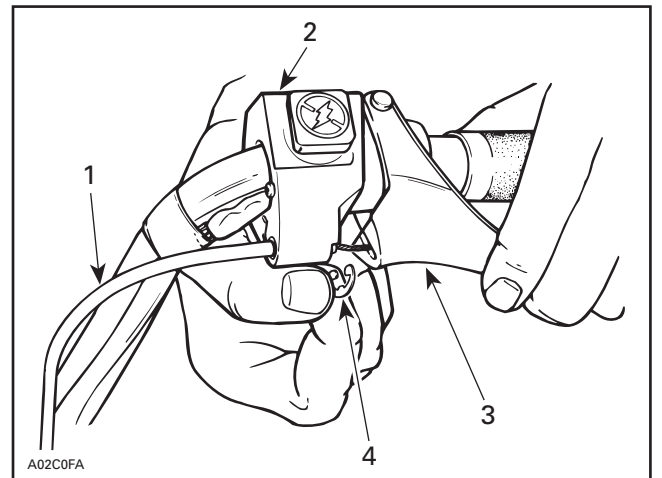

TYPICAL

1. Throttle cable housing
2. Throttle handle housing
3. Throttle handle
4. Circlip

Section 03 ENGINE

Sub-Section 09 (FUEL TANK AND THROTTLE CABLE)

Throttle Cable O-ring and Retaining Ring at Carburetor (some models)

Locate O-ring outside of carburetor cover and retaining ring inside.

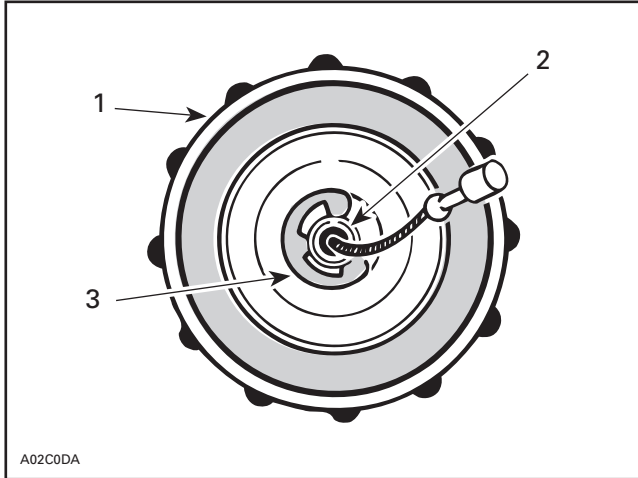

1. Carburetor cover
2. Throttle cable housing
3. Retaining ring

Adjust throttle cable as specified in CARBURETOR AND FUEL PUMP 03-08.

Throttle Cable Routing

▼ CAUTION

Check that throttle cable is routed away from sharp edges, hot or vibrating parts. When turning steering while engine is running, idle speed must not vary.

Fuel Level Sensor

Inspection

Visually inspect the condition of connectors and wiring throughout the circuit. Connections must be clean and tight, and wiring free of damage. Repair as necessary. Use silicone dielectric grease to prevent corrosion at the connectors. Operate the engine to see if the problem has been corrected. If not, remove fuel level sensor from fuel tank and check rod angle (100.7°), resistance at full position ($3 \pm 2 \Omega$) and resistance at empty position ($110 \pm 7 \Omega$).

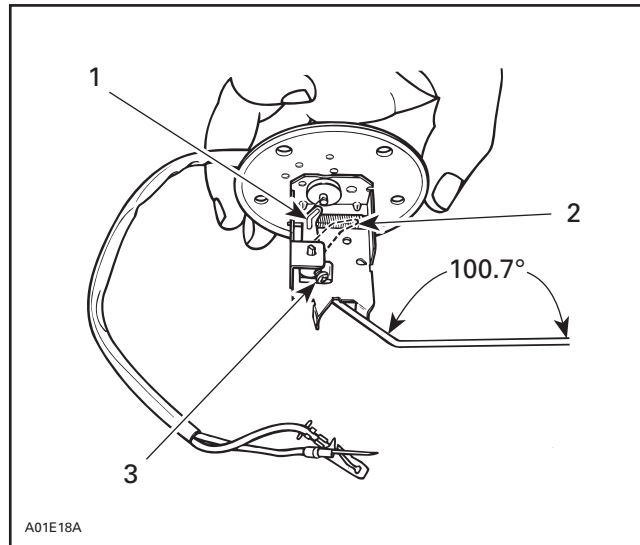

1. Full position ($3 \pm 2 \Omega$)
2. Empty position ($110 \pm 7 \Omega$)
3. Loosen to adjust

Fuse replacement

A 0.25 ampere fuse protects fuel level sensor circuitry. Remove seat to gain access.

Fuel Level Sensor Screws

Torque fuel level sensor retaining screws to $1 \text{ N}\cdot\text{m}$ ($8 \text{ lbf}\cdot\text{in}$) in the sequence shown and then to $2.5 \text{ N}\cdot\text{m}$ ($22 \text{ lbf}\cdot\text{in}$), using the same sequence.

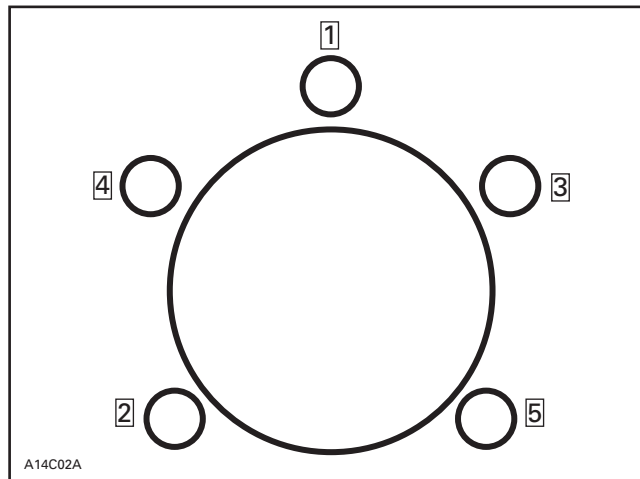

TABLE OF CONTENTS

DRIVE BELT	04-02-1
1997 APPLICATION CHART	04-02-1
ROTATION DIRECTION.....	04-02-1
DRIVE BELT DEFLECTION MEASUREMENT	04-02-2
DEFLECTION ADJUSTMENT.....	04-02-3

DRIVE PULLEY	04-03-1
TRA	04-03-1
GENERAL	04-03-2
REMOVAL.....	04-03-2
DISASSEMBLY.....	04-03-3
CLEANING	04-03-4
INSPECTION	04-03-5
ASSEMBLY.....	04-03-6
INSTALLATION	04-03-8
DRIVE PULLEY ADJUSTMENT.....	04-03-9

DRIVEN PULLEY	04-04-1
REMOVAL.....	04-04-2
DISASSEMBLY.....	04-04-2
CLEANING	04-04-2
INSPECTION	04-04-2
ASSEMBLY.....	04-04-4
INSTALLATION	04-04-4
ADJUSTMENT	04-04-5

PULLEY DISTANCE AND ALIGNMENT	04-05-1
GENERAL	04-05-1
GENERAL PROCEDURE	04-05-1
PULLEY ALIGNMENT AND DISTANCE SPECIFICATIONS CHART.....	04-05-2

BRAKE	04-06-1
HYDRAULIC DISC BRAKE	04-06-1
REMOVAL.....	04-06-2
DISASSEMBLY.....	04-06-3
CLEANING	04-06-3
INSPECTION	04-06-3
ASSEMBLY.....	04-06-3
INSTALLATION	04-06-4
ADJUSTMENT	04-06-4
BLEEDING	04-06-5

Section 04 TRANSMISSION

Sub-Section 01 (TABLE OF CONTENTS)

CHAINCASE	04-07-1
REMOVAL	04-07-2
INSPECTION	04-07-2
GEAR RATIO MODIFICATION.....	04-07-2
INSTALLATION	04-07-2
DRIVE CHAIN ADJUSTMENT.....	04-07-3
ADJUSTMENT.....	04-07-4

DRIVE CHAIN	04-08-1
SILENT CHAIN.....	04-08-1

DRIVE BELT

1997 APPLICATION CHART

MODEL	PART NUMBER	WIDTH (NEW) ± 0.25 mm (.010 in)	MINIMUM WIDTH (WEAR LIMIT)
FORMULA III/III LT, MACH 1/Z/Z LT	415 0603 00	35 mm (1-3/8")	33 mm (1-19/64")

ROTATION DIRECTION

The maximum drive belt life span is obtained when the drive belt is installed as shown. This will ensure that correct direction of rotation is respected.

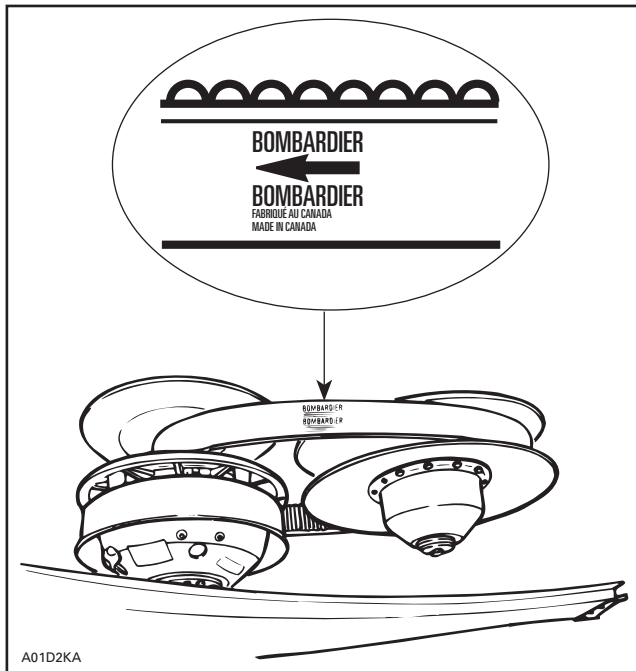

CORRECT

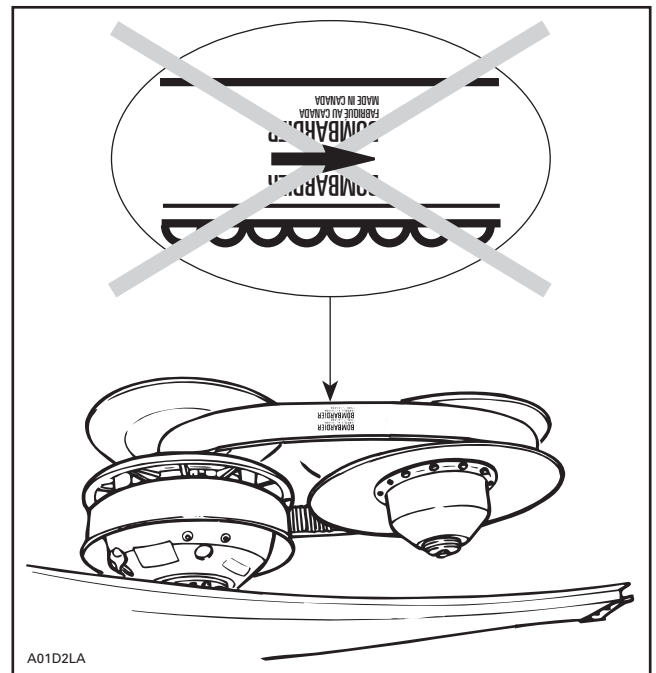

INCORRECT

NOTE: For used drive belt, mark and reinstall in the same position.

Section 04 TRANSMISSION

Sub-Section 02 (DRIVE BELT)

DRIVE BELT DEFLECTION MEASUREMENT

NOTE: The drive belt deflection measurement must be performed each time a new drive belt is installed.

NOTE: To obtain an accurate drive belt deflection measurement, it is suggested to allow a break-in period of 50 km (30 mi).

Before checking the belt deflection, ensure vehicle has the proper belt (Refer to the application chart).

Adjust pulley distance and alignment. Refer to PULLEY DISTANCE AND ALIGNMENT 04-05 .

To obtain maximum vehicle performance, the belt tension must be adjusted according to specifications shown in the accompanying chart.

MODEL	DEFLECTION mm (in)	FORCE kg (lb)	HEIGHT† OVER DRIVEN PULLEY
All Models	32 ± 5 (1-1/4 ± 13/64)	11.3 (25)	0 - 1.5 mm (0 - 1/16")

†FOR REFERENCE ONLY

To Check Tension

Position a reference rule on drive belt.

Wooden Stick and Spring Scale Method:

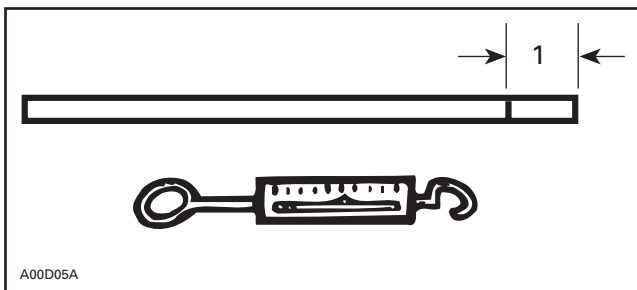

1. Mark specified deflection

Using spring scale and stick, apply specified force on drive belt halfway between pulleys as shown.

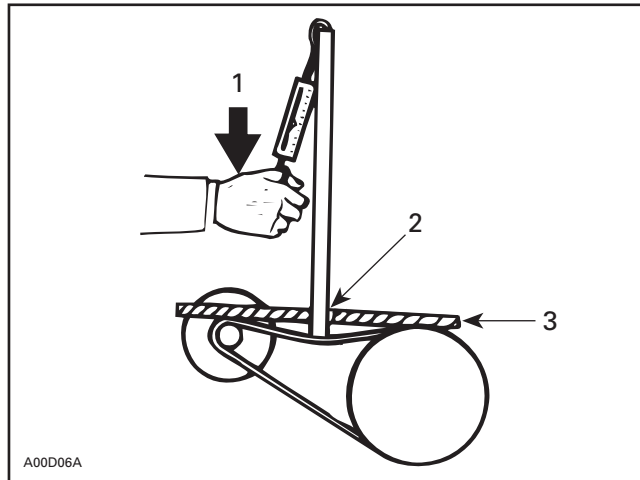

1. Force
2. Read deflection here
3. Reference rule

Or use the belt tension tester (P/N 414 3482 00).

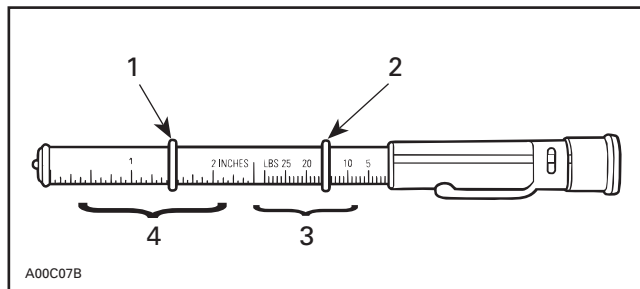

1. Lower O-ring
2. Upper O-ring
3. Force (Read Down)
4. Deflection (Read Up)

1. Slide lower O-ring of deflection scale to specified measure.
2. Slide upper O-ring to zero on the force scale.
3. Apply pressure until lower O-ring is flush with edge of rule and read force on the upper scale at top edge of O-ring.

Section 04 TRANSMISSION

Sub-Section 02 (DRIVE BELT)

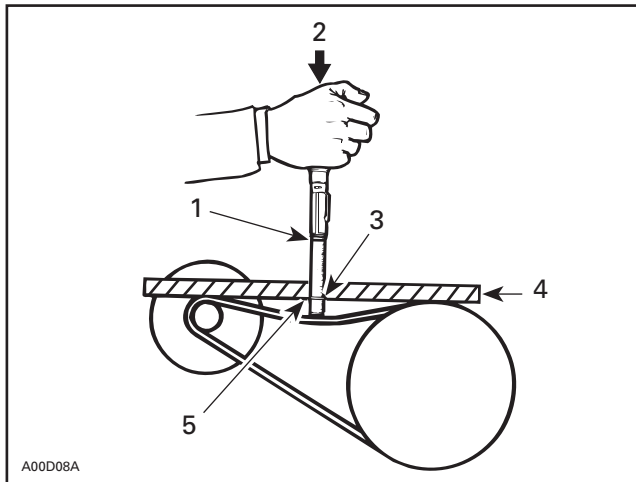

1. Upper O-ring
2. Force
3. Lower O-ring
4. Reference rule
5. Deflection

DEFLECTION ADJUSTMENT

Adjust pulley distance according to specification, refer to PULLEY DISTANCE AND ALIGNMENT 04-05, then adjust drive belt deflection using Allen screws, as shown.

To increase deflection: turn Allen screws clockwise.

To decrease deflection: turn Allen screws counterclockwise.

NOTE: Turn Allen screws 1/4 turn at a time, then rotate driven pulley to allow drive belt to settle in pulley. Check deflection, repeat as required.

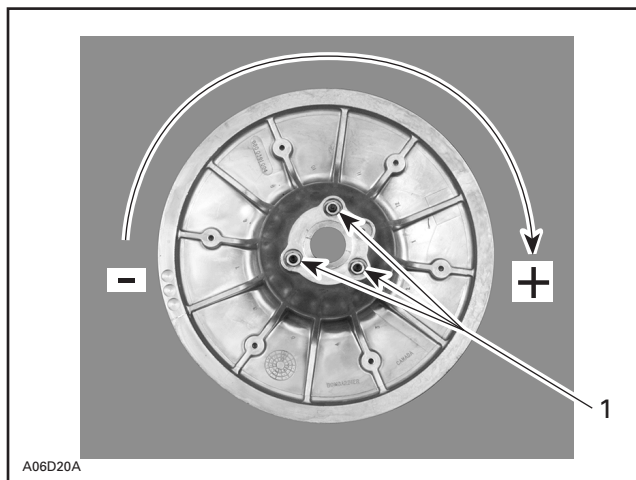

1. Allen screw with jam nut

Allen screws should be restrained while tightening jam nut to prevent throwing adjustment out. Use drive belt tension adjuster (P/N 529 0087 00).

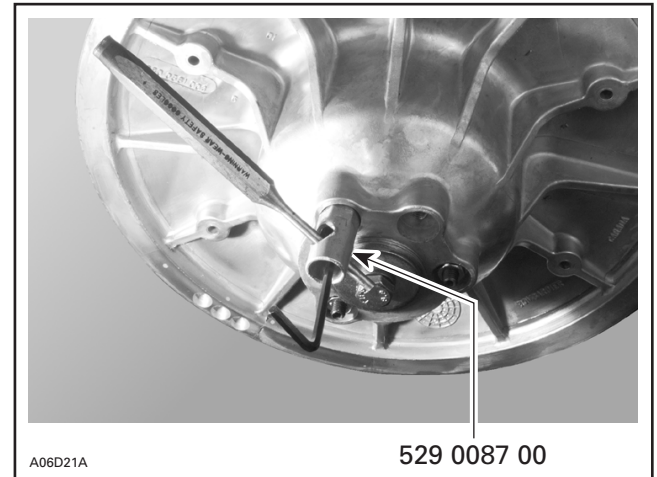

Restrain Allen screws with the wrench and tighten nut with the socket using socket handle provided in tool box.

DRIVE PULLEY

TRA

All Models

NOTE: This is a lubrication free drive pulley.

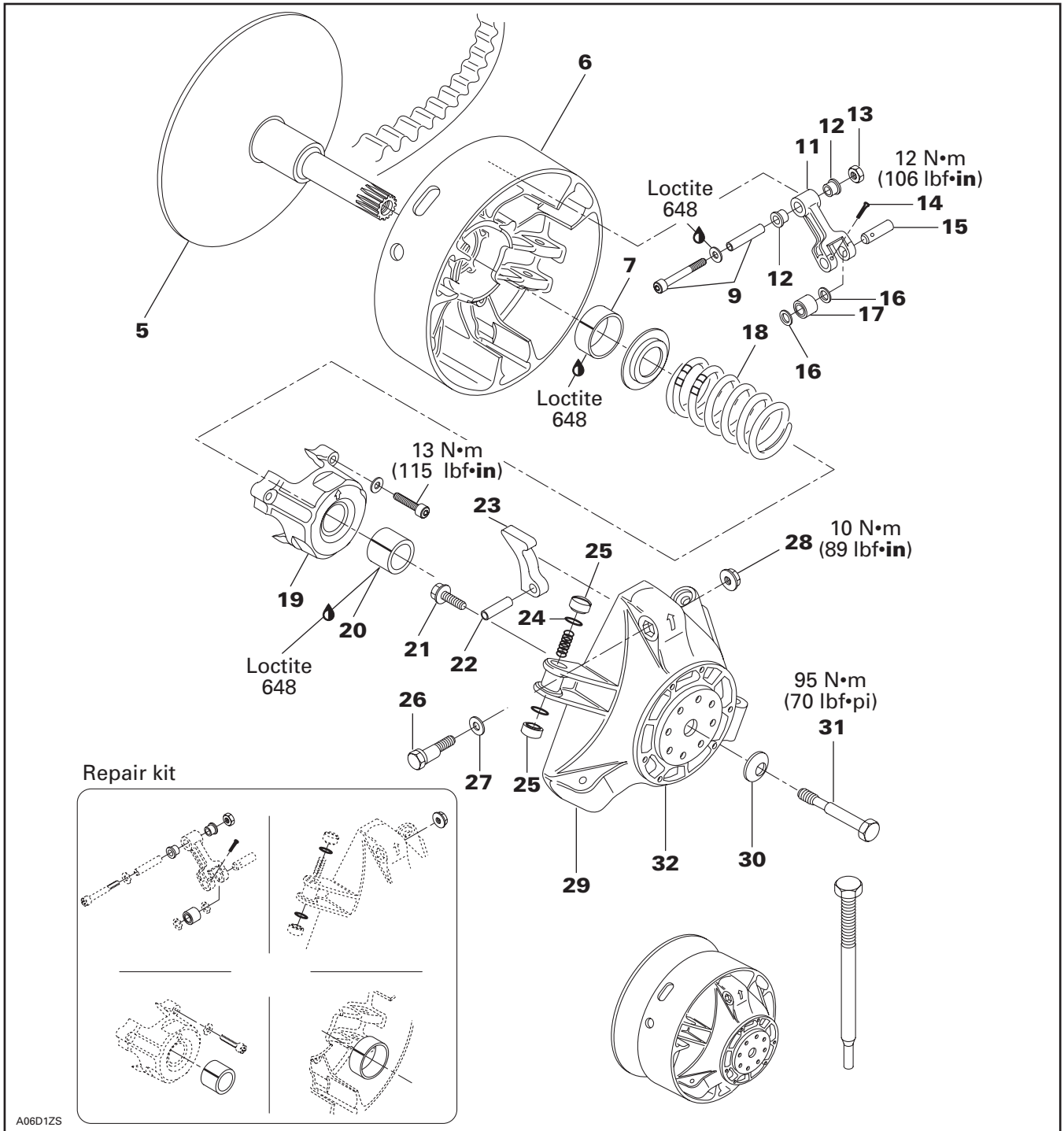

A06D1ZS

Section 04 TRANSMISSION

Sub-Section 03 (DRIVE PULLEY)

GENERAL

Some drive pulley components (return spring, ramp) can be changed to improve vehicle performance in high altitude regions. The *High Altitude Technical Data* booklet (P/N 484 0648 00 and 484 0545 00 for binder) gives information about calibration according to altitude.

▼ CAUTION

Such modifications should only be performed by experienced mechanics since they can greatly affect vehicle performance. Verify spring specifications before installation. Do not only refer to the spring color code.

NOTE: TRA clutch stands for Total Range Adjustable clutch.

◆ WARNING

Any drive pulley repairs must be performed by an authorized Bombardier snowmobile dealer, or other such qualified person. Sub-component installation and assembly tolerances require strict adherence to procedures detailed.

REMOVAL

30,31, Conical Spring Washer and Screw

Use clutch holder (P/N 529 0064 00).

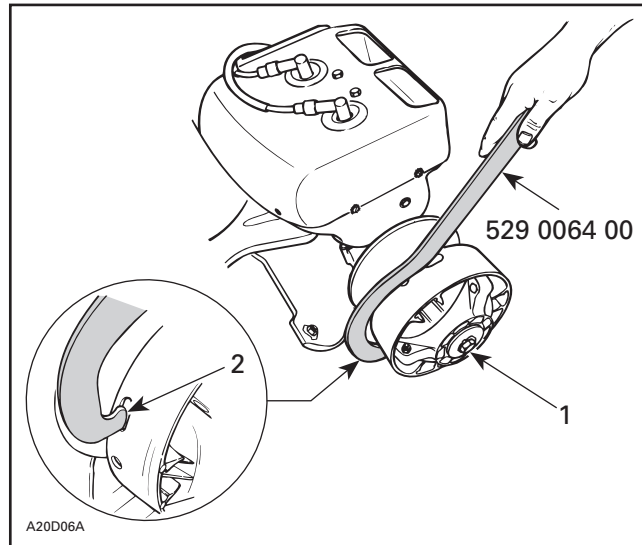

TYPICAL

1. Retaining screw
2. Insert in any slot

NOTE: Sliding half can be removed while fixed half remains on crankshaft.

◆ WARNING

Never use any type of impact wrench at drive pulley removal and installation.

Remove retaining screw.

To remove drive pulley ass'y and/or fixed half from engine, use puller (P/N 529 0224 00).

▼ CAUTION

These pulleys have metric threads. Do not use imperial threads puller. Always tighten puller by hand to ensure that the drive pulley have the same type of threads (metric vs imperial) prior to fully tighten.

To Remove Drive Pulley Ass'y:
Retain drive pulley with clutch holder.
Install puller in pulley shaft then tighten.

DISASSEMBLY

1,2, Screw and Ring Gear

▼ CAUTION
Retaining screws must be heated before disassembly.

5,6, Fixed and Sliding Half

▼ CAUTION
Do not tap on governor cup.

Screw puller into fixed half shaft about 13 mm (1/2 in). Raise drive pulley and hold it by the sliding half while knocking on puller head to disengage fixed half.

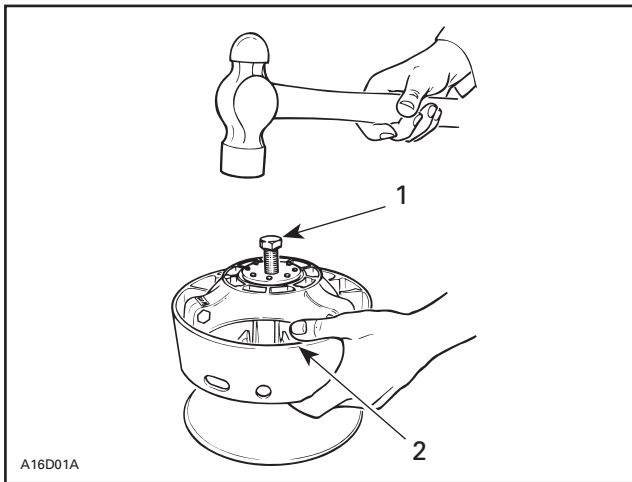

1. Puller
2. Holding sliding half

NOTE: No components marking is required before disassembling this drive pulley since it has factory mark and arrows as indexing reference.

25,29, Slider Shoe and Governor Cup

Carefully lift governor cup until slider shoes come at their highest position into guides.

Hold a slider shoe set then carefully lift its housing and remove them. Proceed the same way for other housings lifting one at a time.

32, Cushion Drive

▼ CAUTION
Do not disassemble cushion drive. Governor cup and cushion drive are factory balanced as an assembly.

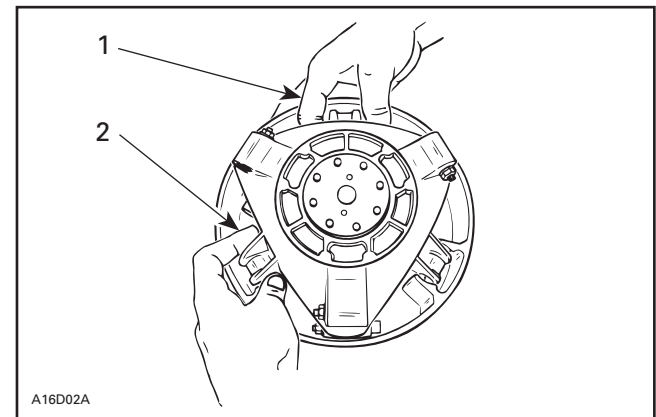

1. Hold slider shoes
2. Lift one housing at a time

NOTE: To ease disassembly, forks (P/N 529 0055 00) should be used to hold slider shoes prior to removing governor cup.

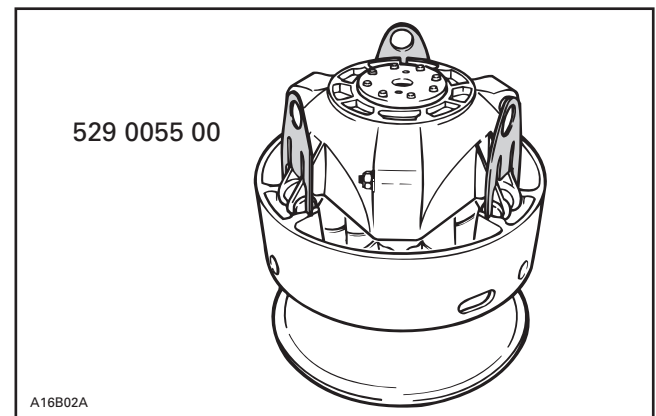

Section 04 TRANSMISSION

Sub-Section 03 (DRIVE PULLEY)

19, Spring Cover Ass'y

It is pushed by clutch spring pressure.

◆ WARNING

Clutch spring is very strong. Never attempt to remove spring cover without the recommended tools.

Use spring compressor (P/N 529 0151 00).

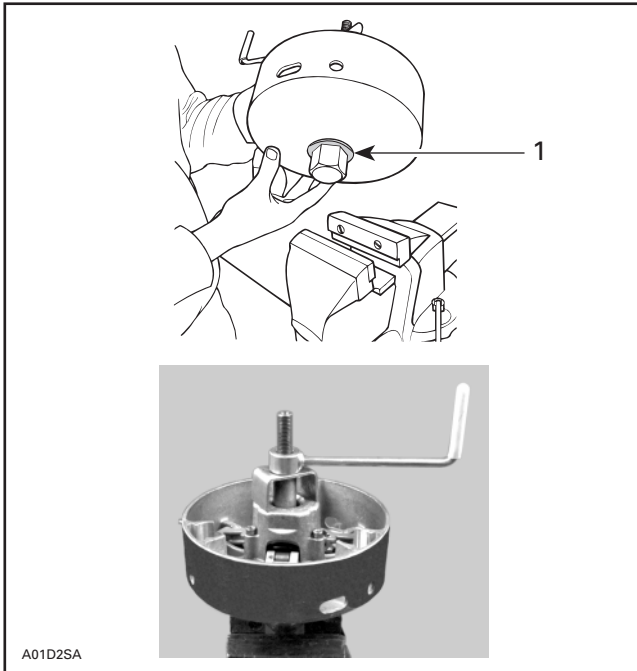

1. Washer must be here

Install tools as shown. Remove 3 Allen screws retaining spring cover then unscrew compressor.

CLEANING

5,6, Fixed and Sliding Half

Clean pulley faces and shaft with fine steel wool and dry cloth.

5, Fixed Half and Crankshaft End

Parts must be at room temperature before cleaning.

Using a paper towel with cleaning solvent (P/N 413 7082 00), clean crankshaft tapered end and the taper inside the fixed half of the drive pulley, crankshaft threads and retaining screw threads.

◆ WARNING

This procedure must be performed in a well ventilated area.

▼ CAUTION

Avoid contact between cleaner and crankshaft seal because damage may occur.

Remove all hardened oil deposits that have baked on crankshaft and pulley tapered surfaces with coarse or medium steel wool and/or sand paper no. 600.

▼ CAUTION

Do not use any other type of abrasive.

Reclean mounting surfaces with paper towel and cleaning solvent (P/N 413 7082 00).

Wipe off the mounting surfaces with a clean, dry paper towel.

▼ CAUTION

Mounting surfaces must be free of any oil, cleaner or towel residue.

7,20, Bushing

Only use petrol base cleaner when cleaning bushings.

▼ CAUTION

Do not use acetone to clean bushing.

INSPECTION

Drive pulley should be inspected annually.

16,17, Thrust Washer and Roller

Check roller for roundness of external diameter. Check thrust washer for thickness wear. Replace as required.

▼ CAUTION

Ensure rollers are in good condition. Replace as required.

9,12, Fitting Bolt Ass'y and Flanged Bushing

Check for wear, replace as required. When installing old style flanged bushing (made of black plastic), use a size "O" (letter) drill bit to ream inside diameter.

24,25, O-ring and Slider Shoe

Check if O-rings are cracked, cut or crushed. Replace as required.

Check slider shoes for wear. Replace if groove is not apparent on top.

5,29, Fixed Half and Governor Cup

Inspect splines and free play between both parts. Maximum free-play is 0.5 mm (.020 in) measured at calibration screw radius. Replace if required.

7,20, Sliding Half and Spring Cover Bushing

Visually inspect coating. Replace if worn.

Sliding Half Bushing Replacement

These bushings can be replaced using tools which are not available at time of printing.

Spring Cover Bushing Replacement

Under normal use there is no need to replace this bushing.

Use tools (P/N 529 0313 00 and 529 0312 00) to remove old bushing.

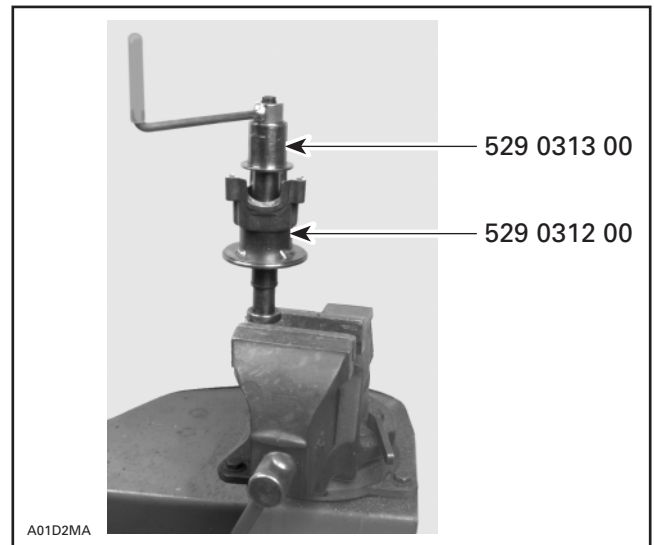

▼ CAUTION

Bushing must be bonded with retaining compound.

Apply retaining compound Loctite 648 outside of bushing then press it down to counterbore from outside end. Use spring compressor (P/N 529 0151 00) and appropriate tools.

▼ CAUTION

Insert bushing from outside (governor side) of spring cover.

Start driving bushing into spring cover.

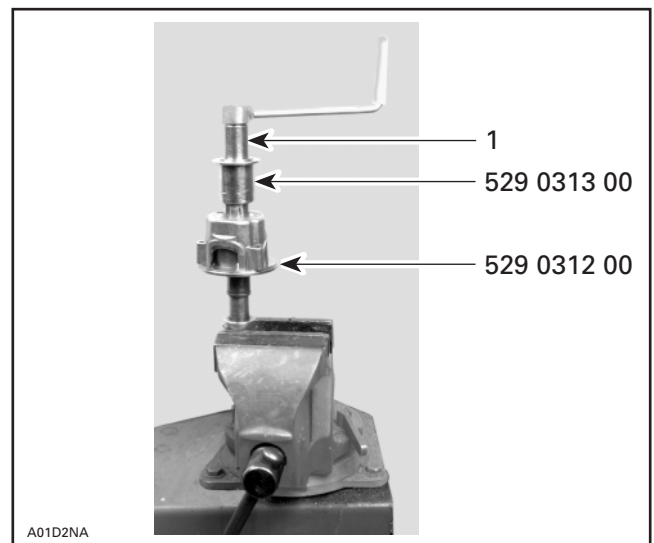

1. Note upper tool side

Section 04 TRANSMISSION

Sub-Section 03 (DRIVE PULLEY)

Press bushing.

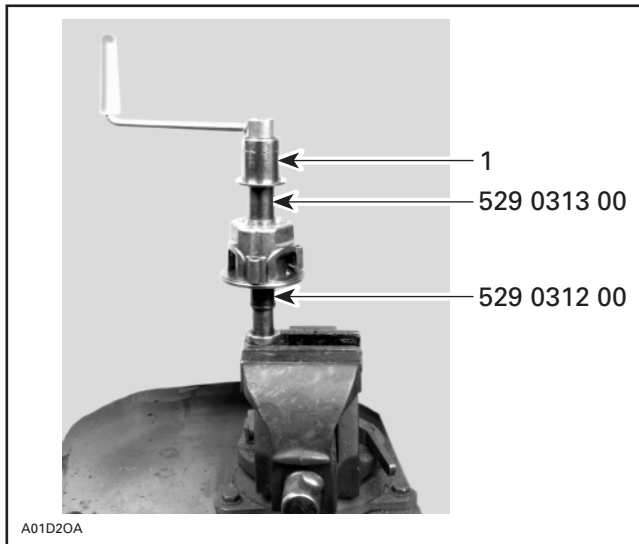

1. Note upper tool side.

ASSEMBLY

NOTE: This drive pulley is lubrication free. Do not lubricate any component.

1,2,3, Screw, Ring Gear and Loctite 271

Apply Loctite 271 (P/N 413 7029 00) on threads and then torque to 27 N•m (20 lbf•ft).

26,27,28, Calibration Screw, Washer and Locking Nut

When installing calibration screw, make sure to install washer as shown.

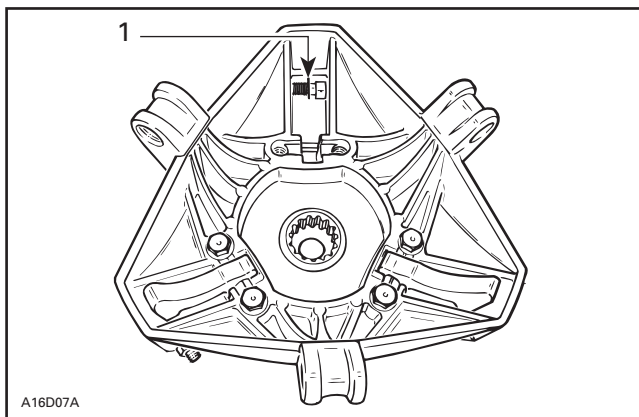

1. Washer

Torque locking nut to 10 N•m (89 lbf•in).

15, Pin

Always use the same type of pin as originally installed when servicing. Different types have different weights for calibration purpose. Refer to TECHNICAL DATA 09-03.

21,22,23, Ramp, Dowel Tube and Screw

Insert dowel tube from chamfered side. Make sure ramp is centered on dowel tube.

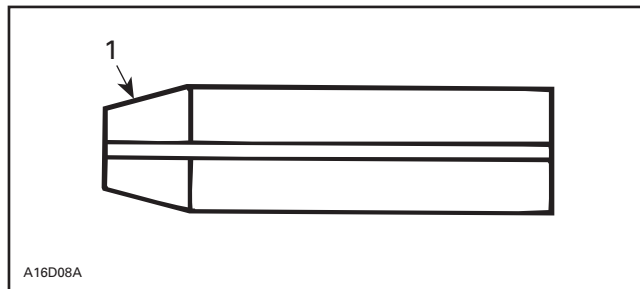

1. Chamfered side

Position dowel tube split at the illustrated angle.

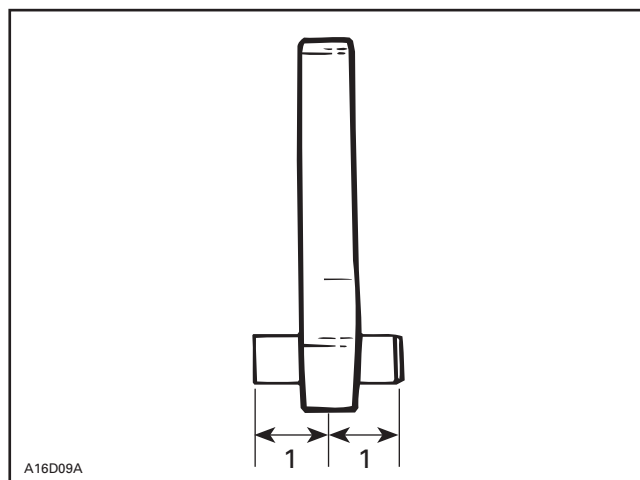
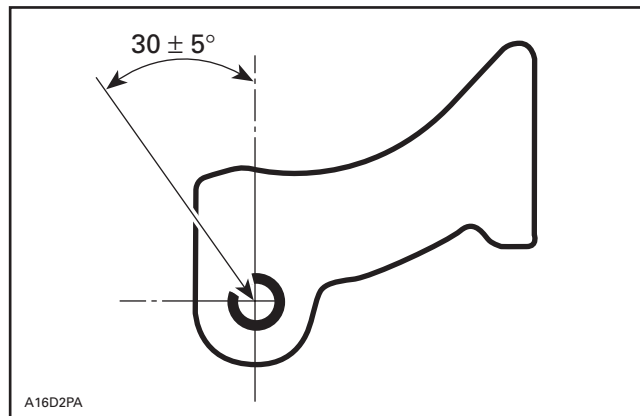

1. Equal distance

Torque screws to 10 N•m (89 lbf•in).

9,11,13,14, Screw, Lever Ass'y, Nut and Cotter Pin

Always install lever assemblies so that cotter pins are at the shown side. Besides install cotter pin head on top when lever is sat at bottom of sliding half. Bend cotter pin ends to sit perfectly against lever.

◆ WARNING

Whenever replacing centrifugal levers, always replace all 3 at the same time. Otherwise, clutch misbalancing will occur because of levers difference.

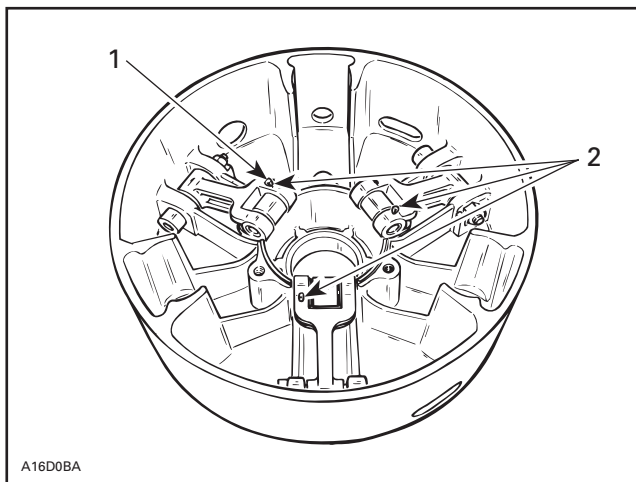

1. Head on top
2. All on the same side

▼ CAUTION

Lever assemblies must be installed so that cotter pins are on the same side.

Torque nuts to 12 N•m (106 lbf•in).

▼ CAUTION

Lever ass'y and rollers must move easily after installation.

5,6,18,19, Fixed Half, Sliding Half, Spring, Spring Cover and Screw

To install spring cover, use spring compressor (P/N 529 0151 00).

Assemble fixed and sliding halves. Note that fixed halves have different cone angle. Match cone angle with crankshaft.

Lift sliding half against spring cover and align spring cover arrow with sliding half mark.

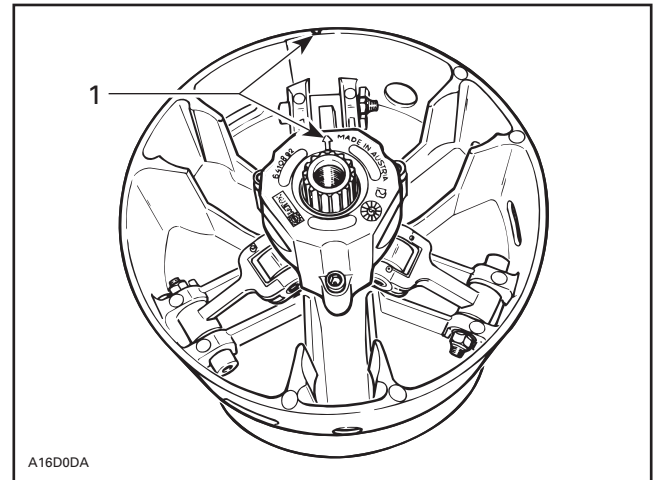

1. Align

Install and torque screws to 13 N•m (115 lbf•in).

6,25,29, Sliding Half, Slider Shoe and Governor Cup

To install governor cup, use following tool:

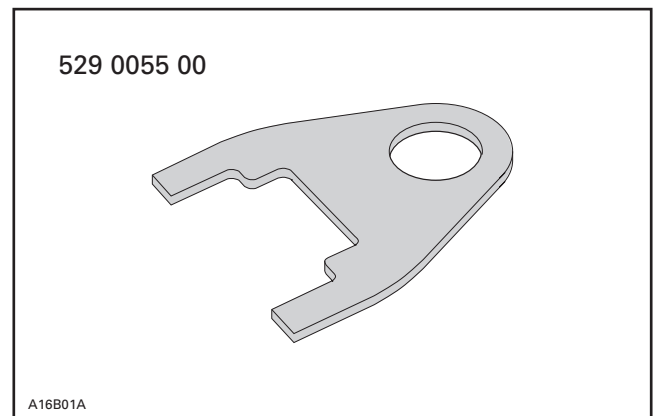

Insert spring and slider shoes into governor cup so that groove in each slider shoe is vertical to properly slide in guides.

▼ CAUTION

Make sure O-rings are installed on slider shoes and their grooves are positioned vertically.

Install fork (P/N 529 0055 00) into slider shoe grooves to maintain them for governor cup installation. Proceed on 3 set of slider shoes.

Section 04 TRANSMISSION

Sub-Section 03 (DRIVE PULLEY)

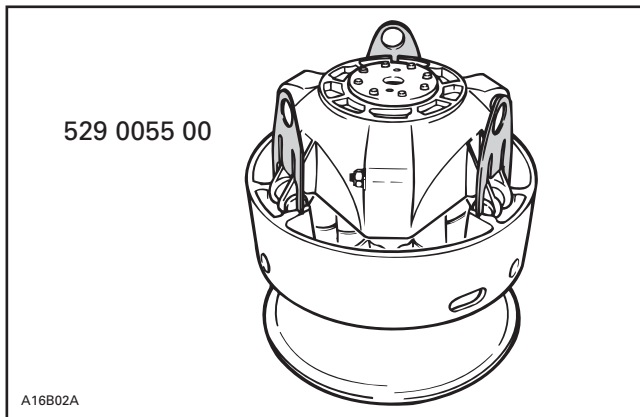

Make sure to align governor cup arrow with sliding half and fixed half mark.

NOTE: If fixed half has no mark, align governor cup mark with segment no. 1 of inner half. Segments are identified on engine side.

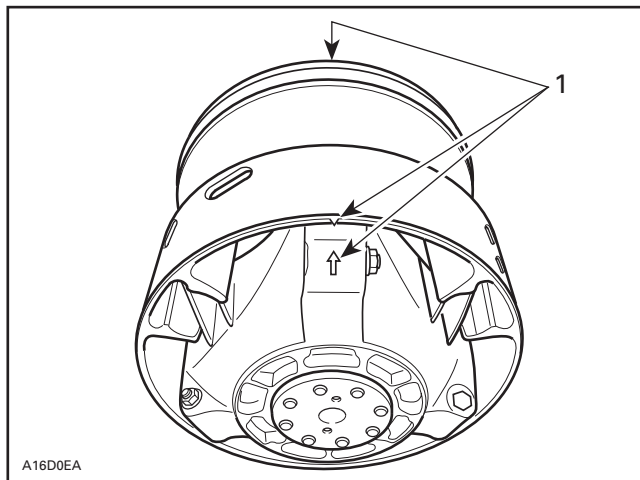

1. Align

Carefully slide governor cup into sliding half. Align mark of governor cup with mark of fixed half.

Remove forks and push governor cup so that its splines engage with fixed half shaft splines.

▼ CAUTION

Make sure splines of both parts are fully engaged.

INSTALLATION

◆ WARNING

Do not apply anti-seize or any lubricant on crankshaft and drive pulley tapers.

◆ WARNING

Never use any type of impact wrench at drive pulley removal and installation.

Clean mounting surfaces as described in CLEANING above.

Drive Pulley Ass'y

The installation procedure must be strictly adhered to as follows.

Install drive pulley on crankshaft extension.

Install conical washer with its concave side towards drive pulley then install screw.

◆ WARNING

Never substitute lock washer and/or screw with jobber ones. Always use Bombardier genuine parts for this particular case.

Use clutch holder. See removal procedure.

Torque screw to 90 to 100 N•m (66 to 74 lbf•ft).

Install drive belt and belt guard.

Raise and block the rear of the vehicle and support it with a mechanical stand.

◆ WARNING

Ensure that the track is free of particles which could be thrown out while track is rotating. Keep hands, tools, feet and clothing clear of track. Ensure nobody is standing near the vehicle.

Accelerate the vehicle at low speed (maximum 30 km/h (20 MPH)) and apply the brake, repeat 5 times.

Recheck the torque of 90 to 100 N•m (66 to 74 lbf•ft).

◆ WARNING

After 10 hours of operation the transmission system of the vehicle must be inspected to ensure the retaining screw is properly torqued.

DRIVE PULLEY ADJUSTMENT

The drive pulley is factory calibrated to transmit maximum engine power at a predefined RPM. Factors such as ambient temperature, altitude or surface condition may vary this critical engine RPM thus affecting snowmobile efficiency.

This adjustable drive pulley allows setting maximum engine RPM in the vehicle to maintain maximum power.

Calibration screws should be adjusted so that actual maximum engine RPM in vehicle matches with the maximum horsepower RPM given in TECHNICAL DATA 09-02.

NOTE: Use precision digital tachometer for engine RPM adjustment.

NOTE: The adjustment has an effect on high RPM only.

To adjust, modify ramp end position by turning calibration screws.

26,28,29, Calibration Screw, Locking Nut and Governor Cup

Calibration screw has a notch on top of its head.

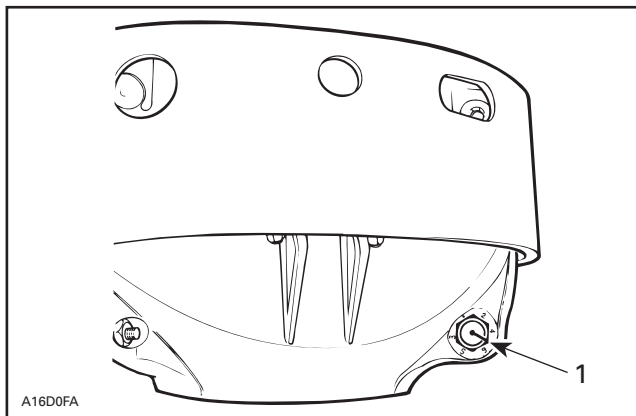

1. Notch

Governor cup has 6 positions numbered 2 to 6. Note that in position 1 there is no stamped number (due to its location on casting).

See TECHNICAL DATA 09-03 for original setting.

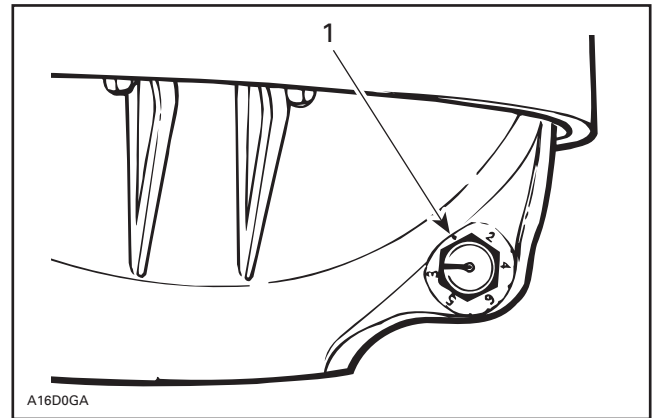

1. Position 1 (not numbered)

Each number modifies maximum engine RPM by about 200 RPM.

Lower numbers decrease engine RPM in steps of 200 RPM and higher numbers increase it in steps of 200 RPM.

Example:

Calibration screw is set at position 3 and is changed to position 5. So maximum engine RPM is increased by about 400 RPM.

To Adjust:

Just loosen locking nut enough to pull calibration screw **partially** out and adjust to desired position. Do not completely remove the locking nut. Torque locking nuts to 10 N•m (89 lbf•in).

▼ CAUTION

Do not completely remove calibration screw or its inside washer will fall off.

▼ CAUTION

Always adjust all 3 calibration screws and make sure they are all set at the same number.

Section 04 TRANSMISSION

Sub-Section 03 (DRIVE PULLEY)

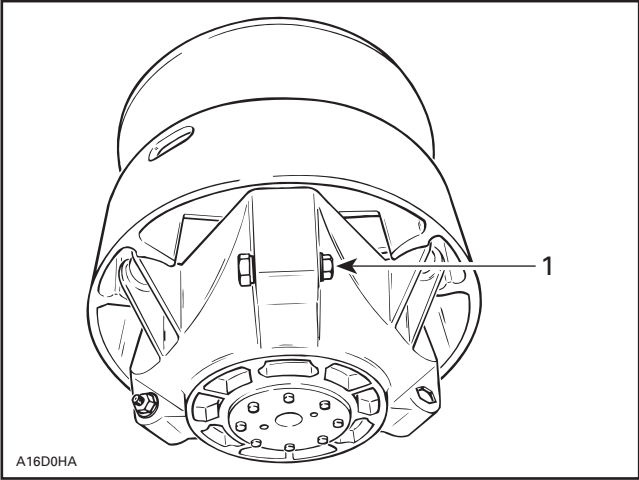

A16D0HA

1. Loosen just enough to permit rotating of calibration screw

DRIVEN PULLEY

F-Series

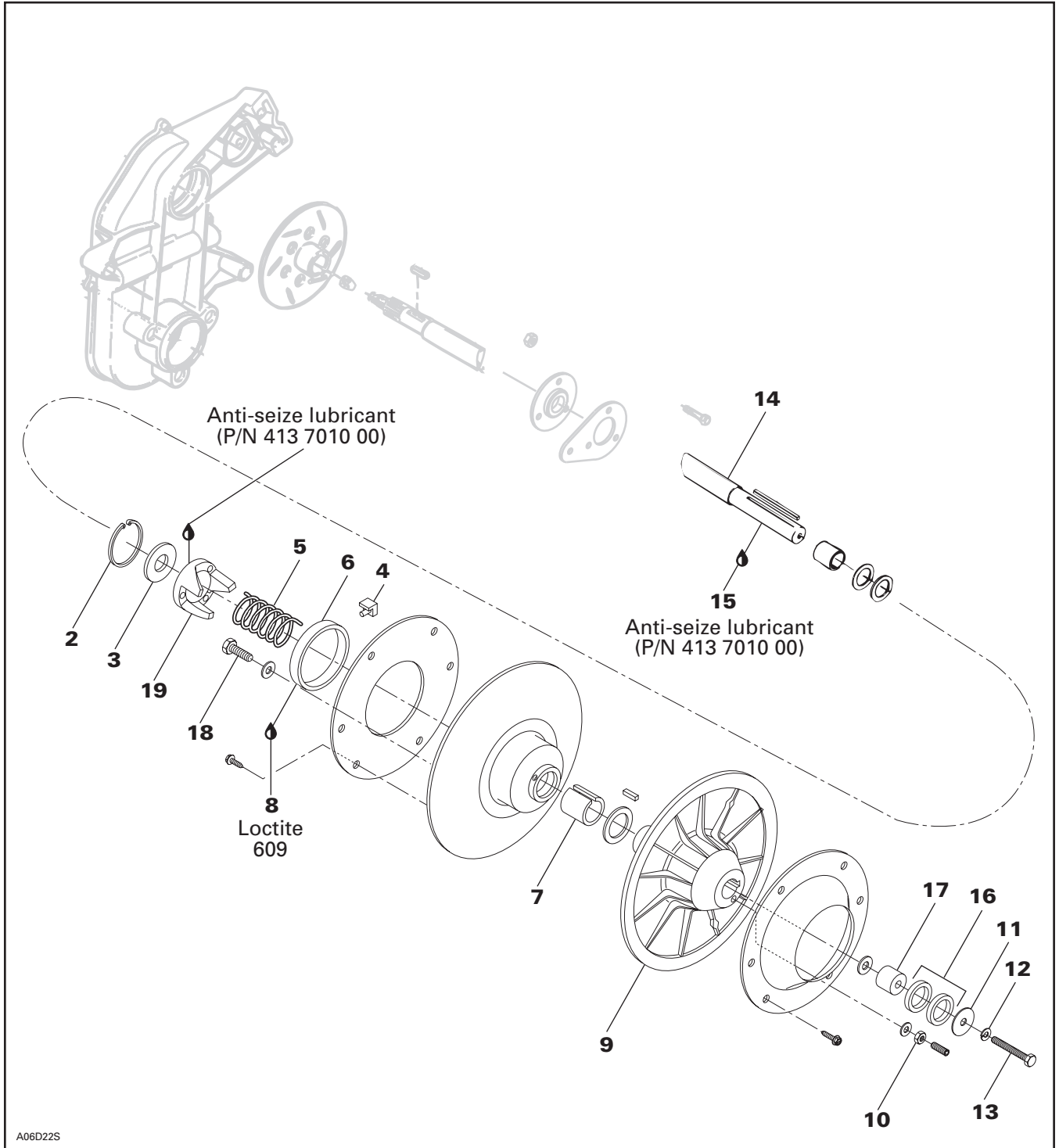

Section 04 TRANSMISSION

Sub-Section 04 (DRIVEN PULLEY)

REMOVAL

Remove belt guard and drive belt from vehicle.

Remove the cap screw **no. 13**, lock washer **no. 12**, washer **no. 11**, extension **no. 17** and shims **no. 16** then pull the driven pulley from the countershaft.

14, Countershaft

Should countershaft **no. 14** removal be required, refer to BRAKE 04-06 then look for **Countershaft and Brake Disc Removal**.

DISASSEMBLY

Use spring compressor (P/N 529 0151 00).

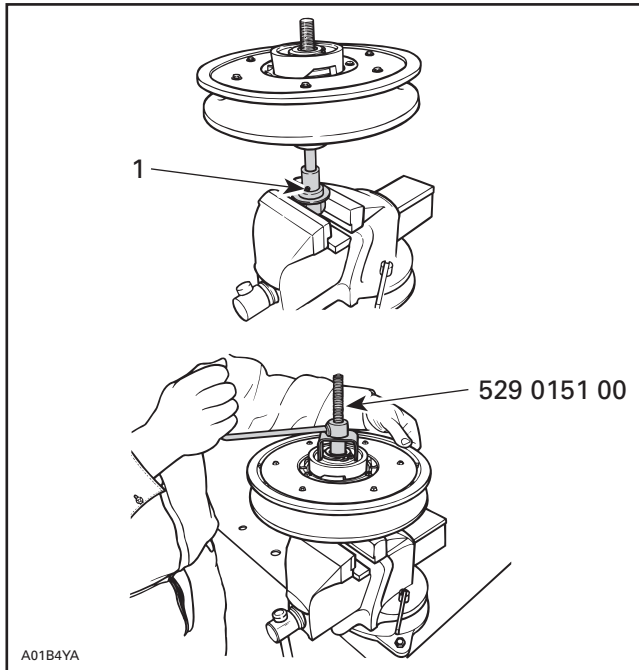

TYPICAL

1. Insert this pin in keyway

Remove snap ring **no. 2** and washer **no. 3** to disassemble the outer cam and the 2 pulley halves.

◆ WARNING

Driven pulley cam is spring loaded, use above mentioned tool.

CLEANING

6,7, Large Bushing and Small Bushing

During break-in period (about 10 hours of use), teflon from bushing moves to cam or shaft surface. A teflon over teflon running condition occurs, leading to low friction. So it is normal to see gray teflon deposit on cam or shaft. Do not remove that deposit, it is not dust.

When a dust deposit has to be removed from the cam or the shaft, use dry cloth to avoid removing transferred teflon.

Pulley Half Cleaning

Use Loctite Safety Solvent (P/N 413 7082 00).

INSPECTION

6,7, Bushings

Check for cracks, scratch and for free movement when assembled to fixed half.

Using a dial bore gauge measure bushing diameter. Measuring point must be at least 5 mm (1/4 in) from bushing edge.



Replace bushing(s) if worn more than specified.

DRIVEN PULLEY BUSHING WEAR LIMIT mm (in)	
Small bushing	38.30 (1.508)
Large bushing	89.15 (3.510)

4, Slider Shoe

Check cam slider shoes for wear. Replace when inside edge of cam slider shoe slope base is worn to 1 mm (.039 in) or less.

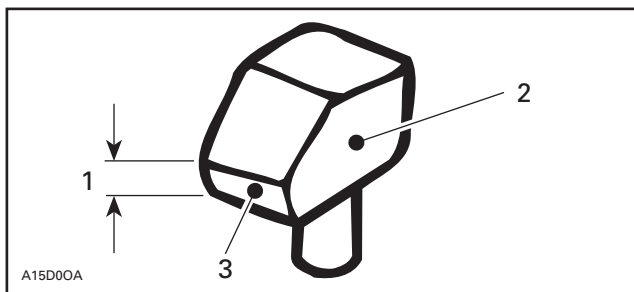

1. Measure thickness of slope base here
2. Sliding pulley side
3. Slope base

Bushing Replacement

Large Bushing

Remove Allen screws if applicable. Heat to break Loctite bond.

Remove all 3 slider shoes.



Install support plate (P/N 529 0311 03) inside sliding half.

Place puller (P/N 529 0311 02) below bushing.

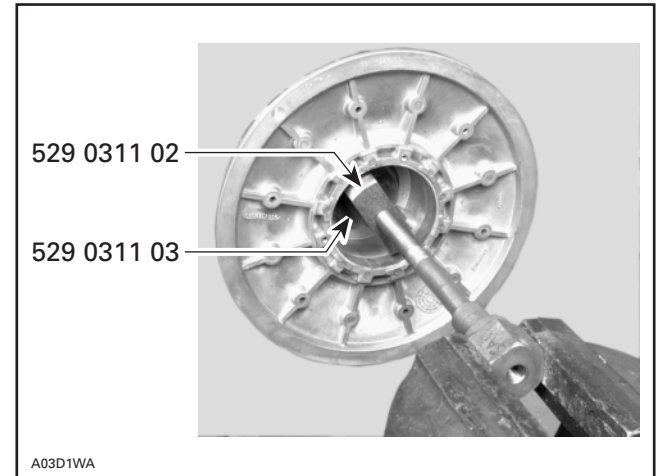

Mount puller screw head in a vise.

Turn pulley half by hand to extract old bushing.

Before bushing installation, file sliding half bore to remove burrs from crimping areas.

Coat bushing outside diameter with Loctite 609 (P/N 413 7031 00). Place new bushing on sliding half and slightly tap to engage squarely the bushing in the sliding. Use tools (P/N 529 0312 00 and 529 0313 00) to install bushing.

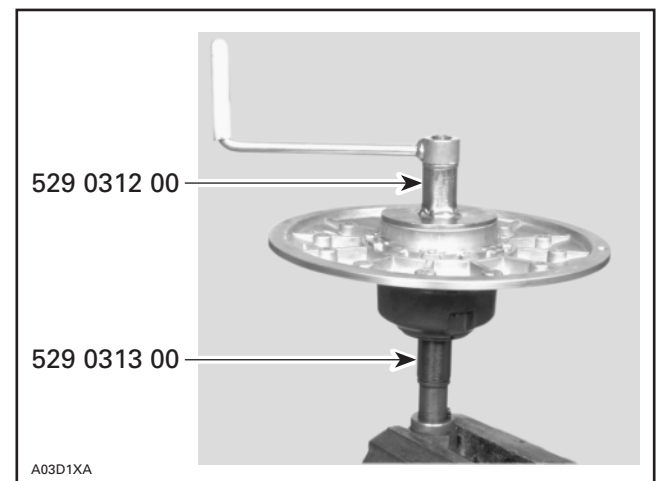

Install 3 Allen screws **no. 18** and washers supplied with the new bushing.

Section 04 TRANSMISSION

Sub-Section 04 (DRIVEN PULLEY)

Small Bushing

NOTE: Following procedure can be done with a press using the same tools.

Install puller in a vise.

Heat bushing area.

Turn puller handle and sliding half at once to extract the bushing.

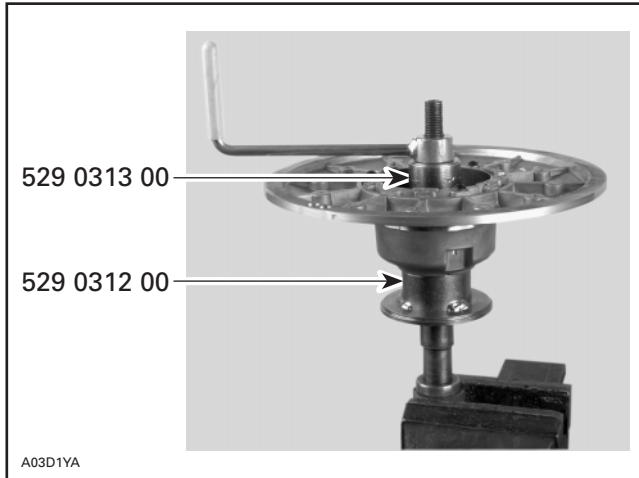

IMPORTANT: Large bushing retaining screws and washers must be removed before small bushing installation.

Coat bushing outside diameter with Loctite 609 (P/N 413 7031 00).

Install bushing as following photo.

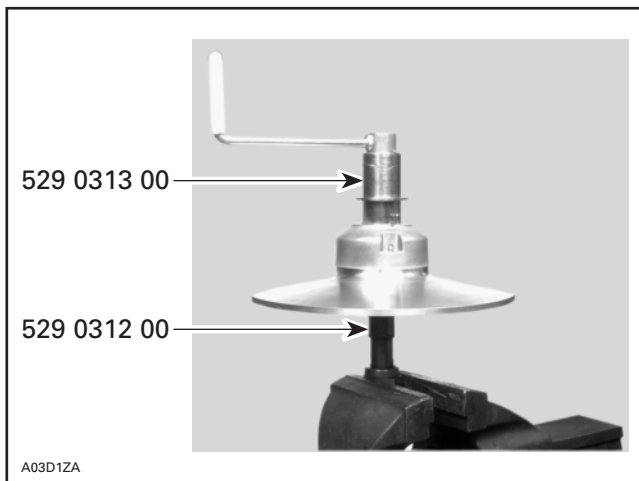

ASSEMBLY

4, Cam Slider Shoe

When replacing slider shoes, always install a new set (3 shoes) to maintain equal pressure on the cam.

Assemble driven pulley components by reversing the disassembly procedure.

19, Cam

Coat cam interior with anti-seize lubricant.

INSTALLATION

14,15, Countershaft and Anti-seize Lubricant

▼ CAUTION

Always apply anti-seize lubricant (P/N 413 7010 00) on the countershaft before final pulley installation.

Should installation procedure be required, refer to BRAKE 04-06 then look for **Brake Disc and Countershaft Bearing Adjustment**.

Reinstall the pulley on the countershaft by reversing the removal procedure.

Check end play of driven pulley on countershaft by pushing pulley towards outer housing so that the inner shims (P/N 504 1082 00) contact it. Measure end play at the mounting screw end between shim(s) and pulley. See illustration.

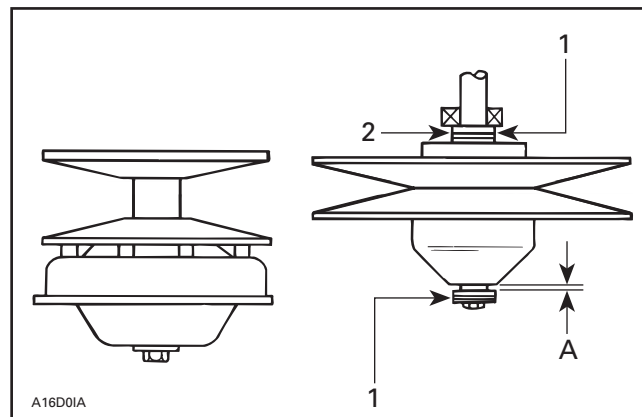

TYPICAL — TOP VIEW

1. Shim (P/N 504 1082 00) (as required)
2. Contact
- A. 0 to 1 mm (0 to 3/64 in)

13, Pulley Retaining Screw

Torque to 25 N•m (18 lbf•ft).

ADJUSTMENT

Refer to PULLEY DISTANCE AND ALIGNMENT 04-05 to adjust pulley distance. Adjust drive belt height in driven pulley to obtain specified belt deflection.

5, Spring

General

It is usual to experience spring setting during breaking period of a new spring. The factory spring preload is slightly higher to compensate for spring setting. Specifications in TECHNICAL DATA 09-03 are applicable after break-in period (about 10 hours of use.)

Spring Torsional Pre-Load

To check spring pre-load adjustment, use spring scale hook (P/N 529 0065 00) and a spring scale.

Remove drive belt.

Install the hook on the sliding half. Preventing fixed half from turning, pull sliding half with the spring scale perpendicularly with pulley axle.

Take 1st measurement when sliding half begins to turn. Rotate sliding half to 10 mm (3/8 in) of rotation. Hold fish scale at this position. Slowly release tension from fish scale and take 2nd measurement when sliding half begins to return. Spring pre-load is the average measurement between these 2.

$$\frac{1^{\text{st}} \text{ measurement (when opening)} + 2^{\text{nd}} \text{ measurement (when closing)}}{2} = \text{Spring pre-load}$$

$$\text{Example: } \frac{3.8 \text{ kg (8.4 lb)} + 3.4 \text{ kg (7.5 lb)}}{2} = 3.6 \text{ kg (8 lb)} \text{ Actual spring pre-load}$$

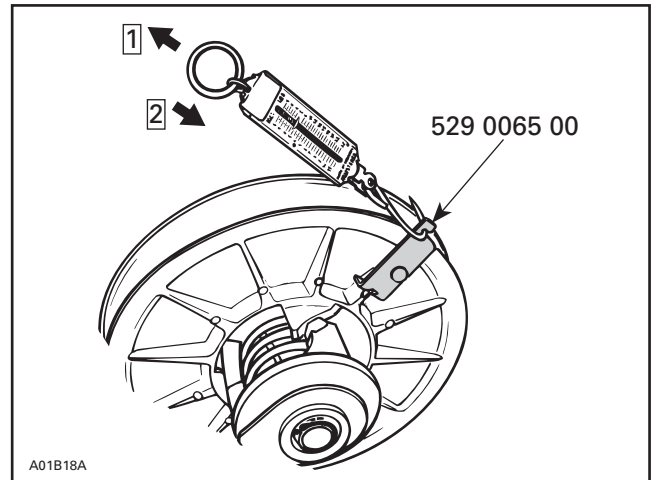

TYPICAL

Step 1: 1st measurement

Step 2: 2nd measurement

To adjust spring pre-load, relocate spring end in cam, moving it clockwise to increase the pre-load and counterclockwise to decrease it. Refer to TECHNICAL DATA 09-03.

NOTE: If spring pre-load can not be adjusted, try to relocate the other end of spring in sliding pulley (holes A, B, C).

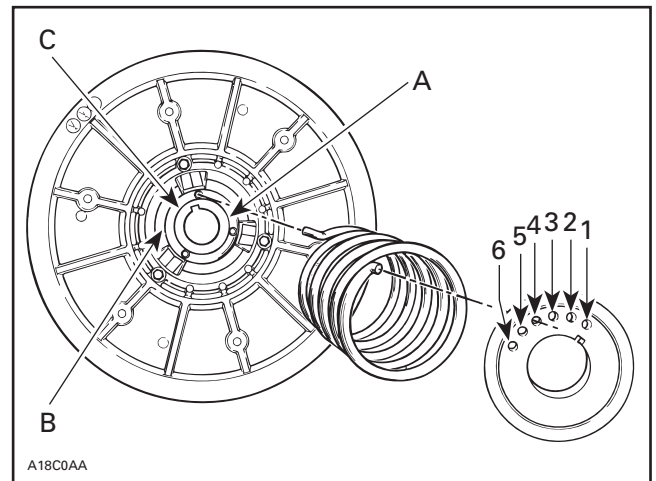

Letters and numbers shown in illustration are actual letters and numbers embossed on parts

NOTE: Always recheck torsional pre-load after adjusting.

Section 04 TRANSMISSION

Sub-Section 04 (DRIVEN PULLEY)

Pulley Alignment and Drive Belt Deflection

Refer to PULLEY DISTANCE AND ALIGNMENT 04-05 and DRIVE BELT 04-02 to perform adjustments.



CAUTION

Drive belt and pulley adjustments must always be checked whenever pulleys have been removed, replaced or disassembled.

3, Outer Cam

Make sure to install proper cam. Refer to TECHNICAL DATA 09-03.

Cam angle is identified on cam.

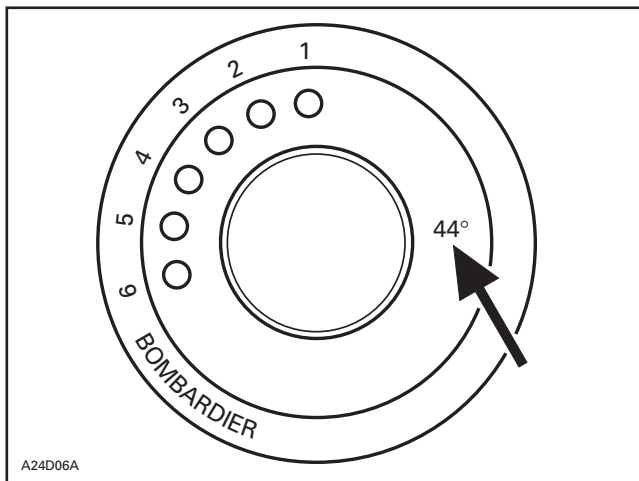

NOTE: For high altitude regions, the *High Altitude Technical Data Booklet* (P/N 484 0648 00 and 484 0545 00 for binder) gives information about calibration according to altitude.

PULLEY DISTANCE AND ALIGNMENT

GENERAL

The pulley distance we will refer to in this section, is the space separating the drive and driven pulley outside diameters (Z measurement).

This basic distance is provided as an assembly guide and indicates the dimensions between which satisfactory belt deflection will be obtained.

Both pulley distance adjustment and pulley alignment must be carried out to ensure the highest efficiency of the transmission system. Furthermore, optimum drive belt operation and minimal wear will be obtained only with proper pulley alignment.

▼ CAUTION

Before checking pulley adjustment, the rear suspension must be mounted on the vehicle and track tension/alignment must be done. Always check pulley adjustment after suspension is adjusted.

◆ WARNING

Failure to correctly perform pulley alignment may cause the vehicle to creep forward at idle.

All Pulley Alignment Specifications Refer to:

X = Distance between straight bar and drive pulley fixed half edge, **measured between pulleys.**

Y = Distance between straight bar and drive pulley fixed half edge, **measured at the end of straight bar.**

Z = Distance between outside diameter of pulleys.

GENERAL PROCEDURE

Remove belt guard and drive belt.

By turning and pushing the sliding half, open the driven pulley. Insert a straight bar 9.5 mm (.375 in) square, 48 cm (19 in) long or the proper alignment template into the opened driven pulley.

Measuring Procedure

Using Straight Bar:

Always measure distances X and Y from the farther straight bar side (including its thickness to the fixed half edge.)

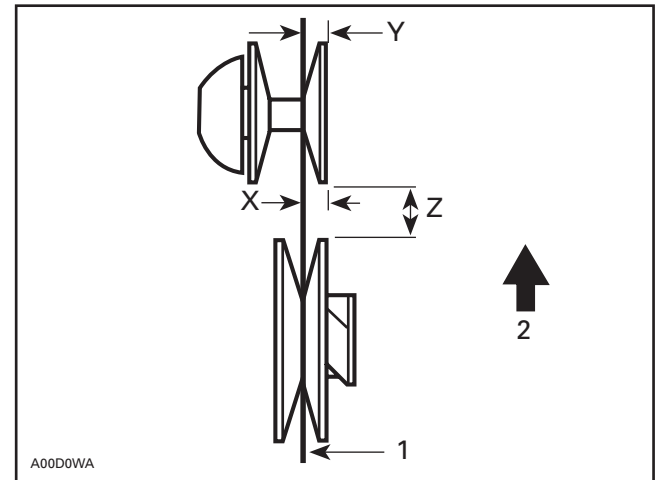

1. Straight bar
2. Front of vehicle

The distance Y **must** exceed distance X to compensate for the twist due to the engine torque.

Nominal Value Procedure and Quick Alignment and Distance Check

Alignment template tabs must fully contact fixed half of drive pulley.

Pulley distance is correct when tab contacts both pulley halves.

Refer to below chart for proper alignment template.

Section 04 TRANSMISSION

Sub-Section 05 (PULLEY DISTANCE AND ALIGNMENT)

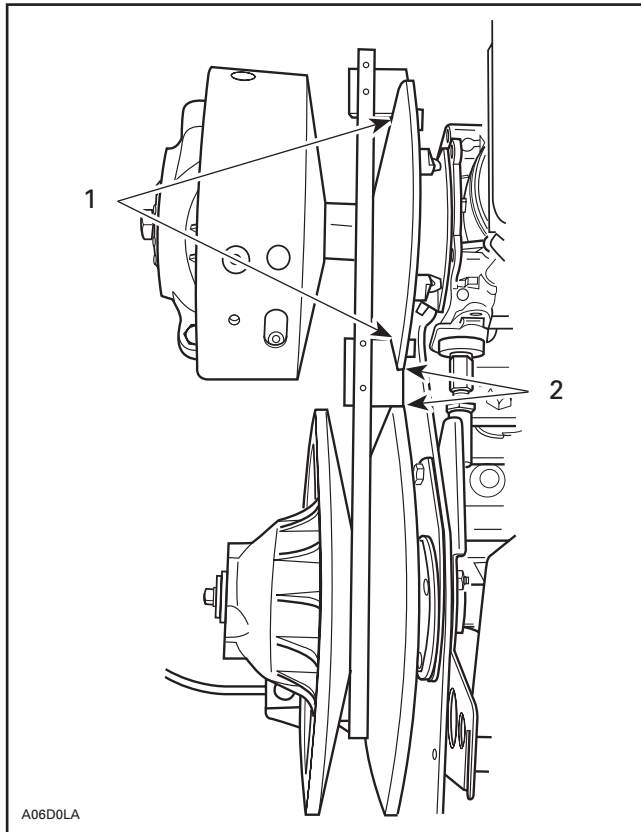

Drive Belt Deflection

NOTE: When pulley distance and alignment are adjusted to specifications, refer to DRIVE BELT 04-02 to adjust drive belt deflection.

▼ CAUTION

This section deals mainly with adjustment procedures. For complete assembly requirements, refer to the proper ENGINE or TRANSMISSION installation section.

TYPICAL

1. Contact (alignment)
2. Contact (distance)

PULLEY ALIGNMENT AND DISTANCE SPECIFICATIONS CHART

MODEL	PULLEY DISTANCE	OFFSET		ALIGNMENT TEMPLATE ① P/N
	Z	X	Y-X	
	+ 0, - 1 mm (+ 0, - 0.040 in)	± 0.50 mm (0.020 in)	± 0.5 mm (0.020 in)	
All	16.5 (0.650)	35.0 (1.380)	1.5 (0.060)	529 0267 00

- ① Alignment templates have been made according to pulley alignment nominal values. However, they do not take into account allowed tolerances for alignment specifications. They are used as GO/NO GO gauges for quick alignment and pulley distance check and as templates to reach alignment nominal values.

Section 04 TRANSMISSION

Sub-Section 05 (PULLEY DISTANCE AND ALIGNMENT)

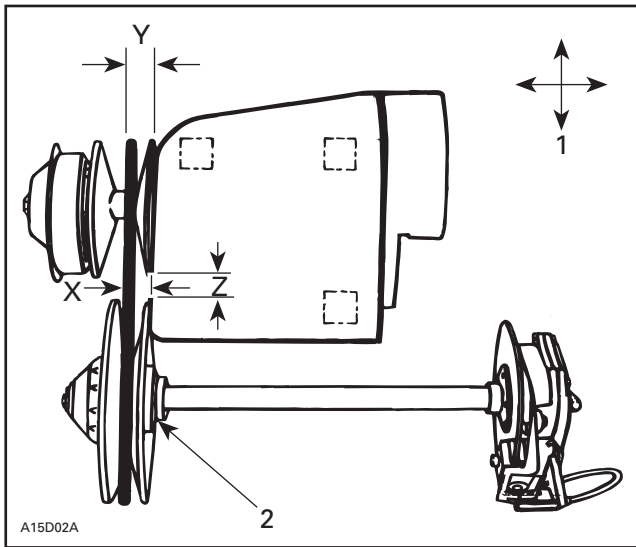

TYPICAL

1. Engine movement
2. Contact

NOTE: Prior to performing pulley adjustment, loosen torque rod nut to allow engine movement. Engine supports have tendency to stick to frame, work engine loose prior to aligning.

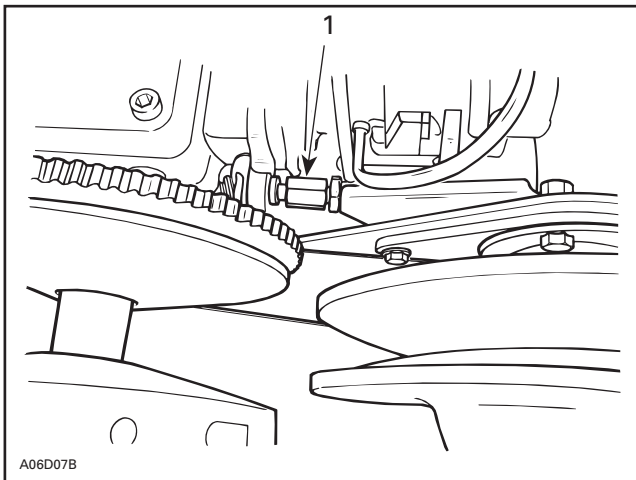

1. Loosen

Pulley Distance Adjustment Method

Engine Movement

The engine support has slotted mounting holes. Move engine to obtain specified distance between pulleys.

Pulley Alignment Method

Driven Pulley Movement

When engine slotted mounting holes do not allow to set proper pulley offset X, adjust with shims (P/N 504 1082 00) between pulley and counter-shaft bearing support (pulley pushed toward brake disc).

Engine Movement

Loosen the 4 bolts retaining engine support to the frame. Position engine to obtain the specified alignment.

NOTE: After alignment, adjust torque rod so it slightly contacts stopper plate. Do not over tighten, it will disalign pulleys.

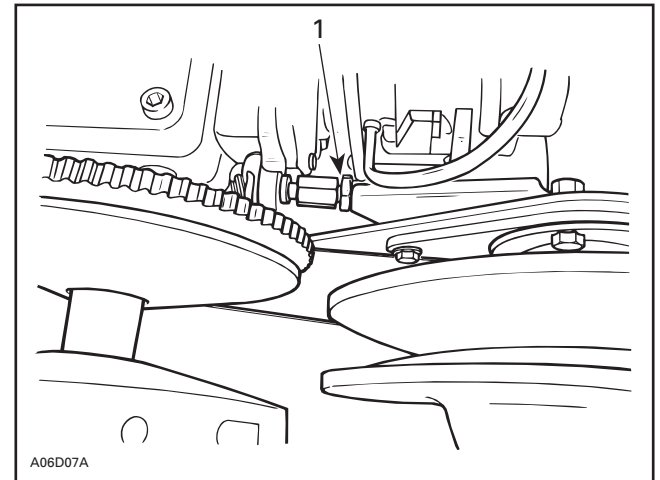

1. Retighten

BRAKE

HYDRAULIC DISC BRAKE

F-Series

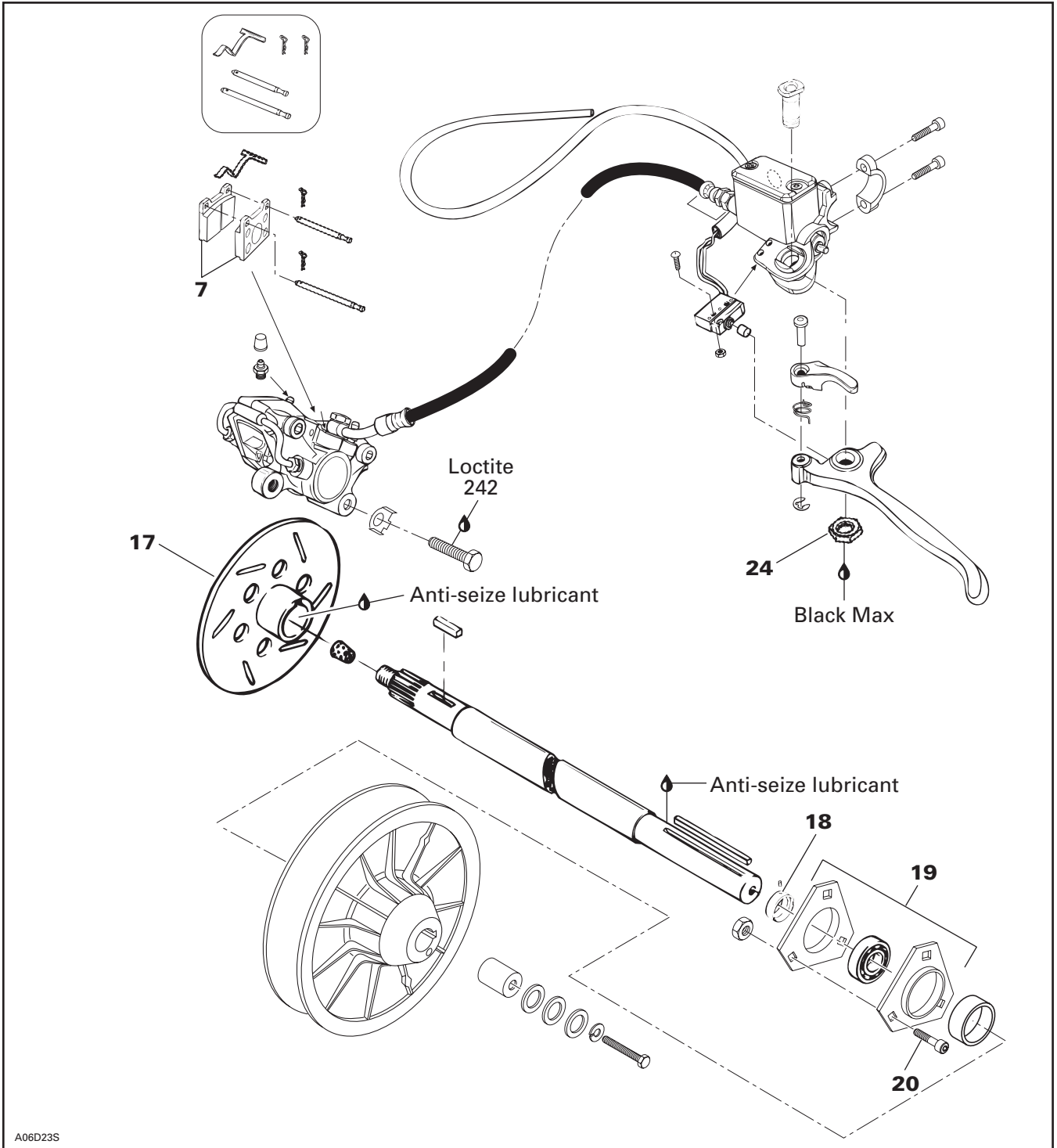

Section 04 TRANSMISSION

Sub-Section 06 (BRAKE)

REMOVAL

BRAKE DISC REMOVAL

Brake disc can be withdraw without removing caliper. Proceed as follows:

- Remove belt guard, belt and driven pulley.
- Remove air silencers.
- Unbolt bearing support **no. 19** from chassis.
- Open chaincase and remove upper sprocket.
- Pull countershaft toward driven pulley side to free from chaincase and disc.
- Remove disc.

COUNTERSHAFT REMOVAL

Proceed the same as for brake disc removal but unlock bearing collar **no. 18** on driven pulley side.

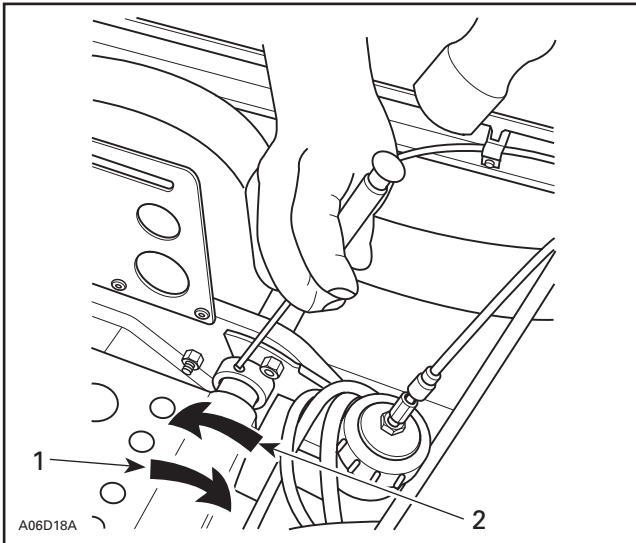

1. Lock
2. Unlock

Unbolt bearing support **no. 19** then install screw on countershaft.

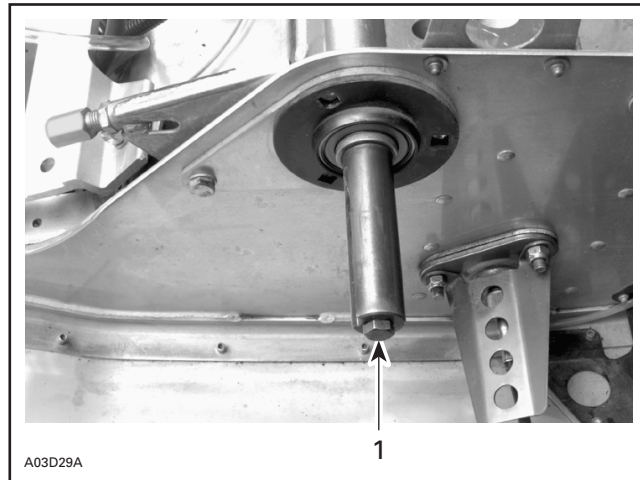

1. Screw

Pull bearing to driven pulley side out of countershaft, using remover (P/N 529 0301 00). Begin with only the remover then add a spacer of different width as the bearing comes out.

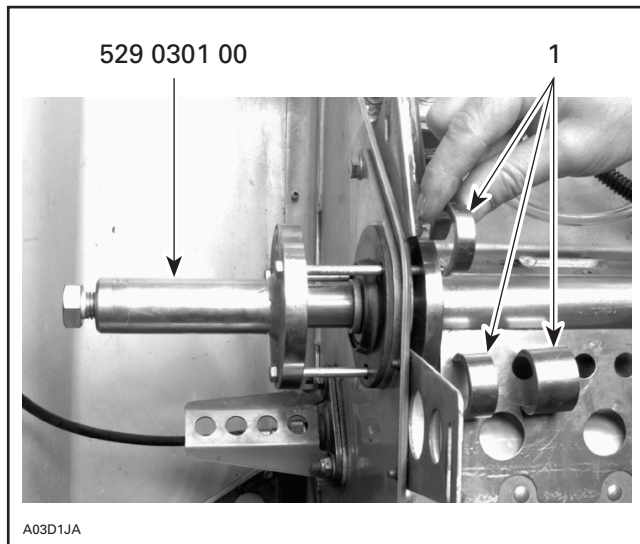

1. Spacers

To install bearing on countershaft, use installer (P/N 529 0302 00) and spacer(s) from remover as required.

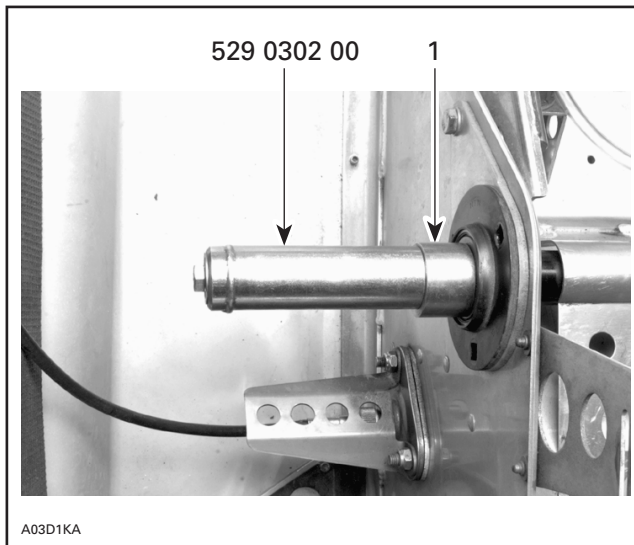

1. Spacer

DISASSEMBLY

Only brake pads are available as spare parts. If caliper or master cylinder are damaged, replace each of them as an assembly.

CLEANING

Clean all metal components in a general purpose solvent. Thoroughly dry all components before assembling.

<p>▼ CAUTION</p>
<p>Do not clean brake pads in solvent. Soiled brake pads must be replaced by new ones.</p>

INSPECTION

7, Brake Pad

Brake pads must be replaced when lining is 1 mm (1/32 in) thick or less.

<p>▼ CAUTION</p>
<p>Brake pads must always be replaced in pairs.</p>

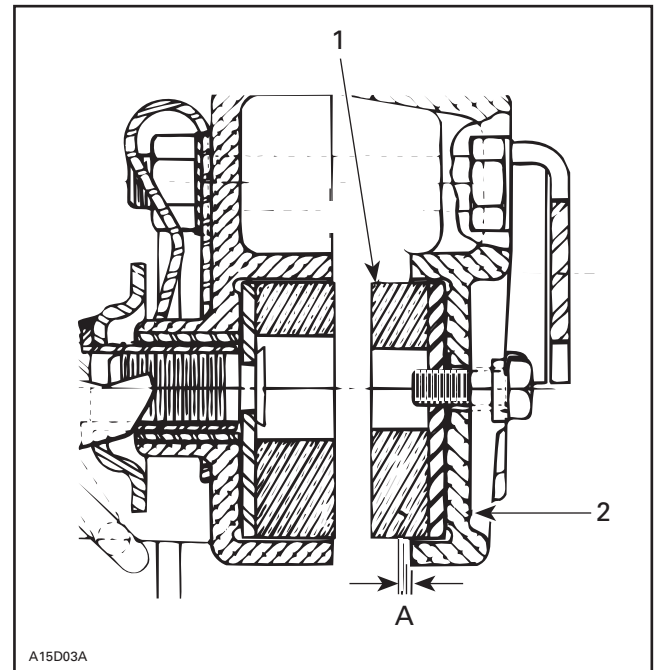

TYPICAL

- 1. Fixed pad
- 2. Inner caliper
- A. 1 mm (1/32 in) minimum

17, Brake Disc

Check for scoring, cracking or bending, replace as required.

<p>▼ CAUTION</p>
<p>Brake disc should never be machined.</p>

ASSEMBLY

24, Brake Lever Lock Nut

<p>◆ WARNING</p>
<p>Always install a new nut when servicing.</p>

Tighten nut to 3.0 N•m (27 lbf•in). Check free movement of brake lever.

Apply Loctite Black Max Gel (Loctite item no. 18398) over nut and on bolt threads.

Section 04 TRANSMISSION

Sub-Section 06 (BRAKE)

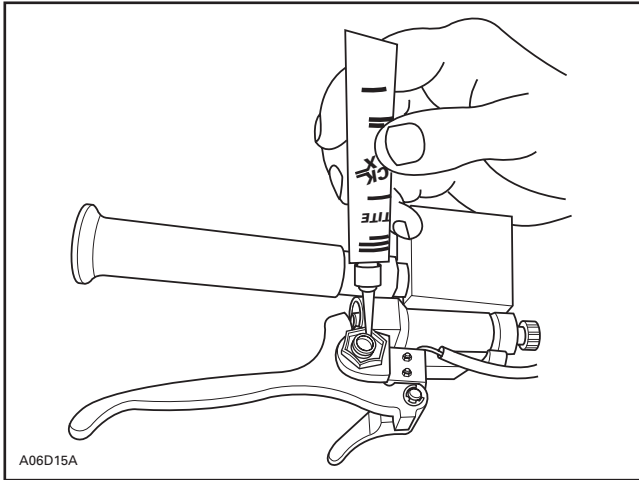

INSTALLATION

To install brake, reverse removal procedure paying attention to the following.



WARNING

Avoid getting oil on brake pads.

7, Brake Pad

After brake pads installation, brake disc must be centered in caliper. Apply brake then check for proper brake disc positioning.

Push on appropriate caliper piston in order to move pad inward allowing proper brake disc positioning.

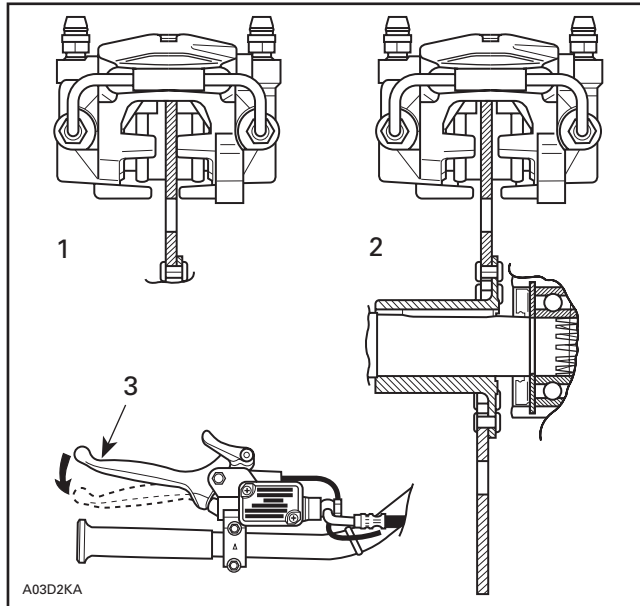

1. Brake disc not centered
2. Brake disc centered
3. Apply brake before checking

Apply brake then recheck.

17, Brake Disc

Apply anti-seize lubricant (P/N 413 7010 00) on shaft.

The disc hub exceeds the disc more from one side than from the other. Install disc with the longer exceeding portion toward driven pulley.

ADJUSTMENT

Countershaft Bearing

Insert countershaft (with brake disc) from chaincase side through countershaft support (driven pulley side), then insert into chaincase.

Install countershaft bearing **no. 19** and ensure that countershaft is properly aligned, then tighten 3 retaining screws.

NOTE: A misaligned countershaft will result in difficulty to center the bearing in its support.

Refer to DRIVE AXLE 06-03 then look **Chaincase Perpendicularity Adjustment**.

Torque castellated nut of upper sprocket to 53 N•m (39 lbf•ft).



CAUTION

Upper sprocket castellated nut must be tightened **before** adjusting bearing collar.

Slide collar **no. 18** towards bearing and turn, by hand, to engage the eccentric. This should require about a quarter turn.

Turn collar in direction of countershaft rotation until collar and inner race lock together.

Insert a punch into collar hole and strike sharply in the same direction to lock firmly.

Apply Loctite 242 (P/N 413 7030 00) on set screw threads, then tighten.

Close chaincase referring to CHAINCASE 04-07.

Brake Light

There is no adjustment on these models. Check that switch is securely installed.

BLEEDING

Change brake fluid once a year.

Bleed brake system as follows:

Keep sufficient DOT 4 (DOT 3 for normal use) brake fluid in reservoir at all times.

▼ CAUTION

Use only DOT 4 brake fluid for heavy duty or racing applications.

Install a hose on left side bleeder. Route this hose to a container.

Pump a few times brake lever and while holding brake lever depressed, open bleeder and check for air to escape.

Repeat with the same bleeder until no air appears in hose.

Proceed the same way with the right side bleeder.

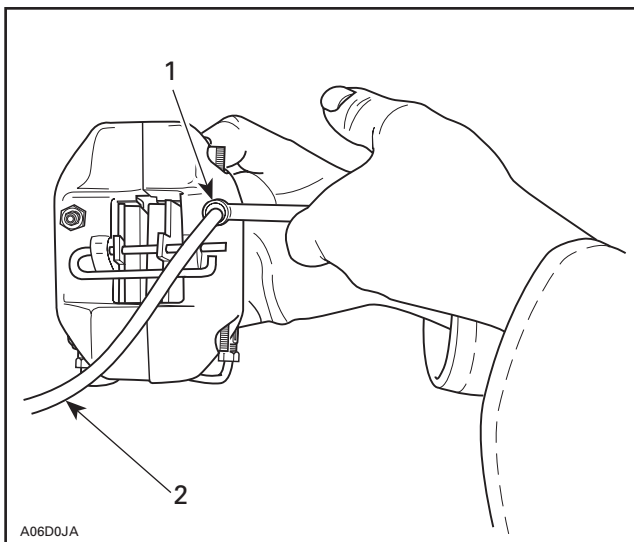

1. Open bleeder
2. Clear hose to catch used brake fluid

CHAINCASE

F-Series

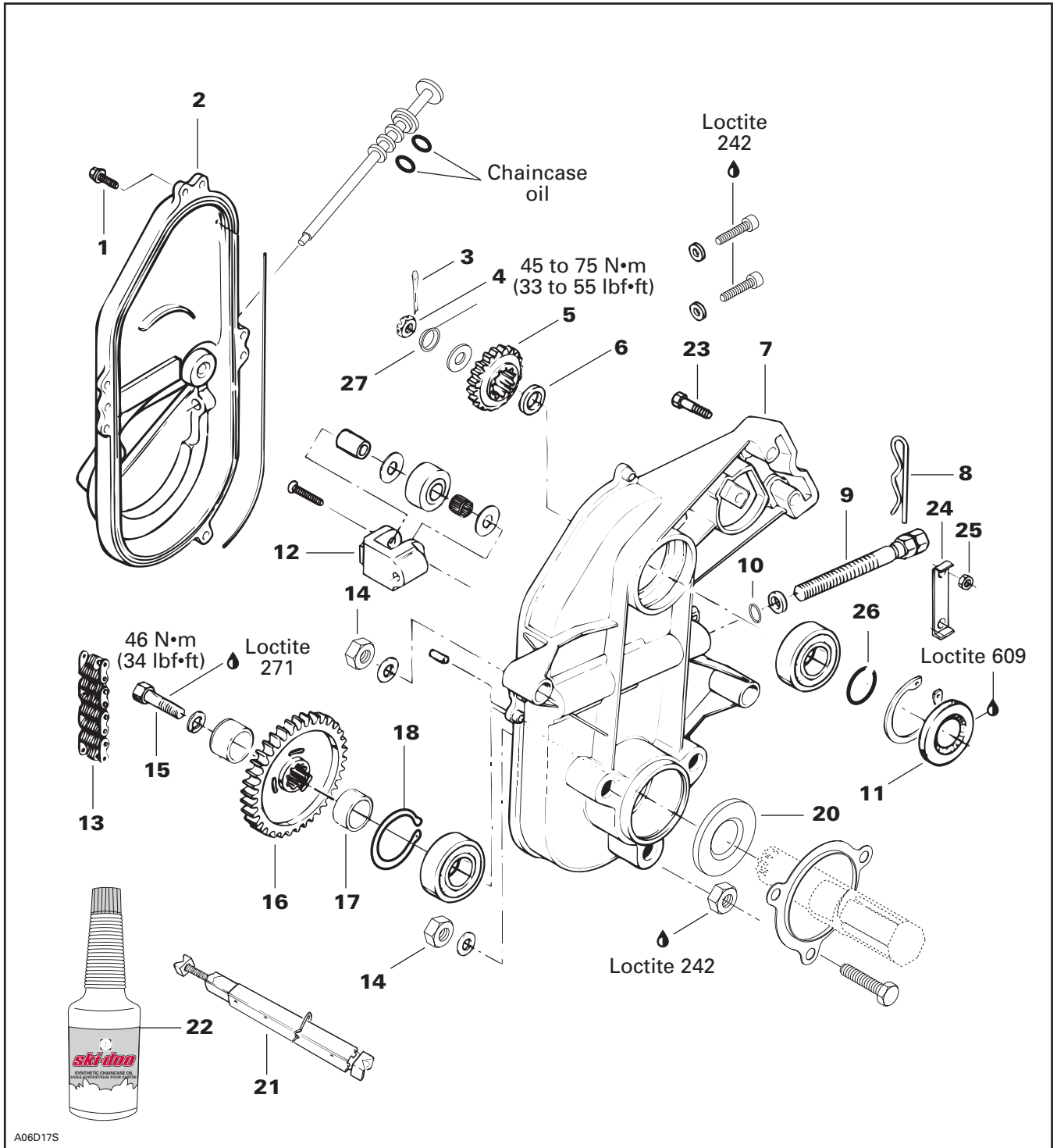

A06D17S

Section 04 TRANSMISSION

Sub-Section 07 (CHAINCASE)

REMOVAL

To remove chaincase proceed as follows.

Remove tuned pipes and muffler.

◆ WARNING

Never remove exhaust components when engine is hot.

Remove hair pin **no. 18**. Release drive chain tension by unscrewing tensioner adjustment screw.

Drain oil by removing chaincase cover **no. 2**.

3,4,5,6,13,16,17, Cotter Pin, Nut, Sprocket, Shim and Drive Chain

Remove cotter pin **no. 3**, nut **no. 4**, washer **no. 27** retaining upper sprocket **no. 5** and screw **no. 15** retaining lower sprocket **no. 16**. Pull sprockets and drive chain simultaneously. Remove shims **nos. 6** and **17**.

NOTE: Should countershaft removal be required, refer to BRAKE 04-06 then look for **Brake disc**.

Remove 5 nuts **no. 14**. Three nuts are behind the lower sprocket.

Unfold locking tab **no. 24**, unscrew nuts **no. 25** then remove caliper retaining screws **no. 23**.

Release track tension, use drive axle holder **no. 21** (P/N 529 0072 00).

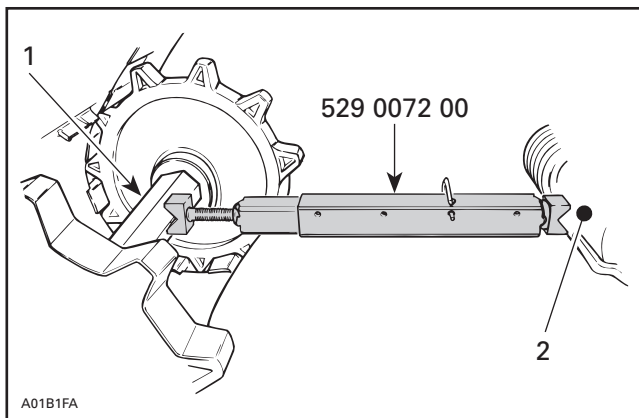

TYPICAL

1. Drive axle
2. Suspension cross shaft

Pry out drive axle oil seal **no. 20** from chaincase.

Pull chaincase from drive axle and countershaft.

Using 2 large screwdrivers inserted between chaincase **no. 7** and frame, pry complete assembly from vehicle.

INSPECTION

Visually inspect the chain for cracked, damaged or missing links. Check for worn or defective bearings, sprockets and chain tensioner components.

◆ WARNING

If chain deflection is greater than 38 mm (1.5 in) (without chain tensioner), replace chain and check condition of sprockets.

GEAR RATIO MODIFICATION

For particular applications, the number of teeth of the sprockets can be increased or decreased on lower and upper sprockets.

Refer to TECHNICAL DATA 09-03 for gear ratios.

▼ CAUTION

Gear ratio modifications should only be performed by experienced mechanics since they can greatly affect vehicle performance.

NOTE: For high altitude regions, the *High Altitude Technical Booklet* (P/N 484 0648 00 and P/N 484 0545 00 for binder) gives information about calibration according to altitude.

INSTALLATION

Reverse removal procedure and pay attention to the following. Replace oil seals, gaskets and O-rings.

Refer to DRIVE AXLE 06-03 for drive axle axial play adjustment.

11, Oil Seal

Clean chaincase bore with Loctite Safety Solvent (P/N 413 7082 00) then apply Loctite 609 to oil seal mounting surface (outside).

Using an appropriate pusher, press the oil seal into chaincase hub. Oil seal must fit flush with the chaincase edge.

NOTE: Should installation procedure for countershaft be required, refer to BRAKE 04-06 then look for **Brake disc and Countershaft bearing adjustment**.

5,16, Sprockets

Position the sprockets with the writing facing the chaincase cover.

27, Conical Spring Washer

Install washer with its concave side towards drive pulley.

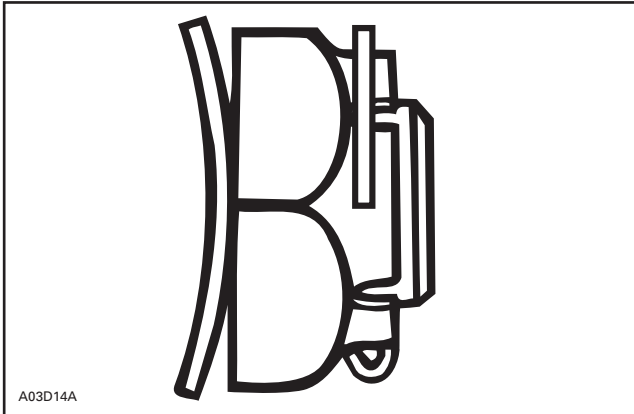

4, Upper Sprocket Castellated Nut

Torque to 45 to 90 N•m (33 to 66 lbf•ft).

Install new cotter pin in the position shown.

CAUTION
When removing a cotter pin always replace with a new one.

CAUTION
Cotter pin will rub on chaincase cover if installed otherwise.

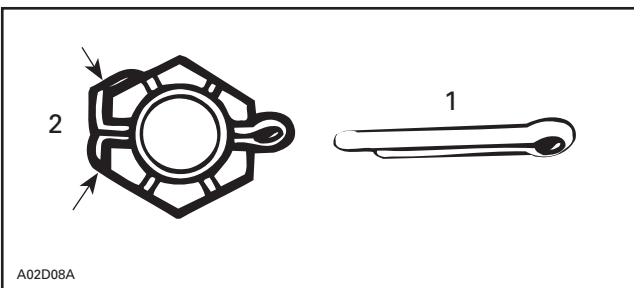

1. New
2. Fold cotter pin over castellated nut flats only

18, Circlip

CAUTION
It is of the utmost importance to install the circlip otherwise damage to the chaincase components may occur.

DRIVE CHAIN ADJUSTMENT

NOTE: Brake disc key must be in good condition before checking chain free play.

10, O-ring

Replace O-ring **no. 10** on tensioner adjustment screw. Fully tighten tensioner adjustment screw **by hand**, then back off only far enough for hair pin to engage in locking hole.

This initial adjustment should provide 3-5 mm (1/8-13/64 in) free-play when measured at the outer circumference of the brake disc.

CAUTION
Free-play must not exceed 5 mm (13/64 in), readjust if necessary.

WARNING
If the specified free-play is not reached with the tensioner screw fully tightened, replace chain and check the condition of sprockets.

22, Chaincase Oil

Pour 250 mL (8.5 fl. oz) of synthetic chaincase oil (P/N 413 8033 00) into chaincase.

NOTE: Chaincase oil capacity is 250 mL (8.5 fl. oz).

Check oil level with the dipstick then add if required. Remove metal particles from magnet.

Section 04 TRANSMISSION

Sub-Section 07 (CHAINCASE)



TYPICAL

1. Dipstick

NOTE: Chaincase must be in its proper position when checking oil level.

ADJUSTMENT

Pulley Alignment

Refer to PULLEY DISTANCE AND ALIGNMENT 04-05.

Track Tension and Alignment

Refer to TRACK 06-04.

DRIVE CHAIN

SILENT CHAIN

For 1997 there are 2 types of silent chain. One is 11-plate wide and the other (stronger) is 13-plate wide. Do not interchange sprockets. Fit chain on sprockets to make sure using right ones according to width. Refer to TECHNICAL DATA 09-03.

NOTE: No work (separation, lengthening) can be done on the silent chain type.

TABLE OF CONTENTS

WIRING DIAGRAMS	05-02-1
CHART CODES.....	05-02-1
UNPLUGGING CONNECTORS.....	05-02-3
TAB AND RECEPTACLE CONNECTORS REMOVAL.....	05-02-3
TAB AND RECEPTACLE CONNECTORS INSTALLATION.....	05-02-3
ACCESSORIES INSTALLATION.....	05-02-4
<hr/>	
IGNITION TIMING	05-03-1
NIPPONDENSO TRIGGER COIL SYSTEM	05-03-1
<hr/>	
SPARK PLUGS	05-04-1
NGK SPARK PLUG	05-04-1
NGK SPARK PLUG NUMBERING SYSTEM.....	05-04-1
1997 REFERENCE CHART.....	05-04-1
DESIGN SYMBOLS USED IN NGK SPARK PLUGS	05-04-2
DISASSEMBLY.....	05-04-3
HEAT RANGE.....	05-04-3
FOULING.....	05-04-3
SPARK PLUG ANALYSIS.....	05-04-3
SPARK PLUG INSTALLATION.....	05-04-4
SPARK PLUG TIGHTENING TORQUE.....	05-04-4
<hr/>	
TESTING PROCEDURE	05-05-1
GENERAL.....	05-05-1
USE OF BOMBARDIER IGNITION TESTER.....	05-05-2
NIPPONDENSO CDI TRIGGER COIL SYSTEM TESTING	05-05-3
TRIGGER COIL OUTPUT.....	05-05-3
IGNITION COIL OUTPUT.....	05-05-3
IGNITION MODULE.....	05-05-4
MAGNETO OUTPUT (IGNITION GENERATOR COIL).....	05-05-5
LIGHTING GENERATOR COIL OUTPUT.....	05-05-5
SUMMARY TABLE.....	05-05-6
RESISTANCE MEASUREMENTS.....	05-05-7
VOLTAGE REGULATOR INSPECTION	05-05-8
TESTING PROCEDURE.....	05-05-8
INSPECTION OF AC CIRCUIT ISOLATION	05-05-9
INSPECTION.....	05-05-9
INSPECTION OF HEATING ELEMENTS	05-05-10

WIRING DIAGRAMS

MODEL	WIRING DIAGRAM PAGE	HEADLIGHT (watt)	TAILLIGHT (watt)	ELECTRICAL SYSTEM OUTPUT (watt)
Formula III/III LT Mach 1/Z/Z LT	Annex 1	60/55 hal.	8/27	220

hal. = halogen

CHART CODES

Wiring Color Code

The first color of a wire is the main color, second color is the stripe.

Example: YL/BK is a YELLOW wire with a BLACK stripe.

COLOR CODE	
BK — BLACK	GN — GREEN
WH — WHITE	GY — GREY
RD — RED	VI — VIOLET
BL — BLUE	OR — ORANGE
YL — YELLOW	BR — BROWN

Section 05 ELECTRICAL**Sub-Section 02 (WIRING DIAGRAMS)**

Following table shows wire colors related to electrical circuits.

WIRE COLORS	ELECTRICAL CIRCUIT	ADDITIONAL INFORMATION
BLACK/YELLOW	ENGINE SHUT OFF – Key switch – Tether cord switch – Emergency switch	Must be grounded to stop engine.
BLACK (small)	Ground for shut off	
BLACK (Big)	Ground for starter (–)	
YELLOW YELLOW/BLACK	12 volts (A.C.)	If shorted, magneto stops producing electricity.
RED	12 volts (D.C.) (+) For starter motor	
RED/GREEN	12 volts (D.C.) (+) For starter solenoid	
RED/BLUE	12 volts (D.C.) (+) Rectifier output	
GREY	12 volts (A.C.) High beam	Current returns by YELLOW/BLACK wire connected to headlamp.
VIOLET/GREY	12 volts (A.C.) Low beam	
WHITE	12 volts (A.C.) Brake light	Current returns by YELLOW/BLACK wire connected to taillight.
WHITE/RED	12 volts (A.C.) Low oil level	Current returns by YELLOW/BLACK wire connected to oil level sensor.
BLUE	12 volts (A.C.) Fuel level indicator	Current returns by YELLOW wire connected to fuel level sensor.
ORANGE	12 volts (A.C.) Heated grips (max.)	Current returns by YELLOW/BLACK wire connected to heating elements.
ORANGE/VIOLET	12 volts (A.C.) Heated grips (min.)	
BROWN	12 volts (A.C.) Heated throttle lever (max.)	
BROWN/YELLOW	12 volts (A.C.) Heated throttle lever (min.)	
GREEN	12 volts (A.C.) Temperature gauge	Current returns by YELLOW wire connected to sensor.
VIOLET	12 volts (A.C.) Engine overheating light.	

Connector Location

Connectors on wiring diagrams carry the letter C followed by a number. Use this code with wiring diagram legend to find connector location on vehicle.

UNPLUGGING CONNECTORS

Always unplug connectors by pulling on housing not on wire.



TYPICAL

TAB AND RECEPTACLE CONNECTORS REMOVAL

Tab Connector

It is locked in its housing by a spring tab on its side. Removal is done by squeezing this tab.

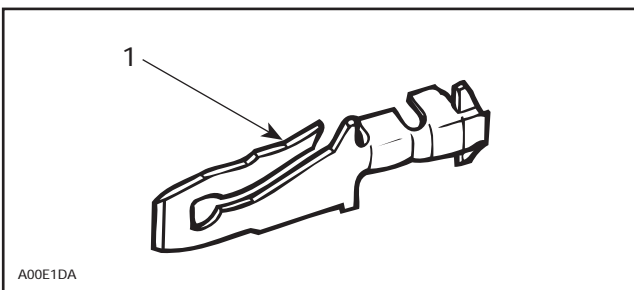

TAB CONNECTOR

1. Locking tab

To remove:

- Insert a screwdriver or Snap-on TT 600-5 from opposite side of wire and pry locking tab.
- While holding locking tab pried, pull connector toward wire side.

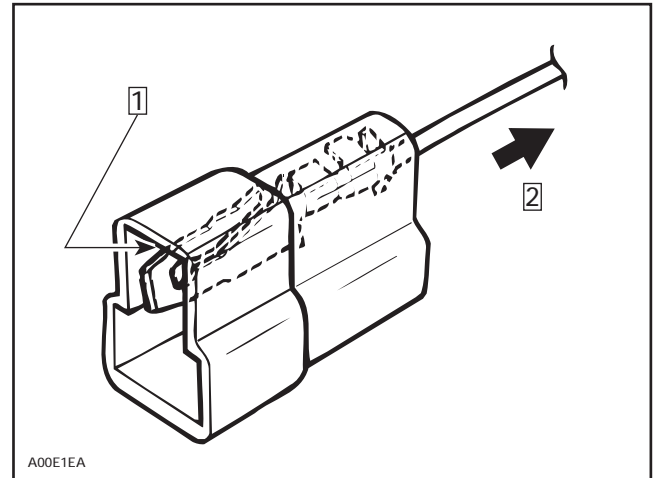

Step 1: Insert screwdriver here

Step 2: Pull this side

Locking Receptacle Connector

To remove:

- Insert tool Snap-on TT 600-5 in access opening then pull housing toward wire side.

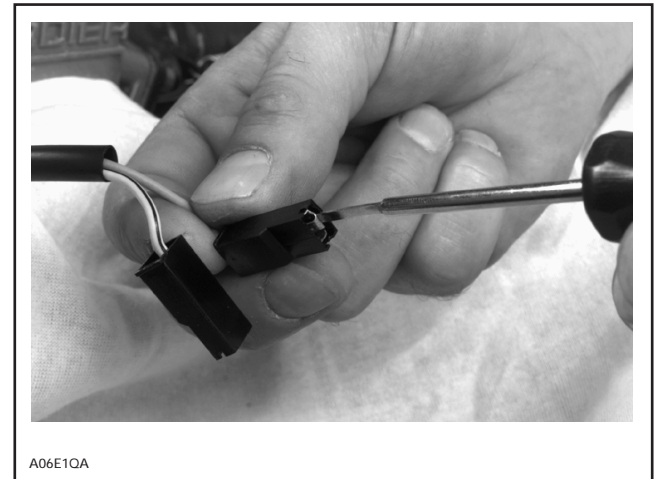

TAB AND RECEPTACLE CONNECTORS INSTALLATION

Prior to installing, make sure locking tab is sufficiently lifted to properly lock.

Insert tab and receptacle connectors in their respective housings as shown in following illustrations. Push sufficiently so that they snap. Try pulling wire to ensure they are properly locked.

Section 05 ELECTRICAL

Sub-Section 02 (WIRING DIAGRAMS)

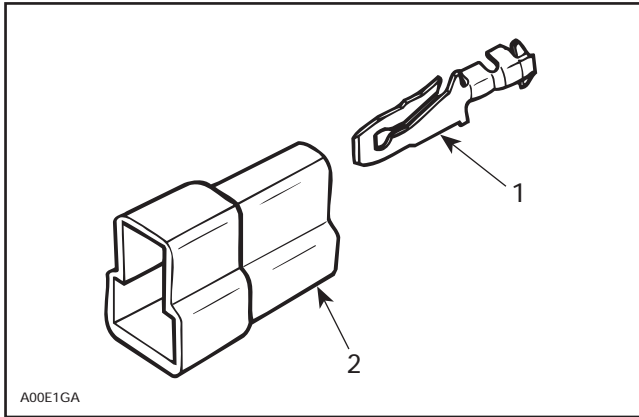

1. Tab
2. Housing

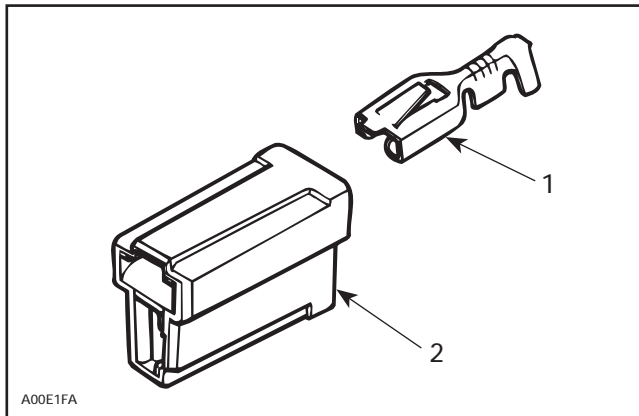

TYPICAL

1. Receptacle
2. Housing

ACCESSORIES INSTALLATION

On all electric start models: The direct current (DC) utilizes the snowmobile frame as ground "wire" while all alternating current (AC) consumers (lights, heated grips, fuel gauge, etc.) utilize a separate ground wire.

Never interconnect AC and DC grounds as an AC voltage drop will result. When installing accessories on any snowmobile, connect their wires directly to the YELLOW and YELLOW/BLACK lighting coil wires.

Even if manual start models have an AC ground to the chassis (on voltage regulator), all accessories utilize a ground wire isolated from chassis. When an electric starter kit is installed, the voltage regulator and its ground wire are replaced by a voltage rectifier/regulator unit permitting a completely isolated AC circuit.

◆ WARNING

Never secure electrical wires/cables with fuel lines. Keep wires away from any rotating, moving, heating, vibrating or sharp edge. Use proper fastening devices as required.

IGNITION TIMING

NIPPONDENSO TRIGGER COIL SYSTEM

Ignition timing is adjusted by movement of trigger coil. Raising position of trigger coil retards ignition. Lowering position of trigger advances ignition.

▼ CAUTION

Each time ignition timing is adjusted by moving trigger coil, air-gap must be adjusted.

Refer to CDI MAGNETO 04-04 then look for Trigger Coil Adjustment after adjusting ignition timing.

Verifying Magneto Flywheel Timing Mark Position

Prior to checking the timing, it may be necessary to verify the position of the timing mark on the magneto flywheel, for the following reasons:

1. To detect a missing or broken magneto flywheel Woodruff key which would allow a change of timing to occur, with eventual break down of the engine.
2. To correctly locate and mark a timing mark on a new service magneto flywheel.
3. To verify the correct location of the factory timing mark.
4. To detect a wrong magneto flywheel.

To verify the position of the timing mark on the magneto flywheel or to scribe a timing mark, proceed as follows:

1. Clean the area around the spark plugs, and remove them.
2. Remove the rewind starter from the engine.
3. Install the TDC gauge in the spark plug hole, (magneto side) and adjust as follows:
 - a. Position the magneto flywheel at approximately TDC.

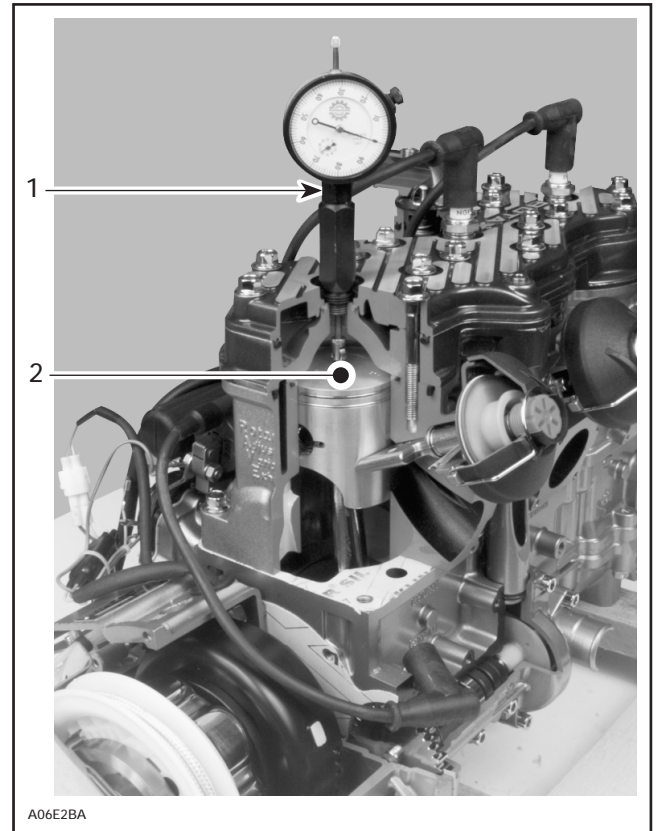

A06E2BA

TYPICAL

1. TDC gauge on MAG side
2. MAG side piston at TDC

- b. Assemble the gauge to the adaptor and tighten the roller lock nut. Do not tighten the adaptor lock nut.
 - c. Screw the adaptor into the spark plug hole and tighten to prevent movement in the plug hole.
 - d. Position the dial face toward the magneto. Move the gauge down until the needle just begins to move, then move down a further 5 or 6 mm (approximately 1/4 in). Tighten adaptor lock nut by hand.
4. Locate the piston TDC position as follows:
 - a. Slowly rotate the magneto flywheel back and forth across TDC while observing the needle. Note that the needle stops moving only as the piston is changing direction.

Section 05 ELECTRICAL

Sub-Section 03 (IGNITION TIMING)

- b. Rotate the dial face so that "0" is in line with the needle when it stops moving.
- c. Again, slowly rotate the magneto flywheel back and forth across TDC and adjust the dial face to "0", until the needle always stops exactly at "0" before changing direction.
- d. "0" now indicates exact TDC.

5. Verify the position of the timing mark on the magneto flywheel as follows:

NOTE: When checking timing, certain procedures require that the magneto flywheel be turned in a clockwise direction, viewed facing the magneto. If it is necessary to turn back (counterclockwise) for any reason, rotate the magneto flywheel at least one-quarter turn counterclockwise, and then rotate it clockwise. The last magneto flywheel movement when making a critical check must always be in a clockwise direction, to ensure that the slack in engine moving parts is taken-up.

- a. Rotate the magneto flywheel counterclockwise, one-quarter turn then carefully rotate it clockwise until the needle indicates the specified measurement, indicated in TECHNICAL DATA 09-02.
- b. Make sure that the dot located on the side of the magneto flywheel protrusion perfectly aligns with center of trigger coil core, refer to illustration.
- c. If the marks do not align, loosen trigger coil screws and move trigger coil to align dot with center of trigger coil core.

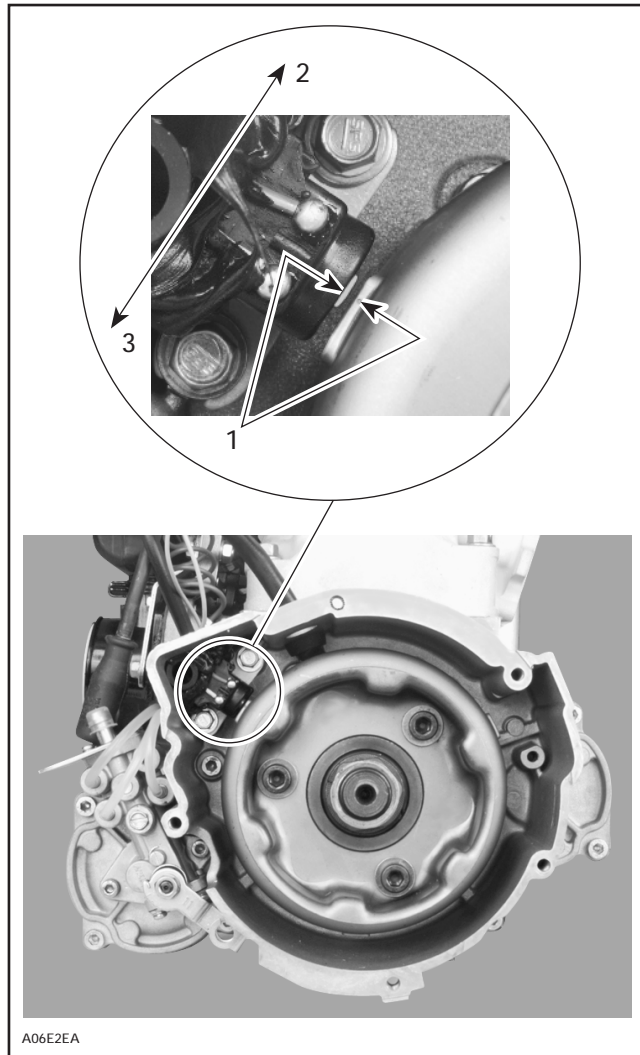

1. Dot aligned with center of trigger coil core
2. Retard
3. Advance

NOTE: These marks can not be used to check dynamic (with engine running) ignition timing with a timing light: an other mark is scribed on magneto flywheel or damper for this purpose. When flywheel protrusion dot aligns with center of trigger coil core, flywheel mark and crankcase center mark must be aligned.

Checking Ignition Timing

Use timing light (P/N 529 0319 00).

To check the ignition timing, refer to illustration and proceed as follows:

NOTE: Engine should be cold when checking timing. Do not idle engine for more than 20 seconds and make checks quickly.

◆ WARNING

Place ski tips against a wall, raise rear of vehicle on a stand, so that track does not contact the ground. Do not allow anyone in front of or behind the vehicle while engine is running. Keep clear of track and do not wear loose clothing which can get caught in moving parts.

1. Connect the timing light pick-up to a spark plug cable and the power connections to the battery.

NOTE: To avoid an incorrect reading due to parallax, view the magneto flywheel and the crankcase timing marks in a straight line.

2. Start the engine and point timing light straight in line with the crankcase timing mark. Bring engine to 6000 RPM for a brief instant.

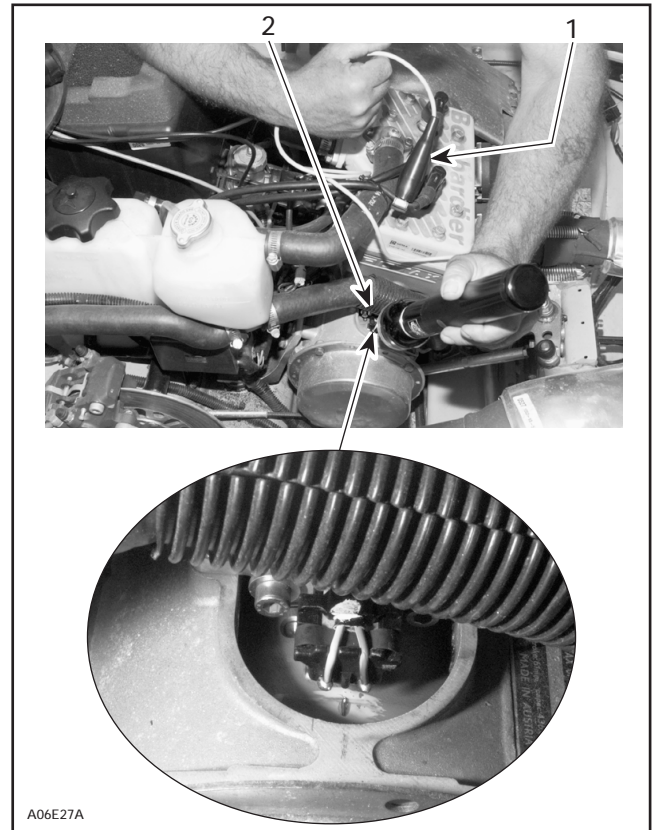

TYPICAL

1. Timing light pick-up on MAG side
2. Timing inspection hole

The magneto/damper mark must be aligned with center mark. If not, move trigger coil as explained above and recheck ignition timing. Tolerance is $\pm 1^\circ$.

If the marks still do not align, a faulty trigger coil (check proper grounding of coil) or a faulty CDI module could be the cause: substitute one part at a time and recheck timing marks (check connectors condition prior to substituting any part).

SPARK PLUGS

NGK SPARK PLUG

All Models

NGK SPARK PLUG NUMBERING SYSTEM

Bombardier is using the NGK spark plug type on most of the 1997 snowmobile models.

The heat range identification system is:

High number —————▶ hot plug
Low number —————▶ cold plug

1997 REFERENCE CHART

NGK spark plugs used on 1997 Bombardier snowmobiles covered in this manual:

- BR10ES

Section 05 ELECTRICAL

Sub-Section 04 (SPARK PLUGS)

DESIGN SYMBOLS USED IN NGK SPARK PLUGS

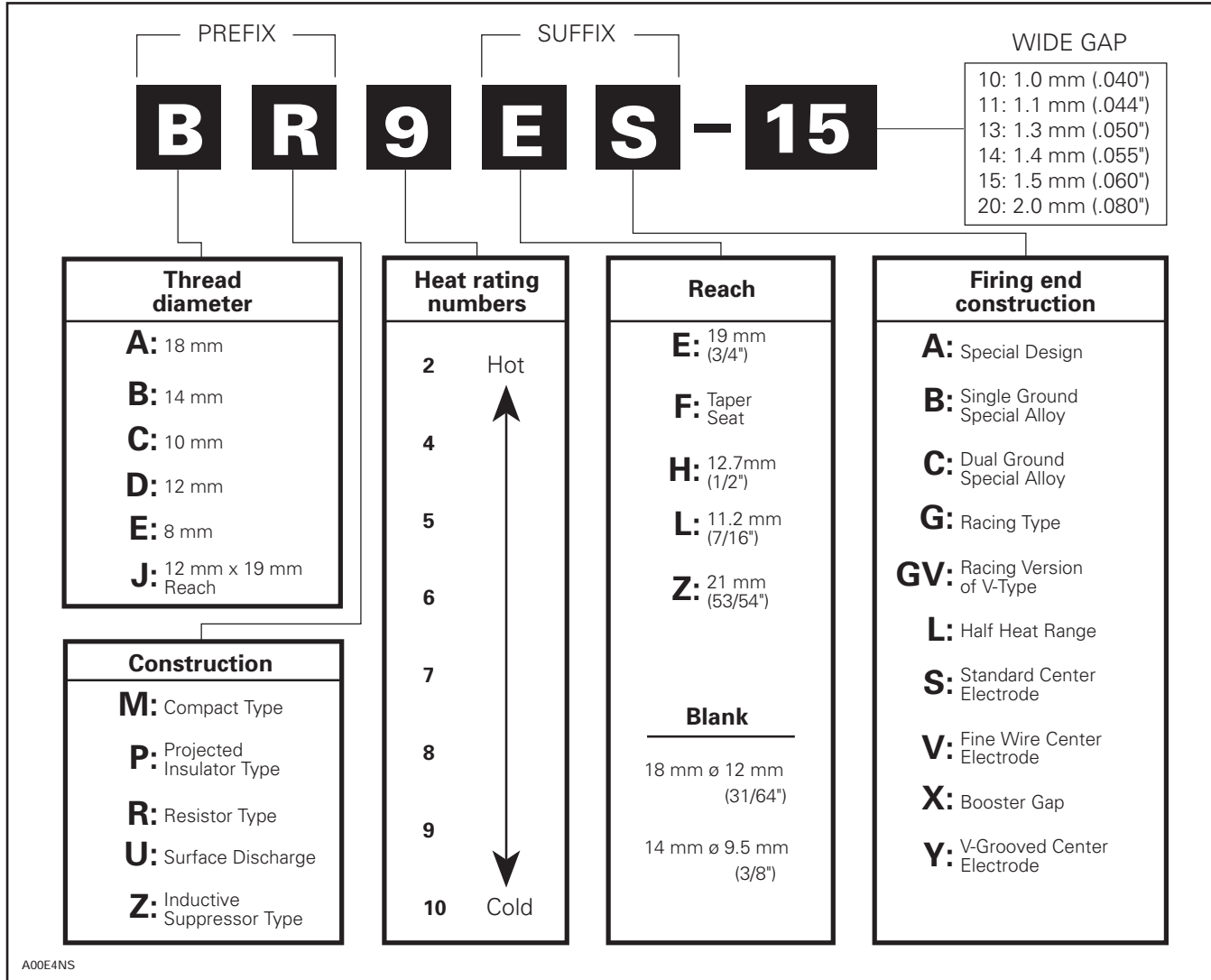

CROSSCUTS AND GAP STYLES OF SPARK PLUGS

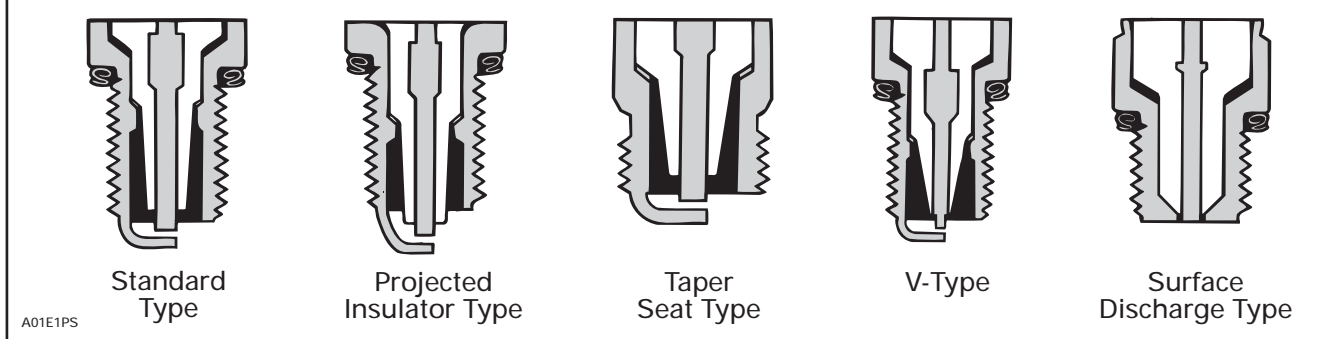

DISASSEMBLY

First unscrew the spark plug 1 turn.

Clean the spark plug and cylinder head with pressurize air then completely unscrew.

◆ WARNING

Whenever using compressed air, always wear protective eye wear.

HEAT RANGE

The proper operating temperature or heat range of the spark plugs is determined by the spark plug ability to dissipate the heat generated by combustion.

The longer the heat path between the electrode tip to the plug shell, the hotter the spark plug operating temperature will be — and inversely, the shorter the heat path, the colder the operating temperature will be.

A “cold” type plug has a relatively short insulator nose and transfers heat very rapidly into the cylinder head.

Such a plug is used in heavy duty or continuous high speed operation to avoid overheating.

The “hot” type plug has a longer insulator nose and transfers heat more slowly away from its firing end. It runs hotter and burns off combustion deposits which might tend to foul the plug during prolonged idle or low speed operation.

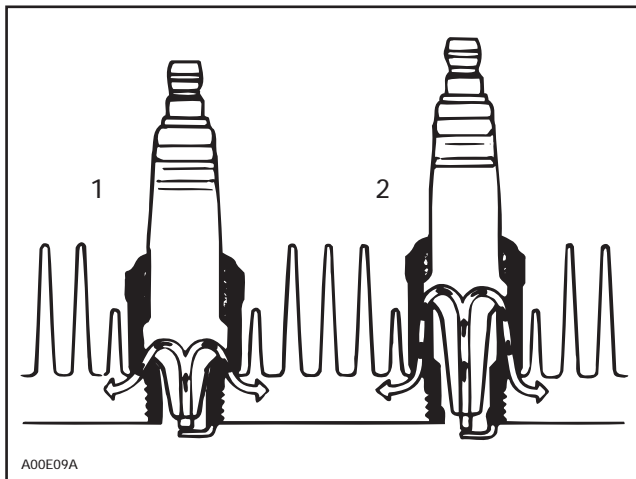

1. Cold
2. Hot

▼ CAUTION

Severe engine damage might occur if a wrong heat range plug is used.

A too “hot” plug will result in overheating and pre-ignition, etc.

A too “cold” plug will result in fouling (shorting the spark plug) or may create carbon build up which can heat up red-hot and cause pre-ignition or detonation.

FOULING

Fouling of the spark plug is indicated by irregular running of the engine, decreased engine speed due to misfiring, reduced performance, and increased fuel consumption. This is due to a loss of compression. Other possible causes are: prolonged idling, or running on a too rich mixture due to a faulty carburetor adjustment or incorrect fuel and/or fuel mixing. The plug face of a fouled spark plug has either a dry coating of soot or an oily, glossy coating given by an excess either of oil or of oil with soot. Such coatings form a conductive connection between the center electrode and ground.

SPARK PLUG ANALYSIS

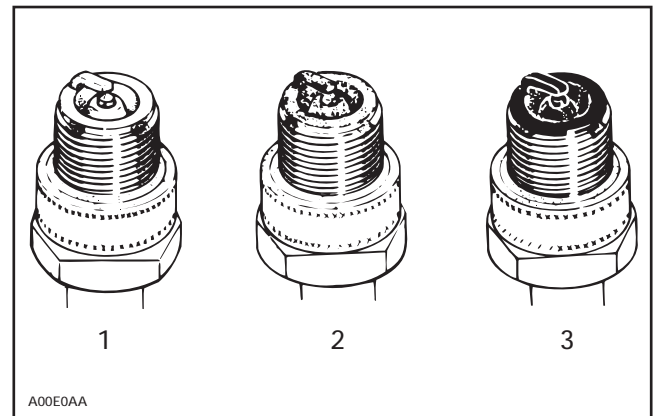

1. Overheated (light grey)
2. Normal (brownish)
3. Fouled (black)

The plug electrode (and piston dome) reveals the condition of the engine, operating condition, method of driving and fuel mixture. For this reason it is advisable to inspect the spark plug at regular intervals, examining the plug electrode and the piston dome.

Section 05 ELECTRICAL

Sub-Section 04 (SPARK PLUGS)

SPARK PLUG INSTALLATION

Prior to installation make sure that contact surfaces of the cylinder head and spark plug are free of grime.

1. Using a wire feeler gauge, set electrode gap according to TECHNICAL DATA 09-02.
2. Apply anti-seize lubricant (P/N 413 7010 00) over the spark plug threads to prevent possible seizure.
3. Hand screw spark plug into cylinder head and tighten with a torque wrench and a proper socket.

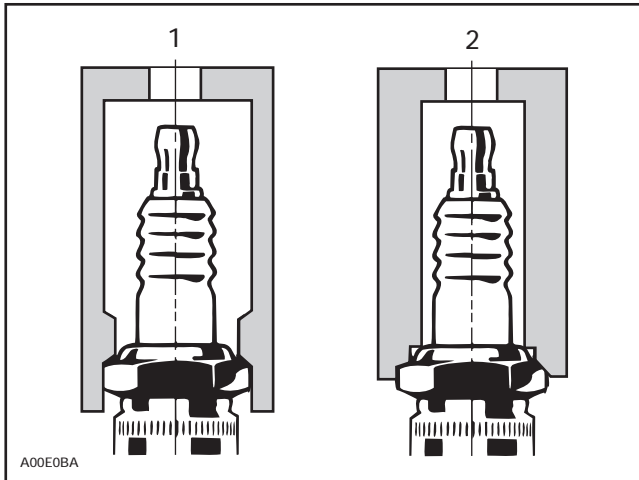

1. Proper socket
2. Improper socket

SPARK PLUG TIGHTENING TORQUE

Models	Spark plugs	Torque N•m (lbf•ft)
All models	NGK	27 (20)

TESTING PROCEDURE

GENERAL

The following chart gives the engine types with their implemented system.

ENGINE TYPE	IGNITION SYSTEM	CHARGING SYSTEM OUTPUT
599, 699 and 809	① NIPPONDENSO (CDI) TRIGGER COIL	220

CDI System Identification

Nippondenso

1. Ignition module is connected to the ignition generator coil via a 3-wire connector (BLACK/RED, WHITE and RED wires).

599, 699 and 809 Engines

Ignition module stamped P/N: 070000-2341

Ignition coil stamped P/N: 129700-2990 or 129700-2991

Flywheel stamped P/N: 032000-7902

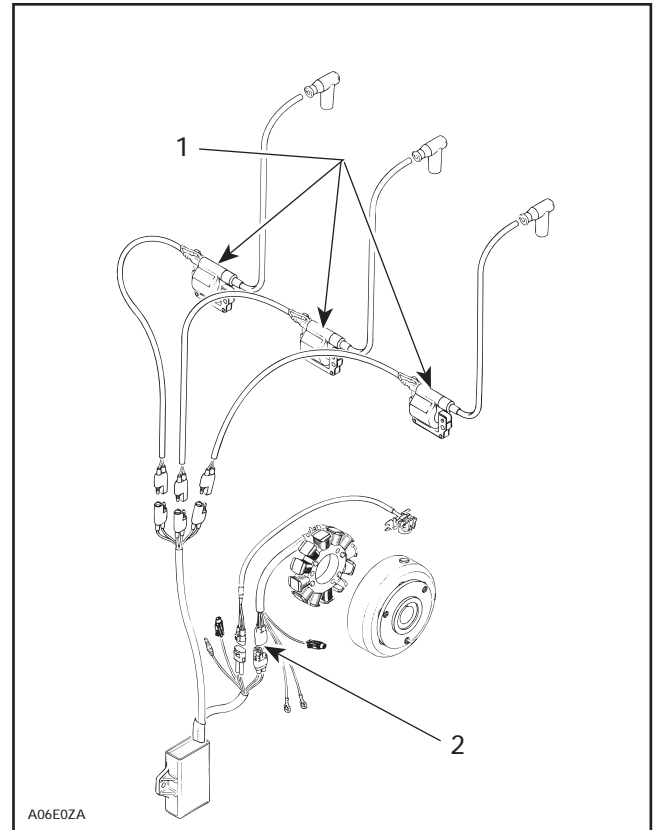

① **NIPPONDENSO CDI TRIGGER COIL WITH 3 H.T. COILS**
1. Separate high tension coils mounted on carburetor flanges
2. Three-wire connector (BLACK/RED, WHITE and RED)

Ignition System Testing Sequence

When dealing with ignition problems, the following items should be verified in this order.

Nippondenso

1. Spark occurrence/spark plug condition.
2. Electrical connections.
3. Engine stop/tether cord switches.
4. Ignition coil output.
5. Ignition module output.
6. Magneto output (ignition generator coil).

▼ CAUTION

Whenever replacing a component in ignition system, check ignition timing.

The first 2 items can be checked with known automotive equipment and other items as follows.

Section 05 ELECTRICAL

Sub-Section 05 (TESTING PROCEDURE)

Engine Stop/Tether Cut-Out Switches Verification

Engine Stop Switch

Unplug stop switch connector from main harness then using an ohmmeter, connect test probes to BLACK/YELLOW and BLACK wires.

Measure resistance, it must be an open circuit in its operating position and close to 0 ohm when depressed.

Tether Cut-Out Switch

Unplug tether cut-out switch connector from main harness then using an ohmmeter, connect test probes to BLACK/YELLOW and BLACK wires.

Measure resistance, it must be an open circuit when cap is over switch and close to 0 ohm when removed.

Magneto System Verification

System verification can be performed using the Bombardier ignition tester (P/N 419 0033 00), a digital ohmmeter or by substituting parts.

USE OF BOMBARDIER IGNITION TESTER

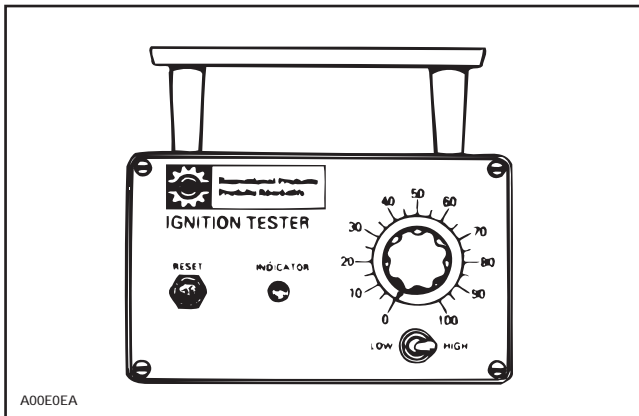

NOTE: For more information about operating and maintenance of the tester, refer to its instruction manual.

Test Condition

All Tests are Performed on the Vehicle at Cranking Speed

Vigorous manual cranking against compression causes the flywheel to snap over, raising the output higher than by cranking without compression, therefore, do not remove spark plug.

Test Values Listed are Taken Against Compression

Always crank vigorously as in actual starting.

Always proceed in the following order:

1. Connect tester P and N clip leads as illustrated for each specific test.
2. Follow test procedure sequence.
3. After every test that lights the indicator lamp, reset the indicator circuit by depressing the reset button.

Analysis of Test Results

Indicator Lamp Lights at Specific Setting

Output is as specified. Test results should repeat 3 times. If readings do not repeat, output is erratic and cause should be investigated (loose connections or components etc.).

Indicator Lamp Lights at Lower Setting

This indicates that the output is less than that designed to operate in a satisfactory manner. However, before coming to the conclusion of a faulty condition, be certain that correct engine cranking conditions were met before condemning the tested part.

Indicator Lamp Does Not Light

One component is defective. Proceed as instructed to find defective component.

Intermittent Ignition Problems

In dealing with intermittent problems there is no easy diagnosis. For example, problems that occur only at normal engine operating temperature have to be tested under similar conditions.

In most cases of temperature and/or vibration failure, only parts replacement can solve the problem as most of these failures return to normal when engine is not running.

Multiple Problems

There is always the possibility of more than one faulty part. If after a component has been replaced, the problem still persists, carefully repeat the complete test procedure to find the other faulty part.

NIPPONDENSO CDI TRIGGER COIL SYSTEM TESTING

Applicable to 599, 699 and 809 Engine Types

NOTE: Ensure ignition cut-out switches are properly working and they are in the ON position prior to performing the following tests.

◆ WARNING

To prevent powerful electric shocks while cranking engine, do not touch neither electronic ignition components (ignition coil, high tension wire, wire harness, etc.) nor tester leads.

TRIGGER COIL OUTPUT

1. Disconnect connector housing of trigger coil at ignition module.
2. Connect tester wires then set switch and dial as follows:

Tester wires	Component wires	Tester switch position	Tester dial position
N	BLUE/YELLOW wire of trigger coil	LOW	15
P	WHITE/YELLOW wire of trigger coil		

3. Crank engine and observe indicator.
4. Push reset button and repeat step 3 twice.

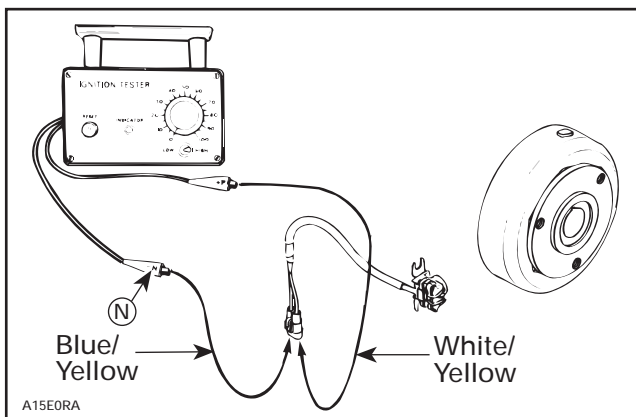

TYPICAL

Results:

- a. Indicator lamp lights: Trigger coil output is up to specifications.
- b. Indicator lamp does not light: The problem is a faulty trigger coil or bad grounding.

IGNITION COIL OUTPUT

A paper clip of approximately 20 mm (3/4 in) will be used as a test adapter for the following test.

1. Install the test adapter to spark plug cable close to MAG side spark plug.
2. Connect tester wires then set switch and dial as follows:

Tester wires	Component wires	Tester switch position	Tester dial position
N	Engine ground	LOW	45
P	Test adapter (paper clip) spark plug cable		

NOTE: Different reading occurs if N tester wire is connected to PTO or MAG side spark plug cable.

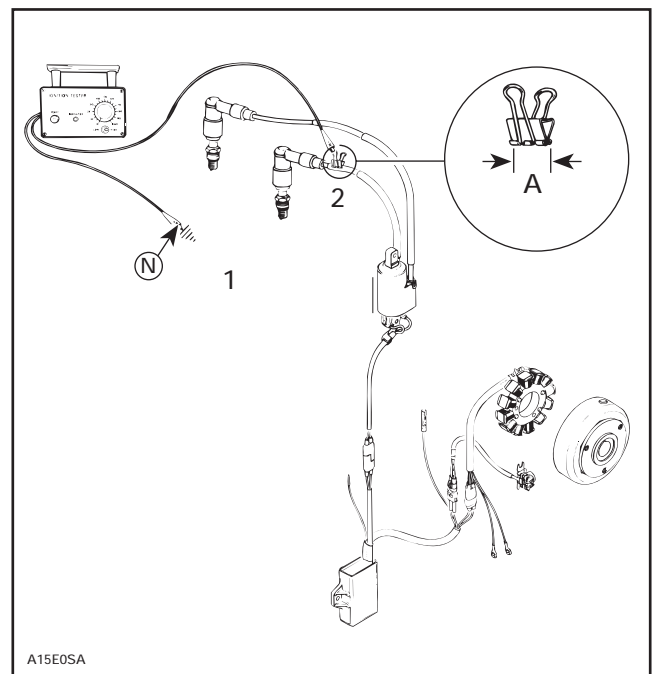

TYPICAL

1. Engine ground
2. MAG side
- A. 20 mm (3/4 in)

Section 05 ELECTRICAL

Sub-Section 05 (TESTING PROCEDURE)

3. Crank engine and observe indicator.

NOTE: If engine starts, allow it to idle while observing indicator. Then, shut engine off.

4. Push reset button and repeat step 3 twice.

Results:

- Indicator lamp lights: Ignition system is OK.
- Indicator lamp does not light on one or both cylinder: Proceed to following tests.

IGNITION MODULE

1. Disconnect connector at ignition coil.

At assembly, secure with new locking ties.

2. Connect an ignition coil (known as being in good condition) to the spark plug(s).

3. Connect CDI module to replacement ignition coil.

4. Slip plastic protector out of coil terminal.

5. Connect tester wires to coil terminals then set switch and dial as follows:

NOTE: If necessary use jumper wires from coil terminals to tester wires.

Tester wires	Component wires	Tester switch position	Tester dial position
N	WHITE/BLUE wire (+) of ignition coil	LOW	85
P	BLACK wire (-) of ignition coil		

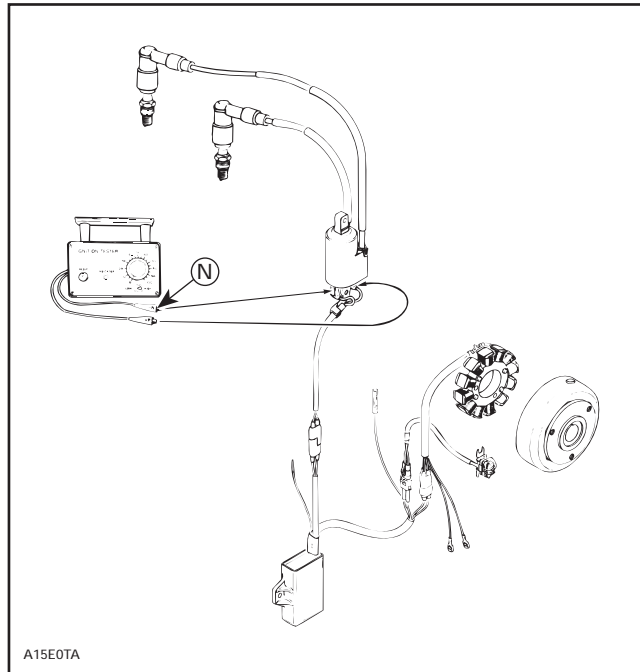

TYPICAL

6. Crank engine and observe indicator.

7. Push reset button and repeat step 6 twice.

Results:

- Indicator lamp lights: Ignition module output is up to specifications. The problem is a faulty ignition coil.
- Indicator lamp does not light: Proceed to following test. If magneto output tests good, the problem is a faulty ignition module.

MAGNETO OUTPUT (IGNITION GENERATOR COIL)

1. Disconnect the 3-wire connector between ignition module and magneto harness.
At installation, secure with new locking ties.
2. Connect tester wires then set switch and dial as follows:

Tester wires	Component wires	Tester switch position	Tester dial position
N	WHITE wire of magneto harness	LOW	75
P	BLACK / RED wire of magneto harness		
N	WHITE wire of magneto harness	LOW	85
P	RED wire of magneto harness		

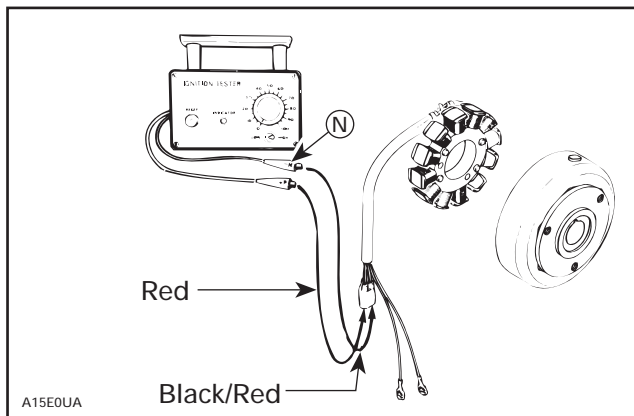

TYPICAL

3. Crank engine and observe indicator.
4. Push reset button and repeat step 3 twice.

LIGHTING GENERATOR COIL OUTPUT

NOTE: The lighting generator coil is not part of the ignition system. It is a separate system that supplies current to the lighting system and AC-powered devices. However it can be tested with the same tester.

1. Disconnect wiring harness junction block at engine (the one with YELLOW wires).
2. Connect tester wires then set switch and dial as follows:

Tester wires	Component wires	Tester switch position	Tester dial position
N	YELLOW wire of magneto harness	LOW	75
P	YELLOW wire of magneto harness		

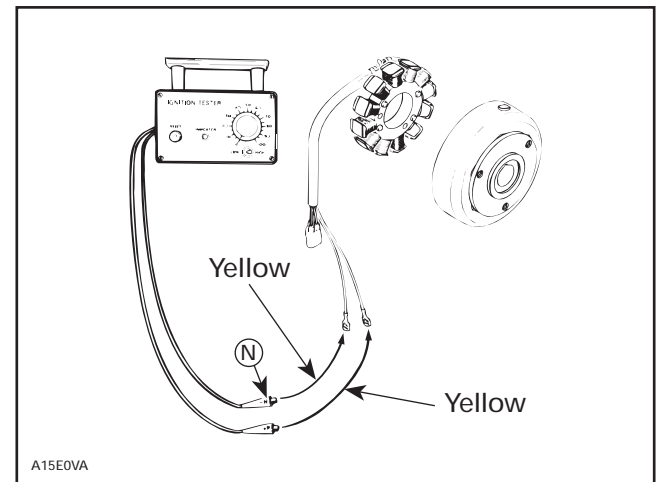

3. Crank engine and observe indicator.
4. Push reset button and repeat step 3 twice.

Results:

- a. **Indicator lamp lights:** Lighting generator coil output is up to specifications.
- b. **Indicator lamp does not light:** Lighting generator coil is faulty.

Section 05 ELECTRICALSub-Section 05 (TESTING PROCEDURE)

SUMMARY TABLE

Test to perform	Tester wires	Components wires	Switch	Dial
Trigger coil output	N	BLUE/YELLOW wire of trigger coil	LOW	15
	P	WHITE/YELLOW wire of trigger coil		
Ignition coil output	N	Engine ground	LOW	45
	P	Test adapter on MAG spark plug cable		
Ignition module output	N	WHITE/BLUE wire (+) of ignition coil	LOW	85
	P	BLACK wire (-) of ignition coil		
Magneto output (ignition generator coil)	N	WHITE wire of magneto harness	LOW	75
	P	BLACK / RED wire of magneto harness		
	N	WHITE wire of magneto harness	LOW	85
	P	RED wire of magneto harness		
Lighting generator coil output	N	YELLOW wire of magneto harness	LOW	75
	P	YELLOW wire of magneto harness		

RESISTANCE MEASUREMENTS

As an alternate method, magneto system components can be checked with a digital ohmmeter.

NOTE: All resistance measurements must be performed with parts at room temperature (borax. 20°C (68°F)). Temperature greatly affects resistance measurements.

Disconnect connector at ignition coil and magneto junction. Measure resistance between each terminal. Refer to the following table for values and wire colors.

NOTE: An ignition coil with good resistance measurement can still be faulty. Voltage leak can occur at high voltage level which is not detectable with an ohmmeter.

	PART NAME	WIRE COLOR*	RESISTANCE OHM	REMARKS
MAGNETO	Trigger coil	BL/YL with WH/YL	190 - 300	No display change means open circuit.
	Ignition generator coil	Low speed WH with RD	49 - 75	
	High speed WH with BK / RD	2.8 - 4.3		
IGNITION COIL	Primary winding	BK with WH/BL	0.3 - 0.7	Display showing zero (0) means short circuit.
	Secondary winding (spark plug cap remove)	End of each high tension wire	8 - 16 K (8000 - 16000)	
	Insulation	WH/BL with core	$\infty\Omega$	
		WH/BL with high tension wire		
SPARK PLUG CAP	Spark plug cap	—	4.5 - 5.5 K	

∞ : Infinity (extremely large number)

* COLOR CODE	
BK — BLACK	GN — GREEN
WH — WHITE	GY — GREY
RD — RED	VI — VIOLET
BL — BLUE	OR — ORANGE
YL — YELLOW	BR — BROWN

Section 05 ELECTRICAL

Sub-Section 05 (TESTING PROCEDURE)

VOLTAGE REGULATOR INSPECTION

A faulty voltage regulator is often responsible for frequent burned bulbs.

TESTING PROCEDURE

The regulator ground must be checked to ensure the circuit is complete. If necessary, connect a good ground wire from the regulator to the engine.

A) Quick Test Without Voltmeter

If a voltmeter is not available, a visual test can be performed with satisfactory results.

Disconnect all lights and electric equipment.

While engine is running, disconnect and connect regulator connector several times checking for a spark.

A spark on regulator terminal indicates a good and working regulator.

B) Voltmeter Test

NOTE: Use a voltmeter able to read alternating current (AC). For accurate reading, use a RMS voltmeter.

Connect a wire of the voltmeter to a YELLOW/BLACK wire.

Connect the other wire of the voltmeter to a YELLOW wire.

Lift the rear of vehicle and support with a mechanical stand.

Start the engine at an idle without opening the throttle.

◆ WARNING

Ensure the track is free of particles which might be thrown out while track is rotating. Keep hands, tools, feet and clothing clear of track. Ensure no-one is standing in close proximity to the vehicle.

Slowly open the throttle and accelerate the engine to increase the RPM.

If the meter reads over 15 volts, the regulator is defective and must be replaced.

▼ CAUTION

Do not increase the RPM so the voltage exceeds 15 V as the bulb(s) will burn.

NOTE: Whatever the voltmeter type used (peak voltage or RMS) the voltage must not exceed 15 V (a defective regulator will allow voltage to exceed 15 V as engine RPM is increased).

INSPECTION OF AC CIRCUIT ISOLATION

All Electric Start Models

If AC circuit is not isolated from frame, headlamp beam will weaken.

INSPECTION

Disconnect regulator/rectifier.

Connect one digital ohmmeter probe (needle ohmmeter will not offer enough precision) to frame and other probe to one of 2 yellow magneto wires.

Measured resistance must be infinite. If such is not the case, it means there is a connection between AC circuit and DC circuit.

Disconnect one accessory at the time to identify the faulty circuit.

Section 05 ELECTRICAL

Sub-Section 05 (TESTING PROCEDURE)

INSPECTION OF HEATING ELEMENTS

All measurements must be performed at 21°C (70°F).

Throttle Lever Heating Element

Resistance Measurement

HIGH INTENSITY	YELLOW/BLACK wire BROWN wire	1.96 to 3.64 ohms
LOW INTENSITY	YELLOW/BLACK wire BROWN/YELLOW wire	8.05 to 14.95 ohms

Current Measurement

HIGH INTENSITY	BROWN wire	0.23 Amp. minimum
LOW INTENSITY	BROWN/YELLOW wire	0.13 Amp. minimum

Handlebar Grip Heating Element

Resistance Measurement

HIGH INTENSITY	YELLOW/BLACK wire ORANGE wire	8.73 to ① 10.67 ohms
LOW INTENSITY	YELLOW/BLACK wire ORANGE/VIOLET wire	17.7 to ① 20.7 ohms

① When measuring resistance at terminals the actual value will be half the measurement in table. The reason for that is the elements are connected in parallel. Therefore the total resistance is half the resistance of one element.

TABLE OF CONTENTS

SC-10 SUSPENSION (HP VERSION)	06-02-1
COMPONENT REMOVAL AND INSTALLATION	06-02-2
REMOVAL.....	06-02-4
DISASSEMBLY AND ASSEMBLY	06-02-4
SHOCK ABSORBER INSPECTION	06-02-6
INSTALLATION	06-02-7
RIDE ADJUSTMENT	06-02-7
LUBRICATION	06-02-7

DRIVE AXLE	06-03-1
REMOVAL.....	06-03-2
DISASSEMBLY.....	06-03-2
ASSEMBLY.....	06-03-2
AXIAL PLAY	06-03-4
INSTALLATION	06-03-7
LUBRICATION	06-03-7
ADJUSTMENT	06-03-8

TRACK	06-04-1
TRACK TYPE APPLICATION.....	06-04-1
GENERAL	06-04-1
INSPECTION	06-04-1
REMOVAL.....	06-04-1
INSTALLATION	06-04-1

SC-10 SUSPENSION (HP VERSION)

SC-10 High Performance on Formula III/III LT and Mach 1/Z/Z LT

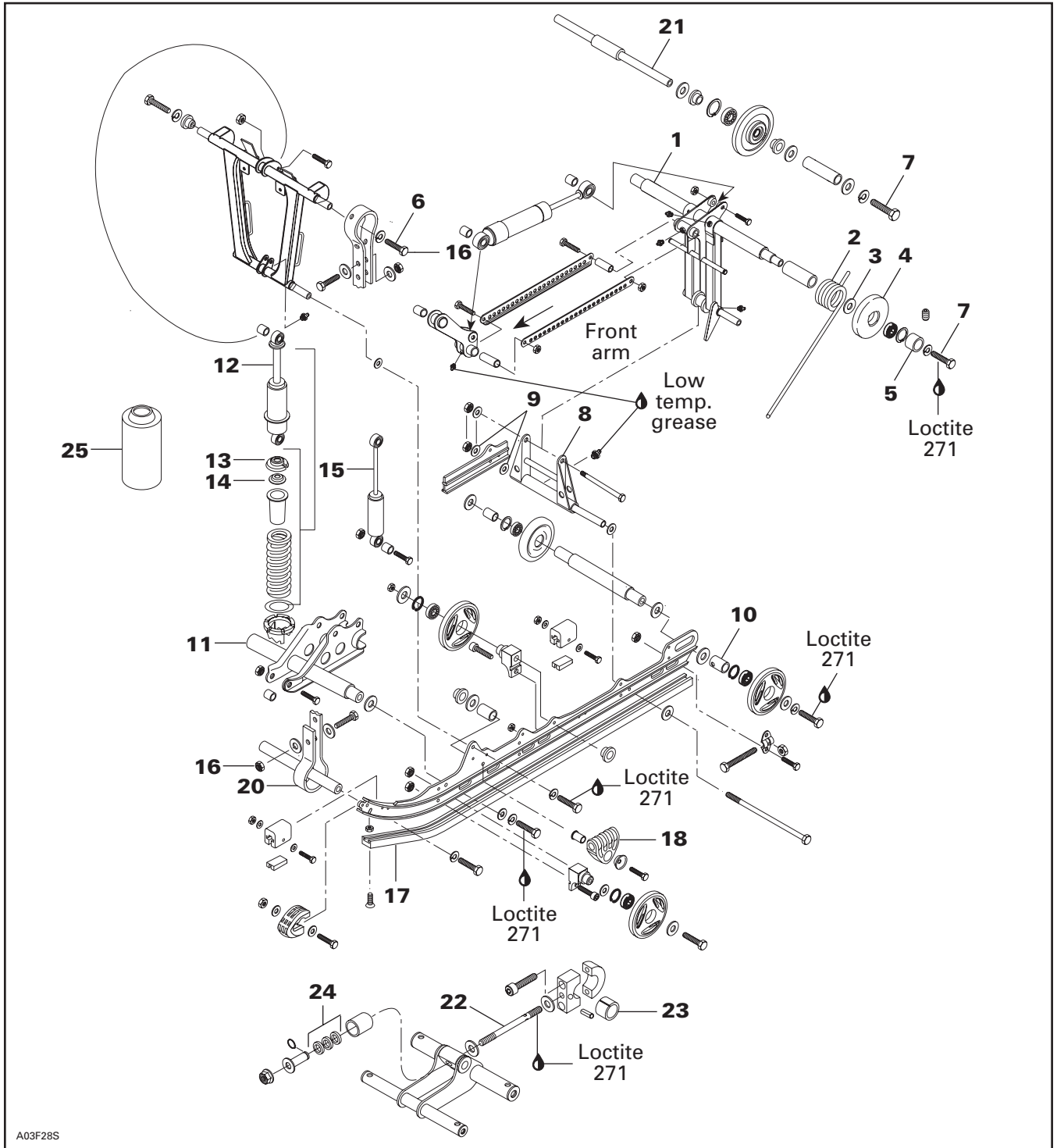

A03F28S

Section 06 REAR SUSPENSION

Sub-Section 02 (SC-10 SUSPENSION (HP VERSION))

COMPONENT REMOVAL AND INSTALLATION

Lift rear of vehicle and support it off the ground.

21, Rear Axle

Completely loosen track tension.

Unscrew one rear idler wheel screw.

Pull out rear axle from opposite side of offset inner wheel. Proceed on either sides for models with 4 wheels on rear axle.

At assembly, temporarily loosen rear shackle lower pivot nut and ACM (Acceleration and Control Modulator) support rear bolt.

Align spacer hole with adjusting bolt.

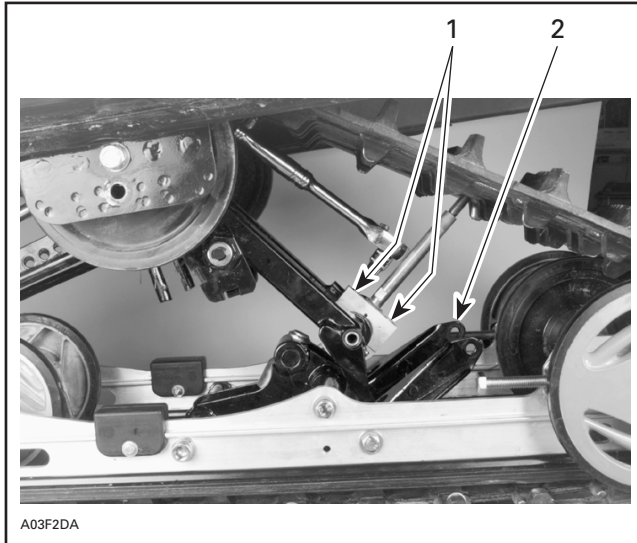

1. Block ass'y Allen screw
2. Schackle

Unscrew block ass'y Allen screws

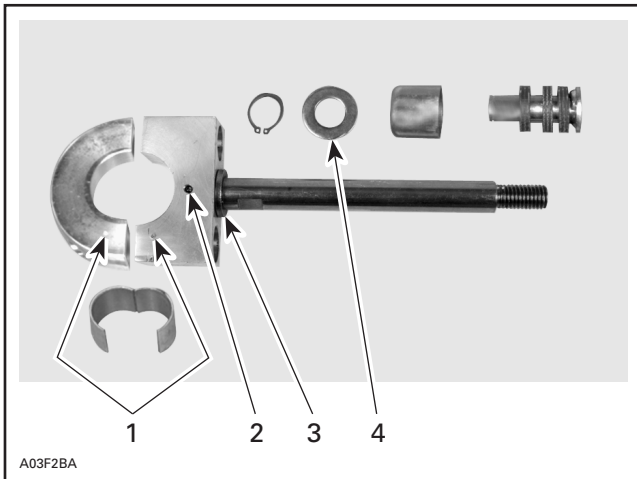

1. Marks
2. Roll pin
3. Smaller washer
4. Larger washer

22, Threaded Rod

TYPICAL

22, Threaded Rod

NOTE: Do not disassemble threaded rod ass'y needlessly.

Lift rear of vehicle.

Unhook rear springs.

Unscrew threaded rod nut.

Remove through bolt from shackle.

Swing shackle rearward.

Collapse suspension in order to disengage threaded rod from its support.

23, Cushion

Separate pivot block.

Remove cushion.

Apply lithium grease on cushion at reassembly.

At assembly, match marked side of both pivot blocks.

When cup is disassembled, it may be too difficult to install circlip before reinstalling this assembly. Install all parts and the circlip loosely around threaded rod. Compress rear of vehicle or lift the front to easily install circlip in its groove.

25, ACM Support

Remove threaded rod ass'y. Loosen rear axle screw on one side and rear shackle screws.

Unbolt ACM support and remove it.

Remove cup.

15, Rear Shock

Lift rear of vehicle.

Slightly turn adjusting cam to expose spring end. Using spring installer (P/N 529 0050 00), remove left spring from adjusting cam.

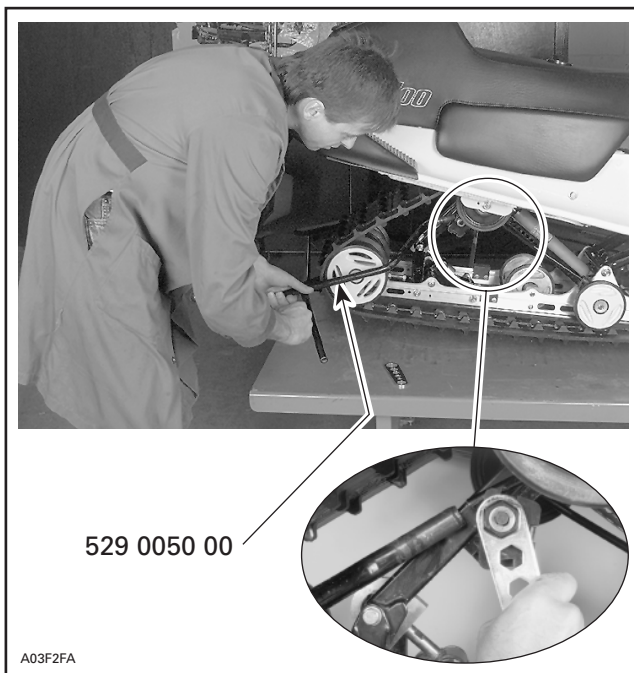

Remove nut on top end of shock.

Remove nut on bottom end of shock. Pry up shock bottom end to ease removing bolt (gas shock only). See installation illustration below.

Installation is reverse of removal procedure. To easily compress gas shock absorber, use a pry bar and locking pliers as a stopper.

▼ CAUTION

Take care not to damage grease fitting.

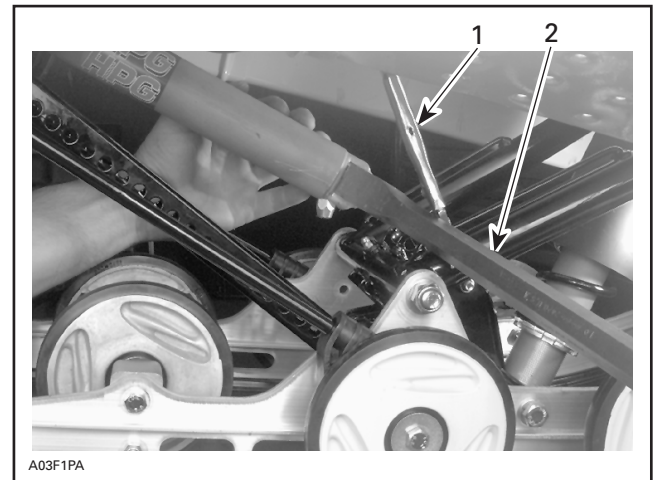

1. Locking pliers
2. Pry bar

12, Front Shock

Unfasten one end of stopper strap.

Unbolt shock and remove it.

2, Rear Spring

Remove spring ends from adjusting cams.

Unbolt rear arm top axle from chassis.

Unscrew set screws from locking ring at each end of top axle.

Remove locking rings and top idler wheels.

Remove springs.

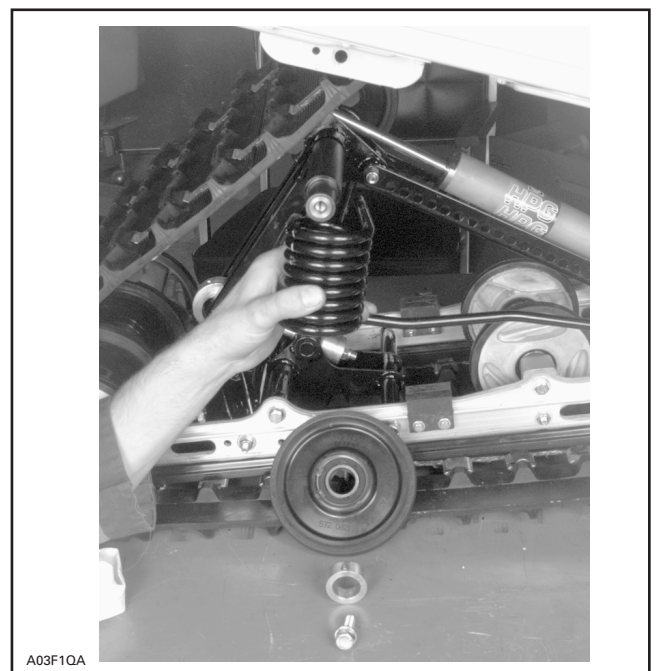

TYPICAL

Section 06 REAR SUSPENSION

Sub-Section 02 (SC-10 SUSPENSION (HP VERSION))

At reassembly, wheel circlip must face outward.

REMOVAL

19, Cam

Decrease spring preload by turning LH cam clockwise and RH cam counterclockwise.

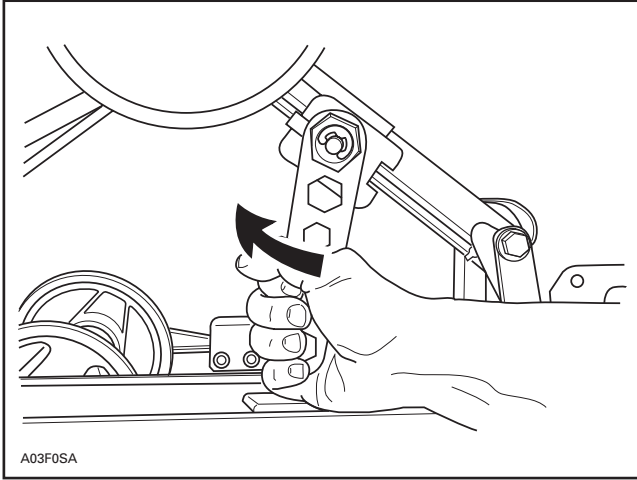

LH SIDE SHOWN

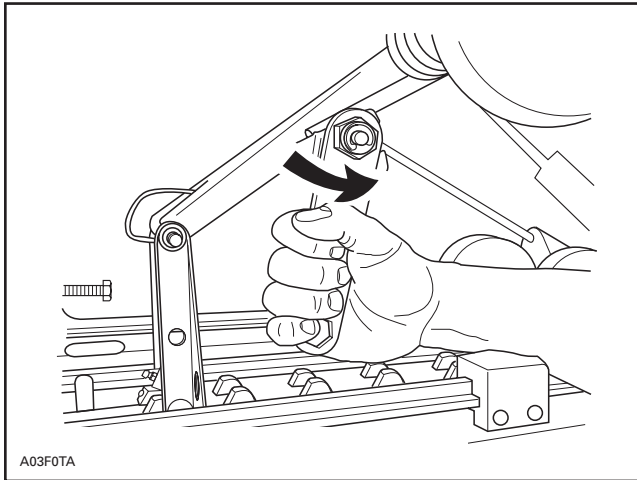

RH SIDE SHOWN

Lift rear of vehicle and support it off the ground.
Loosen track tension.

7, Screw

Unscrew rear arm top axle from chassis.

NOTE: To prevent axle from turning when unscrewing screws assembled with threadlocker, proceed as follows:

- Knock on screw head and/or heat to break threadlocker bond.

- Loosen one screw then retighten.
- Remove the opposite screw.
- Remove the first one.

Unscrew center idler wheel axle from tunnel then remove.

Lift rear of vehicle at least 1 m (3 ft).

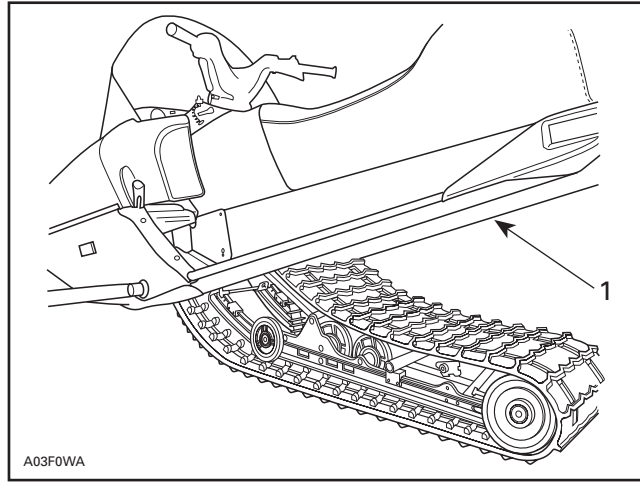

1. At least 1 m (3 ft)

6, Screw

Remove both screws retaining front arm to tunnel.

Remove suspension.

DISASSEMBLY AND ASSEMBLY

Inspect track thoroughly before reinstalling suspension. Refer to TRACK 06-04.

1, Rear Arm

At installation, rear arm stroke limiter must be on rear side.

Section 06 REAR SUSPENSION

Sub-Section 02 (SC-10 SUSPENSION (HP VERSION))

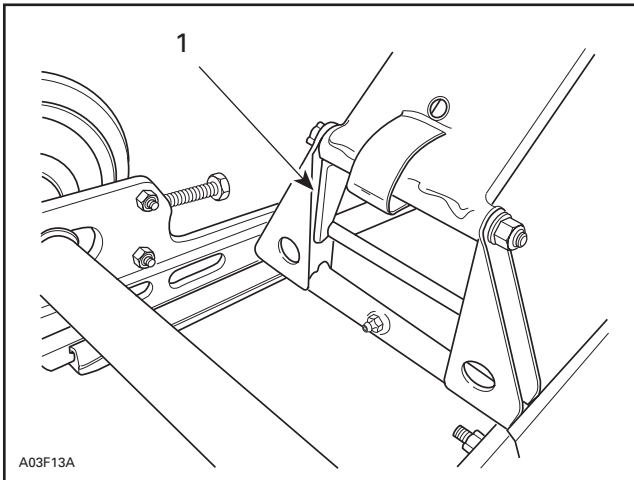

1. Stroke limiter on rear side

8,9, Pivot Arm and Flat Washer

At installation pivot arm grease fitting must face rearward.

10, Outer Bushing

At installation, hole must face adjustment screw.

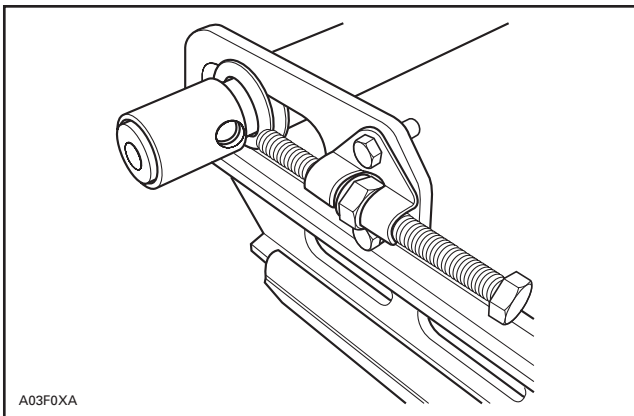

11, Axle

Note position of axles at disassembly. Axles with a paint stripe serve as idler wheel axles. These are more precise than those used as pivot axles. Idler wheel axles can be used as pivot axles but the opposite is not true.

12,13,14, Front Shock, Spring Stopper and Cap

Use shock spring remover (P/N 529 0271 00) in a vise. Mount shock in it and turn shock so that spring coils matched spring compressor.

Close and lock bar. Adjust handle horizontal by changing position of clevis pin.

Push down on handle until it locks. Remove spring stopper and cap then release handle.

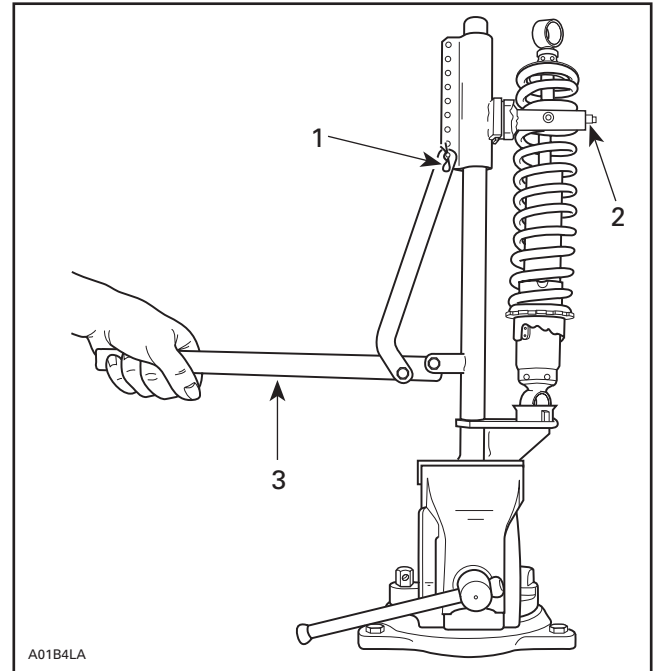

1. Clevis pin
2. Bar
3. Handle horizontal

At installation, cap opening must be 180° from spring stopper opening.

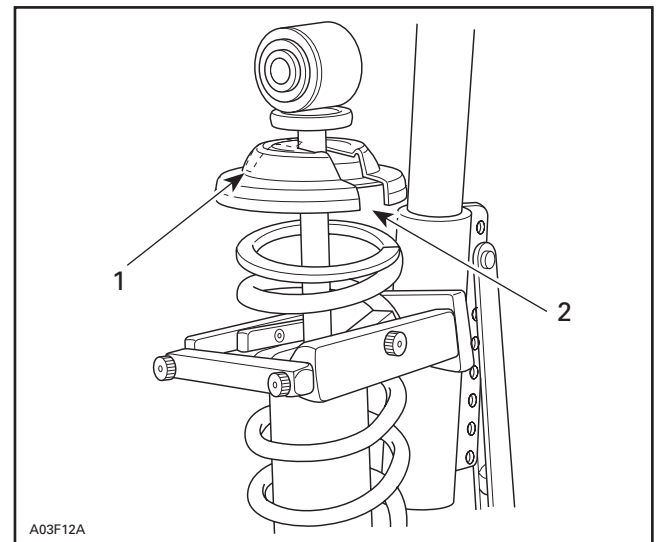

1. Cap opening
2. Spring stopper opening

Section 06 REAR SUSPENSION

Sub-Section 02 (SC-10 SUSPENSION (HP VERSION))

20, Stopper Strap

Inspect strap for wear or cracks, bolt and nut for tightness. If loose, inspect hole for deformation. Replace as required. Make sure it is attached through proper hole from the end. Refer to TECHNICAL DATA 09-03. Torque nut to 11 N•m (97 lbf•in).

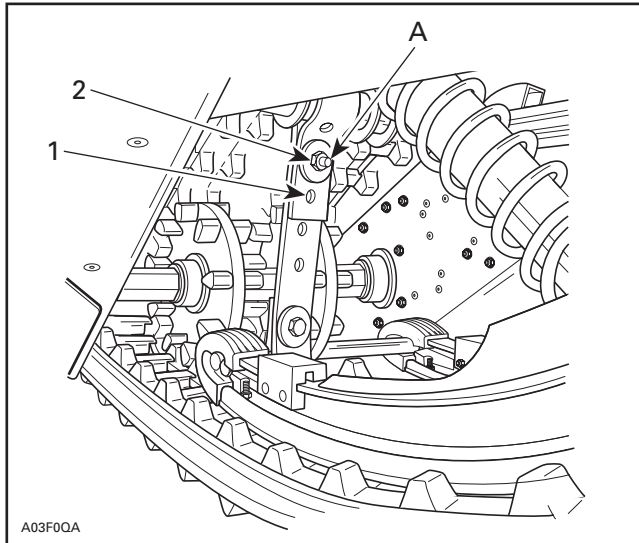

1. 1st hole
2. 2nd hole
- A. 11 N•m (97 lbf•in)

17, Slider Shoe

Replace slider shoes when it is worn to the line.

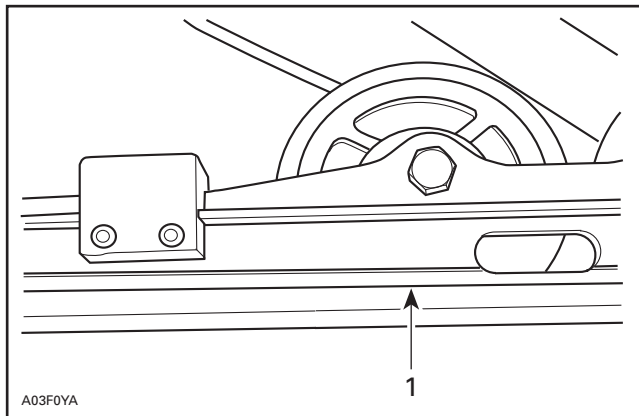

1. Wear limit line

CAUTION

Slider shoes must always be replaced in pairs.

18, Spring Support

CAUTION

To avoid track damage, spring supports must be mounted upward.

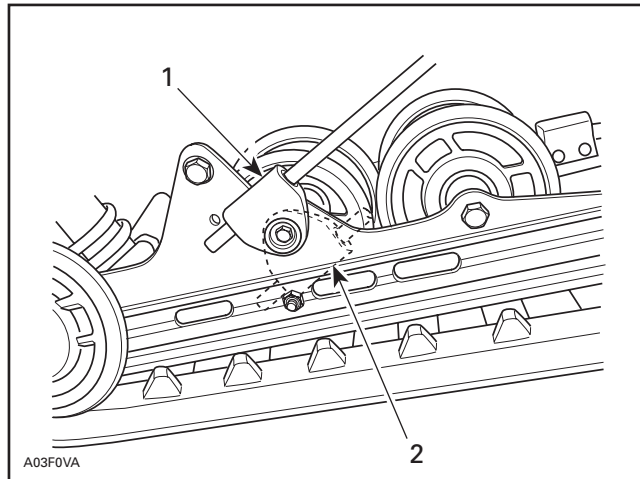

RIGHT SIDE SHOWN

1. Right position: upward
2. Wrong position

SHOCK ABSORBER INSPECTION

Secure the shock body end in a vise with its rod upward.

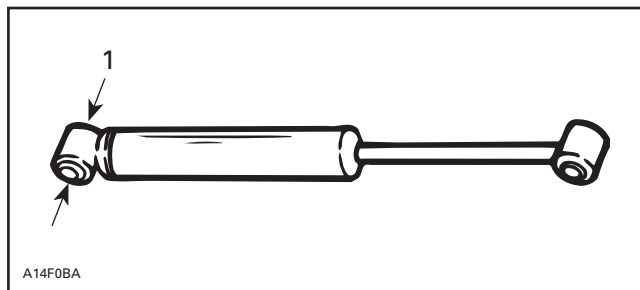

1. Clamp

CAUTION

Do not clamp directly on shock body.

NOTE: Gas pressurized shocks are light gray painted.

Gas shock can be inspected as follows:

Because of gas pressure, strong resistance is felt when compressing shock. When released, the shock will extend unassisted. Renew as required.

Section 06 REAR SUSPENSION

Sub-Section 02 (SC-10 SUSPENSION (HP VERSION))

If suspecting an internal gas leak between oil chamber and gas chamber, check shock as follows:

Install shock in a vise clamping on its bottom eyelet with its rod upward.

Let it stand for 5 minutes.

Completely push down the shock rod then release.

Rod must come out at a steady speed. If speed suddenly increases particularly at end of extension, replace shock.

If suspecting a frozen gas shock proceed as follows:

Place shock in a freezer (temperature below 0°C (32°F)) for 4 hours.

Push down on rod and note its resistance, compare to a new shock. If shock is frozen it will be much more difficult to compress than for the new one.

25, Protector

At assembly, mount protector with its notch toward front.

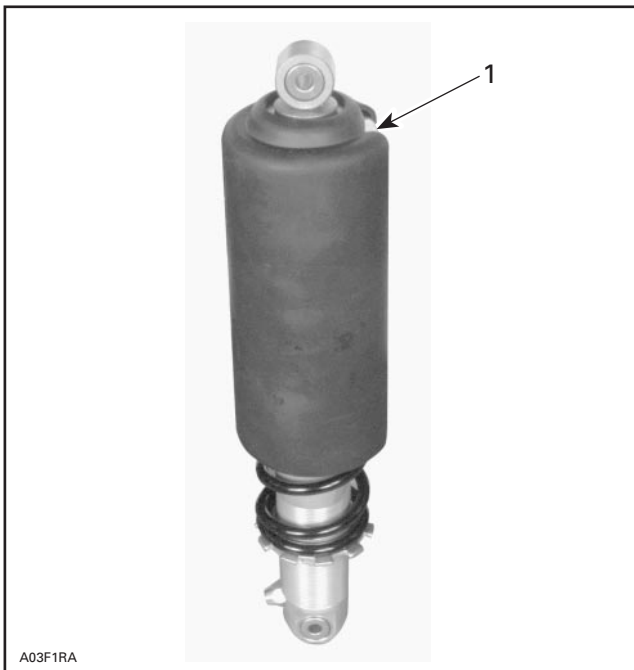

1. Notch

INSTALLATION

Install assembled suspension into track with front portion first.

Insert rear portion of suspension into track.

Bolt front arm, rear arm then center top idler wheel axle.

Adjust track tension.

RIDE ADJUSTMENT

Refer to *Operator's Guide*.

LUBRICATION

Lubricate front and rear arms at grease fittings using low temperature grease (P/N 413 7061 00).

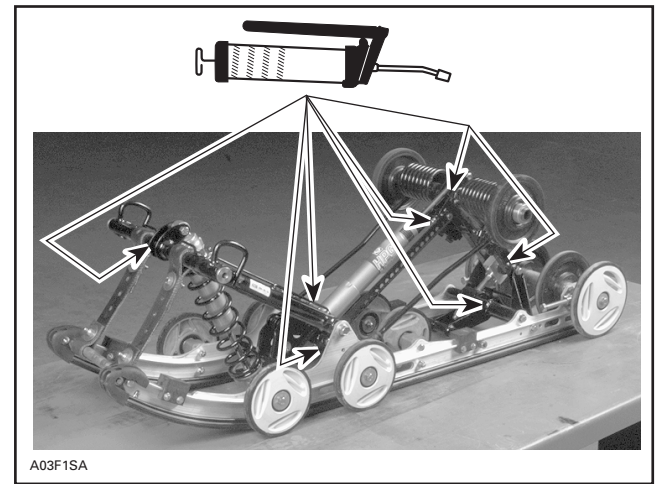

SC-10 HP: 7 GREASE FITTINGS

DRIVE AXLE

F-Series

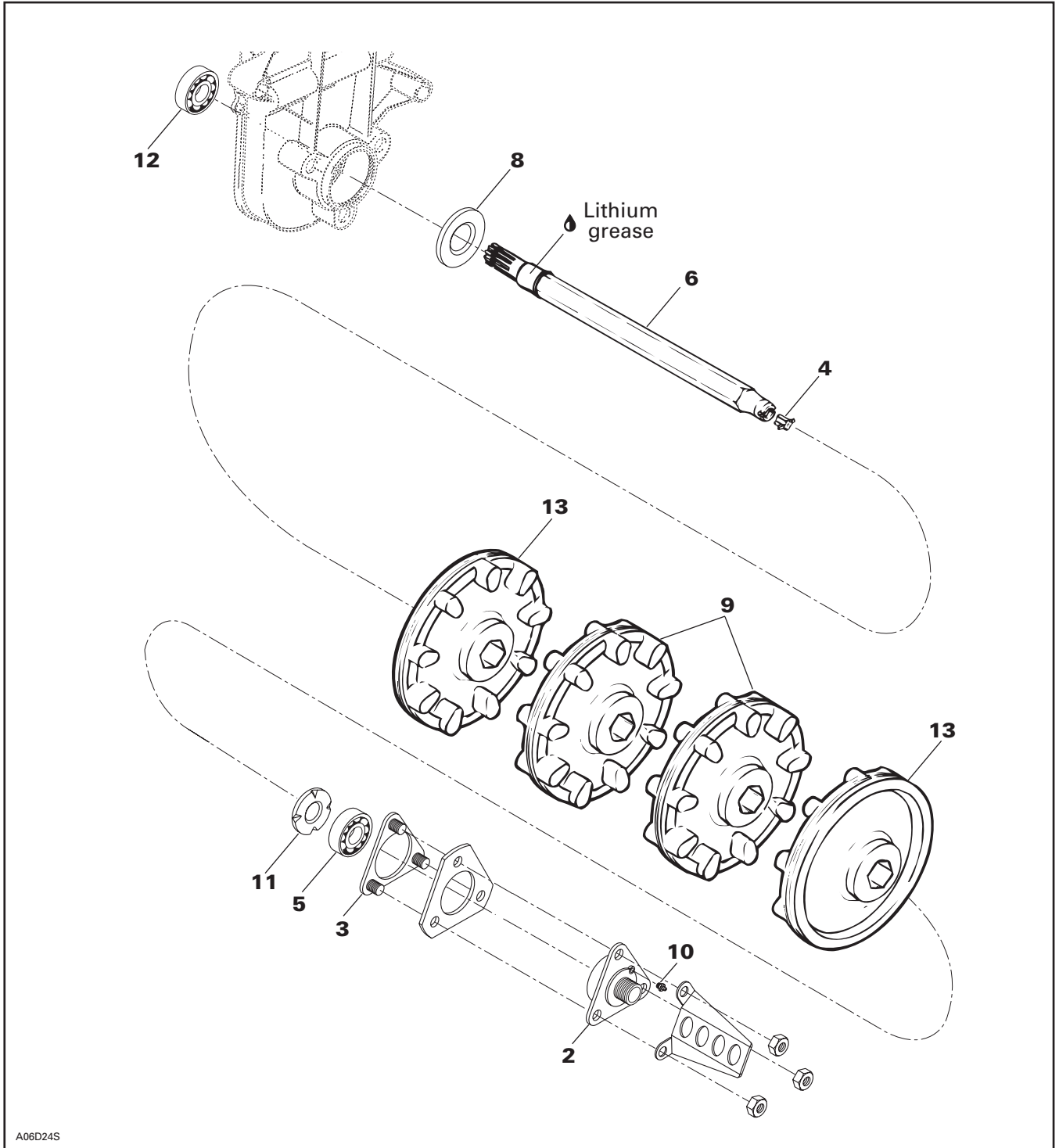

A06D24S

Section 06 REAR SUSPENSION

Sub-Section 03 (DRIVE AXLE)

REMOVAL

Drain oil from chaincase. Release drive chain tension. Remove chaincase cover.

Raise and block rear of vehicle off the ground.

Remove suspension. Refer to SC-10 SUSPENSION 06-02.

2,8, End Bearing Housing and Seal

Remove angle drive unit and coupling cable.

Remove chain and sprocket then circlip and bearing from drive axle.

Pry oil seals from chaincase and end bearing housing.

6,9,13, Drive Axle and Sprocket

Release drive axle sprocket from track and at the same time, pulling the drive axle towards the end bearing housing side.

Remove drive axle from vehicle.

DISASSEMBLY

4, Speedometer Drive Insert

Remove speedometer drive insert.

5,12, Bearing

To remove bearings, use puller assembly, ring and half rings as illustrated.

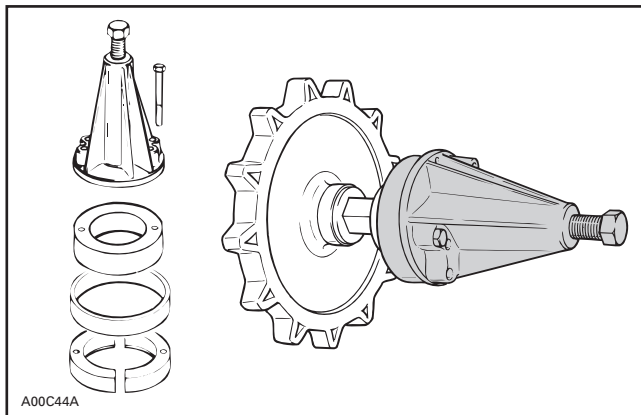

9,13, Sprocket and Half-Sprocket

To remove press fit sprockets, use a press and a suitable support as illustrated.

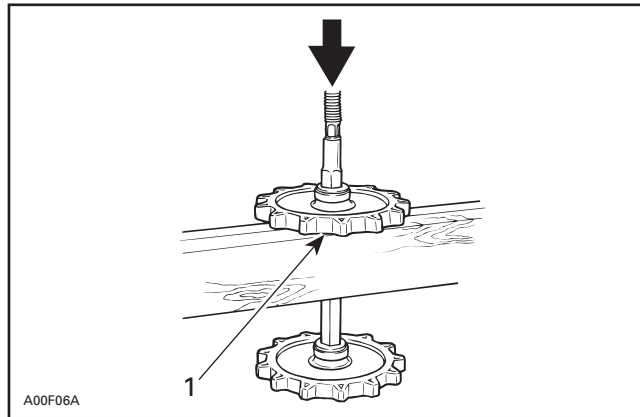

TYPICAL

1. Support sprocket near hub

NOTE: Two different types of sprocket press fit can be found. Ensure to replace ring reinforced sprockets with the same type.

ASSEMBLY

8,9,13, Drive Axle and Sprocket

To assemble press fit sprockets, use a press and a suitable pipe as illustrated. Sprockets must be assembled according to the following dimensions.

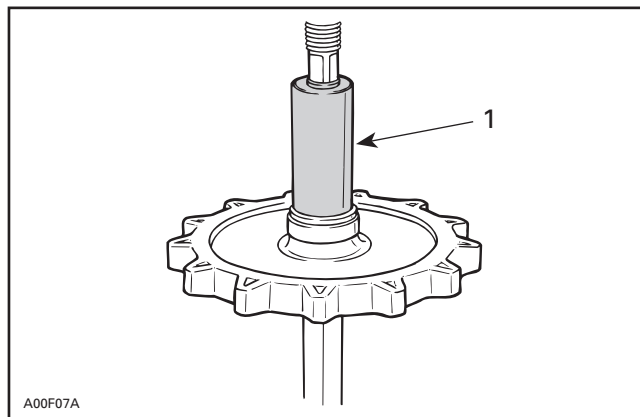

1. Pipe

Section 06 REAR SUSPENSION

Sub-Section 03 (DRIVE AXLE)

F-Series

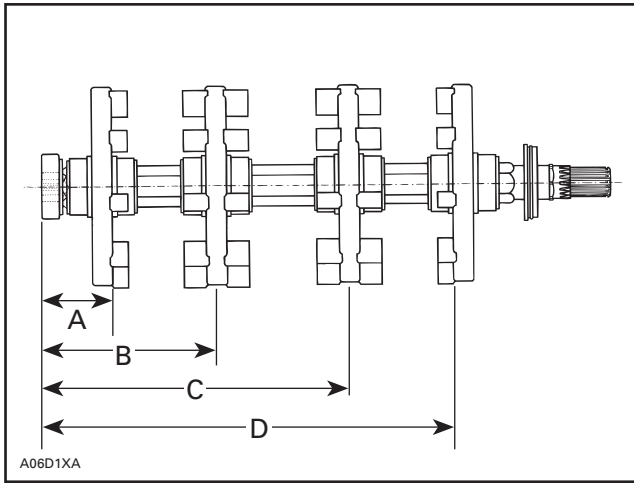

- A. 65.8 mm (2-19/32 in)
- B. 159.3 mm (6-17/64 in)
- C. 282.3 mm (11-7/64 in)
- D. 375.8 mm (14-51/64 in)

Ensure to align indexing marks of each sprocket when assembling.

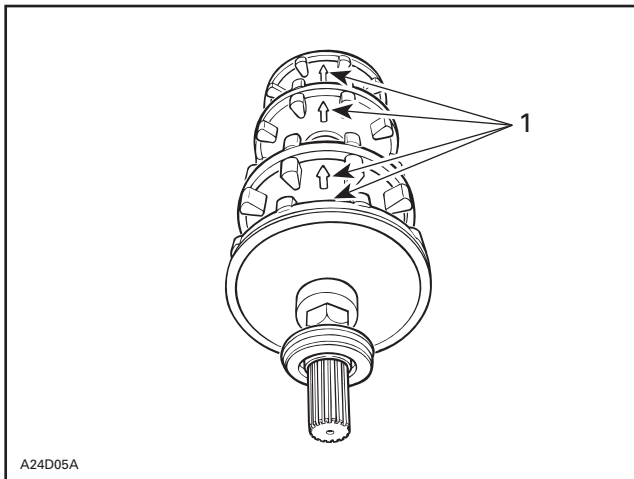

TYPICAL

- 1. Indexing marks aligned

The maximum desynchronization for the sprockets is 1.5 mm (1/16 in).

To check this tolerance, place axle assembly on a plane surface and measure the gap between sprocket tooth and surface.

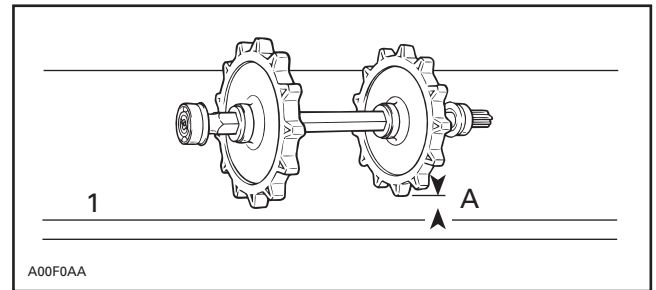

- 1. Plane surface
- A. 1.5 mm (1/16 in) MAXIMUM

CAUTION

The same sprocket must not be pressed twice on the axle. If synchronization is found to be defective, use a new sprocket.

6,8, Drive Axle and Seal

When assembling drive axle, always position a new seal on each end of drive axle (if applicable). Locate seal lip as illustrated.

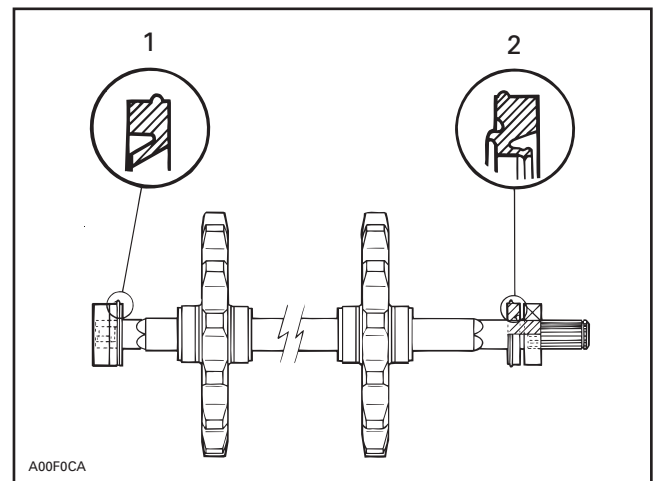

- 1. Grease seal type
- 2. Oil seal type

11, Bearing Protector

At assembly, flat side of bearing protector must be against bearing.

Section 06 REAR SUSPENSION

Sub-Section 03 (DRIVE AXLE)

5,12, Bearing

Always push bearing by inner race.

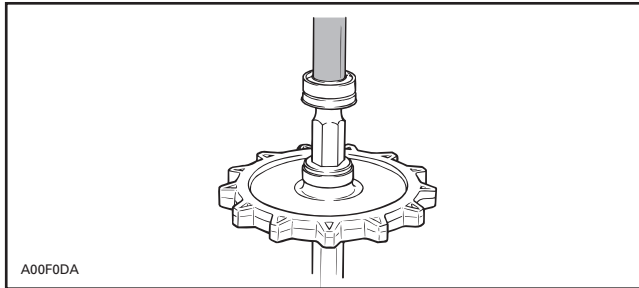

The bearing on the splined side of axle must be pushed until it is seated on shaft shoulder. The end bearing housing bearing must be flush with end of drive axle. Each bearing must have its shield facing the sprocket.

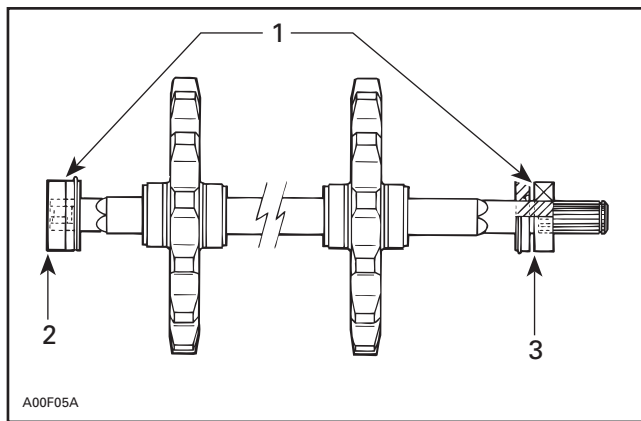

1. Bearing shield on this side
2. Flush with drive axle
3. Seated on shaft shoulder

AXIAL PLAY

F-Series

Ensure there is no deformation of the sheet metal around the end bearing housing. Straighten as required.

Before attempting to adjust the drive axle axial play, check the chaincase perpendicularity as follows:

CHAINCASE PERPENDICULARITY ADJUSTMENT

- Remove driven pulley.
- Slacken bearing collar set screw and working from the driven pulley side, turn bearing collar clockwise.

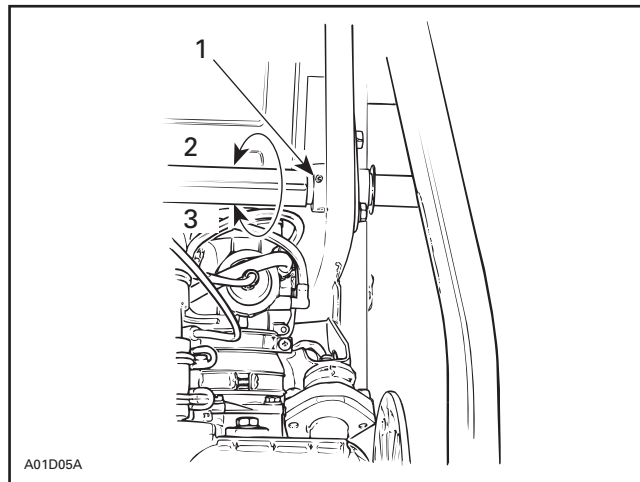

TYPICAL

1. Set screw
2. Slacken
3. Tighten

- Extract bearing from its support.

Wrong chaincase perpendicularity will make it difficult to correctly install the bearing in its support due to the countershaft and support misalignment.

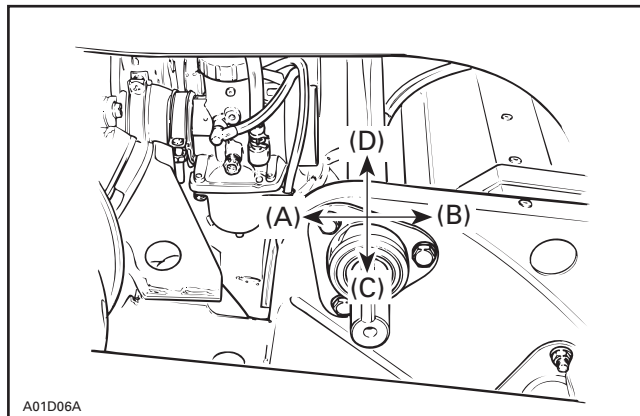

TYPICAL

- Add shim(s) (P/N 504 0398 00) between chaincase and frame to obtain easy bearing installation.

▼ CAUTION

When installing one shim or more between chaincase and frame, secure with 50 mm long screws.

Section 06 REAR SUSPENSION

Sub-Section 03 (DRIVE AXLE)

SHIM LOCATION	BEARING POSITION			
	(A) TOWARD FRONT OF VEHICLE	(B) TOWARD REAR OF VEHICLE	(C) TOWARD BOTTOM OF VEHICLE	(D) TOWARD TOP OF VEHICLE
LOWER	UPPER	UPPER	UPPER	LOWER

This chart can be use as a "starting point" to correct the chaincase perpendicularity.

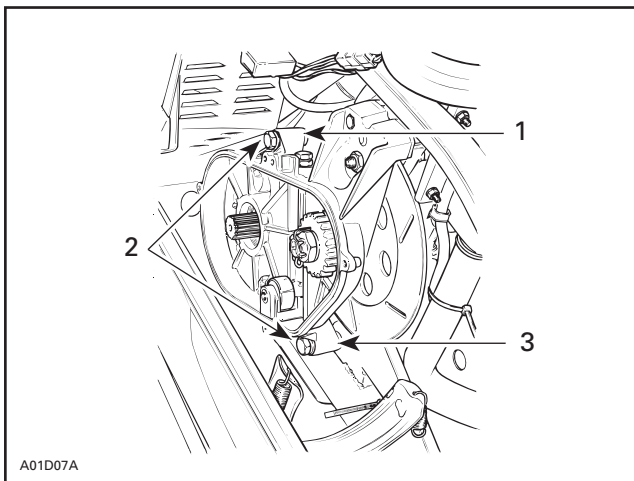

TYPICAL

1. Upper shim location
2. 50 mm long screws when installing one shim or more
3. Lower shim location

– Do not reinstall the driven pulley at this time.

AXIAL PLAY ADJUSTMENT

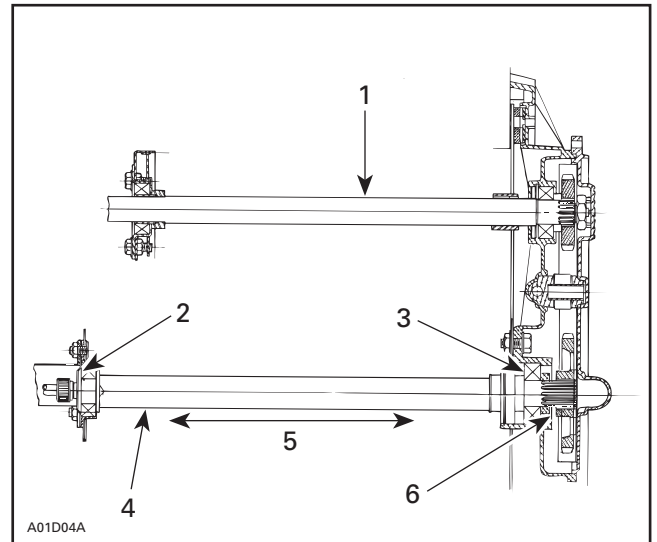

TOP VIEW

1. Countershaft
2. Shim position on end bearing housing side
3. Shim position on chaincase side
4. Drive axle
5. Axial play
6. Shim between sprocket and spacer

– Push the drive axle toward chaincase and take note of the distance between the sprocket and tunnel.

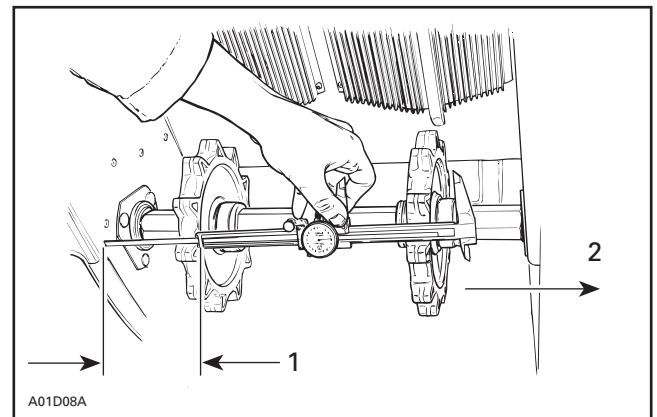

1. Distance between sprocket and tunnel
2. Drive axle pushed toward chaincase

Section 06 REAR SUSPENSION

Sub-Section 03 (DRIVE AXLE)

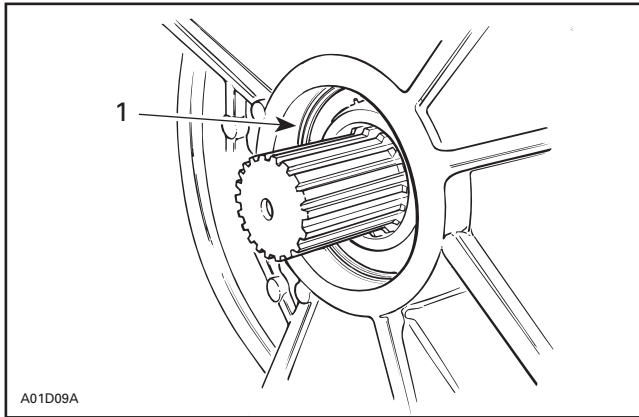

1. No gap all around

- Pull drive axle toward the end bearing housing and take note of the measurement between sprocket and tunnel.

The drive axle axial play is the difference between these 2 measurements.

- Repeat this procedure 2 or 3 times to obtain an accurate measurement.

The allowable drive axle axial play is 0 to 1.5 mm (0 to .060 in).

The drive axle axial play, as calculated above, should be within the allowable axial play, add shim(s) accordingly.

- Remove drive axle, install required shim(s) as per the **shim position** chart, reinstall drive axle without the suspension and track.

SHIM POSITION

Shim position is important to maintain proper sprocket alignment.

▼ CAUTION

Install shim(s) following the pattern shown in the chart.

SHIM(S) REQUIRED	SHIM POSITION AND QUANTITY	
	END BEARING HOUSING SIDE	CHAINCASE SIDE
1	1	
2	1	1
3	2	1

When installing shims between the chaincase and the drive axle bearing, there must be same quantity of shims between the drive chain sprocket and spacer.

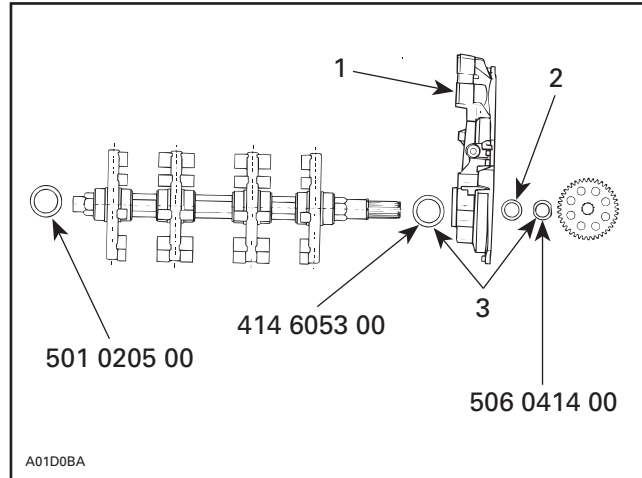

1. Chaincase
2. Spacer
3. Same quantity

- Doublecheck drive axle axial play as described above.
- Modify total shim thickness as required.
- Reinstall track and suspension. Adjust track tension and alignment.

NOTE: Center the track suspension to ensure that the alignment check made in the next step is accurate.

- To center, grasp the track suspension and move it sideways, left and right. Position the track suspension at the midpoint of its sideways movement.
- Check track front alignment by measuring the gap, on each side between guide cleat and the slider shoe, behind the suspension front axle as shown.

Section 06 REAR SUSPENSION

Sub-Section 03 (DRIVE AXLE)

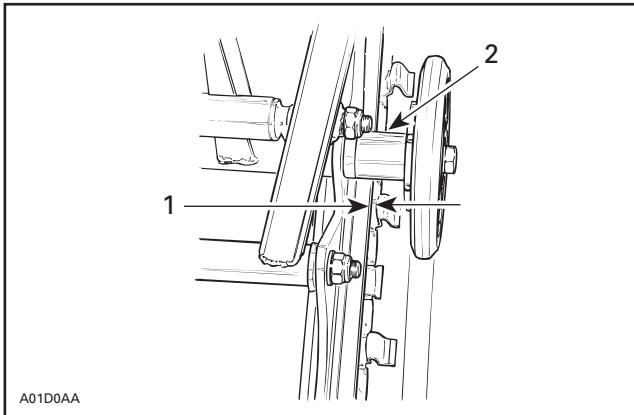

1. Distance between guide cleat and slider shoe
2. Suspension front axle

If the difference between each side exceeds 3 mm (1/8 in), redistribute drive axle shims as follows:

DIFFERENCE BETWEEN EACH SIDE	DRIVE AXLE SHIM REDISTRIBUTION
3 to 4.5 mm (1/8 to 3/16 in)	Remove 1 shim from larger gap side. Add 1 shim on smaller gap side.
4.5 to 6 mm (3/16 to 1/4 in)	Remove 2 shims from larger gap side. Add 2 shims on smaller gap side.

INSTALLATION

4, Speedometer Drive Insert

If the drive axle to be installed is a new part and the vehicle is equipped with a speedometer, a correct size speedometer drive insert must be installed into the axle end. Ensure that insert is flush with end of axle.

Position drive axle assembly into location. Install end bearing housing. Install spacer (if applicable) between bearing and lower chaincase sprocket.

Install chaincase and position seals (if applicable), making sure that a gap of approximately 2 mm (1/16 in) exists between end of bearing housing and each seal.

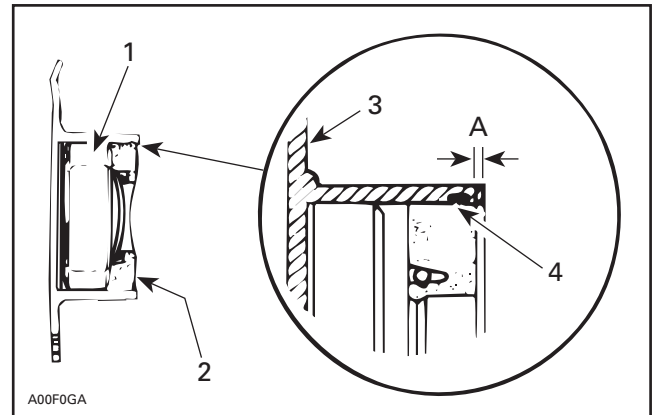

SIDE VIEW

1. Bearing
2. Seal
3. Housing
4. Seal lip
- A. 2 mm approx.

3, Retainer Ring

Make sure that welded nuts are toward inside of tunnel.

Lock drive axle sprocket with a circlip.

Reinstall the chaincase cover.

Refill with chaincase oil. Refer to TECHNICAL DATA 09-03.

Install the suspension. Refer to TRACK 06-04 and adjust track tension and carry out track alignment procedure.

LUBRICATION

15, Grease Fitting

Lubricate end housing bearing with low temperature grease (P/N 413 7061 00).

Section 06 REAR SUSPENSION

Sub-Section 03 (DRIVE AXLE)

ADJUSTMENT

Sprocket/Track Alignment



CAUTION

Do not temper with sprocket/track alignment if frame or suspension is damaged.

Sprockets might be repositioned to fit lugs without removing drive axle.

Use drive axle sprocket adjuster kit (P/N 861 7257 00).

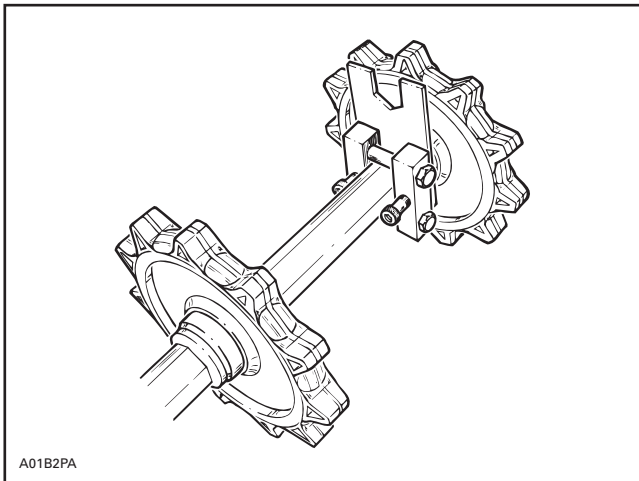

TYPICAL

TRACK

TRACK TYPE APPLICATION

Refer to TECHNICAL DATA section 09-03.

GENERAL

This section gives guidelines for track removal. Some components require more detailed disassembly procedures. In these particular cases, refer to the pertaining section in this manual.

INSPECTION

Visually inspect track for:

- cuts and abnormal wear
- broken rods
- broken or missing track cleats

If track is damaged or rods are broken, replace track. For damaged or missing cleats, replace by new ones, using cleat remover (P/N 529 0287 00). Use small-cleat installer (P/N 529 0085 00).

◆ WARNING

Do not operate a snowmobile with a cut, torn or damaged track.

REMOVAL

F-Series

Remove the following parts:

- speedometer cable
- muffler
- chaincase cover
- suspension
- drive axle seal
- end bearing housing
- sprockets and chain
- drive axle (toward end bearing housing)
- track

INSTALLATION

Reverse the removal procedure.

NOTE: When installing the track, respect rotation direction indicated by an arrow on track thread.

Check sprocket/track alignment as described in DRIVE AXLE 06-03.

Track Tension and Alignment

Track tension and alignment are inter-related. Do not adjust one without checking the other. Track tension procedure must be carried out prior to track alignment.

Tension

Lift the rear of vehicle and support with a mechanical stand. Allow the slide to extend normally. Check the gap half-way between front and rear idler wheels. Measure between slider shoe and bottom inside of track.

When using the track tension gauge (P/N 529 0215 00), slide U shape extrusion to proper deflection.

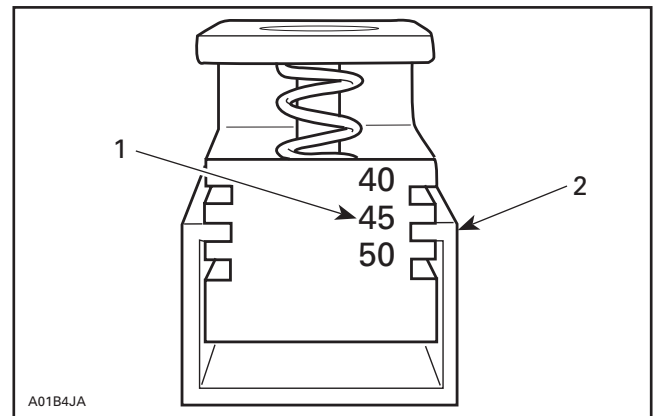

1. Example: 45 mm
2. Extrusion

Insert pre-settled gauge between slider shoe and track. Allow gauge to settle by forcing track up and down. Track tension is as specified when edge of gauge reaches lign.

Section 06 REAR SUSPENSION

Sub-Section 04 (TRACK)

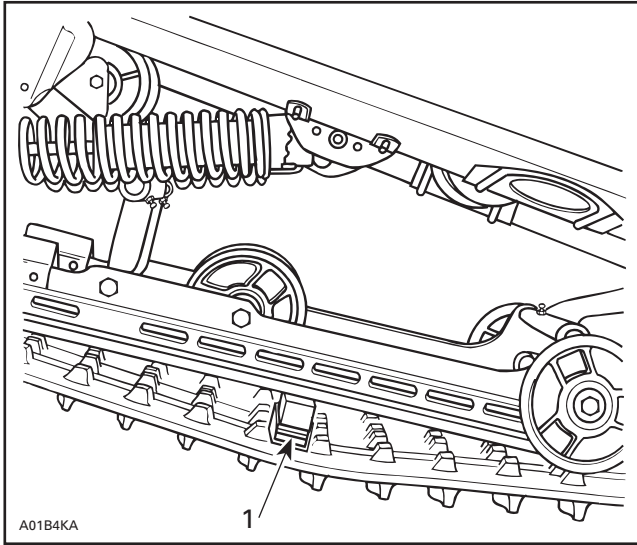

TYPICAL

1. Lign

NOTE: Lightly oil track tension gauge center pin to avoid sticking.

All Models

Refer to TECHNICAL DATA 09-03 for proper tension values.

CAUTION

Too much tension will result in power loss and excessive stress on suspension components. If too loose, the track will have a tendency to thump.

To adjust, loosen the rear idler wheel retaining screws then loosen or tighten the adjuster bolts located on the inner side of the rear idler wheels.

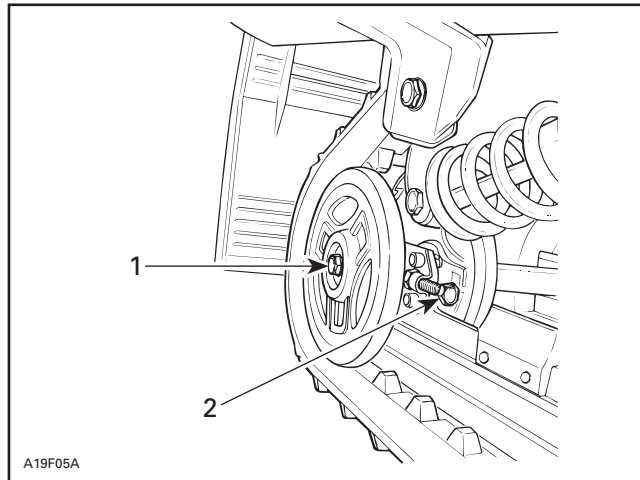

TYPICAL

1. Retaining screw
2. Adjuster bolt

Alignment

WARNING

Before checking track tension, ensure that the track is free of all particles which could be thrown out while it is rotating. Keep hands, tools, feet and clothing clear of track. Ensure no one is standing in close proximity to the vehicle.

All Models

With rear of vehicle supported off the ground, start engine and allow the track to rotate **slowly**.

Check that the track is well centered; equal distance on both sides between edges of track guides and slider shoes.

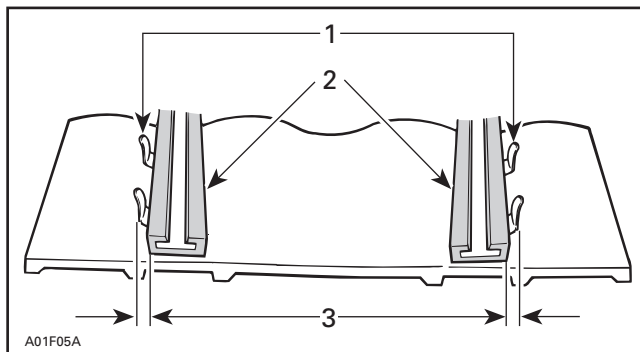

1. Guides
2. Slider shoes
3. Equal distance

◆ WARNING

Before checking track alignment, ensure that the track is free of all particles which could be thrown out while track is rotating. Keep hands, tools, feet and clothing clear of track.

To correct, stop engine then tighten the adjuster bolt on side where guides are farthest to slide. Re-check alignment.

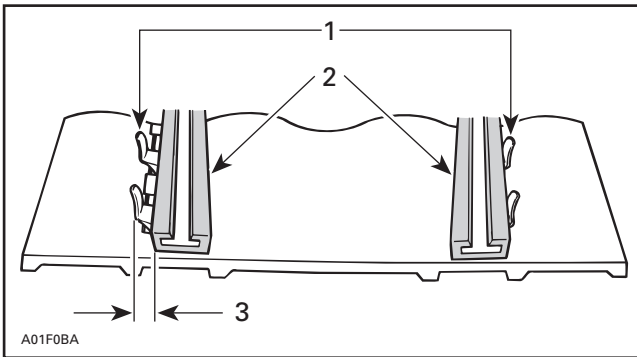

- 1. Guides
- 2. Slider shoes
- 3. Tighten on this side

NOTE: Torque retaining screw to 48 N•m (35 lbf•ft) after adjustment.

Tighten the idler wheel retaining screws.

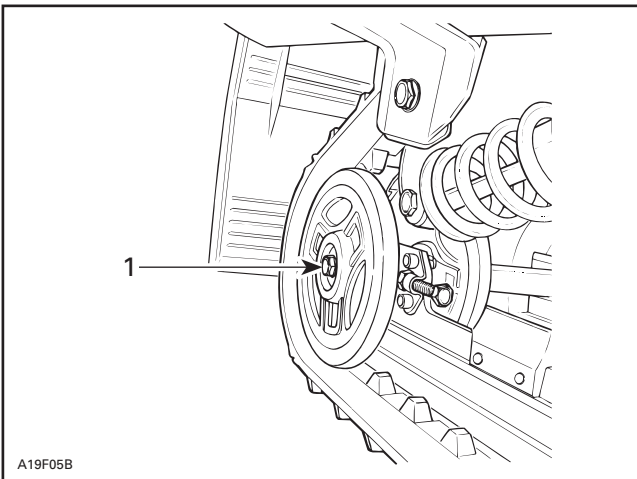

TYPICAL

- 1. Retighten

Restart engine, rotate track **slowly** and recheck alignment.

Track Cleat

Removal

- Raise rear of vehicle off the ground and lift snowguard then rotate track to expose a cleat to be replaced.
- Using track cleat remover (P/N 529 0087 00) for all models.

Installation

NOTE: Keep the same pitch between guide cleats.

- Place new cleat in position and using small track cleat installer (P/N 529 0085 00) bend cleat then push tabs into rubber.

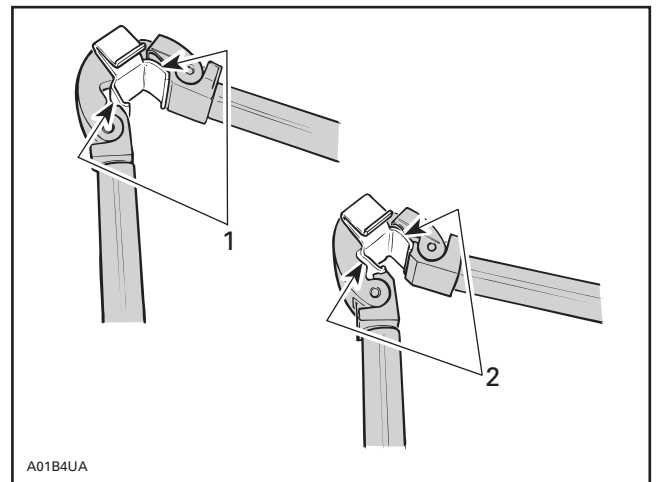

TYPICAL

- 1. First step
- 2. Second step (to push tabs into rubber)

TABLE OF CONTENTS

STEERING SYSTEM	07-02-1
INSPECTION	07-02-2
DISASSEMBLY AND ASSEMBLY	07-02-2
INSPECTION	07-02-3
ADJUSTABLE HANDLEBAR	07-02-4
STEERING ADJUSTMENT (SKIS)	07-02-5
LUBRICATION	07-02-7

SUSPENSION AND SKI SYSTEM	07-03-1
DISASSEMBLY	07-03-2
INSPECTION	07-03-3
INSTALLATION	07-03-3

STEERING SYSTEM

F-Series

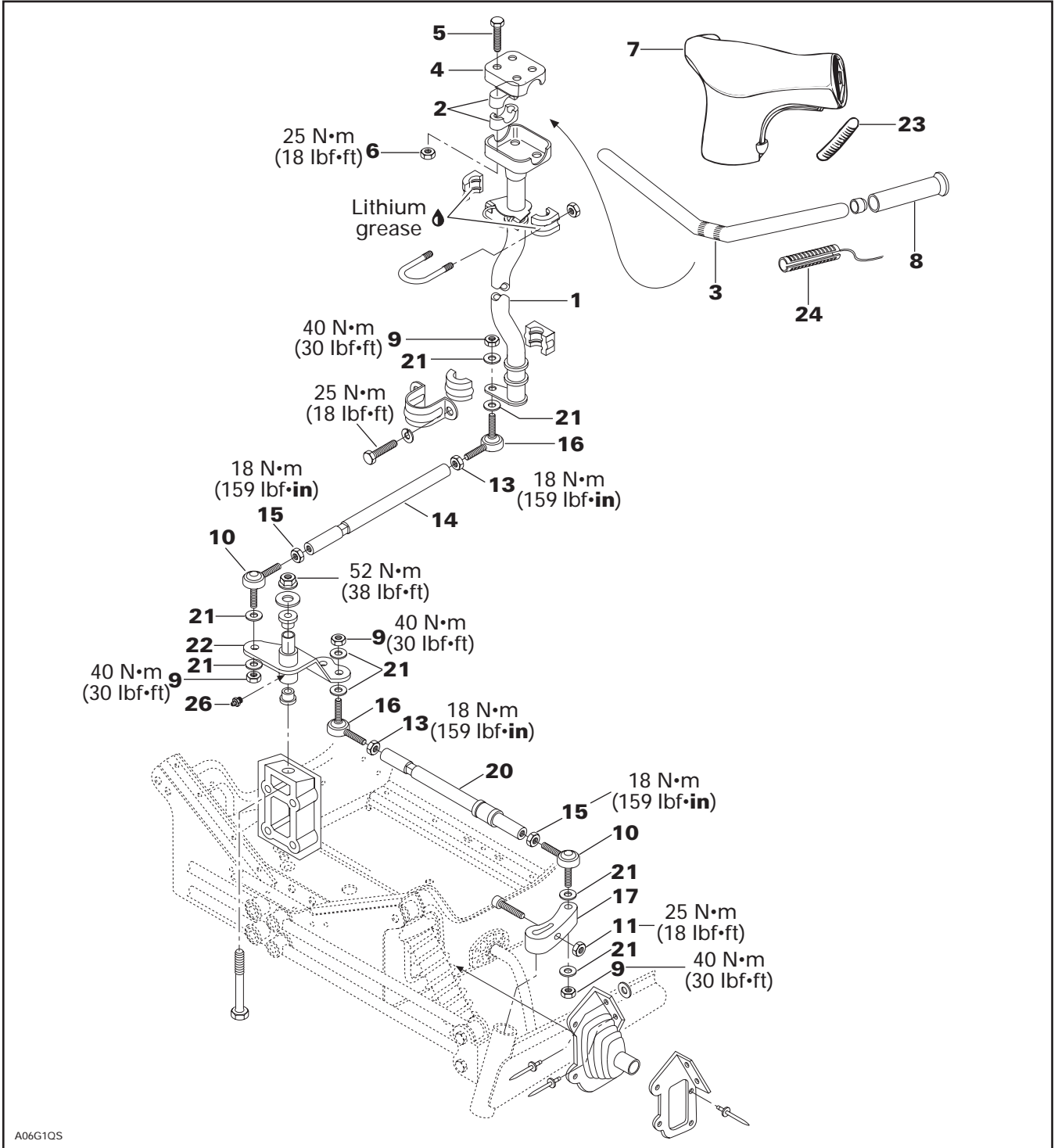

A06G1QS

Section 07 STEERING/FRONT SUSPENSION

Sub-Section 02 (STEERING SYSTEM)

INSPECTION

Check skis and runner shoes for wear, replace as necessary. (Refer to FRONT SUSPENSION 07-03).

17, Steering Arm and Ski Leg

Make sure steering arm and ski leg splines interlock.



WARNING

Any parts having worn splines have to be replaced with new ones.

Check the general condition of the steering system components for wear. Replace if necessary.

DISASSEMBLY AND ASSEMBLY

8, Grip

Grips can be removed and installed without any damage by injecting compressed air into the handlebar or by heating them with a heat gun.

1, Steering Column

Remove steering pad then handlebar ass'y.

To gain access remove the air intake silencer and carburetors.

Detach the short tie rod (under the engine) from the steering column.

17, Steering Arm

To maintain correct steering geometry for reassembling, punch mark the steering arm and ski leg before disassembly.

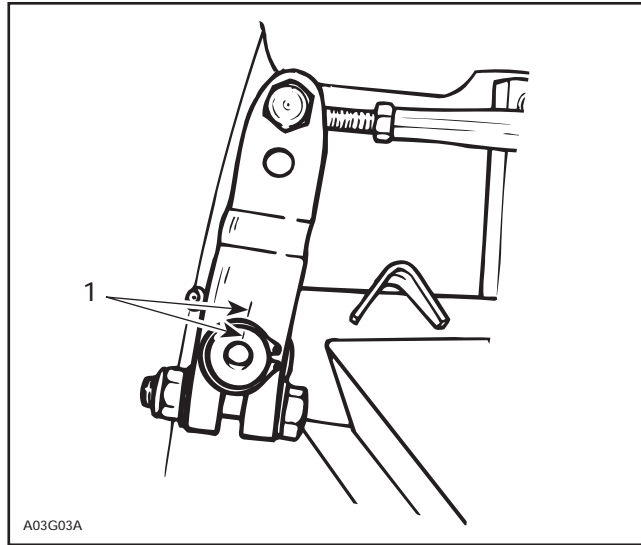

TYPICAL

1. Punch marks

24, Heating Grip Element

The grips might be unremovable as explained above, in this case, carefully proceed as follows to prevent damaging the heating elements.

Locate the element wires inside the handlebar; look through end of grip. Start cutting the grip exactly opposite the element wires and immediately peel it open to locate the gap in the heating element, as shown.

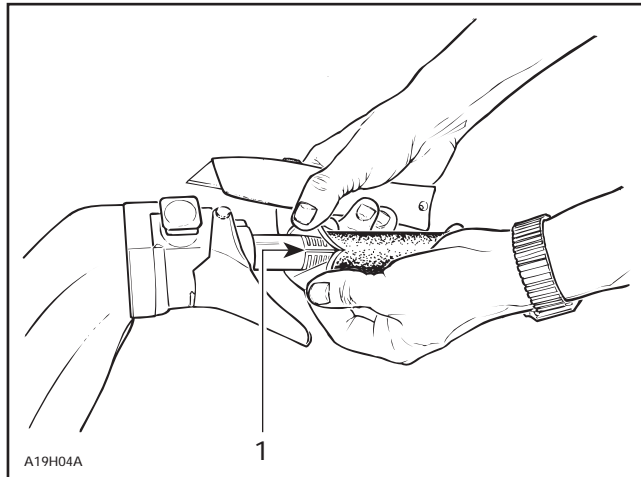

1. Gap in the heating element opposite the wires

Continue cutting along the gap and remove the grip. If required, slowly peel heating element from handlebar and remove it.

Section 07 STEERING/FRONT SUSPENSION

Sub-Section 02 (STEERING SYSTEM)

To install, stick the heating element to the handlebar making sure the wires do not interfere with operation of the accelerator or brake handle.

◆ WARNING

Never use lubricants (e.g. soap, only grease, etc.) to install the handlebar grip, use a mix of soap and water. Mix 40 parts of water with one part of dish washing soap (recommended: Ultra Joy, Sunlight or Palmolive).

Heat the grip with a heater gun or a spot light to ease installation. Insert new grip with a rubber mallet.

INSPECTION

24, Heating Grip Element

Refer to TESTING PROCEDURE 05-06.

10,16, Ball Joint (Left Hand and Right Hand Threads)

Inspect ball joint ends for wear or looseness, if excessive, replace them.

Screw threaded end of the ball joint into the tie rod. The maximum external threaded length not engaged in the tie rod must not exceed the value L in the following thread length chart:

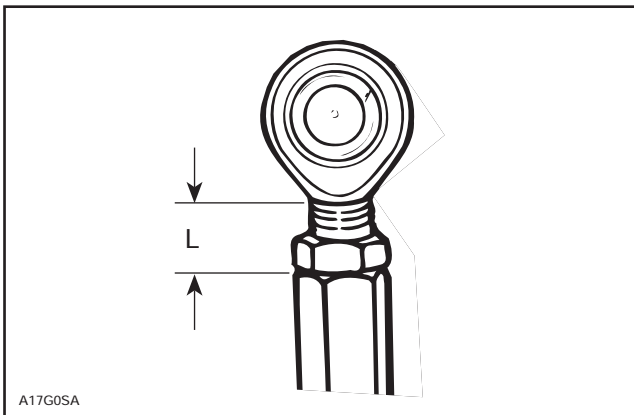

TYPICAL

MODEL	L	
	mm	(in)
All	20	(25/32)

The ball joint should be restrained when tightening the tie rod end lock nut. Align it so the tie rod end is parallel to the steering arm when assembled on the vehicle, refer to the following illustration.

For proper torque specifications refer to the specific exploded view for the vehicle being serviced.

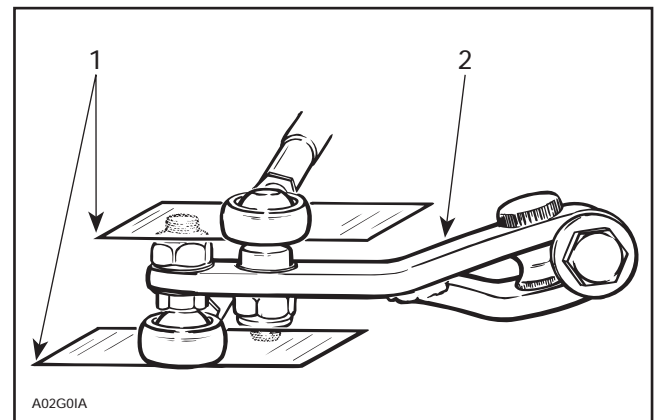

TYPICAL

1. Parallel with steering arm
2. Steering arm

◆ WARNING

The cut off section of the ball joint must run parallel with the steering arm. When tightening lock nuts, restrain ball joint with appropriate size wrench. Ensure not too many threads are kept outside of the tie rod according to the thread length chart.

Section 07 STEERING/FRONT SUSPENSION

Sub-Section 02 (STEERING SYSTEM)

21, Hardened Washer

Install a hardened washer on each side of the arm.

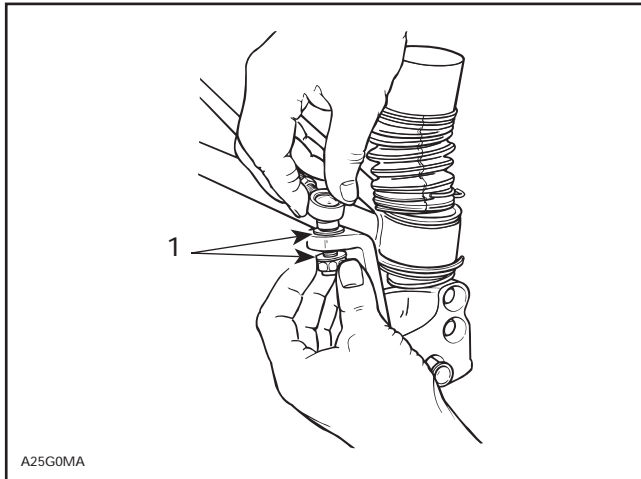

TYPICAL

1. Hardened washers

17, Steering Arm

The steering arm angles should be equal on both sides when skis are parallel with vehicle.

Steering arm must run parallel to ski.

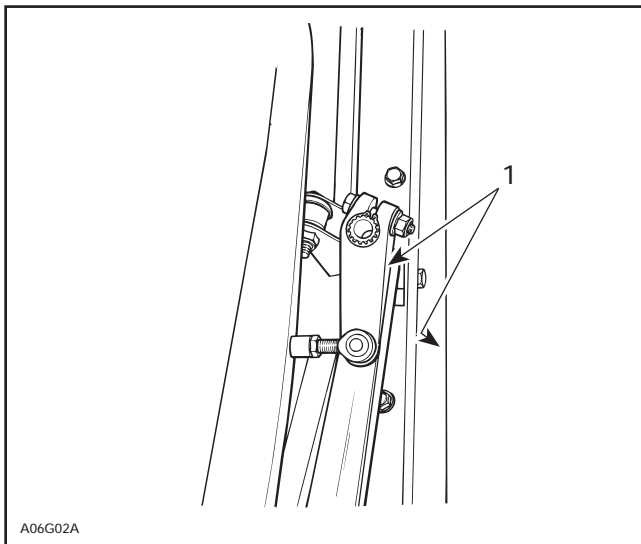

TYPICAL

1. Parallel

Tighten the steering arm pinch bolt to the torque specified in the exploded view.

9,13,15, Ball Joint Nut and Jam Nut

Tighten ball joint, nuts and jam nuts to specified torque (see exploded view).

11,12, Steering Arm Nut and Bolt

Tighten steering arm nuts to specified torque (see exploded view).

ADJUSTABLE HANDLEBAR

1,3, Steering Column and Handlebar

If applicable, remove the steering clamp and nuts holding the handlebar to the steering column.

2,4,5,6, Handlebar Support, Steering Clamp, Bolt and Nut

Install the handlebar support, steering clamp, the 4 screws and nuts to the column, as illustrated.

See applicable exploded view.

Adjust the steering handlebar to the desired position.

Lock the handlebar in place by tightening the 4 nuts as specified in the illustrations.

▼ CAUTION

Tighten the nuts equally in a criss-cross sequence and ensure there is an equal gap on each side of the clamps.

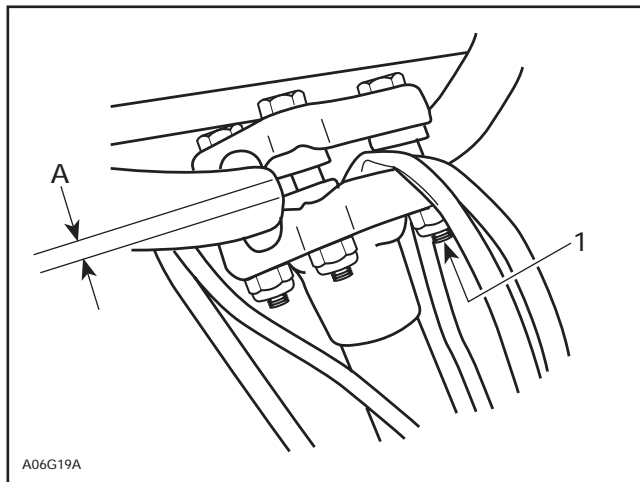

TYPICAL

1. Torque to 26 N•m (19 lbf•ft)

A. Equal gap all around

◆ WARNING

Avoid contact between the brake handle and the windshield by NOT adjusting the handlebar too high.

Section 07 STEERING/FRONT SUSPENSION

Sub-Section 02 (STEERING SYSTEM)

◆ WARNING

Make sure that the steering pad and all controls are properly fixed to their normal location on the handlebar.

7,23, Steering Pad and Rubber Attachment

▼ CAUTION

Prior to installation, perform handlebar adjustment.

Properly fit the steering pad to the handlebar. Assemble using the 2 rubber attachments.

◆ WARNING

Make sure that the steering pad and all controls are properly fixed to their normal location on the handlebar.

STEERING ADJUSTMENT (SKIS)

Definitions

TOE-OUT:

A difference measured between the front edge of the skis "A" and rear edge "B" as viewed from the top. It is adjustable.

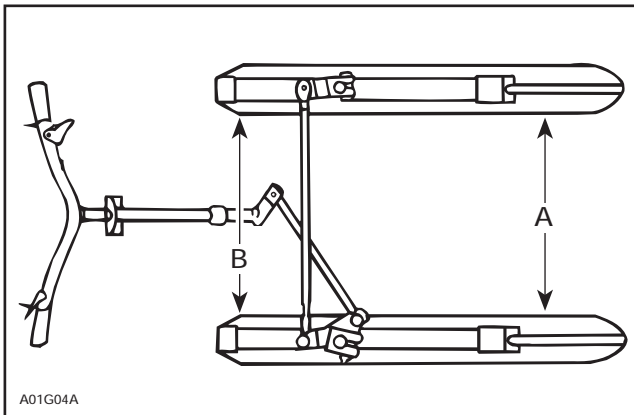

CAMBER:

A specific inward or outward tilt angle of ski leg compared to a vertical line when viewing the vehicle from front.

Adjustments

Adjustments should be performed following this sequence:

- Pivot arm centering.
- Set camber angle.
- Check for a horizontal handlebar.
- Set toe-out.

DSA System

PIVOT ARM CENTERING

◆ WARNING

Do not attempt to adjust straight ahead ski position by turning the ball joint on tie rod **no. 14**.

13,14,15,22, Jam Nut, Tie Rod and Pivot Arm

With handlebar in straight ahead position, the center of the pivot arm must be in line with the end of the bolt. Loosen the jam nuts on tie rod **no. 14** (LH threads on steering column end) and turn tie rod accordingly. Align and retighten the jam nuts to 18 N•m (159 lbf•in).

◆ WARNING

Never lengthen tie rod so that threaded portion of ball joint exceeds 20 mm (25/32 in).

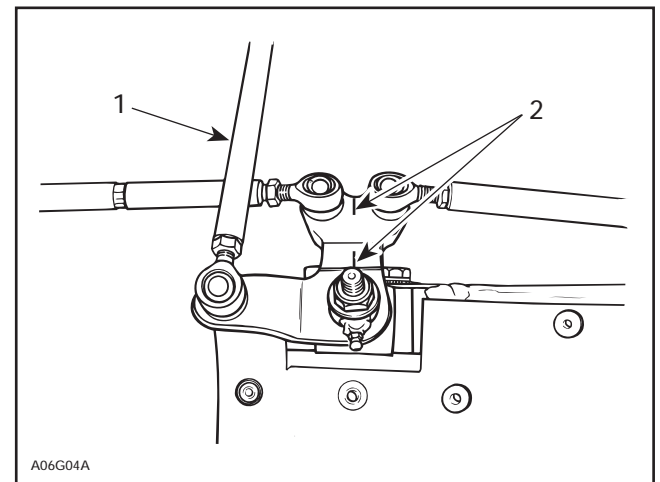

1. Tie rod no. 14
2. Center of pivot arm in line with bolt end

Section 07 STEERING/FRONT SUSPENSION

Sub-Section 02 (STEERING SYSTEM)

CAMBER

NOTE: On vehicles without adjustable radius arms (no. 7) the camber is not adjustable.

NOTE: Identical adjustments are required on both sides of the vehicle.

- Make sure the vehicle is leveled by placing an angle finder under the main frame member as shown on the following illustration.

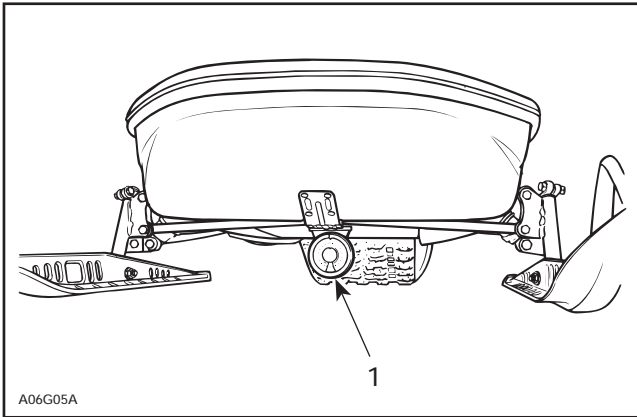

1. Angle finder

Using special tool (P/N 529 0216 00) mounted to the ski leg position the angle finder on the tool as shown in the following illustration. An alternate location for the angle finder if the special tool is not available is the outside of the ski leg housing.

Adjust the camber to $0^\circ \pm 0.5^\circ$.

▼ CAUTION

Angle finder must sit square against swing arm. Positioning angle finder against weld bead or decal may result in false reading.

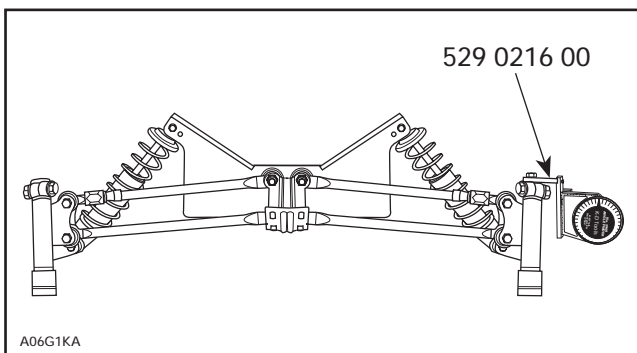

TYPICAL — CAMBER ADJUSTMENT SET-UP

Adjusting

- Loosen lock nut on both lower control arms.

- Unbolt both upper control arms at ski leg housing. Turn tie rod half turn at a time to obtain a vertical ski leg ($0^\circ \pm 0.5^\circ$). Bolt upper control arms.

HANDLEBAR AND SKI TOE-OUT

Check that handlebar is horizontal when skis are in straight ahead position by measuring from the extremities of the grips to the rearmost edge of the tunnel, as shown.

NOTE: The reference point must be the same relative to each side.

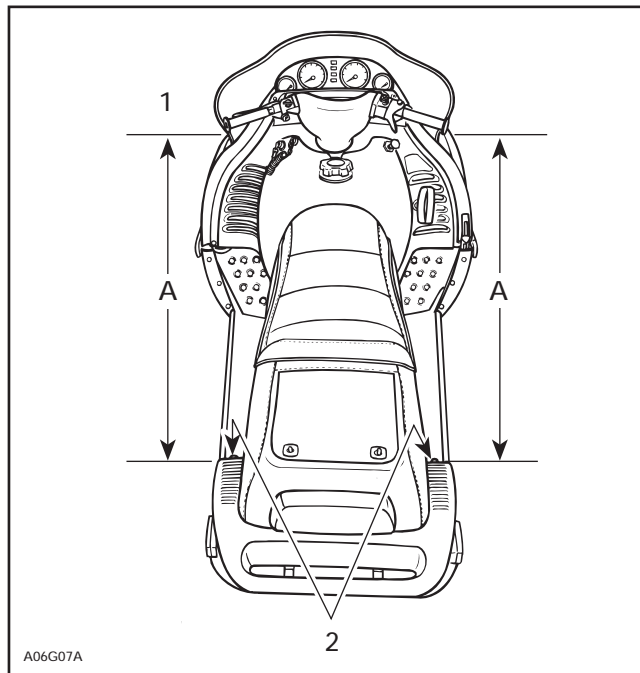

TYPICAL

1. Equal distance A on each side
2. Same reference point (rivet)

Adjustment is performed by adjusting length of left and right tie rods no. 20.

◆ WARNING

Do not attempt to adjust skis straight ahead position by turning ball joint on tie rod no. 14.

Procedure:

- Loosen jam nuts no. 13 and no. 15 of both tie rods no. 20.
- Turn the tie rod on one side to shorten its length.

Section 07 STEERING/FRONT SUSPENSION

Sub-Section 02 (STEERING SYSTEM)

- Lengthen the other one by turning it exactly the same amount, so that toe-out is not changed.

◆ WARNING

Never lengthen tie rod so that threaded portion of ball joint exceeds 20 mm (25/32 in).

- Close front of skis manually to take all slack from steering mechanism.

NOTE: A rubber cord must be hooked in front of skis to keep them closed.

Toe-out is 0 mm (0 in) when skis are in a straight-ahead position and the front of vehicle is lifted off the ground.

NOTE: To make sure skis are in a straight-ahead position, place a straight edge against pre-adjusted track and measure the distance between front and rear of skis and straight edge. Distances should be equal. After the ski toe-out adjustment, distance must be equal.

To reduce tolerance when measuring, set one ski to proper toe-out then measure from that ski to the opposite ski.

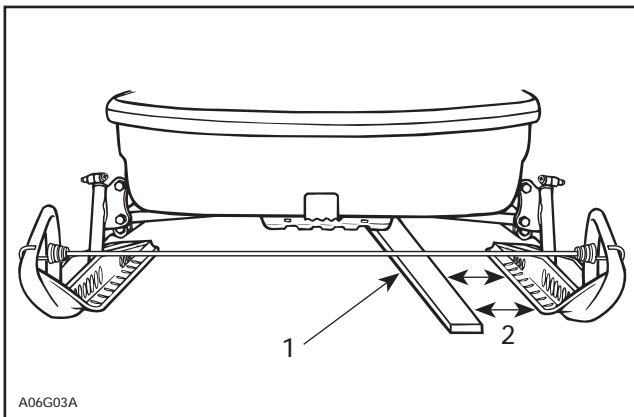

TYPICAL

1. Straight edge
2. Measure here

LUBRICATION

◆ WARNING

Do not lubricate throttle cable or housing.

26, Grease Fittings

Only use low temperature grease (P/N 413 7061 00).

The following symbols will be used to show what type of lubricant should be used at the suitable locations.

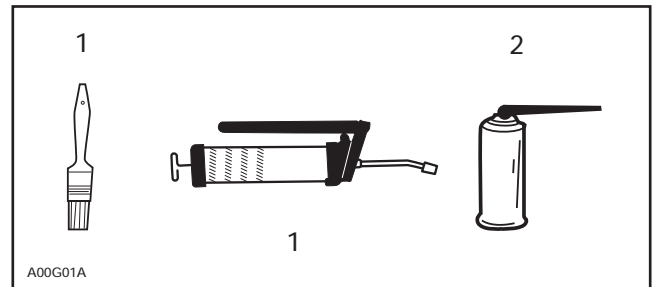

1. Low temperature grease
2. Penetrating lubricant (P/N 293 6000 16)

Lubricate:

- Steering column.
- Upper and lower control arms drop link and tie rod ends.
- Grease ski legs, ski pivots and idler arm.
- Coat stabilizer sliders with grease, and oil their ball joints if so equipped.

Section 07 STEERING/FRONT SUSPENSION

Sub-Section 02 (STEERING SYSTEM)

F-Series

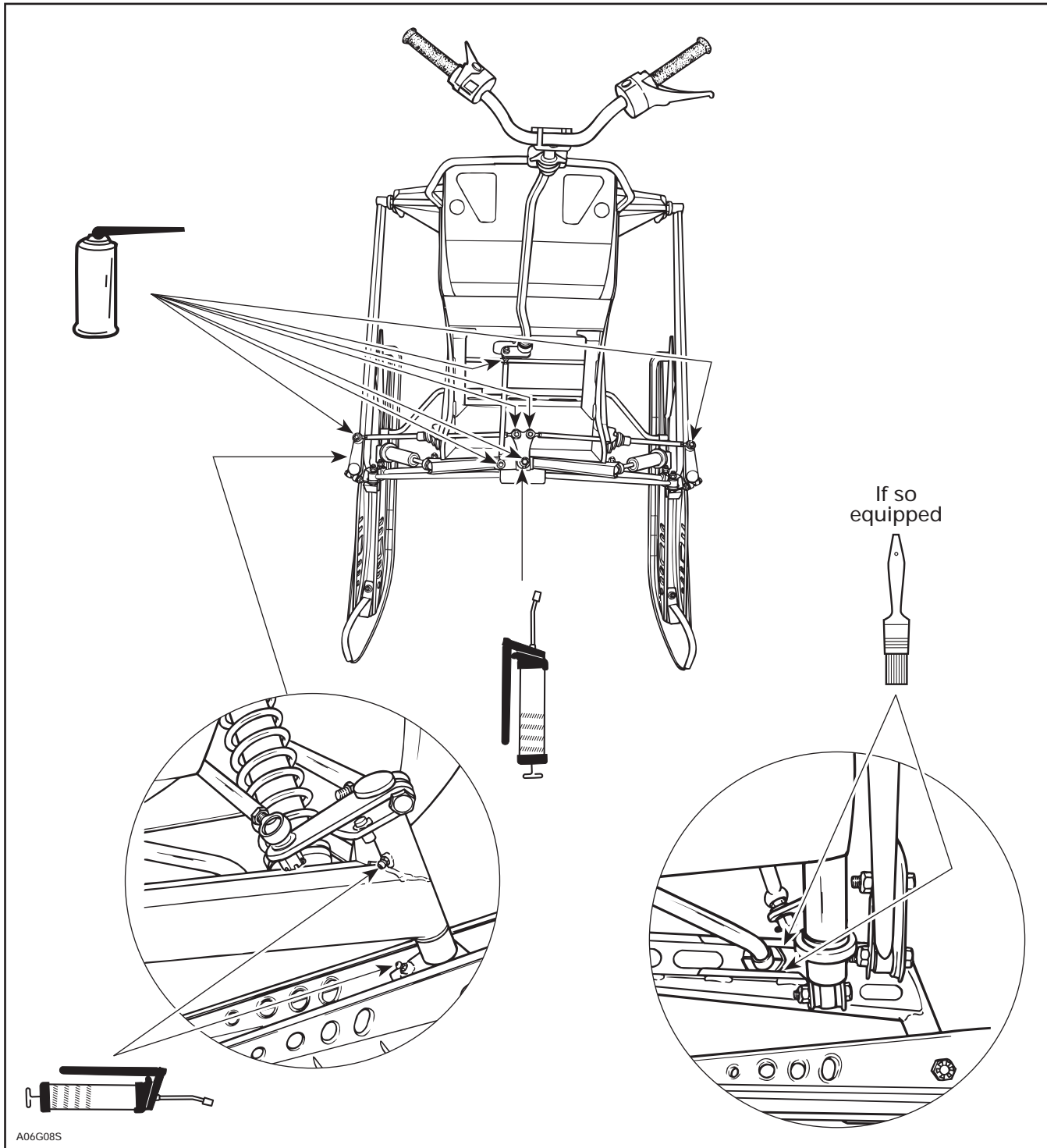

SUSPENSION AND SKI SYSTEM

F-Series

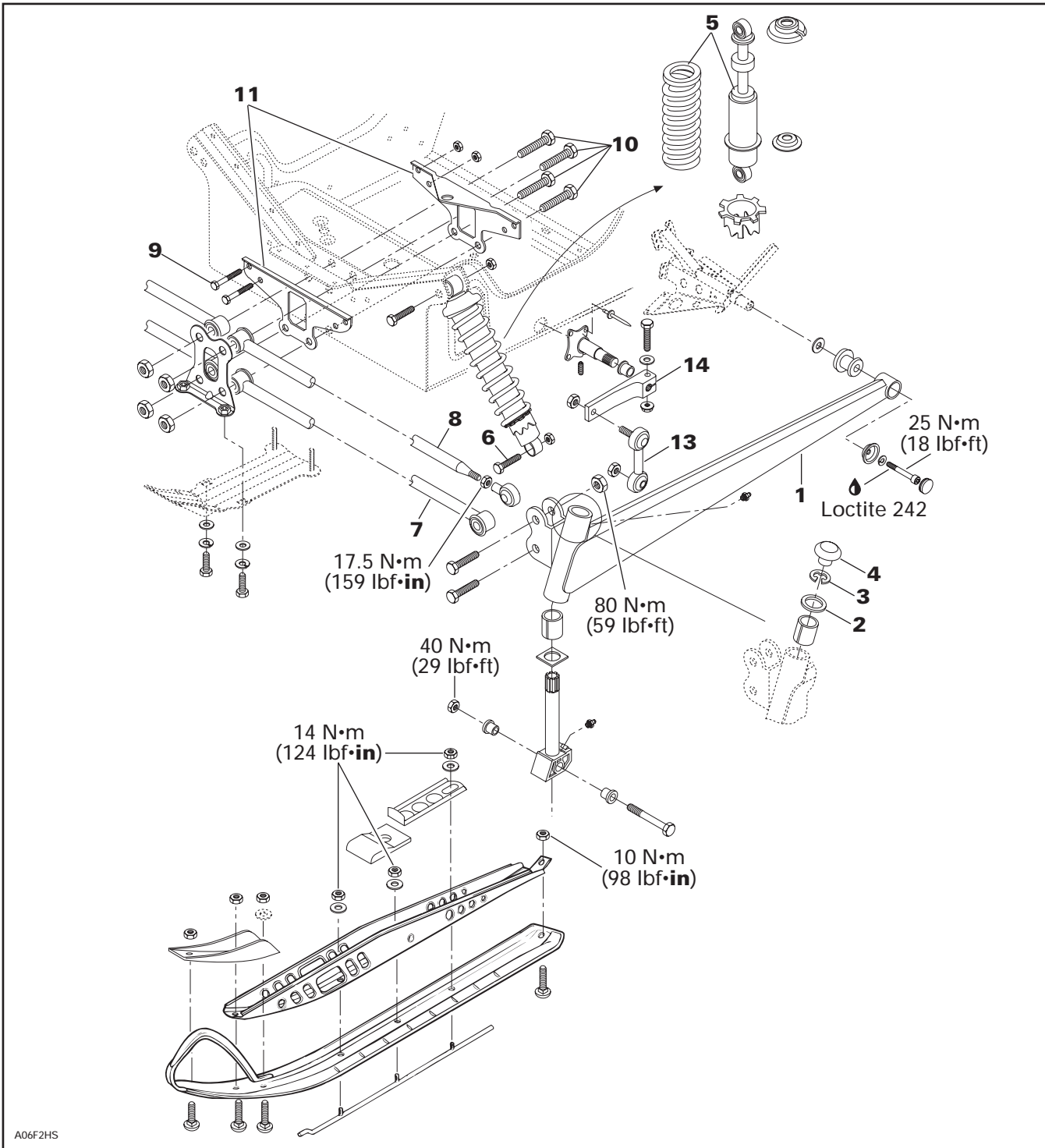

Section 07 STEERING/FRONT SUSPENSION

Sub-Section 03 (SUSPENSION AND SKI SYSTEM)

DISASSEMBLY

5, Shock

Lift front of vehicle and support it off the ground.

Reduce spring preload by turning adjusting ring accordingly with the adjustment wrench in vehicle tool box.

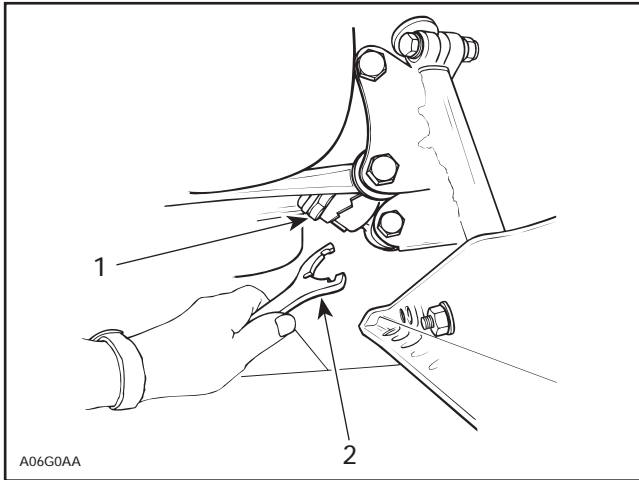

TYPICAL

1. Shock cam
2. Adjustment wrench

Remove lower bolt then upper bolt of shock.

For shock spring disassembly use shock spring remover (P/N 529 0271 00) in a vise. Mount shock in it and turn shock so that spring coils matched spring compressor.

Close and lock the bar. Adjust the handle horizontal position by changing the position of the clevis pin.

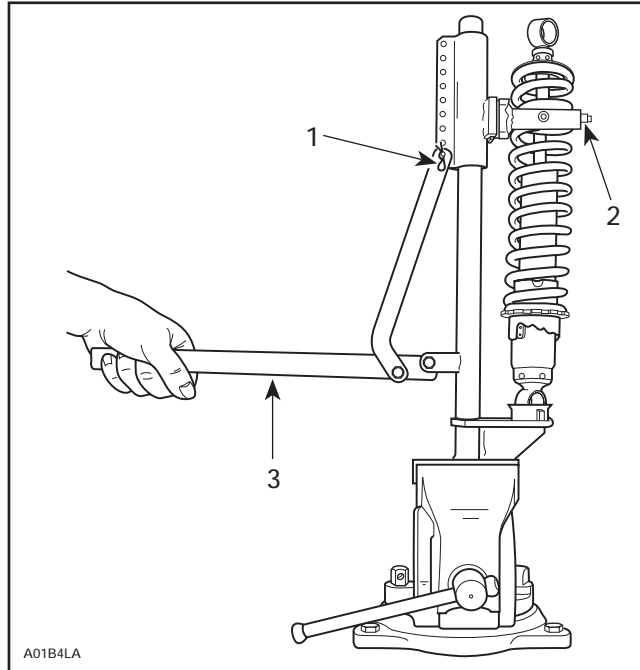

A01B4LA

1. Clevis pin
2. Bar
3. Handle horizontal

Push down on the handle until it locks. Remove spring stopper and cap then release handle.

When installing the cap opening must be 180° from the spring stopper opening.

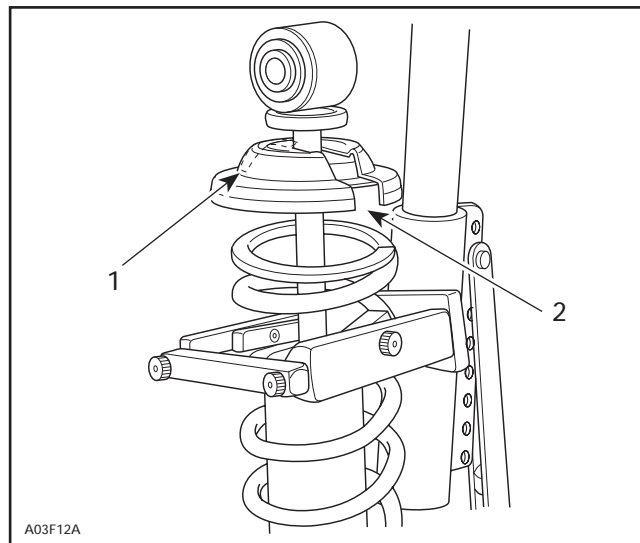

A03F12A

1. Cap opening
2. Spring stopper opening

Section 07 STEERING/FRONT SUSPENSION

Sub-Section 03 (SUSPENSION AND SKI SYSTEM)

1, Swing Arm

Lift front of vehicle and support it off the ground.

Remove cap, circlip then loosen steering arm bolt and pull up steering arm. Note shim positions. Ski leg may fall off from swing arm.

Unbolt lower end of shock from swing arm.

Unbolt radius rod.

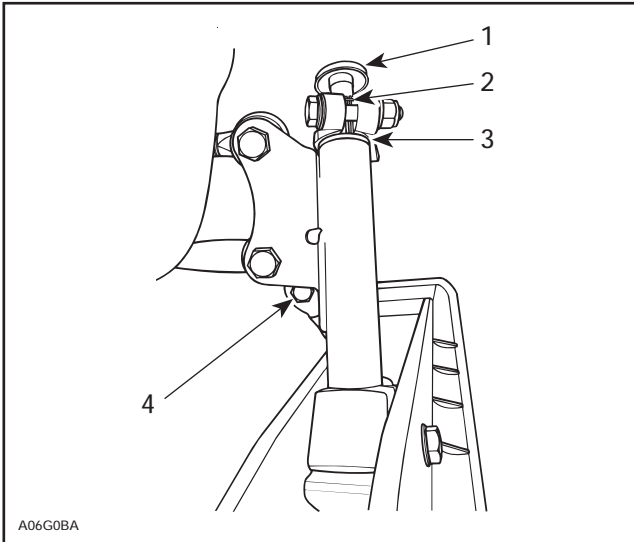

1. Cap no. 4
2. Circlip no. 3
3. Shims no. 2
4. Bolt retaining lower end of shock no. 6

14, Lever

Unbolt tie rod no. 13 ball joint from swing arm, do not change stabilizer adjustments at this time.

Unbolt rear of swing arm from frame.

Pull swing arm off the vehicle. Stabilizer bar will disengage ball joint at swing arm inside rails.

INSPECTION

Check all rubber cushions for crack and wear. Replace as required.

Check straightness of splines and proper interlocking with steering arm. Replace as required.

Check for straightness of swing arm. Replace as required.

Check for clogged grease fittings. Clean or replace as required.

Check for proper action of sliding blocks in swing arm.

Check skis and runners for wear, replace as necessary.

Check condition of ski stopper. Replace it when deteriorated.

To check condition of shock, refer to SC-10 SUSPENSION 06-02 then look for **Shock Absorber Inspection**.

INSTALLATION

For assembly, reverse the disassembly procedure. However, pay attention to the following.

Apply low temperature grease (P/N 413 7061 00) to ski leg components.

Tighten nuts and screws to proper torque as mentioned in exploded view.

7,8, Upper and Lower Half Arms

Position half arms and tie rods horizontally before tightening nuts.

8, Adjustable Half Arm

Refer to STEERING SYSTEM 07-02 for proper camber adjustment using these half arms.

9,10,11, Bolt, Nut and Link Plate

Attach link plate to frame with additional nuts and bolts.

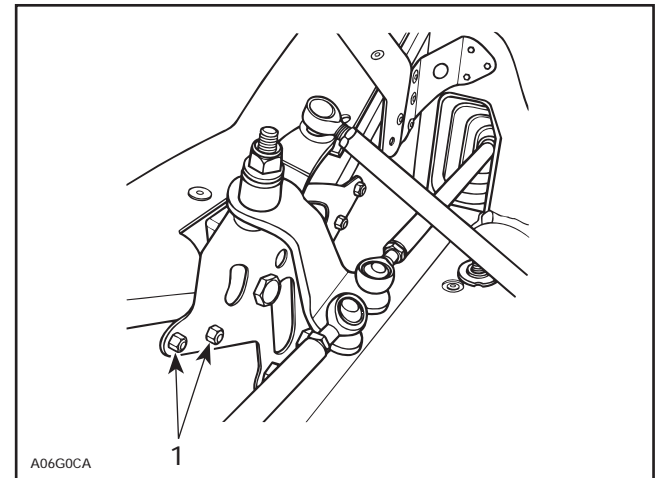

1. Nuts and bolts

Section 07 STEERING/FRONT SUSPENSION
Sub-Section 03 (SUSPENSION AND SKI SYSTEM)

13,14, Tie Rod and Lever

Install levers on both sides at same angle (about horizontal).

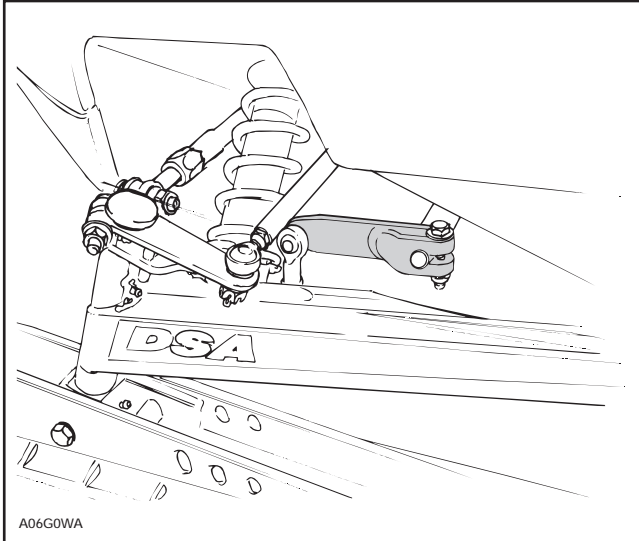

TYPICAL

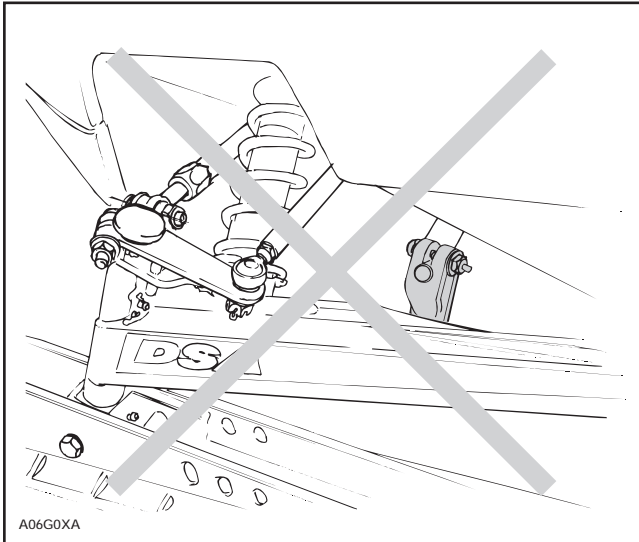

WRONG POSITION

TABLE OF CONTENTS

BODY	08-02-1
INSTALLATION AND ADJUSTMENT	08-02-1
HEADLAMP BEAM AIMING	08-02-1
BULB REPLACEMENT	08-02-1
DECAL	08-02-2
WINDSHIELD INSTALLATION.....	08-02-2
HOOD	08-02-2
BELT GUARD	08-02-2
WIRING HARNESS	08-02-2
CABLES	08-02-3
PIPING	08-02-3
PLASTIC MAINTENANCE AND REPAIR	08-02-4
MAINTENANCE	08-02-4
REPAIR.....	08-02-5
MATERIAL REPAIR PROCEDURE.....	08-02-6
REPAIR PROCEDURE FOR R.I.M. URETHANE.....	08-02-6

FRAME	08-03-1
FRAME CLEANING	08-03-1
FRAME WELDING	08-03-1
FRAME COMPONENT REPLACEMENT	08-03-1

BODY

INSTALLATION AND ADJUSTMENT

HEADLAMP BEAM AIMING

Beam aiming is correct when center of high beam is 25 mm (1 in) below the headlamp horizontal center line, scribed on a test surface, 381 cm (12 ft 6 in) away.

Measure headlamp center distance from ground. Scribe a line at this height on test surface (wall or screen). Light beam center should be 25 mm (1 in) below scribed line.

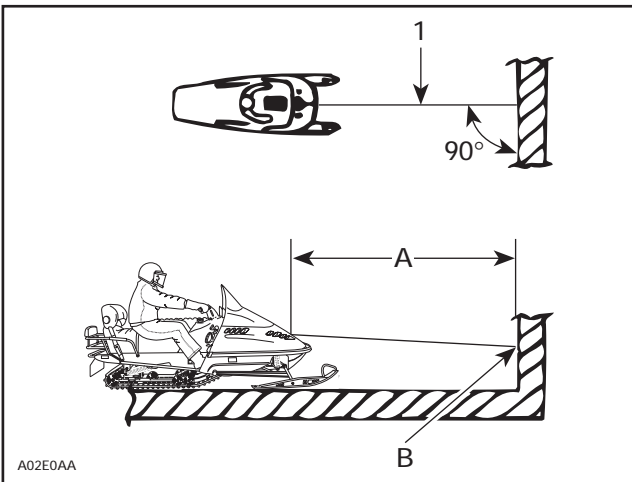

- 1. Headlamp center line
- A. 381 cm (12 ft 6 in)
- B. 25 mm (1 in) below center line

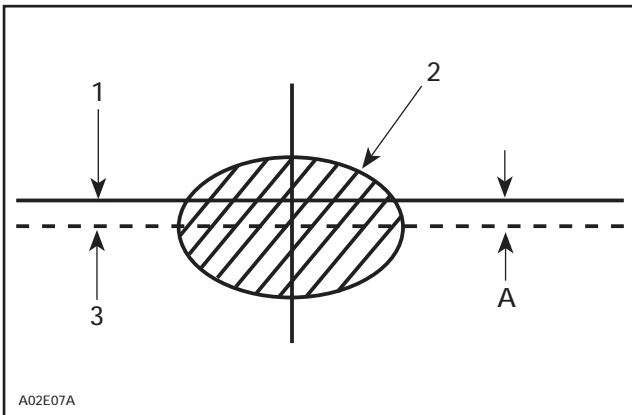

- 1. Headlamp horizontal
- 2. Light beam (high beam) (projected on the wall)
- 3. Light beam center
- A. 25 mm (1 in)

Required Conditions

Place the vehicle on a flat surface perpendicular to test surface (wall or screen) and 381 cm (12 ft 6 in) away from it.

Rider or equivalent weight must be on the vehicle.

Select **high beam**.

BULB REPLACEMENT

If headlamp bulb is burnt, tilt cab and unplug the connector from the headlamp. Remove the rubber boot and unfasten the bulb retainer clips or locking ring.

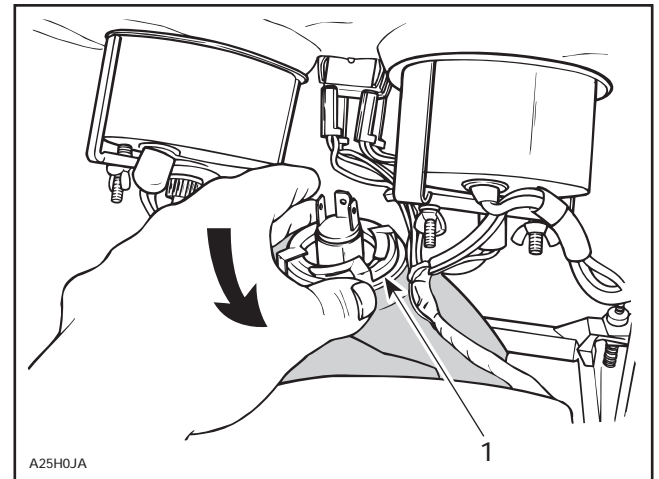

TYPICAL

- 1. Locking ring

Replace bulb. If the taillight bulb is burnt, expose the bulb by removing red plastic lens. To remove, unscrew the 2 retaining screws. Verify all lights after replacement.

▼ CAUTION

Never touch glass portion of an halogen bulb with bare fingers, as it shortens its operating life. If by mistake glass is touched, clean it with isopropyl alcohol which will not leave a film on the bulb.

Section 08 BODY/FRAME

Sub-Section 02 (BODY)

DECAL

To remove a decal; heat old decal with a heat gun and peel off slowly.

Using isopropyl alcohol, clean the surface and dry thoroughly.

Apply liquid soap to new decal and carefully position the decal. Using a sponge or a squeegee, remove the air bubbles and surplus water working from the center toward the edges. Allow to air dry.



CAUTION

Do not apply isopropyl alcohol or solvent directly on decals.

WINDSHIELD INSTALLATION

When peeling off the protective film some polyethylene particles may remain on the windshield. A soft clean cloth moistened with naphtha (camping equipment fuel) will easily remove the remaining particles.



WARNING

Naphtha is flammable and explosive under certain conditions. Always manipulate in a well ventilated area. Do not smoke or allow open flames or sparks in the vicinity.

Position the windshield on the hood then push it down until the tabs are fully inserted into the hood slots. Lock the windshield tabs in position.

HOOD

F Series

Unfasten speedometer cable, wiring harnesses then retaining cables.

Unbolt front molding and unclip it.

Close hood.

Remove molding.

Remove hinge pin.

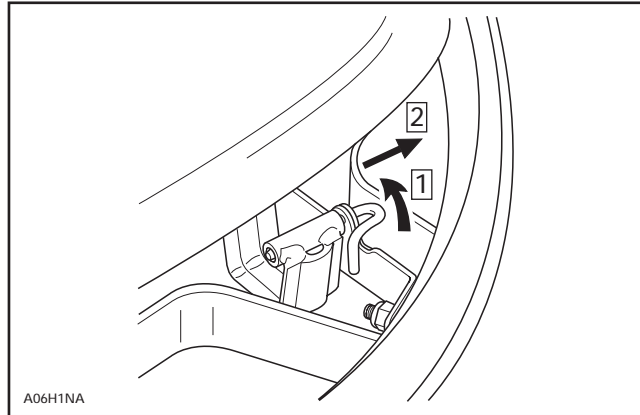

At installation, half close hood to install front molding.

BELT GUARD

Disassembly and Assembly

NOTE: For additional information (ex.: exploded view) refer to the correspondent parts catalog.



WARNING

Engine should be running only with belt guard and/or pulley guard well secured in place.

Inspection

Check belt guard and/or pulley guard mounting bosses, clips and retainers for wear.

WIRING HARNESS



WARNING

Ensure all terminals are properly crimped on the wires and that all connector housings are properly fastened. Keep wires away from any rotating, moving, heating and vibrating parts. Use proper fastening devices as required.

CABLES

◆ WARNING

Before installation, ensure that all cables are in perfect condition. Properly install the cable ends and secure them in place. Pay attention to route them properly, away from any rotating, moving, heating, or vibrating parts.

PIPING

◆ WARNING

Always ensure that the fuel, vent, primer, impulse, injection oil and rotary valve oil lines are properly fixed to their connectors, that they are not perforated or kinked and that they are properly routed away from any rotating, moving, heating or vibrating parts. Also check for leaks. Replace if required.

NOTE: Refer to proper *Parts Catalog* to find suitable clip part numbers.

Section 08 BODY/FRAME

Sub-Section 02 (BODY)

PLASTIC MAINTENANCE AND REPAIR

MAINTENANCE

Clean the vehicle thoroughly, removing all dirt and grease accumulation.

To clean use a soft clean cloth and either soapy water or isopropyl alcohol.

To remove grease, oil or glue use isopropyl alcohol.

▼ CAUTION

Do not apply isopropyl alcohol or acetone directly on decals.

▼ CAUTION

The following products must not be used to clean or wax any of the plastic components used on the vehicles:

- gasoline
- brake fluid
- kerosene
- diesel fuel
- lighter fluid
- varsol
- naphtha
- acetone
- strong detergents
- abrasive cleaners
- waxes containing an abrasive or a cleaning agent in their formula

▼ CAUTION

Clean R.I.M. Metton® with isopropyl alcohol only. Never use cleaners or products containing chlorine.

Apply wax on glossy finish only. Protect the vehicle with a cover to prevent dust accumulation during storage.

▼ CAUTION

If for some reason the snowmobile has to be stored outside it is preferable to cover it with an opaque tarpaulin. This will prevent the sun rays from affecting the plastic components and the vehicle finish.

REPAIR

The very first step before repairing plastic materials is to find out exactly which type of material is involved. Refer to following chart.

▼	CAUTION
Consult chart and repair kit instructions carefully, some repair products are not compatible with certain plastics.	

◆	WARNING
Polycarbonate windshields must never be repaired by welding or otherwise.	

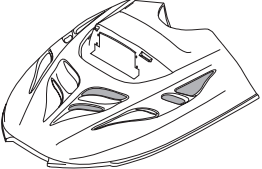
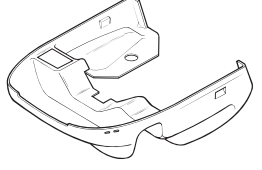
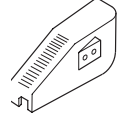
PART	MODEL	REPAIRABLE		
		FIBERGLASS	R.I.M. URETHANE	POLYETHYLENE
<p>HOOD</p>  <p style="font-size: 0.8em;">A06H194</p>	F-Series			
<p>BOTTOM PAN</p>  <p style="font-size: 0.8em;">A06H1A4</p>	F-Series			
<p>SIDE PANEL AND REAR MOLDING</p>  <p style="font-size: 0.8em;">A06H1B4</p>	F-Series			

Section 08 BODY/FRAME

Sub-Section 02 (BODY)

MATERIAL REPAIR PROCEDURE

R.I.M. Urethane

R.I.M. Urethane is light colored (tan) on the inside with a smooth surface.



WARNING

Material should be repaired and repainted in a well ventilated area only.



CAUTION

Clean R.I.M. with isopropyl alcohol or Crest Hi-Solv product. **Never** use cleaners or products that contain **chlorine**.



CAUTION

R.I.M. should never be exposed to temperatures exceeding 93°C (200°F).

NOTE: When working on a R.I.M. surface, never use a grinder or a high revolution tool such as an air or electric buffer. Use of such tools could over-heat material and liberate agents in it thus causing a bad adhesion.

REPAIR PROCEDURE FOR R.I.M. URETHANE

Small Scratches

- Sand and scuff area.
- Feather out edges.
- Paint with a matching acrylic auto touch-up paint.

Deep Scratches

- Sand and scuff area.
- Make a V groove using a knife or a rough round file.
- Clean surface with isopropyl alcohol or Crest Hi-Solv stock no. AH-S product.
- Cover with TP-E epoxy mixed in equal quantities.
- Heat the surface with a heater lamp placed at 38 cm (15 in) for a period of 15 minutes.
- Sand the repair using a smooth dry sand paper.

- Use the same product if a final finish is required.
- Clean surface with Crest Hi-Solv product.
- Apply a flexible primer such as Crest Prima Flex stock no. AP-F.
- Wait 10 minutes.
- Repaint (air dry during 72 hours (approximately)).

Large Crack

- Sand and scuff outside and inside area by exceeding it 31.7 mm (1-1/4 in) on each side and 12.7 mm (1/2 in) at each end.
- Make a V groove (appr. 90°) on both sides of hood using a knife or a rough round file.
- Enlarge the crack to 2.4 mm (3/32 in) – 3.2 mm (1/8 in) using a sharp knife.
- Clean outside and inside surface with isopropyl alcohol or Crest Hi-Solv product.
- Repair inside surface first.
- Cover inside area with Crest TP-E epoxy.
- Apply a 50 mm × 30 mm (2 in × 1-1/4 in) patch. If no room for the patch, use tape.
- Cover exterior surface with same product. Damaged area should be slightly higher.
- Heat surface with a heater lamp placed at 38 mm (15 in) for a period of 15 minutes.
- Sand outside repair using a smooth dry sand paper.
- Use same product if a final finish is required.
- Apply a flexible primer.
- Wait 10 minutes.
- Repaint (air dry during 72 hours approximately).

NOTE: Both R.I.M. materials are high static plastics, painting must be done in a dust free area such as a paint booth.

Section 08 BODY/FRAME**Sub-Section 02 (BODY)****CREST MAIN OFFICE AND MANUFACTURING PLANT**

CREST INDUSTRIES, INC.
3841 13th Street
Wyandotte, Michigan
48192

Phone: 313-283-4100
Toll Free: 1-800-822-4100
Fax: 1-800-344-4461
Fax: 313-283-4461

Crest products used in R.I.M. repair procedure are available from following locations:

DISTRIBUTOR WAREHOUSE LOCATIONS

UNITED STATES		CANADA
<p>CREST EAST COAST, INC. P.O. Box 550 1109 Industrial Parkway Brick, New Jersey 08723 Phone: 908-458-9000 Fax: 908-458-5753</p> <p>CREST PRODUCTS, INC. <i>Shipping Address:</i> 125 Production Drive Yorktown, Virginia 23693 Phone: 804-599-6572 Virginia: 1-800-572-5025 Outstate: 1-800-368-5033 Fax: 804-599-6630</p> <p><i>Mailing Address:</i> P.O. Box 2018 Grafton, Virginia 23692</p> <p>CREST INDUSTRIES SOUTHEAST, INC. <i>Shipping Address:</i> 4300 Glen Haven Drive Decatur, Georgia 30035 Phone: 404-288-4658 Toll Free: 1-800-552-0876 Fax: 404-288-4658</p> <p><i>Mailing Address:</i> P.O. Box 254 Decatur, Georgia 30031</p>	<p>CREST INDUSTRIES, INC. (CREST MID-WEST) 231 Larkin Williams Ind. Court St. Louis, Missouri 63026 Phone: 314-349-4800 Toll Free: 1-800-733-2737 Fax: 314-349-4888 Toll Free Fax: 1-800-776-2737</p> <p>CREST MID WEST Regional Branch Warehouses</p> <p>CREST INDUSTRIES, INC. P.O. Box 635 Mountain Home, Arkansas 72653 Phone: 501-491-5583 Toll Free: 1-800-733-2737</p> <p>4200 Jackson Street, Unit 9 Denver, Colorado 80216 Phone: 303-320-3900 Toll Free: 1-800-733-2737 Fax: 303-320-6509</p> <p>REM-CO DISTRIBUTING, INC. 5625 S. Adams Tacoma, Washington 98409 Phone: 206-474-5414 Toll Free: 1-800-735-7224 Fax: 206-474-7339</p>	<p>J2 PRODUCTS A Division of Sawill Ltd. 54 Audia Court, Unit 2A Concord, Ontario, L4K 3N4</p> <p><i>Phone:</i> <i>Toronto:</i> 416-665-1404 <i>Concord:</i> 905-669-9410 <i>Montréal:</i> 514-655-6505</p> <p><i>Fax:</i> Concord: 905-669-9419 Montréal: 514-655-6505</p> <p>WHEEL-IN AUTOMOTIVE SUPPLY <i>Shipping Address:</i> # 1, 3911A Brandon St. S.E. Calgary, Alberta, T2G 4A7</p> <p>Office: 403-287-0775</p> <p><i>Mailing Address:</i> P.O. Box 40036 929-42nd Avenue S.E. Calgary, Alberta, T2G 5G5</p>

FRAME

FRAME CLEANING

NOTE: For aluminum frames use only aluminum cleaner and follow instructions on container. (Dursol cleaner or equivalent).

Clean frame and tunnel with appropriate cleaners and rinse with high pressure hose.

Touch up all metal spots where paint has been scratched off. Spray all bare metal parts of vehicle with metal protector.

Seat Cleaning

For all models, it is recommend to clean the seat with a solution of warm soapy water, using a soft clean cloth.

▼ CAUTION

Avoid use of harsh detergents such as strong soaps, degreasing solvents, abrasive cleaners, paint thinners, etc. that may cause damage to the seat cover.

FRAME WELDING

Steel Frame:

- electric welding
- amperage: 70-110 A
- voltage: 20-24 V
- rod: E-7014 (3/32 in)

Aluminum Frame: (refer to specialized welding shop)

- argon-oxygen/acetylene welding
- rod: ER-4043 (3/32 in)

▼ CAUTION

Before performing electrical welding anywhere on the vehicle, unplug the multiple connector at the electronic box. On models equipped with a battery, also unplug the negative cable. This will protect the electronic box and battery against damage caused by flowing current when welding.

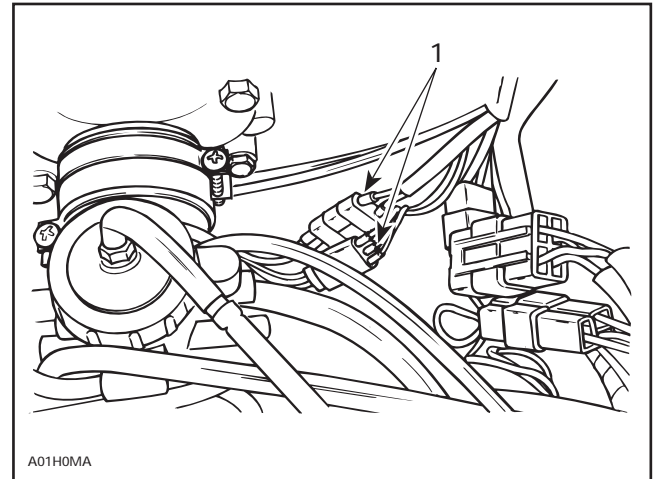

TYPICAL

1. Unplug before electrical welding

▼ CAUTION

If welding is to be done near plastic material, it is recommended to either remove the part from the area or to protect it with aluminum foil to prevent damage.

FRAME COMPONENT REPLACEMENT

Drilling Procedure

When drilling self-piercing rivets, use Supertanium™ drill bit (P/N 529 0318 00), available in a 5 mm (3/16 in) size and shipped in packs of 2.

For proper drilling instructions and to prevent premature wear, follow the procedure below.

Always use a variable speed electric drill.

It is not necessary to center punch the rivet head, simply center the drill bit on the rivet and drill.

Maintain a slow to medium speed at all times when drilling. The proper speed is attained when a constant chip is ejected.

NOTE: To increase bit life, use Bombardier synthetic chaincase oil (P/N 413 8033 00) as a cutting oil.

Section 08 BODY/FRAME

Sub-Section 03 (FRAME)

▼ CAUTION

High speed drilling will cause excessive heat which may destroy the cutting edge of the bit, therefore avoid using pneumatic drills.

Grinding Procedure

Rear Cap

Grind rivet heads from top of rear cap and underneath for side retaining rivets.

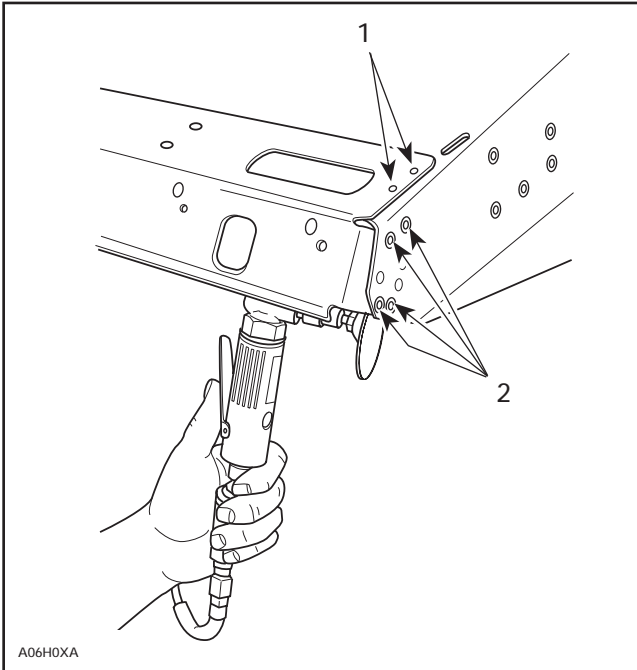

1. Rivets heads ground
2. Rivets to be ground from underneath

To remove rivet, strike with a punch from rivet head side.

Make a chamfer from underneath on all 4 corner holes.

TECHNICAL DATA

SI* METRIC INFORMATION GUIDE

BASE UNITS			
DESCRIPTION	UNIT	SYMBOL	
length	meter	m	
mass	kilogram	kg	
force	newton	N	
liquid	liter	L	
temperature	Celsius	°C	
pressure	kilopascal	kPa	
torque	newton•meter	N•m	
speed	kilometer per hour	km/h	

PREFIXES			
PREFIX	SYMBOL	MEANING	VALUE
kilo	k	one thousand	1 000
centi	c	one hundredth	0.01
milli	m	one thousandth	0.001
micro	μ	one millionth	0.000001

CONVERSION FACTORS			
TO CONVERT	TO †	MULTIPLY BY	
in	mm	25.4	
in	cm	2.54	
in ²	cm ²	6.45	
in ³	cm ³	16.39	
ft	m	0.3	
oz	g	28.35	
lb	kg	0.45	
lbf	N	4.4	
lbf•in	N•m	0.11	
lbf•ft	N•m	1.36	
lbf•ft	lbf•in	12	
PSI (lbf/in ²)	kPa	6.89	
imp. oz	U.S. oz	0.96	
imp. oz	mL	28.41	
imp. gal	U.S. gal	1.2	
imp. gal	L	4.55	
U.S. oz	mL	29.57	
U.S. gal	L	3.79	
MPH	km/h	1.61	
Fahrenheit	Celsius	(°F – 32) ÷ 1.8	
Celsius	Fahrenheit	(°C × 1.8) + 32	







* The international system of units abbreviates SI in all languages.

† To obtain the inverse sequence, divide by the given factor. To convert "mm" to "in", divide by 25.4.





NOTE: Conversion factors are rounded off to 2 decimals for easier use.

Section 09 TECHNICAL DATA

Sub-Section 02 (ENGINES)





		VEHICLE MODEL	FORMULA III/III LT	MACH 1	MACH Z/Z LT		
		ENGINE TYPE	599	699	809		
	Number of Cylinders		3	3	3		
	Bore		67.5 (2.5394) mm (in)	69.5 (2.7461) mm (in)	70.5 (2.7756) mm (in)		
	Stroke		61.0 (2.402) mm (in)	61.0 (2.402) mm (in)	68.0 (2.677) mm (in)		
	Displacement		597.94 (36.49) cm ³ (in ³)	699.2 (42.7) cm ³ (in ³)	796.3 (48.59) cm ³ (in ³)		
	Compression Ratio (corrected)		6.8	6.8	6.8		
	Maximum Power Engine Speed ①		± 100 RPM	8500	8500	8300	
	Piston Ring Type		1 st /2 nd	ST/R	ST/R	ST/R	
	Ring End Gap		new	0.2 (.008) mm (in)	0.2 (.008) mm (in)	0.20 (.008) mm (in)	
			wear limit	1.0 (.039) mm (in)	1.0 (.039) mm (in)	1.0 (.039) mm (in)	
	Ring/Piston Groove Clearance		new	0.03 (.0012) mm (in)	0.03 (.0012) mm (in)	0.03 (.0012) mm (in)	
			wear limit	0.2 (.008) mm (in)	0.2 (.008) mm (in)	0.2 (.008) mm (in)	
	Piston/Cylinder Wall Clearance		new	0.07 (.0028) mm (in)	0.10 (.0039) mm (in)	0.11 (.0043) mm (in)	
			wear limit	0.15 (.0059) mm (in)	0.15 (.0059) mm (in)	0.15 (.0059) mm (in)	
	Connecting Rod Big End Axial Play		new	0.39 (.0154) mm (in)	0.39 (.0154) mm (in)	0.31 (.0122) mm (in)	
			wear limit	1.2 (.0472) mm (in)	1.2 (.0472) mm (in)	1.2 (.0472) mm (in)	
Maximum Crankshaft End-play ②		mm (in)	0.3 (.0118) mm (in)	0.3 (.0118) mm (in)	0.3 (.012) mm (in)		
Maximum Crankshaft Deflection		mm (in)	0.08 (.0031) mm (in)	0.08 (.0031) mm (in)	0.08 (.0031) mm (in)		
Rotary Valve Timing ③ and P/N 420 924 XXX		Opening Closing	N.A.	N.A.	N.A.		
	Magneto Generator Output		W	220	220	220	
	Ignition Type		CDI	CDI	CDI		
	Spark Plug Make and Type		NGK BR10ES	NGK BR10ES	NGK BR10ES		
	Spark Plug Gap		mm (in)	0.45 (.018) mm (in)	0.45 (.018) mm (in)	0.45 (.018) mm (in)	
	Ignition Timing BTDC ④		mm (in)	2.18 (.086) mm (in)	2.18 (.086) mm (in)	2.11 (.083) mm (in)	
	Trigger Coil ⑤		Ω	190 – 300	190 – 300	190 – 300	
	Generating Coil ⑤		Low Speed	Ω	49 – 75	49 – 75	49 – 75
			High Speed	Ω	2.8 – 4.3	2.8 – 4.3	2.8 – 4.3
	Lighting Coil ⑤		Ω	0.20 – 0.35	0.20 – 0.35	0.20 – 0.35	
	High Tension Coil ⑤		Primary	Ω	0.2 – 0.5	0.2 – 0.5	0.2 – 0.5
Secondary			kΩ	6 – 13	6 – 13	6 – 13	
	Carburetor Type		PTO/CTR/MAG	VM 36-176/177/178	VM 38-356/357/358	3 x TM 38-C159	
	Main Jet		PTO/CTR/MAG	330/330/330	350/350/350	380/380/380	
	Needle Jet			256 P-0	480 P-7	327 O-4	
	Pilot Jet			50	50	50	
	Needle Identification – Clip Position			6DEY4-3	6DEY2-4	8AGY1-41	
	Slide Cut-away			2.5	2.5	2.0	
	Float Adjustment		± 1 mm (± .040 in)	18.1 (.71) mm (in)	18.1 (.71) mm (in)	20.0 (.79) mm (in)	
	Air Screw Adjustment		± 1/16 Turn	1-1/2	2-1/4	4	
	Idle Speed RPM		± 200 RPM	1900	1800	1800	
	Gas Type/Pump Octane Number			Super Unleaded/91	Super Unleaded/91	Super Unleaded/91	
	Gas/Oil Ratio			Injection	Injection	Injection	
	Type		Liquid	Liquid	Liquid		
	Axial Fan Belt Adjustment		Deflection ⑥	mm (in)	N.A.	N.A.	
			Force	kg (lbf)	N.A.	N.A.	
	Thermostat Opening Temperature		°C (°F)	42 (108) °C (°F)	42 (108) °C (°F)	42 (108) °C (°F)	
Radiator Cap Opening Pressure		kPa (PSI)	90 (13) kPa (PSI)	90 (13) kPa (PSI)	90 (13) kPa (PSI)		
	Drive Pulley Retaining Screw		⑦	⑦	⑦		
	Exhaust Manifold Nuts or Bolts			9 (6.6) kg (lbf)	9 (6.6) kg (lbf)	9 (6.6) kg (lbf)	
	Magneto Ring Nut			125 (92) kg (lbf)	125 (92) kg (lbf)	125 (92) kg (lbf)	
	Crankcase Nuts or Screws		M6	13 (9.5) kg (lbf)	13 (9.5) kg (lbf)	13 (9.5) kg (lbf)	
			M8	22 (16) kg (lbf)	22 (16) kg (lbf)	29 (21) kg (lbf)	
	Crankcase/Engine Support Nuts or Screws			13 (9.6) kg (lbf)	13 (9.6) kg (lbf)	13 (9.6) kg (lbf)	
	Cylinder Head Nuts			29 (21) kg (lbf)	29 (21) kg (lbf)	29 (21) kg (lbf)	
	Crankcase/Cylinder Nuts or Screws			29 (21) kg (lbf)	29 (21) kg (lbf)	29 (21) kg (lbf)	
Axial Fan Shaft Nut			N.A.	N.A.	N.A.		

Section 09 TECHNICAL DATA
Sub-Section 03 (VEHICLES)

		VEHICLE MODEL	FORMULA III	FORMULA III LT	MACH 1	MACH Z	
		ENGINE TYPE	599	599	699	809	
	Chain Drive Ratio		25/44	23/44	26/44	26/44	
	Chain	Pitch in	3/8	3/8	3/8	3/8	
		Type/Links Qty/Plates Qty		Silent/74/13	Silent/72/13	Silent/74/13	Silent/74/13
	Drive Pulley	Type of Drive Pulley		TRA	TRA	TRAC	TRAC
		Ramp Identification		281 ⊕	281 ⊕	286 ⊕	286 ⊕
		Calibration Screw Position or Calibration Disc Quantity		4	4	4	3
		Spring Color		Pink/White	Pink/White	Pink/White	Green/Blue
		Spring Length ± 1.5 mm (± 0.060 in)		124.5 (4.90)	124.5 (4.90)	124.5 (4.90)	147.4 (5.80)
		Clutch Engagement ± 200 RPM		4500	4500	4500	4100
	Driven Pulley Spring Preload ± 0.7 kg (±1.5 lb)		7.0 (15.4)	7.0 (15.4)	7.0 (15.4)	7.0 (15.4)	
	Cam Angle degree		50°	50°	47° – 50°	47° – 50°	
	Pulley Distance Z (+ 0, -1) mm (+ 0, -1/32) in		16.5 (21/32)	16.5 (21/32)	16.5 (21/32)	16.5 (21/32)	
	Offset	X ± 0.4 mm (± 1/64 in)		35.0 (1-3/8)	35.0 (1-3/8)	35.0 (1-3/8)	35.0 (1-3/8)
		Y – X	MIN. – MAX. mm (in)	1.0 – 2.0 (0.039 – 0.079)	1.0 – 2.0 (0.039 – 0.079)	1.0 – 2.0 (0.039 – 0.079)	1.0 – 2.0 (0.039 – 0.079)
	Drive Belt Part Number (P/N)			415 0603 00	415 0603 00	415 0603 00	415 0603 00
	Drive Belt Width (new) ① mm (in)			35.0 (1-3/8)	35.0 (1-3/8)	35.0 (1-3/8)	35.0 (1-3/8)
	Drive Belt Adjustment	Deflection ± 5 mm (± 13/64 in)		32 (1-1/4)	32 (1-1/4)	32 (1-1/4)	32 (1-1/4)
		Force ② kg (lbf)		11.3 (25)	11.3 (25)	11.3 (25)	11.3 (25)
	Track	Width cm (in)		38.1 (15)	38.1 (15)	38.1 (15.0)	38.1 (15.0)
		Length cm (in)		307 (121)	345.5 (136)	307 (121)	307 (121)
Adjustment		Deflection mm (in)	35 – 40 (1-3/8 – 1-9/16)	35 – 40 (1-3/8 – 1-9/16)	35 – 40 (1-3/8 – 1-3/4)	35 – 40 (1-3/8 – 1-3/4)	
		Force ③ kg (lbf)	7.3 (16)	7.3 (16)	7.3 (16)	7.3 (16)	
Suspension Type	Track		SC10 HP	SC10 HP	SC10 HP	SC10 HP	
	Ski		DSA	DSA	DSA	DSA	
	Length cm (in)		272.0 (107.1)	291.0 (114.6)	272.0 (107.1)	272.5 (107.3)	
	Width cm (in)		115.9 (45.6)	118.2 (46.5)	115.9 (45.6)	115.9 (45.6)	
	Height cm (in)		108 (42.5)	108 (42.5)	108 (42.5)	108 (42.5)	
	Ski Stance cm (in)		104.2 (41)	104.2 (41)	104.2 (41)	104.2 (41)	
	Mass (dry) kg (lb)		249 (548)	252 (554)	251 (552)	258 (568)	
	Ground Contact Area cm² (in²)		6103 (946)	7549 (1170)	6103 (946)	6103 (946)	
	Ground Contact Pressure kPa (PSI)		4.00 (.580)	3.27 (.474)	4.03 (.584)	4.15 (.602)	
	Frame Material		Aluminum	Aluminum	Aluminum	Aluminum	
	Bottom Pan Material		Impact Copolymer	Impact Copolymer	Impact Copolymer	Impact Copolymer	
	Hood Material		RRIM Polyurethane	RRIM Polyurethane	RRIM Polyurethane	RRIM Polyurethane	
	Battery V (A•h)		N.A.	N.A.	N.A.	N.A.	
	Headlight W		H4 60/55	H4 60/55	H4 60/55	H4 60/55	
	Taillight and Stoplight W		8/27	8/27	8/27	8/27	
	Tachometer and Speedometer Bulb W		2 x 3	2 x 3	2 x 3	2 x 3	
	Fuel and Temperature Gauge Bulb W		3/3	3/3	3/3	3/3	
	Fuse	Starter Solenoid A		N.A.	N.A.	N.A.	N.A.
		Tachometer A		N.A.	N.A.	N.A.	N.A.
	Fuel Tank L (U.S. gal)		42 (11.1)	42 (11.1)	42 (11.1)	42 (11.1)	
	Chaincase/Gearbox mL (U.S. oz)		250 (8.5)	250 (8.5)	250 (8.5)	250 (8.5)	
	Cooling System ④ L (U.S. oz)		5.0 (169)	5.1 (172)	5.0 (169)	5.0 (169)	
	Injection Oil Reservoir L (U.S. oz)		4.1 (139)	4.1 (139)	4.1 (139)	4.1 (139)	

Section 09 TECHNICAL DATA

Sub-Section 03 (VEHICLES)

		VEHICLE MODEL	MACH Z LT	
		ENGINE TYPE	809	
		Chain Drive Ratio	25/44	
Chain	Pitch	in	3/8	
	Type/Links Qty/Plates Qty		Silent/74/13	
Drive Pulley	Type of Drive Pulley		TRAC	
	Ramp Identification		286 ©	
	Calibration Screw Position or Calibration Disc Quantity		3	
	Spring Color		Green/Blue	
	Spring Length	± 1.5 mm (± 0.060 in)	147.4 (5.80)	
	Clutch Engagement	± 200 RPM	4100	
Driven Pulley Spring Preload		± 0.7 kg (± 1.5 lb)	7.0 (15.4)	
Cam Angle		degree	47° – 50°	
Pulley Distance Z		(+ 0, -1) mm (+ 0, -1/32) in	16.5 (21/32)	
Offset	X	± 0.4 mm ($\pm 1/64$ in)	35.0 (1-3/8)	
	Y – X	MIN. – MAX. mm (in)	1.0 – 2.0 (0.039 – 0.079)	
Drive Belt Part Number (P/N)			415 0603 00	
Drive Belt Width (new) ①		mm (in)	35.0 (1-3/8)	
Drive Belt Adjustment	Deflection	± 5 mm ($\pm 13/64$ in)	32 (1-1/4)	
	Force ②	kg (lbf)	11.3 (25)	
Track	Width	cm (in)	38.1 (15.0)	
	Length	cm (in)	345.5 (136)	
	Adjustment	Deflection	mm (in)	35 – 40 (1-3/8 – 1-3/4)
		Force ③	kg (lbf)	7.3 (16)
Suspension Type	Track		SC10 HP	
	Ski		DSA	
	Length	cm (in)	291 (114.6)	
	Width	cm (in)	118.2 (46.5)	
	Height	cm (in)	108 (42.5)	
	Ski Stance	cm (in)	104.2 (41)	
	Mass (dry)	kg (lb)	261 (574)	
	Ground Contact Area	cm ² (in ²)	7549 (1170)	
	Ground Contact Pressure	kPa (PSI)	3.39 (.492)	
	Frame Material		Aluminum	
	Bottom Pan Material		Impact Copolymer	
Hood Material		RRIM Polyurethane		
	Battery	V (A•h)	N.A.	
	Headlight	W	H4 60/55	
	Taillight and Stoplight	W	8/27	
	Tachometer and Speedometer Bulb	W	2 x 3	
	Fuel and Temperature Gauge Bulb	W	3/3	
	Fuse	Starter Solenoid	A	N.A.
		Tachometer	A	N.A.
	Fuel Tank	L (U.S. gal)	42 (11.1)	
	Chaincase/Gearbox	mL (U.S. oz)	250 (8.5)	
	Cooling System ④	L (U.S. oz)	5.1 (172)	
	Injection Oil Reservoir	L (U.S. oz)	4.1 (139)	

ENGINE LEGEND

BTDC: Before Top Dead Center
CDI: Capacitor Discharge Ignition
CTR: Center
K: Kilo (× 1000)
MAG: Magneto Side
N.A.: Not Applicable
PTO: Power Take Off Side
R: Rectangular
ST: Semi-trapez

- ① The maximum power engine speed is applicable on the vehicle. It may be different under certain circumstances and **BOMBARDIER INC.** reserves the right to modify it without obligation.
- ② Crankshaft end-play is not adjustable on these models. Specification is given for verification purposes only.
- ③ Rotary valve to crankcase clearance: 0.27 – 0.48 mm (.011 – .019 in).
- ④ At 6000 RPM (engine cold) with headlamp turned on.
- ⑤ All resistance measurements must be performed with parts at room temperature (approx. 20°C (68°F)). Temperature greatly affects resistance measurements.
- ⑥ Force applied midway between pulleys to obtain specified tension deflection.
- ⑦ Drive pulley retaining screw: torque to 90 to 100 N•m (66 to 74 lbf•ft), install drive belt, accelerate the vehicle at low speed (maximum 30 km / h (20 MPH)) and apply the brake; repeat 5 times. Recheck the torque of 90 to 100 N•m (66 to 74 lbf•ft).

VEHICLE LEGEND

DSA: Direct Shock Action
RRIM: Reinforced Reaction Injection Molding
TRAC: Total Range Adjustable Clutch
N.A.: Not Applicable

- ① Minimum allowable width may not be less than 2.0 mm (.080 in) of new drive belt.
- ② Force applied midway between pulleys to obtain specified tension deflection.
- ③ Force or downward pull applied to track to obtain specified tension deflection.
- ④ Coolant mixture: 60% antifreeze/40% water.
- ⑤ Lever with roller pin P/N 417 0043 03 (hollow).
- ⑥ Lever with roller pin P/N 417 0043 04 (solid).

WIRING DIAGRAM

MODEL	WIRING DIAGRAM PAGE	HEADLIGHT (watt)	TAILLIGHT (watt)	ELECTRICAL SYSTEM OUTPUT (watt)
Formula III/III LT Mach 1/Z/Z LT	Annex 1	60/55 hal.	8/27	220

hal. = halogen

CHART CODES

Wiring Color Code

The first color of a wire is the main color, second color is the stripe.

Example: YL/BK is a YELLOW wire with a BLACK stripe.

COLOR CODE	
BK — BLACK	GN — GREEN
WH — WHITE	GY — GREY
RD — RED	VI — VIOLET
BL — BLUE	OR — ORANGE
YL — YELLOW	BR — BROWN

ANNEX

Following table shows wire colors related to electrical circuits.

WIRE COLORS	ELECTRICAL CIRCUIT	ADDITIONAL INFORMATION
BLACK/YELLOW	ENGINE SHUT OFF – Key switch – Tether cord switch – Emergency switch	Must be grounded to stop engine.
BLACK (small)	Ground for shut off	
BLACK (Big)	Ground for starter (–)	
YELLOW YELLOW/BLACK	12 volts (A.C.)	If shorted, magneto stops producing electricity.
RED	12 volts (D.C.) (+) For starter motor	
RED/GREEN	12 volts (D.C.) (+) For starter solenoid	
RED/BLUE	12 volts (D.C.) (+) Rectifier output	
GREY	12 volts (A.C.) High beam	Current returns by YELLOW/BLACK wire connected to headlamp.
VIOLET/GREY	12 volts (A.C.) Low beam	
WHITE	12 volts (A.C.) Brake light	Current returns by YELLOW/BLACK wire connected to taillight.
WHITE/RED	12 volts (A.C.) Low oil level	Current returns by YELLOW/BLACK wire connected to oil level sensor.
BLUE	12 volts (A.C.) Fuel level indicator	Current returns by YELLOW wire connected to fuel level sensor.
ORANGE	12 volts (A.C.) Heated grips (max.)	Current returns by YELLOW/BLACK wire connected to heating elements.
ORANGE/VIOLET	12 volts (A.C.) Heated grips (min.)	
BROWN	12 volts (A.C.) Heated throttle lever (max.)	
BROWN/YELLOW	12 volts (A.C.) Heated throttle lever (min.)	
GREEN	12 volts (A.C.) Temperature gauge	Current returns by YELLOW wire connected to sensor.
VIOLET	12 volts (A.C.) Engine overheating light.	

WIRING DIAGRAM

MODEL	WIRING DIAGRAM PAGE	HEADLIGHT (watt)	TAILLIGHT (watt)	ELECTRICAL SYSTEM OUTPUT (watt)
Formula III/III LT Mach 1/Z/Z LT	Annex 1	60/55 hal.	8/27	220

hal. = halogen

CHART CODES

Wiring Color Code

The first color of a wire is the main color, second color is the stripe.

Example: YL/BK is a YELLOW wire with a BLACK stripe.

COLOR CODE	
BK — BLACK	GN — GREEN
WH — WHITE	GY — GREY
RD — RED	VI — VIOLET
BL — BLUE	OR — ORANGE
YL — YELLOW	BR — BROWN

ANNEX

Following table shows wire colors related to electrical circuits.

WIRE COLORS	ELECTRICAL CIRCUIT	ADDITIONAL INFORMATION
BLACK/YELLOW	ENGINE SHUT OFF – Key switch – Tether cord switch – Emergency switch	Must be grounded to stop engine.
BLACK (small)	Ground for shut off	
BLACK (Big)	Ground for starter (–)	
YELLOW YELLOW/BLACK	12 volts (A.C.)	If shorted, magneto stops producing electricity.
RED	12 volts (D.C.) (+) For starter motor	
RED/GREEN	12 volts (D.C.) (+) For starter solenoid	
RED/BLUE	12 volts (D.C.) (+) Rectifier output	
GREY	12 volts (A.C.) High beam	Current returns by YELLOW/BLACK wire connected to headlamp.
VIOLET/GREY	12 volts (A.C.) Low beam	
WHITE	12 volts (A.C.) Brake light	Current returns by YELLOW/BLACK wire connected to taillight.
WHITE/RED	12 volts (A.C.) Low oil level	Current returns by YELLOW/BLACK wire connected to oil level sensor.
BLUE	12 volts (A.C.) Fuel level indicator	Current returns by YELLOW wire connected to fuel level sensor.
ORANGE	12 volts (A.C.) Heated grips (max.)	Current returns by YELLOW/BLACK wire connected to heating elements.
ORANGE/VIOLET	12 volts (A.C.) Heated grips (min.)	
BROWN	12 volts (A.C.) Heated throttle lever (max.)	
BROWN/YELLOW	12 volts (A.C.) Heated throttle lever (min.)	
GREEN	12 volts (A.C.) Temperature gauge	Current returns by YELLOW wire connected to sensor.
VIOLET	12 volts (A.C.) Engine overheating light.	

ANNEX 1

**FORMULA III/III LT
MACH 1/Z/Z LT**

MACH 1 '97
MACH Z
MACH Z LT
FORMULA III
FORMULA III LT

TEMPERATURE
SENSOR

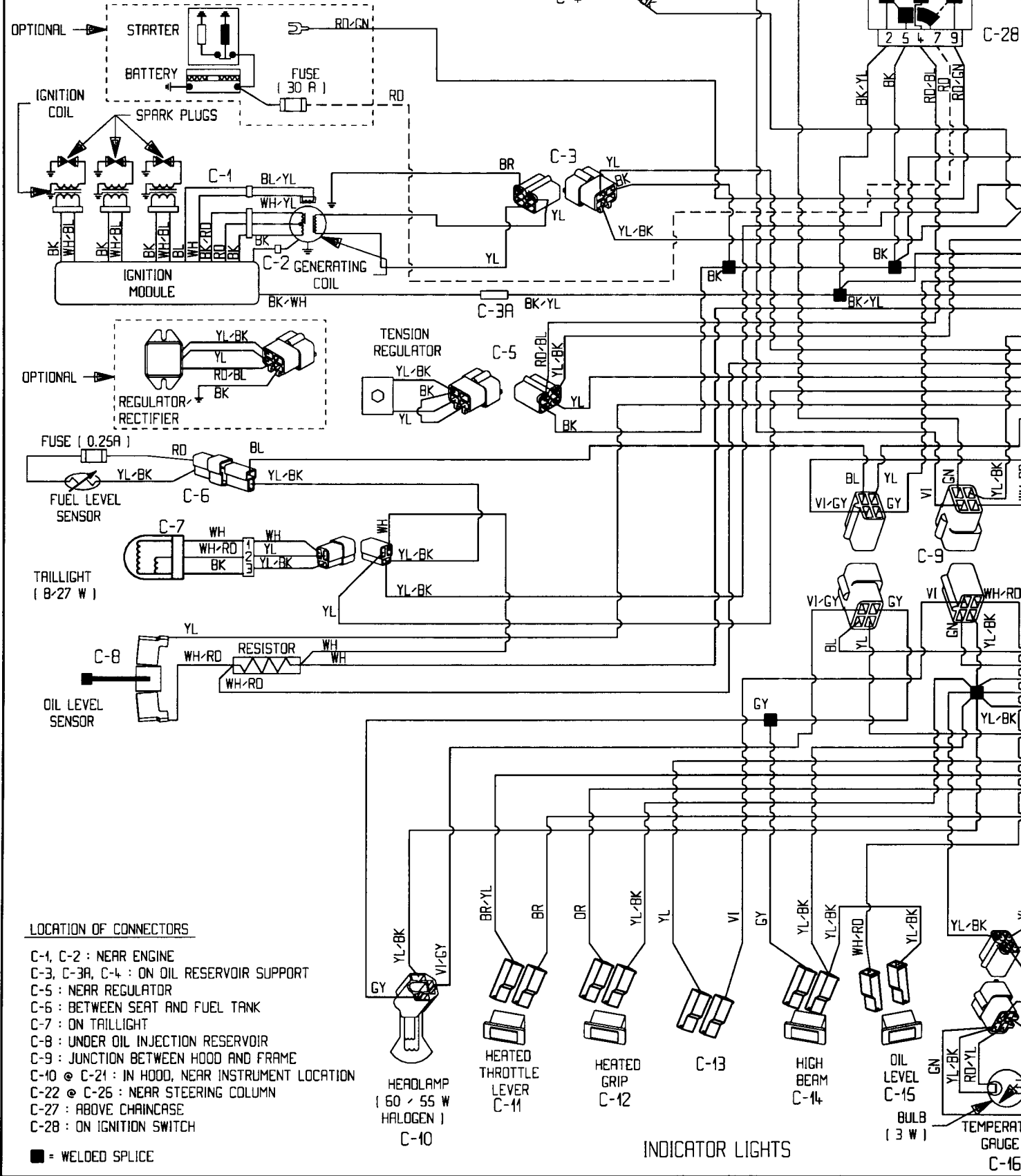

LOCATION OF CONNECTORS

- C-1, C-2 : NEAR ENGINE
- C-3, C-3A, C-4 : ON OIL RESERVOIR SUPPORT
- C-5 : NEAR REGULATOR
- C-6 : BETWEEN SEAT AND FUEL TANK
- C-7 : ON TAILLIGHT
- C-8 : UNDER OIL INJECTION RESERVOIR
- C-9 : JUNCTION BETWEEN HOOD AND FRAME
- C-10 @ C-21 : IN HOOD, NEAR INSTRUMENT LOCATION
- C-22 @ C-26 : NEAR STEERING COLUMN
- C-27 : ABOVE CHAINCASE
- C-28 : ON IGNITION SWITCH

■ = WELDED SPLICE

HEADLAMP
(60 / 55 W
HALOGEN)
C-10

HEATED
THROTTLE
LEVER
C-11

HEATED
GRIP
C-12

C-13

HIGH
BEAM
C-14

OIL
LEVEL
C-15

BULB
(3 W)

TEMPERATURE
GAUGE
C-16

INDICATOR LIGHTS

WARNING :

ENSURE ALL TERMINALS ARE PROPERLY CRIMPED ON THE WIRES AND ALL CONNECTOR HOUSINGS ARE PROPERLY FASTENED.

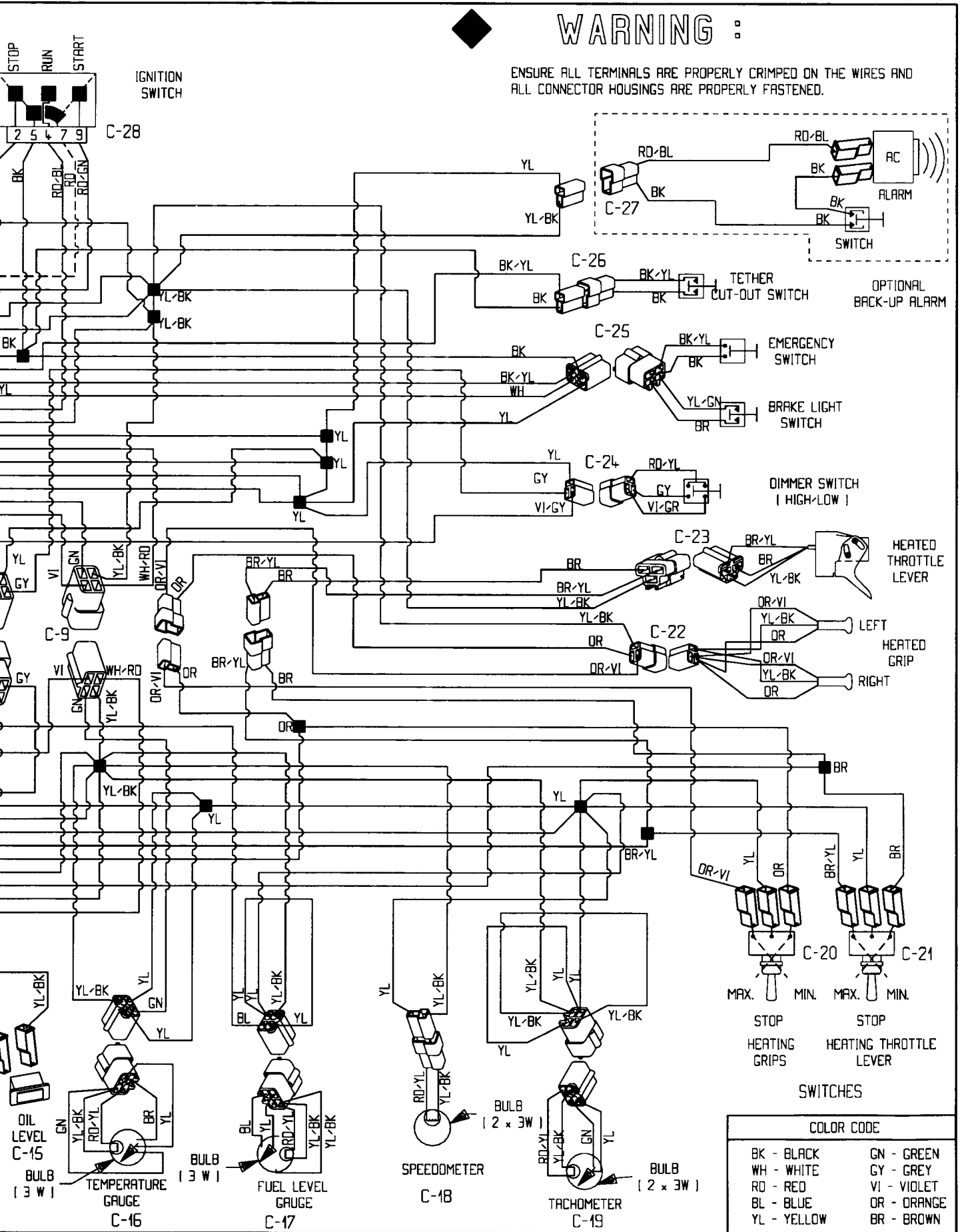

COLOR CODE	
BK - BLACK	GN - GREEN
WH - WHITE	GY - GREY
RD - RED	VI - VIOLET
BL - BLUE	OR - ORANGE
YL - YELLOW	BR - BROWN

® * TRADEMARKS OF BOMBARDIER INC.
ALL RIGHTS RESERVED © BOMBARDIER INC. 1996
LITHO'D IN CANADA

VERSION FRANÇAISE ÉGALEMENT DISPONIBLE

