



◆ WARNING

For safety reasons, this kit must be installed by an authorized Bombardier snowmobile dealer. Should removal of a locking device be required when undergoing disassembly/assembly, always replace with a new one. This instruction sheet should be given to the purchaser. This kit is designed for specific applicable models only. It is not recommended for vehicles other than those for which it was sold.

NOTE: Installation time is approximately 1.0 hour.

PARTS TO BE INSTALLED

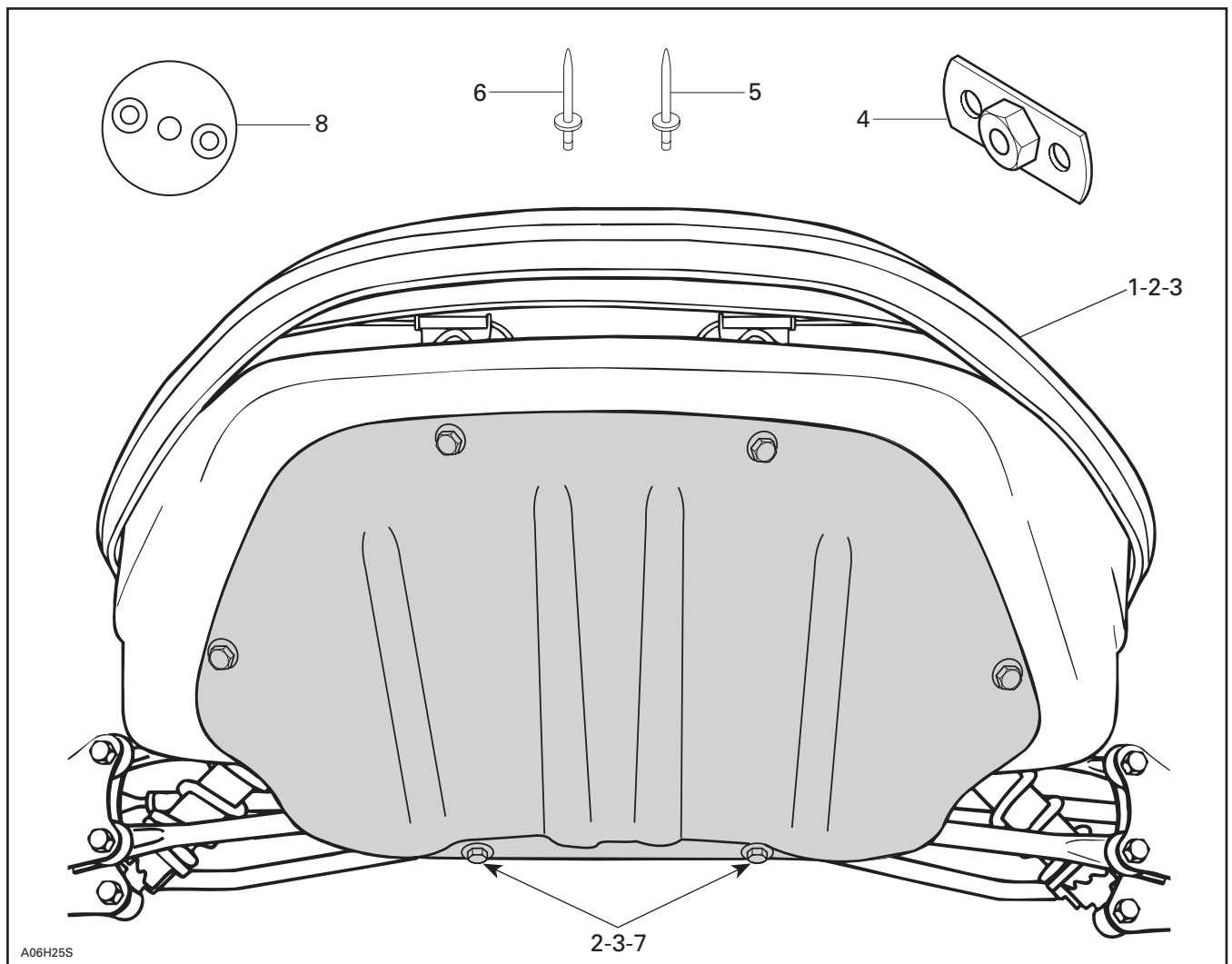

- | | |
|-----------------------|--------------------------------|
| 1. Bolt M6 x 25 (6) | 5. Rivet (4) |
| 2. Lock Washer M6 (6) | 6. Rivet Black (8) |
| 3. Washer M6 (6) | 7. Bolt M6 x 35 (2) (F-Series) |
| 4. Welded Plate (6) | 8. Spacer (2) |

INSTRUCTIONS

F-Series

Remove tuned pipe(s).

Push bottom pan away from front reinforcement, then insert a screwdriver handle between them.

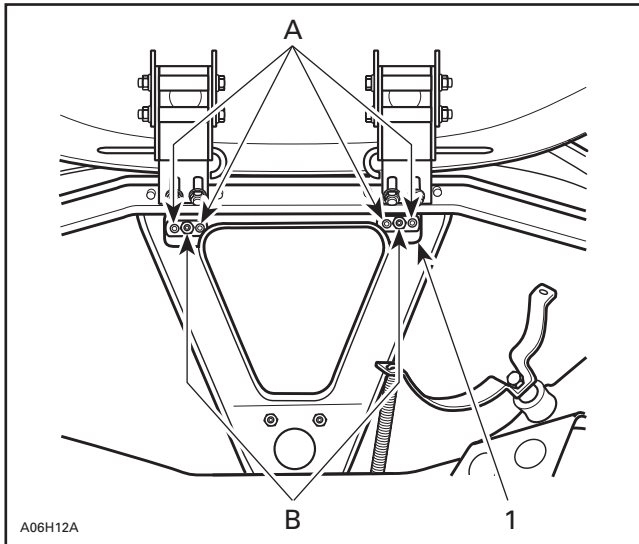

- 1. Template
- A. 4.8 mm (3/16 in) holes
- B. 8 mm (5/16 in) holes

For models that the holes are not already drilled, position template (see page 5 of this instruction sheet) on front reinforcement as illustrated. With a center punch, mark center of small holes (4) then drill 4.8 mm (3/16 in).

Remove screwdriver from behind front reinforcement. Drill 8 mm (5/16 in) center hole through reinforcement and bottom pan (both sides).

Install spacer **no. 8** between front reinforcement and bottom pan. Install 2 welded plates **no. 4** on top of reinforcement then secure with rivets **no. 5**.

Safely lift and hold front of vehicle to work under. Temporarily install skid plate using M6 x 35 bolts **no. 7**, M6 lock washers **no. 2** and flat washers **no. 3** (hand tight).

Center skid plate with bottom pan and drill all other 8 mm (5/16 in) holes.

Remove skid plate.

Using a welded plate **no. 4** as a jig, drill all (8) 4.8 mm (3/16 in) holes if necessary.

Secure welded plates with black rivets **no. 6** (from outside).

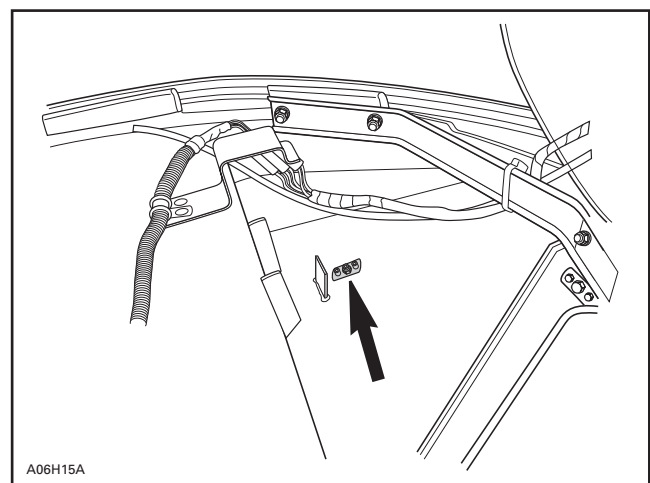
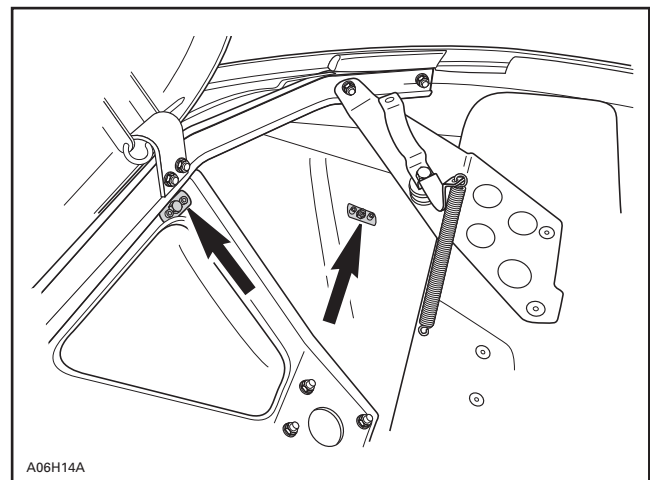
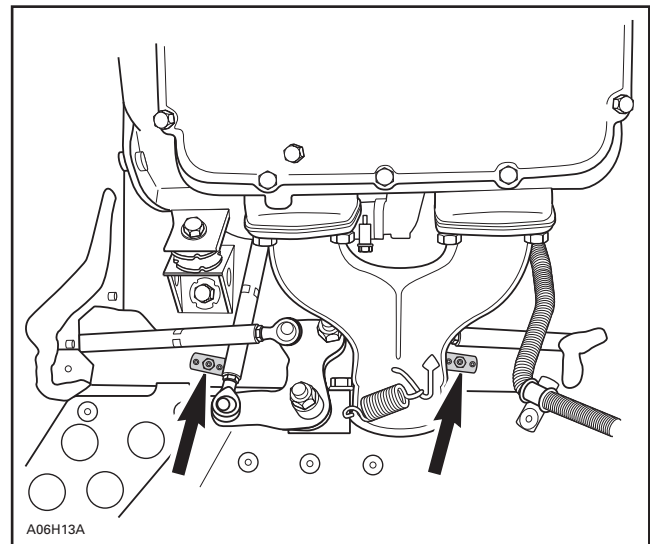

Install skid plate and secure with M6 x 25 bolts **no. 1**, M6 lock washers **no. 2** and flat washers **no. 3**.

Reinstall tuned pipe(s).

INSTRUCTIONS

S-Series

Remove tuned pipe(s).

Safely lift and hold front of vehicle to work under.

From beneath the front of the chassis drill two 8 mm (5/16 in) holes, see illustration.

Remaining under the chassis, drill four 5 mm (3/16 in) holes as shown in the illustration.

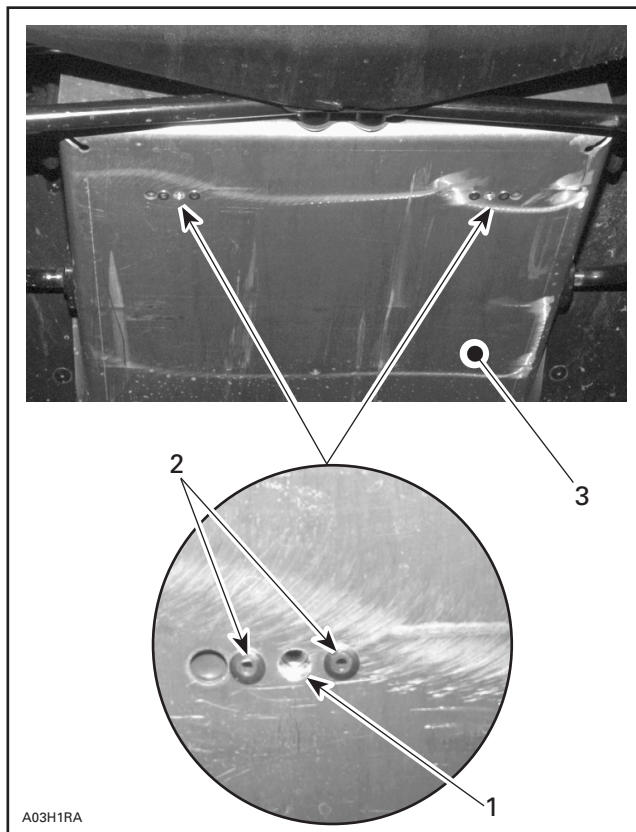

1. Drill two 8 mm (5/16 in) holes
2. Drill four 5 mm (3/16 in) holes
3. Lower chassis

Install two welded plates **no. 4** using pop rivets **no. 5**. Nut on welded plate must be facing upwards.

Temporarily install skid plate, depending on color, using two bolts **no. 1**, two lock washers **no. 2**, and two flat washers **no. 3**, then hand tighten.

Center the skid plate with the front bumper mount.

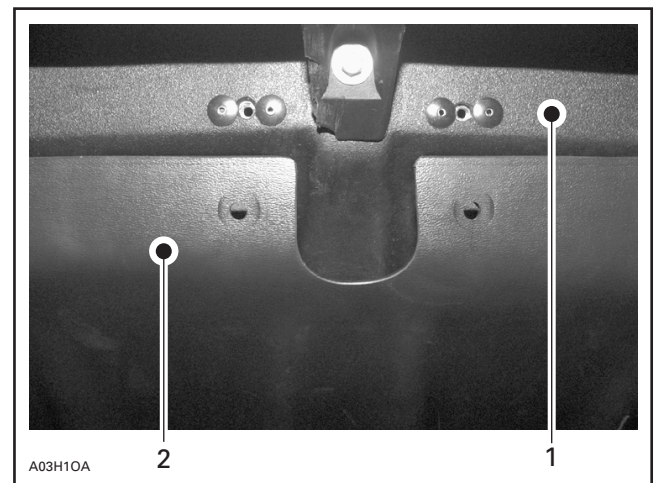

1. Front bumper mount
2. Skid plate

Push on the new skid plate from beneath to assure a tight fit, then using a punch, mark the four holes on the bottom pan.

Loosen the bolts that were previously installed and lower the skid plate.

Drill four 8 mm (5/16 in) holes in the bottom pan.

NOTE: For the following, use one of the bolts **no. 1** and one of the welded plates **no. 4** from this kit as a template.

From inside the engine compartment, insert the bolt through the previously drilled hole in the bottom pan and position the welded plate **no. 4** on the outer side. Position the welded plate so it is horizontal then hand tighten.

Drill two 5 mm (3/16 in) holes.

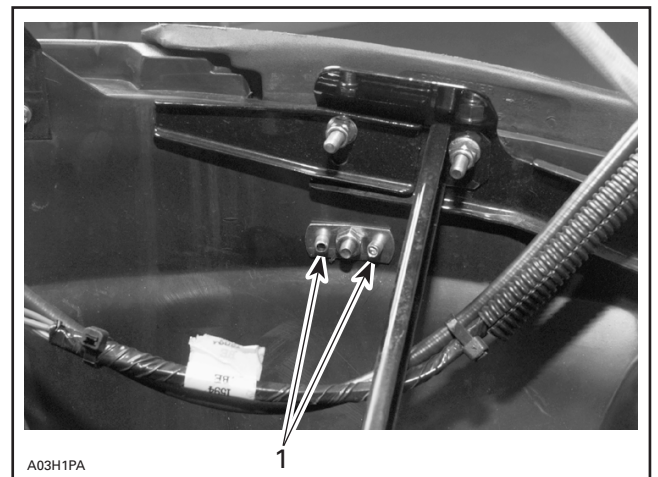

1. Pop rivets **no. 6**

Loosen the bolt and remove the plate.

Repeat this procedure 3 more times.

Install the welded plates **no. 4** from the inside of the engine compartment with the nuts on the plates facing inward.

Secure welded plates using black pop rivets **no. 6**.

Reposition the new skid plate by aligning the holes.

Install bolts **no. 1**, lock washers **no. 2** and flat washers **no. 3**.

Tighten all the bolts so that the new skid plate fits snug.

Reinstall tuned pipe(s).

USE THIS DRILLING TEMPLATE TO
PROPERLY DRILL THE HOLES OF
THE FRONT REINFORCEMENT

F-SERIES

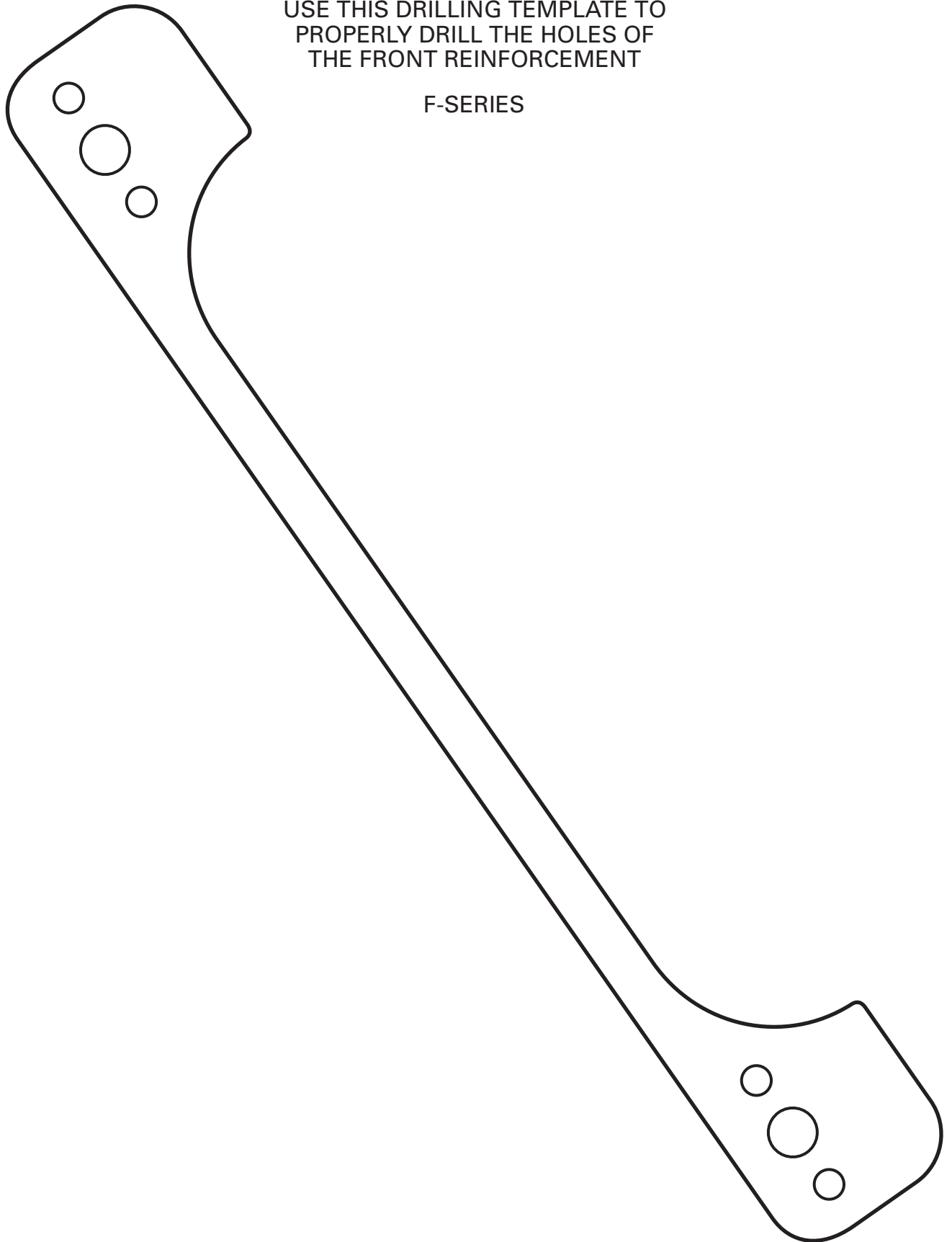

A06H16T

860 5010 00

1.	222 0625 65	Bolt M6 x 25 (6)	Boulon M6 x 25 (6)
2.	224 7611 10	Lock Washer M6 (6)	Rondelle-frein M6 (6)
3.	224 0612 01	Washer M6 (6)	Rondelle M6 (6)
4.	517 2698 00	Welded Plate (6)	Plaque soudée (6)
5.	390 4023 00	Rivet (4)	Rivet (4)
6.	390 4096 00	Rivet Black (8)	Rivet noir (8)
7.	222 0635 65	Bolt M6 x 35 (2) (F-Series)	Boulon M6 x 35 (2) (série F)
8.	517 2698 03	Spacer (2)	Entretoise (2)

F-SERIES		
SKID PLATE DESCRIPTION	P/N KIT (INCLUDING HARDWARE)	P/N SKID PLATE ONLY
BLACK	861 7472 00	572 0727 00
YELLOW	861 7486 00	572 0744 00
RED	861 7536 00	572 0829 00
PURPLE	861 7588 00	572 0900 00
PINK	861 7584 00	572 0901 00

SÉRIE F		
PLAQUE PROTECTRICE DESCRIPTION	N/P NÉCESSAIRE (BOULONNERIE COMPRISE)	N/P PLAQUE PROTECTRICE SEULEMENT
NOIR	861 7472 00	572 0727 00
JAUNE	861 7486 00	572 0744 00
ROUGE	861 7536 00	572 0829 00
VIOLET	861 7588 00	572 0900 00
ROSE	861 7584 00	572 0901 00

S-SERIES		
SKID PLATE DESCRIPTION	P/N KIT (INCLUDING HARDWARE)	P/N SKID PLATE ONLY
BLACK	861 7497 00	572 0785 00
YELLOW	861 7498 00	572 0785 01
RED	861 7534 00	572 0785 02
PINK	861 7589 00	572 0785 03
PURPLE	861 7590 00	572 0785 04

SÉRIE S		
PLAQUE PROTECTRICE DESCRIPTION	N/P NÉCESSAIRE (BOULONNERIE COMPRISE)	N/P PLAQUE PROTECTRICE SEULEMENT
NOIR	861 7497 00	572 0785 00
JAUNE	861 7498 00	572 0785 01
ROUGE	861 7534 00	572 0785 02
ROSE	861 7589 00	572 0785 03
VIOLET	861 7590 00	572 0785 04