



◆ WARNING

For safety reasons, this kit must be installed by an authorized Bombardier Ski-Doo snowmobile dealer. Should removal of a locking device be required when undergoing disassembly/assembly, always replace with a new one. This instruction sheet should be given to the purchaser after modification. This kit is designed for specific applicable models only. It is not recommended for snowmobiles other than those for which it was sold.

NOTE: Installation time is approximately 2.5 hours.

PARTS TO BE INSTALLED

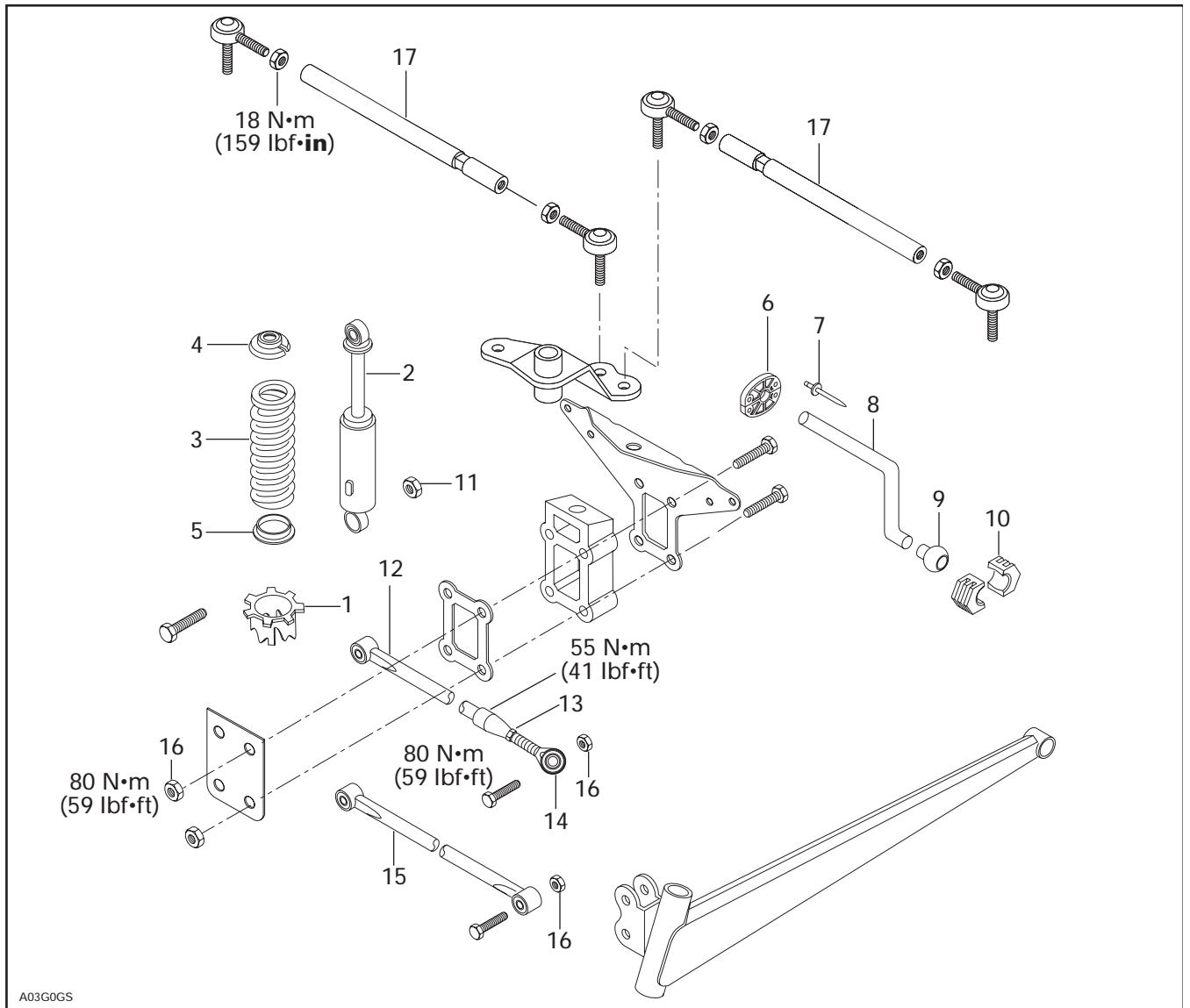

1. Cam (2)
2. Front Shock (2)
3. Spring (2)
4. Spring Stopper (2)
5. Spring Guide (2)
6. Half Bushing (4)
7. Pop Rivets (8)
8. Stabilizer Bar
9. Ball Joint (2)

10. Sliding Block (4)
11. Elastic Nut M10 (4)
12. Upper Arm Assy (2)
13. Jam Nut M14 (2)
14. Ball Joint RH (2)
15. Arm Assy (2)
16. Elastic Nut M 12 (4)
17. Tie Rod (2)

VEHICLE PREPARATION

All Models

Lift the front of the vehicle and support it with a stand.

Remove tuned pipe(s).

Remove the tie-rod by unscrewing it from the ball joints on both sides.

Remove shock absorber assembly.

Remove nuts and bolts from upper and lower control arms which are attached to the swing arms.

Keep bolts and discard nuts.

Unscrew nuts holding upper and lower arms to link plate. Discard nuts.

Models Equipped with the 500 Engine

Remove the plastic caps from the sides of the bottom pan.

Models Equipped with the 583 or the 670 Engine

Remove pop rivets from half bushings on the stabilizer bar.

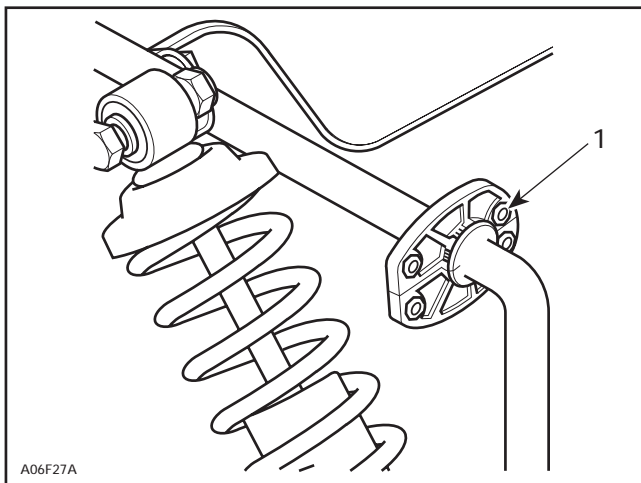

1. Pop rivets (4)

Spread the swing arms apart to free the stabilizer bar.

Remove half bushings from their location then remove the stabilizer bar.

INSTALLATION

All Models

To facilitate installation, proceed with installing one side at a time.

Install the ball joint **no. 14** with jam nut **no. 13** on upper arm assembly **no. 12**.

Remove the upper bolt and arm, replace with new one and secure using new M12 elastic nuts **no. 16**.

Make sure that the ball joint is toward the outside of the machine.

Remove existing lower arm assy and install the new lower arm **no. 15** using M12 elastic nuts **no. 16** (inner side only, do not tighten yet).

Position arms with the angle toward the front as illustrated.

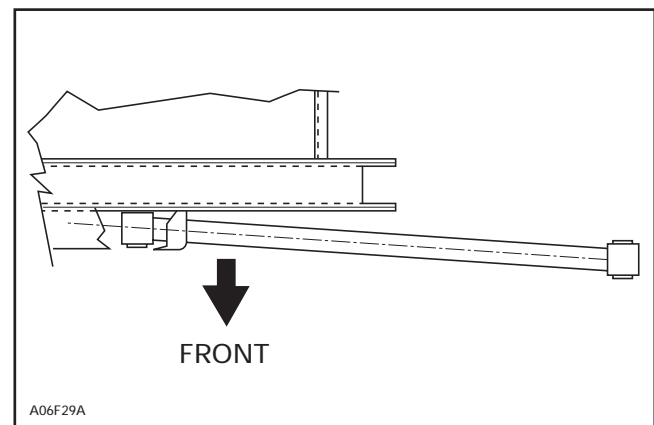

Install new stabilizer bar **no. 8**.

Install half bushing **no. 6** using pop rivets **no. 7**.

Install ball joint **no. 9** in the sliding blocks **no. 10**.

NOTE: Install both sliding blocks at the same time.

Install sliding block into swing arm and apply low temperature grease (P/N 413 7061 00). Refer to the following illustration.

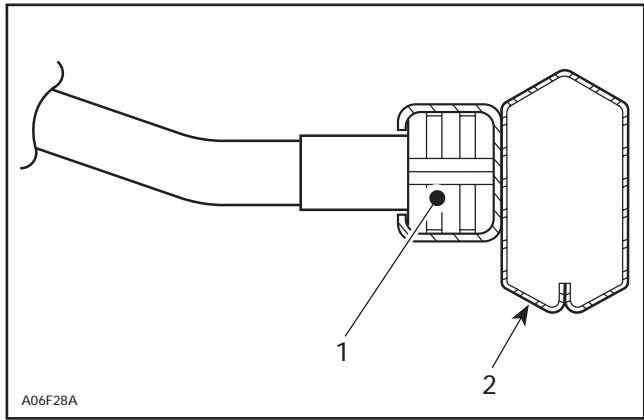

- 1. Sliding block
- 2. Swing arm

Secure upper and lower control arms to swing arm with bolts. Secure with new elastic nuts no. 16. Tighten inner and outer bolts.

Shock Absorber Assembling

For shock assembly, use shock spring remover tool (P/N 529 0271 00)

Install cam no. 1, spring guide no. 5 and spring no. 3 on shock absorber no. 2.

Mount shock in spring remover tool and match spring with spring compressor.

Close and lock the bar. Adjust the handle horizontal position by changing the position of the clevis pin.

Push down on handle until it locks in order to compress the spring.

Install spring stopper no. 4 then carefully release handle.

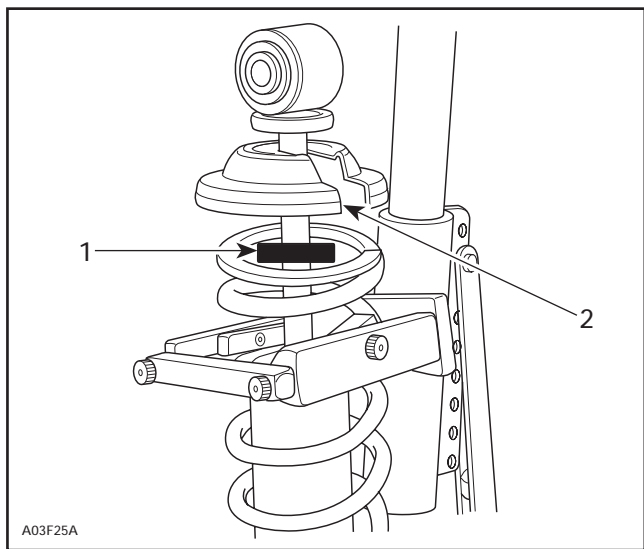

- 1. Rubber bumper
- 2. Spring stopper

Install shock absorber assembly using new elastic nuts no. 11 on top and on bottom.

Install tie-rod no. 17.

Reinstall tuned pipe(s).

ADJUSTMENTS

After assembly, perform a ski alignment and a ski leg camber adjustment.

Refer to the *Ski-Doo Shop Manual* for proper adjustment procedures.

860 5004 00

1.	503 1690 00	Cam (2)	Came (2)
2.	415 0494 00	Front Shock (2)	Amortisseur avant (2)
3.	415 0359 00	Spring (2)	Ressort (2)
4.	503 1406 00	Spring Stopper (2)	Butée de ressort (2)
5.	503 1651 00	Spring Guide (2)	Guide de ressort (2)
6.	572 0299 00	Half Bushing (4)	Demi-douille (4)
7.	390 4023 00	Pop Rivets (8)	Rivet (8)
8.	506 1318 00	Stabilizer Bar	Barre stabilisatrice
9.	503 1422 00	Ball Joint (2)	Rotule (2)
10.	572 0698 00	Sliding Block (4)	Bloc coulissant (4)
11.	228 5010 45	Elastic Nut M10 (4)	Écrou d'arrêt élastique M10 (4)
12.	580 6498 00	Upper Arm Assy (2)	Bras de suspension ajustable (complet) (2)
13.	228 3710 42	Jam Nut M14 (2)	Contre-écrou M14 (2)
14.	415 0425 00	Ball Joint RH (2)	Joint à rotule droit (2)
15.	580 6497 00	Arm Assy (2)	Bras de suspension (complet) (2)
16.	228 5210 45	Elastic Nut M12 (4)	Écrou d'arrêt élastique M12 (4)
17.	506 1360 00	Tie Rod (2)	Barre d'accouplement (2)