



◆ WARNING

For safety reasons, this kit must be installed by an authorized Bombardier snowmobile dealer. Should removal of a locking device be required when undergoing disassembly/assembly, always replace with a new one. This instruction sheet should be given to the purchaser. This kit is designed for specific applicable models only. It is not recommended for vehicles other than those for which it was sold.

○ NOTE : Installation time is approximately 2.5 hours.

PARTS TO BE INSTALLED

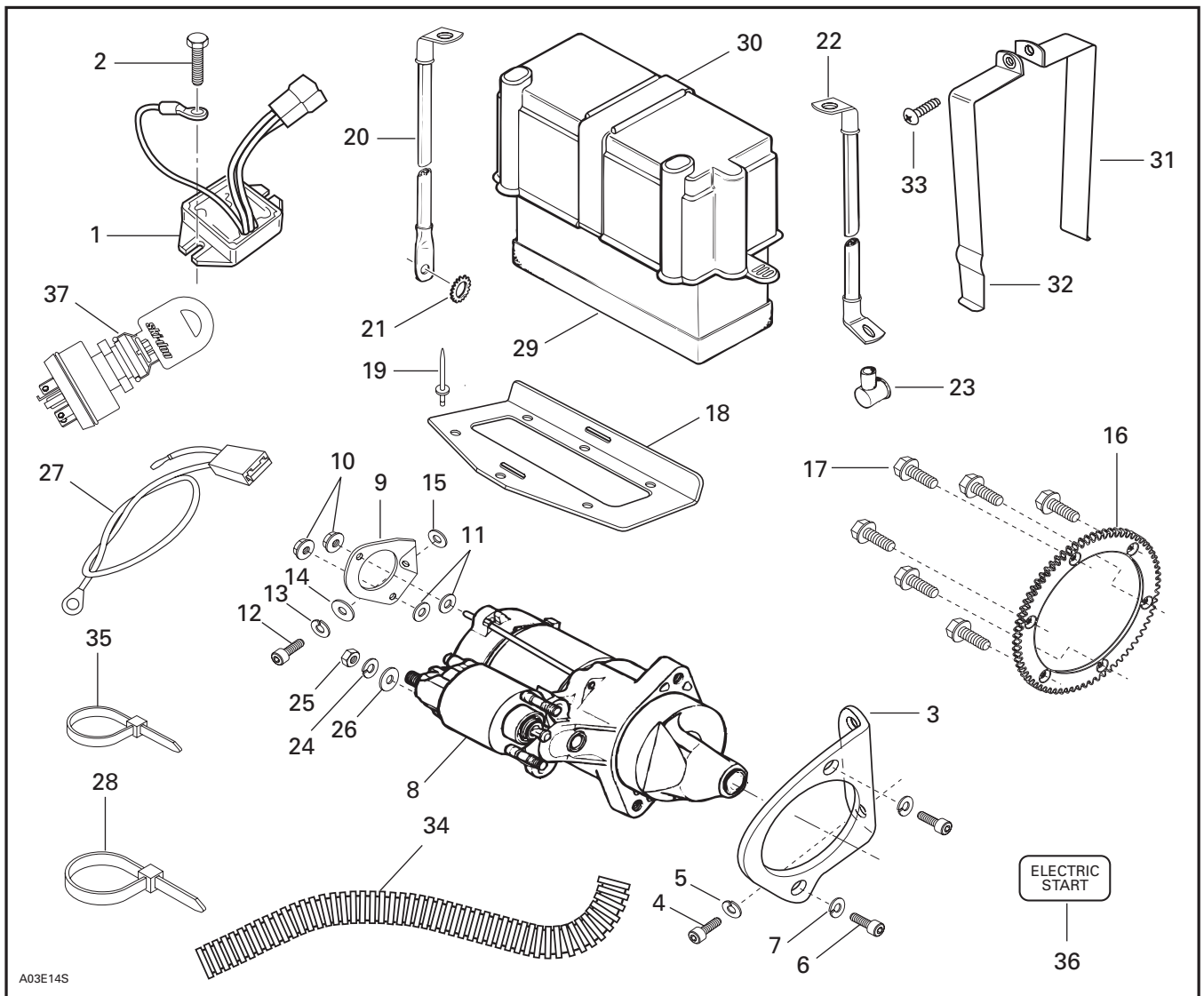

1. Regulator/Rectifier
2. Self-Tapping Screw M6 X 16 (2)
3. Starter Support PTO
4. Socket Screw M8 X 20 (2)
5. Lock Washer (2)
6. Socket Screw M8 X 25 (2)
7. Lock Washer (2)
8. Starter
9. Starter Support MAG
10. Flanged Elastic Nut M5 (2)
11. Washer (2)
12. Socket screw M8 X 20
13. Lock Washer
14. Washer
15. Hardened Washer (2)
16. Ring Gear
17. Self-Tapping Screw M8 X 16 (6)
18. Battery Seat
19. Rivet (6)
20. Battery Ground Cable (BLACK)
21. Star Washer
22. Battery Positive Cable (RED)
23. Protector Cap
24. Lock Washer
25. Nut M8
26. Washer
27. Fuse Holder
28. Locking Tie (8)
29. Battery
30. Battery Cover
31. Welded Steel Strip
32. Steel Strip
33. Machine Screw M5 X 20
34. Protector (2)
35. Locking Tie
36. Decal
37. Ignition Switch

VEHICLE PREPARATION

Battery

 **NOTE :** Refer to the *Ski-Doo Shop Manual* for proper battery removal/installation procedure.

Battery must be charged prior to installing this electric starter kit.

WARNING

Never charge or boost battery while connected or installed in vehicle.

Vehicle

Close fuel shut off valve, if equipped.

Remove exhaust system, belt guard and drive belt.

Unfasten spark plug cables from fan housing. Unplug spark plug caps.

Unplug electronic box harness underneath carburetors by inserting a screwdriver in the connector tab and pull tab as illustrated.

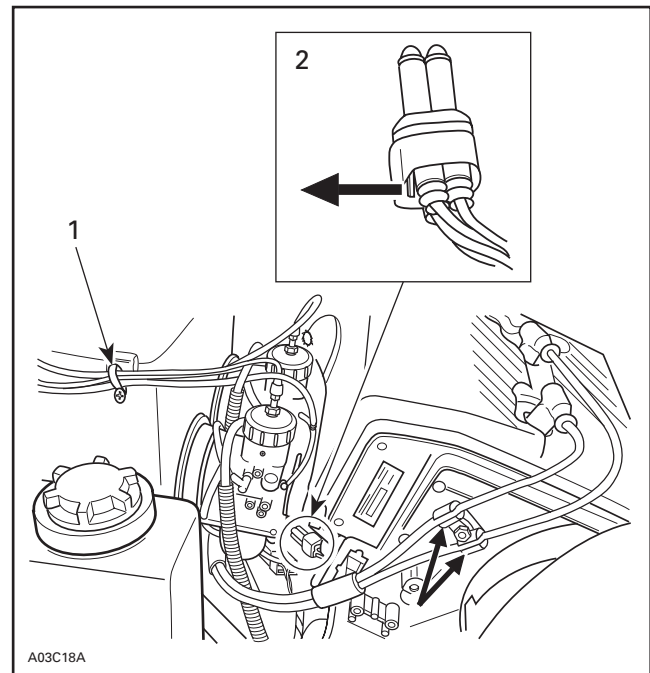

1. Plastic clip
2. CDI box harness connector

Open the plastic clip that is positioned on the air intake silencer. Insert a flat tip screw driver and turn as illustrated.

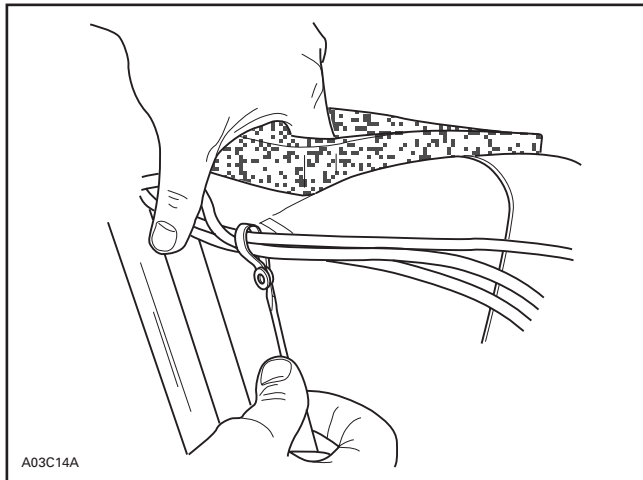

Remove the air intake silencer.

INSTALLATION

Regulator/Rectifier

1. Replace original regulator/rectifier, located along RH side member of frame. Secure the regulator/rectifier **no. 1** on both sides using self tapping screws **no. 2** as well as connecting the ground wire from regulator/rectifier as shown.

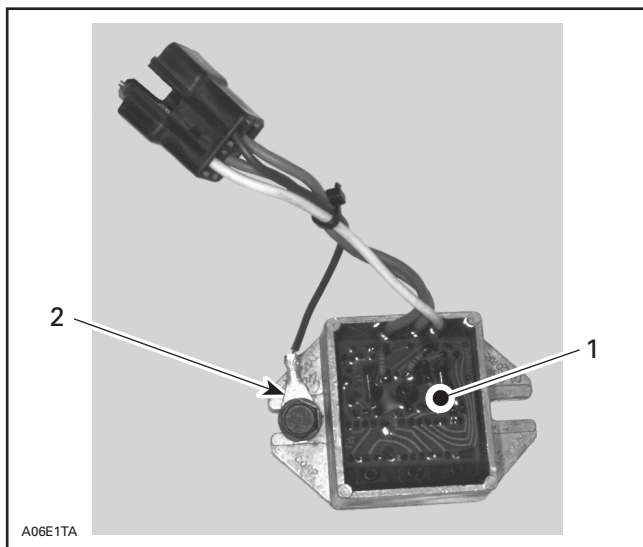

1. Regulator/rectifier
2. Connect ground wire here

2. Apply silicone dielectric grease (P/N 413 7017 00) in the regulator/rectifier 4-connector housing as well as the vehicle harness 4-connector housing and plug them together.

Ring Gear

Remove drive pulley. Refer to *Shop Manual* to perform drive pulley disassembly/assembly procedures and to proceed with pulley alignment.

Secure ring gear **no. 16** on inner half using 6 self tapping screws **no. 17**. Apply Loctite 271 (red) on screw threads.

▼ CAUTION

Loctite 271 (red) must be applied to properly assemble the ring gear.

Torque screws to 27 N•m (20 lbf•ft) in a criss-cross sequence.

Do not reinstall drive pulley at this time.

Ignition Switch

Cut locking tie and unplug switch connector housing from ignition switch. Insert the shortest wire of the fuse holder **no. 27** inside switch connector housing. Insert connector in position number 7 on the switch-connector housing. Reposition connectors respecting the vehicle connector code as illustrated.

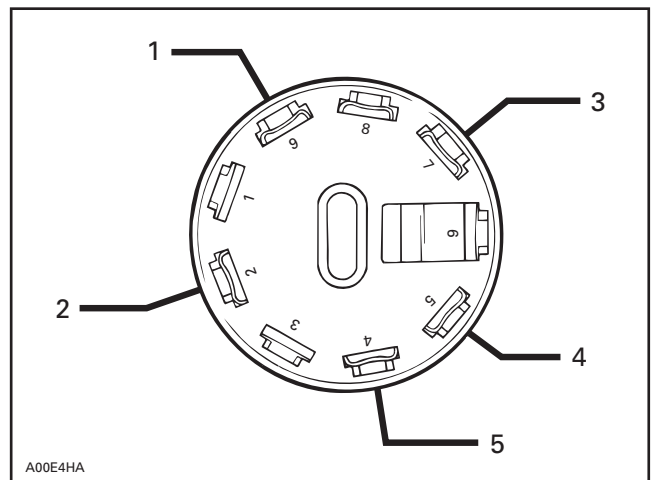

1. RED/GREEN wire to solenoid
2. BLACK/YELLOW
3. RED wire with fuse to battery
4. BLACK
5. RED/BLUE

Replace ignition switch **no. 37**

Replug switch connector housing to ignition switch and secure wires with a locking tie **no. 28** as shown.

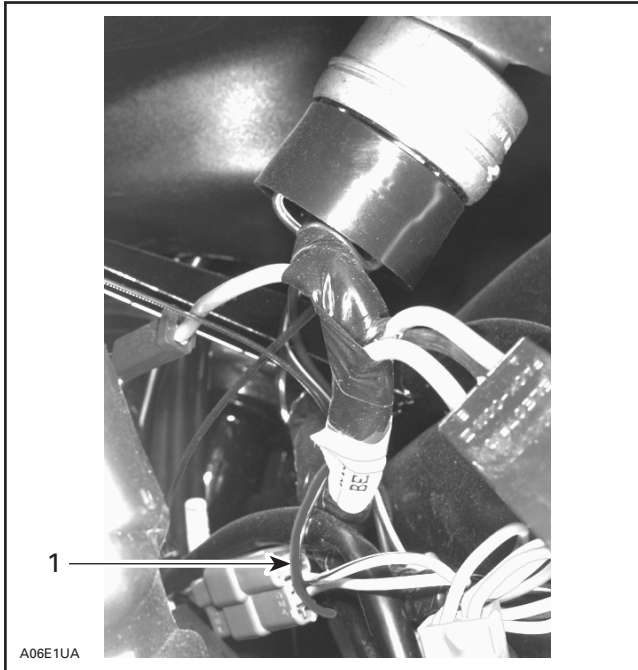

1. Locking tie

Wire/Cable Connections and Routing

Ensure that one connector of the RED battery cable **no. 22** is bent to 90° and the other connector bent to 60°. Bend as necessary.

Starting from battery location, route battery cable along vehicle harness to the starter location.

The 90° bent connector will be connected to the battery.

○ **NOTE** : Route battery cables through free bracket underneath countershaft as illustrated.

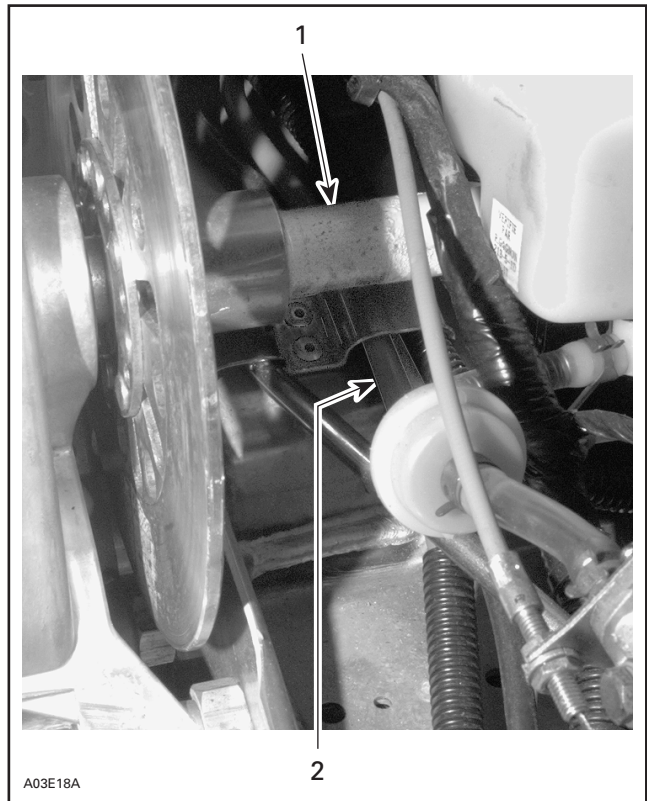

1. Countershaft
2. Battery cables underneath bracket

Install BLACK battery ground cable **no. 20** with star washer **no. 21** to the rewind starter. Secure with the existing rewind starter bolt. Refer to the following illustration for proper cable positioning.

○ **NOTE** : Connect BLACK ground cable in the specified order. Position star washer first then BLACK ground cable and tighten with original screw.

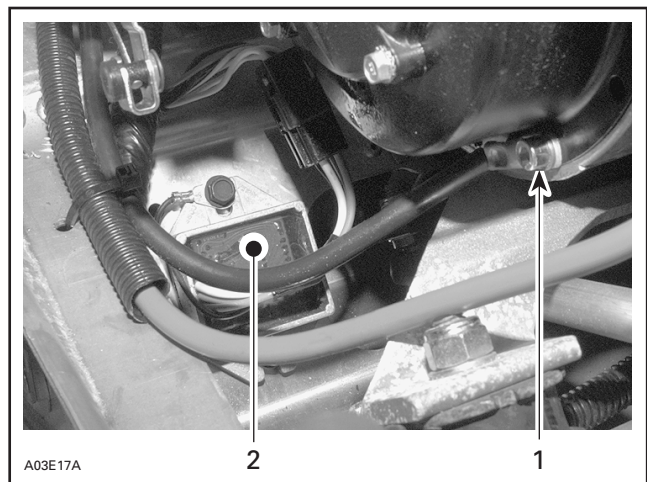

1. Connect BLACK ground cable here
2. Regulator

Electric Starter

▼ CAUTION

Apply Loctite 271 (red) on all fastener threads of starter supports.

Install starter support **no. 3** (PTO side) to engine using socket screws **no. 4** and lock washers **no. 5**. Tighten firmly.

Install electric starter **no. 8** on support. Secure bottom first and then the top using socket screws **no. 6** and lock washers **no. 7**.

Install washers **no. 11** over nuts of starter through bolts (MAG side).

Install starter support **no. 9** (MAG side) to starter and secure with flanged elastic nuts **no. 10**.

If necessary, install hardened washer(s) **no. 15** to fill the gap between the support and the engine. Secure the support to the engine with washer **no. 14**, lock washer **no. 13** and screw **no. 12**.

Install cable protector **no. 34** then slide protector cap **no. 23** onto RED battery cable **no. 22**. Bend the terminal to fit. Install RED cable on starter with washer **no. 26**, lock washer **no. 24** and nut **no. 25**. Cover battery post with protector cap. Install locking tie as shown.

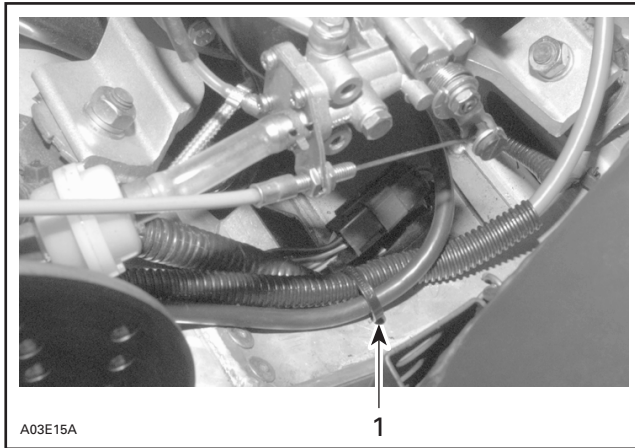

1. Locking tie

Cut the locking tie that is retaining the RED/GREEN wire to the wiring harness beneath engine.

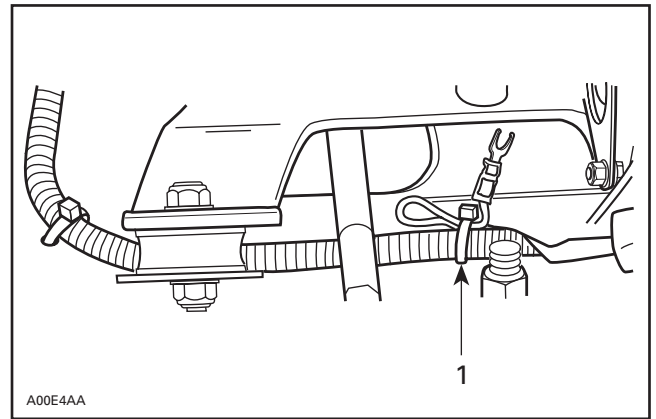

1. Cut locking tie

Connect RED/GREEN wire to the small post on solenoid. Position connector under lock washer.

Secure cables loosely to the rear bracket with a locking tie **no. 28**, as illustrated.

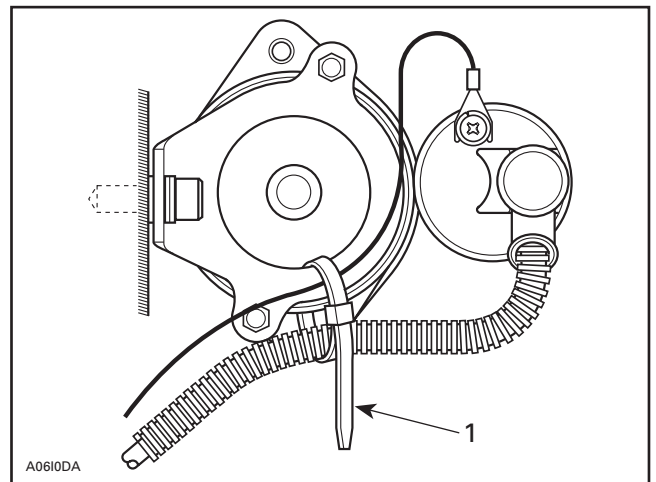

1. Tie loosely

Pull excess amount of cable from underneath engine.

Battery and Rack

▼ CAUTION

Cover carburetor intakes with a clean rag during the following drilling operation.

Drill 6 holes in the chassis with a 5.2 mm (13/64 in) drill bit as shown in the following illustration. Use existing holes in chassis as a guide and push down plastic cap to remove it.

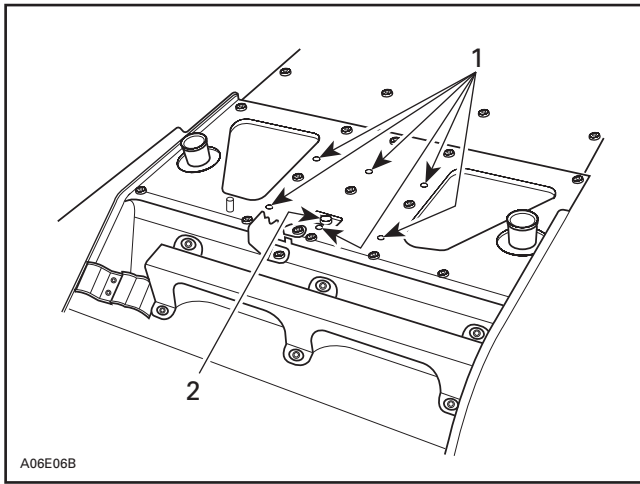

1. Drill 5.2 mm (13/64 in) holes
2. Push down plastic cap

Secure battery seat no. 18 with 6 rivets no. 19.
Install battery no. 29 on seat and connect vent tube to battery and the other end to the hollow rivet on chassis. Cut vent tube to proper length as necessary. Ensure that the tube is not kinked or blocked.

◆ WARNING

Vent tube must be free and open. A kinked or blocked tube will restrict battery ventilation and allow gas accumulation that could cause an explosion.

Connect battery RED positive cable and RED wire with fuse from ignition switch to battery, THEN connect the BLACK ground cable. Secure cables on top of the battery posts.

◆ WARNING

Always connect the battery cables exactly in the specified order. Connect RED positive cable first, then BLACK negative ground cable.

Install battery cover no. 30, strips no. 31 and no. 32 and secure with machine screw no. 33. Route the RED battery cable and the RED wire through the indentation on the front battery strip. Fasten battery cables using a locking tie no. 35, as illustrated.

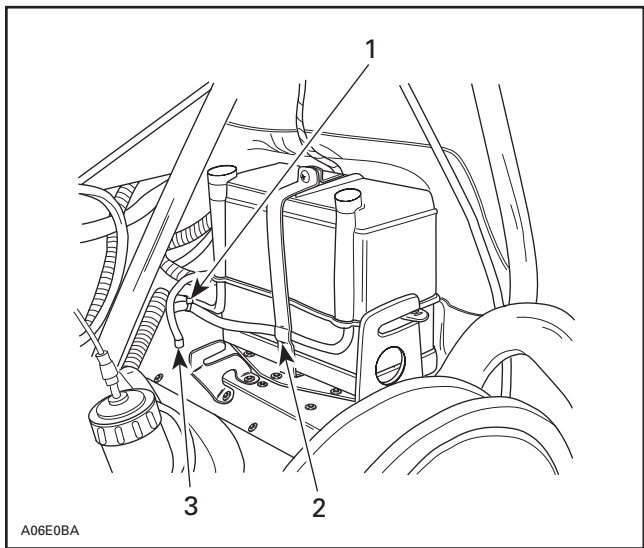

1. Locking tie on battery cables here
2. Indentation on front of battery strip
3. Vent tube on hollow rivet

◆ WARNING

Ensure all terminals are properly crimped on wires/cables and that all connector housings are properly fastened. Keep wires away from any rotating, moving, heating or vibrating parts as well as from sharp edges. Use proper fastening devices as required.

FINALIZING INSTALLATION

○ NOTE : Refer to the *Ski-Doo Shop Manual* for proper reinstallation procedure.

Reinstall drive pulley.

Check pulley alignment.

◆ WARNING

Drive pulley alignment must always be checked whenever pulleys have been removed, replaced or disassembled.

Reinstall remaining removed parts.

Decal

Clean decal region with soapy water or isopropyl alcohol using a soft clean cloth and dry thoroughly.

▼ CAUTION

Do not apply isopropyl alcohol on decal.

Remove backing from decal.

Apply decal no. **36** as shown.

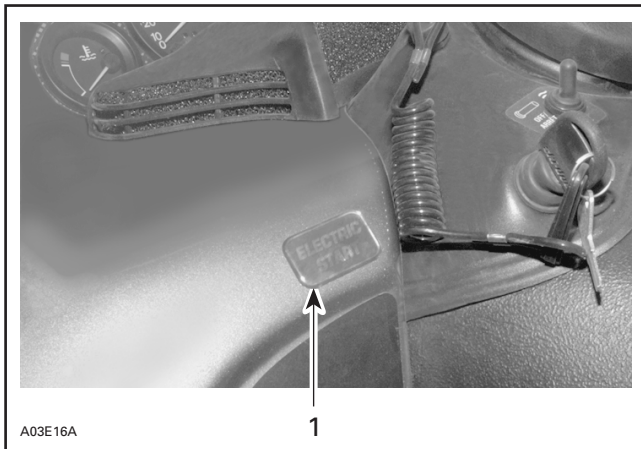

1. Decal

861 7555 00

1.	515 1639 00	Regulator / Rectifier	Régulateur / Redresseur
2.	732 6000 02	Self-Tapping Screw M6 x 16 (2)	Vis autotaraudeuse M6 x 16 (2)
3.	420 9514 17	Starter Support PTO	Support de démarreur côté PDM
4.	222 9820 65	Socket Screw M8 x 20 (2)	Vis à tête creuse M8 x 20 (2)
5.	420 9457 52	Lock Washer M8 (2)	Rondelle-frein M8 (2)
6.	222 9825 65	Socket Screw M8 x 25 (2)	Vis à tête creuse M8 x 25 (2)
7.	224 7811 40	Lock Washer M8 (2)	Rondelle-frein M8 (2)
8.	410 2124 00	Starter	Démarreur
9.	420 9514 27	Starter Support MAG	Support de démarreur côté MAG
10.	228 7510 45	Flanged Elastic Nut M5 (2)	Écrou d'arrêt élastique à épaulement M5 (2)
11.	391 3017 00	Washer (2)	Rondelle (2)
12.	222 9820 65	Socket Screw M8 x 20	Vis à tête creuse M8 x 20
13.	420 9457 52	Lock Washer M8	Rondelle-frein M8
14.	224 0811 71	Washer M8	Rondelle M8
15.	503 0079 00	Hardened Washer (2)	Rondelle trempée (2)
16.	415 0431 00	Ring Gear	Couronne de lancement
17.	732 6012 46	Self-Tapping Screw M8 X 16 (6)	Vis autotaraudeuse M8 X 16 (6)
18.	517 2862 00	Battery Seat	Support de batterie
19.	390 4022 00	Rivet (6)	Rivet (6)
20.	515 1570 00	Battery Ground Cable (BLACK)	Câble de masse de la batterie (NOIR)
21.	394 0019 00	Lock Washer (Star)	Rondelle-frein (étoile)
22.	515 1613 00	Battery Positive Cable (RED)	Câble positif de la batterie (ROUGE)
23.	570 1510 00	Protector Cap	Capuchon de protection
24.	420 9457 52	Lock Washer M8	Rondelle-frein M8
25.	228 0810 45	Nut M8	Écrou M8
26.	224 0811 71	Washer M8	Rondelle M8
27.	515 1573 00	Fuse Holder	Porte-fusible
28.	414 1152 00	Locking tie (8)	Attache (8)
29.	410 3011 00	Battery	Batterie
30.	570 0220 00	Battery Cover	Couvercle de batterie
31.	517 2860 00	Welded Steel Strip	Bande d'acier soudée
32.	517 2861 00	Steel Strip	Bande d'acier
33.	222 0520 65	Hex Screw M5 x 20	Vis à métaux M5 x 20
34.	414 6273 00	Protector (2)	Protecteur (2)
35.	748 0010 01	Locking tie	Attache
36.	418 0013 00	Decal	Autocollant
37.	410 1113 00	Ignition Switch	Interrupteur d'allumage