



### ◆ WARNING

For safety reasons, this kit must be installed by an authorized Bombardier snowmobile dealer. Should removal of a locking device be required when undergoing disassembly/assembly, always replace with a new one. This instruction sheet should be given to the purchaser. This kit is designed for specific applicable models only. It is not recommended for vehicles other than those for which it was sold

NOTE : Installation time is approximately 2.2 hours.

### PARTS TO BE INSTALLED

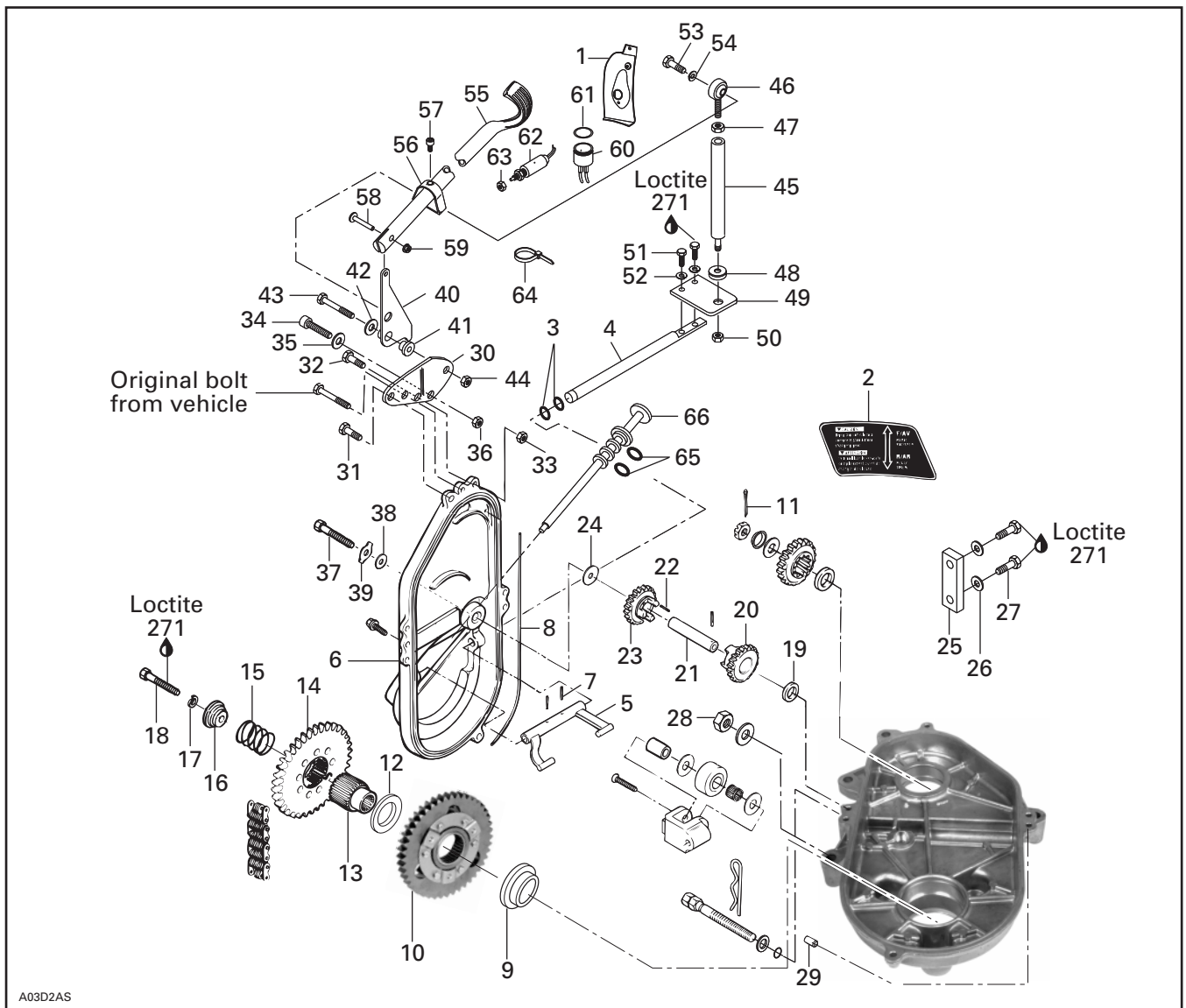

A03D2AS

1. Console
2. Decal
3. O-ring, Viton (2) (Brown)
4. Shaft
5. Fork
6. Chaincase Cover
7. Spring Pin (2)
8. O-ring
9. Retaining Ring
10. Sprocket Assembly, 44 Tooth
11. Cotter Pin
12. Washer
13. Coupling Shaft
14. Sliding Gear
15. Release Spring
16. Cap
17. Lock Washer M10
18. Hex Bolt M10 x 50
19. Ring
20. Drive Sprocket, 19 Tooth
21. Reverse Shaft Assembly
22. Rubber Alignment Rod
23. Reverse Sprocket, 19 Tooth
24. Thrust Washer
25. Chain Slider
26. Flat Washer (2)
27. Hex Bolt M6 x 16 (2)
28. Elastic Nut M10
29. Dowel Pin
30. Pivot Support
31. Taptite Hex Bolt M6 x 16
32. Hex Bolt M6 x 20
33. Elastic Nut M6
34. Socket Screw M6
35. Washer M6
36. Flanged Elastic Nut M6
37. Reverse Shaft Bolt M8 x 90
38. Copper Washer M8
39. Locking Tab
40. Pivot Plate
41. Flanged Bushing
42. Washer M8
43. Hex Bolt M8 x 45
44. Elastic Nut M8
45. Tie-Rod
46. Ball Joint
47. Tie-Rod Jam Nut M6
48. Rubber Washer
49. Tie-Rod Plate
50. Elastic Nut M5
51. Hex Bolt M5 x 14 (2)
52. Lock Washer M5 (2)
53. Hex Bolt M6 x 20
54. Lock Washer M6
55. Handle
56. Switch Stopper
57. Metal Screw
58. Steel Rivet 3/16
59. Push Nut 3/16
60. Backup Alarm
61. Plastic Nut
62. Switch Assembly
63. Nut
64. Locking Tie
65. O-ring (2)
66. Dipstick

## INSTRUCTIONS

▼ **CAUTION**

Do not use a 20-tooth or 24-tooth sprocket with the 44-tooth sprocket.

### CONSOLE PREPARATION

Replace the right side console no. 1.

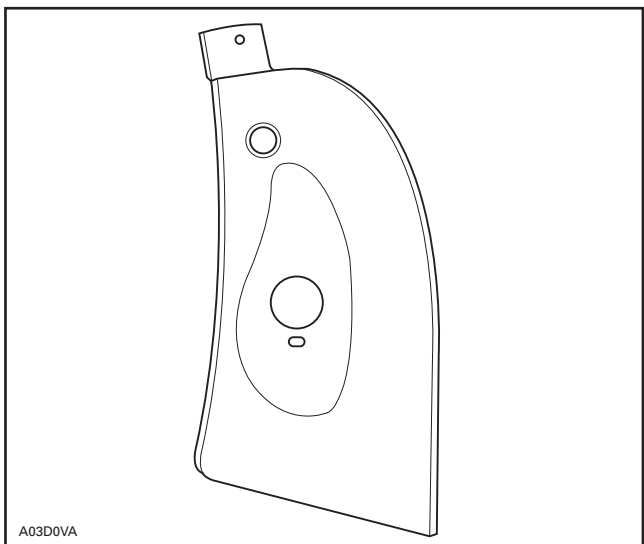

Install decal no. 2 on vehicle hood as per illustration.

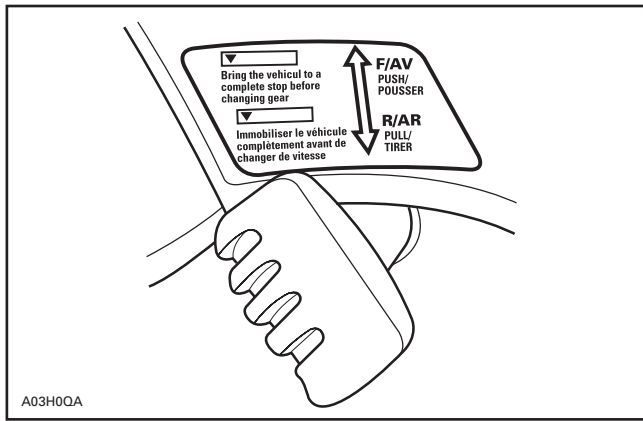

### CHAINCASE PREPARATION

1. Remove tuned pipe and muffler.
2. Remove chain tension.
3. Remove chaincase cover then remove upper and lower sprockets and lower spacer. Discard lower sprocket, spacer, M10 bolt, lock washer, cap and chaincase cover.

### Chaincase Cover

1. Install O-rings **no. 3** on fork shaft **no. 4** and spread grease on it. Install the fork **no. 5** and shaft in the new chaincase cover **no. 6**. Secure with spring pins **no. 7**. Ensure to position flat surface of the shaft lever upwards, as illustrated.
2. Install O-ring **no. 8** in cover.

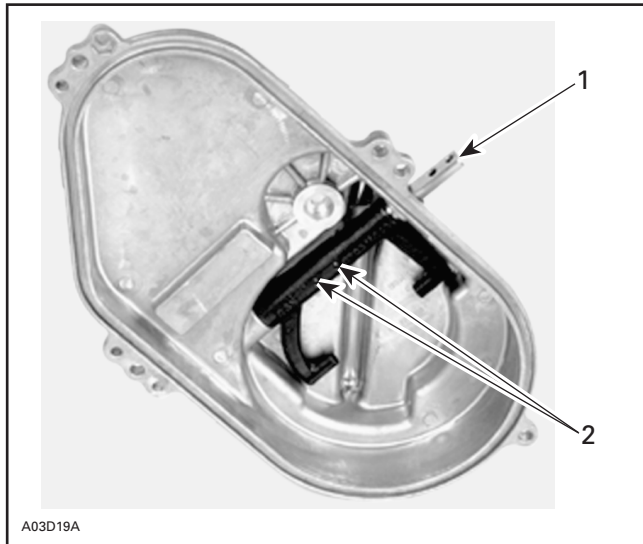

1. Position notch towards the top
2. Align holes

### Chaincase

1. Remove and discard bolts, copper washers close to the chain tensioner adjustment screw.

NOTE : M10 nut may need to be removed to allow access to the Allen bolt.

### Finalizing Chaincase Assembly

1. Install the retaining ring **no. 9** and the lower sprocket ass'y **no. 10** over the drive axle and properly mesh with the chain

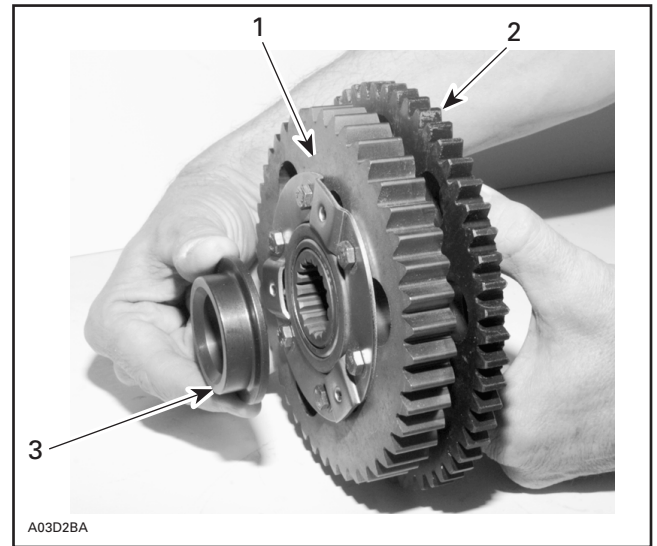

1. 44 tooth gear
2. 56 tooth gear
3. Retaining Ring

2. Install upper sprocket, spacer, Belleville washer and torque the castellated nut to 45 to 75 N•m (33 to 55 lbf•ft). Secure the nut with a new cotter pin **no. 11**.
3. Install washer **no. 12** onto coupling shaft **no. 13** then insert between the sliding sprocket and the lower sprocket ass'y. Install the sliding sprocket **no. 14**, release spring **no. 15**, cap **no. 16**, lock washer **no. 17** and bolt **no. 18**. Apply Loctite 271 (red) on the bolt threads, use sparingly. Torque bolt to 42 to 54 N•m (31 to 40 lbf•ft).

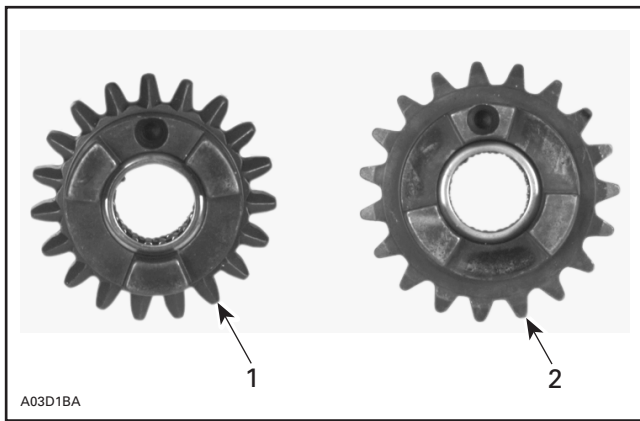

1. Reverse sprocket (hole between dogs)
2. Drive sprocket (hole on dog)

4. Install chain slider **no. 25** and position longitudinal chamfer against chaincase wall. Position flat washers **no. 26** against bolts **no. 27**. Apply Loctite 271 (red) on screw threads, use sparingly.

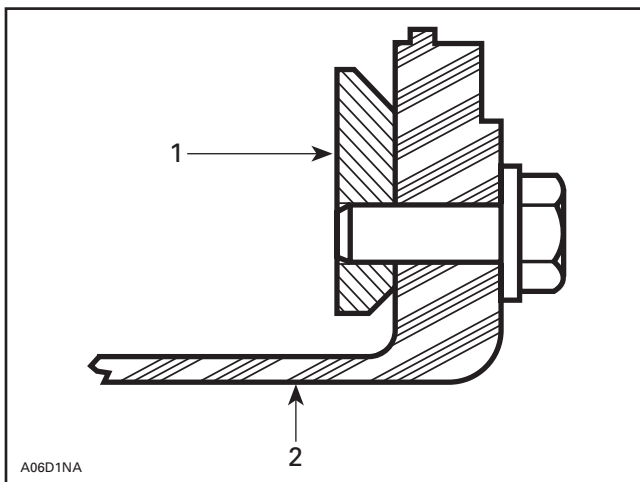

1. Chain slider
2. Chaincase side facing the chassis

5. Install the new elastic nut **no. 28** and torque to 38 to 45 N•m (28 to 33 lbf•ft), if removed.
6. Fully tighten the chain adjusting screw by hand, then back off only far enough for hair pin to engage in the locking hole.
7. Insert dowel pin **no. 29** to chaincase.
8. Join chaincase cover to chaincase by passing fork tabs behind sliding sprocket lip.

**CAUTION**

Chaincase cover must completely lay against chaincase.

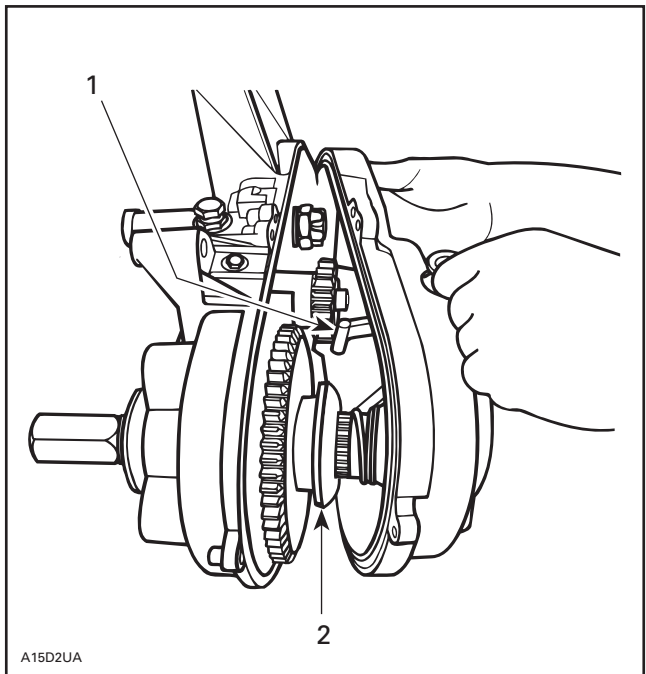

1. Fork tabs
2. Sliding sprocket lip

9. Install pivot support **no. 30** on chaincase with the original bolt. Install self-tapping bolt **no. 31** and bolt **no. 32** with nut **no. 33**. Install socket screw **no. 34** with washer **no. 35** and nut **no. 36** on pivot support.

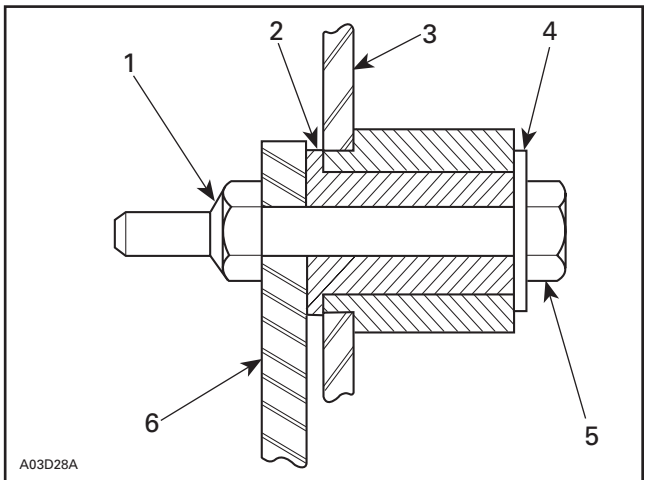

1. Elastic nut
2. Flanged bushing
3. Pivot plate
4. Washer
5. Hex bolt
6. Pivot support

10. Tighten chaincase bolts in a criss-cross sequence beginning with top center. Install reverse shaft bolt **no. 37** with copper washer **no. 38** against chaincase cover and locking tab **no. 39** against bolt head. Position angle end of tab to rear then torque bolt to 13.5 to 17 N•m (120 to 150 lbf•in). Bend locking tab against bolt head.

## SHIFTING LINKAGE ASSEMBLY

1. Install the pivot plate **no. 40** on the pivot support **no. 30** with a flanged bushing **no. 41**, flat washer **no. 42**, bolt **no. 43** and the nut **no. 44**.
2. Install on one end of the tie-rod **no. 45** the ball joint **no. 46**, with jam nut **no. 47** then on the other, install rubber washer **no. 48**, tie-rod plate **no. 49** with its offset towards the rear and secure with elastic nut **no. 50**. Tighten nut.

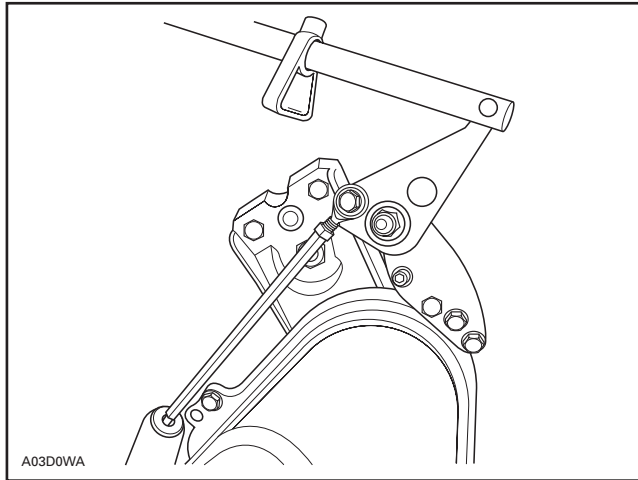

3. Secure the plate on shaft **no. 4** with bolts **no. 51** and lock washers **no. 52**. Apply Loctite 242 (blue), use sparingly.
4. Install ball joint on swivel plate with bolt **no. 53** and lock washer **no. 54**.

### Handle Installation

Insert handle **no. 55** through hole in console. Slide switch stopper **no. 56** over handle then secure with screw **no. 57**. Do not tighten screw yet. Connect handle extremity to swivel plate and secure with steel rivet **no. 58** and push nut **no. 59**.

### Backup Alarm Installation

1. Install backup alarm **no. 60** on bracket, secure using plastic nut **no. 61** as shown in the following illustration.

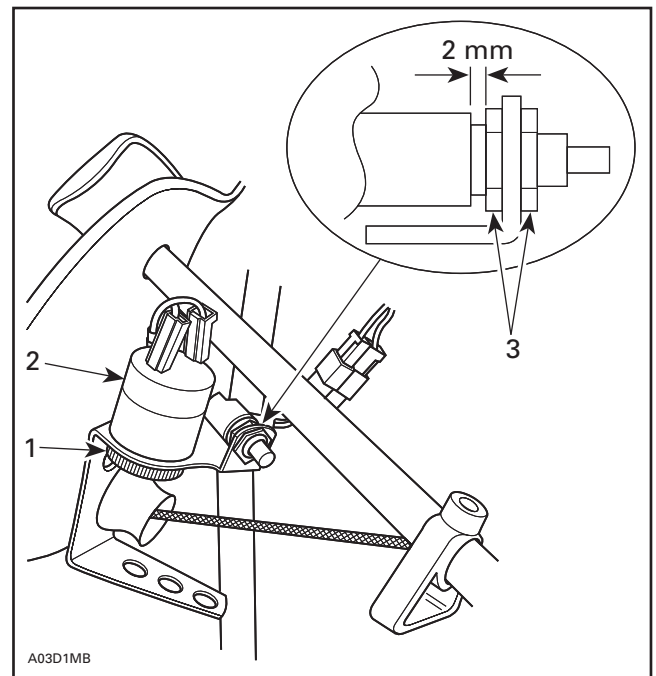

1. Plastic nut
2. Backup alarm
3. One nut on each side of the bracket

2. Install switch assembly **no. 62** and secure using nut **no. 63**, **one on each side**. Connect terminals to the alarm, make sure that RED/BLUE wire is connected to alarm negative post. Connect tab connector housing to vehicle harness. Secure wiring harness with locking tie **no. 64**. Refer to above illustration.

## ADJUSTMENTS

1. Check proper fit of handle in console.
2. Shift into reverse gear.

**NOTE** : If it is impossible to shift into reverse gear, shorten tie-rod and try again. Turn the brake disk to free the gears. If it is impossible, check if the fork engages in the sliding gear or disassemble the cover to inspect components.

3. Completely slacken ball joint lock nut **no. 47** on the gear shift linkage.
4. Using tool (P/N 529 0303 00) to push and hold down tie-rod plate **no. 49** to make sure transmission is in reverse gear. Pull shifter handle in reverse position making sure all slack is removed. Lengthen tie-rod until it contacts the rubber washer then add an additional turn.

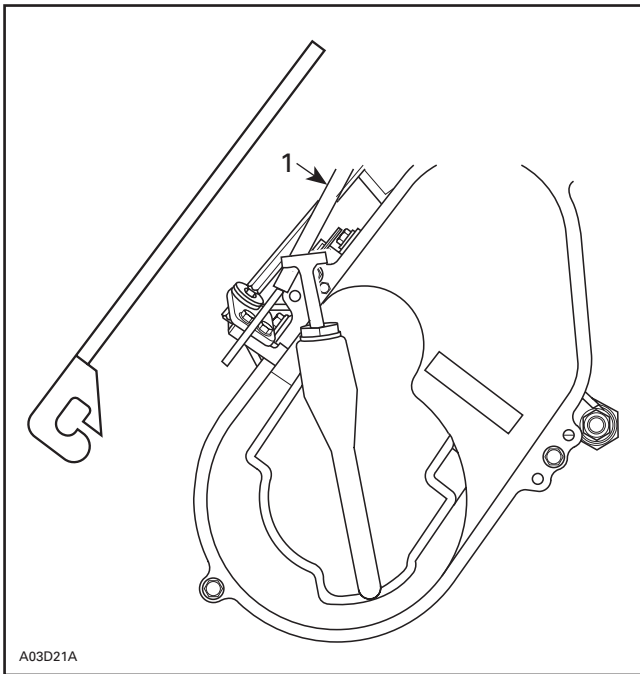

1. Tool

**NOTE :** It is normal to feel a light friction when shifting into gear.

5. Statically test transmission operation in forward and reverse positions.
6. Hold linkage and tighten ball joint jam nut **no. 47**.
7. Adjust backup alarm so that it sounds when transmission is in reverse gear while engine is running.

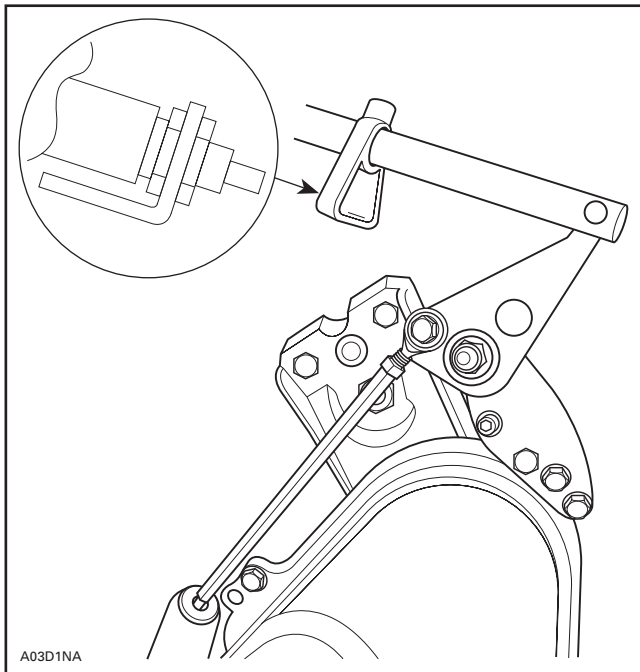

A03D1NA

## FILLING WITH OIL

1. Fill chaincase with chaincase oil (P/N 413 8019 00). Oil capacity is approximately 250 mL (8 oz).
2. Install 2 O-rings **no. 65** on the new dipstick **no. 66**.
3. Check oil level with dipstick, oil level must be between the marks.

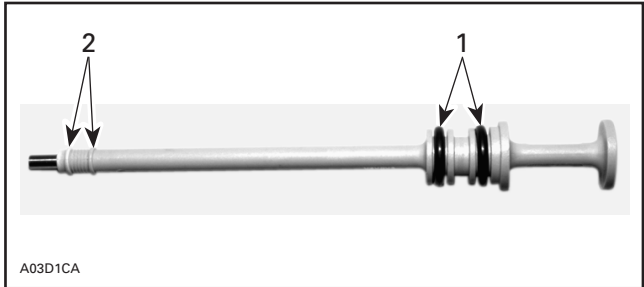

A03D1CA

1. O-rings
2. Oil level marks

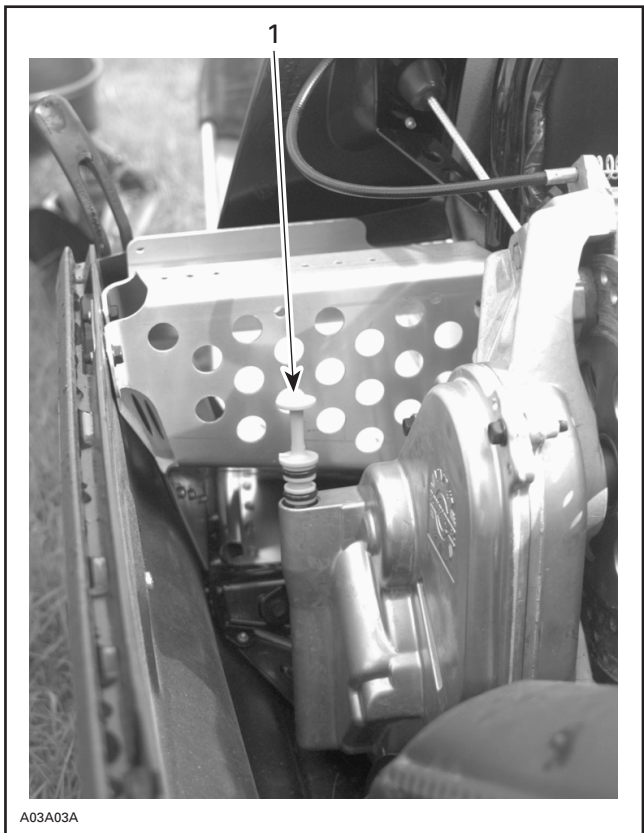

A03A03A

1. Dipstick
4. Reinstall tuned pipe and muffler.
5. Test drive transmission operation.

## 860 4233 00

1.	572 0521 00	Console	Console
2.	414 9016 00	Decal Reverse	Autocollant
3.	414 7732 00	O-ring, Viton (2)	Joint torique en viton (2)
4.	504 1429 00	Shaft	Arbre
5.	504 0758 00	Fork	Fourchette
6.	504 0985 00	Chaincase Cover	Couvercle du carter de chaîne
7.	414 7725 00	Spring Pin (2)	Goupille ressort (2)
8.	414 3623 00	O-ring	Joint torique
9.	504 0763 00	Retaining Ring	Bague de retenue
10.	581 0968 00	Sprocket Assembly, 44 Tooth	Pignon complet, 44 dents
11.	371 8013 00	Cotter Pin	Goupille fendue
12.	504 0943 00	Washer	Rondelle
13.	504 0977 00	Coupling Shaft	Arbre d'accouplement
14.	504 0968 00	Sliding Gear	Pignon coulissant
15.	504 0992 00	Release Spring	Ressort de rappel
16.	504 0991 00	Cap	Capuchon
17.	224 7011 88	Lock Washer M10	Rondelle-frein M10
18.	222 0050 65	Hex Bolt M10 x 50	Boulon M10 x 50
19.	504 0787 00	Ring	Bague
20.	581 0969 00	Drive Sprocket, 19 Tooth	Pignon d'entraînement, 19 dents
21.	580 5906 00	Reverse Shaft Assembly	Arbre de marche arrière (complet)
22.	570 0486 00	Rubber Alignment Rod	Tige d'alignement de caoutchouc
23.	581 1222 00	Reverse Sprocket, 19 Tooth	Pignon de marche arrière, 19 dents
24.	504 0773 00	Thrust Washer	Rondelle de butée
25.	504 0824 00	Chain Slider	Coulisseau de chaîne
26.	732 9000 40	Flat Washer (2)	Rondelle (2)
27.	222 0616 65	Hex Bolt M6 x 16 (2)	Boulon M6 x 16 (2)
28.	228 5010 45	Elastic Nut M10	Écrou d'arrêt élastique M10
29.	732 6200 01	Dowel Pin	Goupille d'assemblage
30.	504 0950 00	Pivot Support	Support de pivot
31.	732 6000 02	Taptite Hex Bolt M6 x 16	Boulon autotaraudeur M6 x 16
32.	222 0620 65	Hex Bolt M6 x 20	Boulon M6 x 20
33.	228 5610 45	Elastic Nut M6	Écrou d'arrêt élastique M6
34.	222 9616 65	Socket Screw M6	Vis à tête creuse M6
35.	224 0611 51	Washer M6	Rondelle M6
36.	228 5610 45	Elastic Nut M6	Écrou à épaulement élastique M6

## 860 4233 00

37.	222 0890 65	Hex Bolt M8 x 90	Boulon M8 x 90
38.	504 0829 00	Copper Washer M8	Rondelle de cuivre M8
39.	504 0877 00	Locking Tab	Patte de verrouillage
40.	504 0949 00	Pivot Plate	Plaque de pivot
41.	414 9276 00	Flanged Bushing	Douille à épaulement
42.	224 0812 01	Washer M8	Rondelle M8
43.	222 0845 65	Hex Bolt M8 x 45	Boulon M8 x 45
44.	228 5810 45	Elastic Nut M8	Écrou d'arrêt élastique M8
45.	504 0947 00	Tie-Rod	Barre d'accouplement
46.	414 7734 00	Ball Joint	Joint à rotule
47.	228 0610 45	Tie-Rod Jam Nut M6	Contre-écrou du joint à rotule M6
48.	570 0457 00	Rubber Washer	Rondelle de caoutchouc
49.	504 0946 02	Tie-Rod Plate	Plaque de barre d'accouplement
50.	228 5510 45	Elastic Nut M5	Écrou d'arrêt élastique M5
51.	222 0514 65	Hex Bolt M5 x14 (2)	Boulon M5 x 14 (2)
52.	224 7510 90	Lock Washer M5 (2)	Rondelle-frein M5 (2)
53.	222 0620 65	Hex Bolt M6 x 20	Boulon M6 x 20
54.	224 7611 10	Lock Washer M6	Rondelle-frein M6
55.	570 0446 00	Handle	Poignée
56.	572 0711 00	Switch Stopper	Butée d'interrupteur
57.	364 9016 00	Metal Screw	Vis à tôle
58.	390 0089 00	Steel Rivet 3/16	Rivet d'acier 3/16
59.	389 8043 00	Push Nut 3/16	Écrou à pression 3/16
60.	414 7921 02	Backup Alarm	Avertisseur de marche arrière
61.	414 8051 01	Plastic Nut	Écrou en plastique
62.	515 1658 00	Switch Assembly	Interrupteur complet
63.	732 6100 75	Nut	Écrou
64.	414 1152 00	Locking Tie(2)	Attache (2)
65.	414 9694 00	O-ring (2)	Joint torique (2)
66.	572 0927 00	Dipstick	Jauge de niveau d'huile